

The Role of HVDC Transmission Systems in the Evolution of the Italian Power System

Original

The Role of HVDC Transmission Systems in the Evolution of the Italian Power System / Ferrara, Claudio; Mosca, Carmelo; Cuccia, Paolo; Urbanelli, Andrea; Zanghì, Antonio; Belmonte, Luca; Chicco, Gianfranco. - In: ENERGIES. - ISSN 1996-1073. - ELETTRONICO. - 19:3(2026). [10.3390/en19030779]

Availability:

This version is available at: 11583/3009067 since: 2026-03-23T19:35:51Z

Publisher:

MDPI

Published

DOI:10.3390/en19030779

Terms of use:

This article is made available under terms and conditions as specified in the corresponding bibliographic description in the repository

Publisher copyright

(Article begins on next page)

Article

The Role of HVDC Transmission Systems in the Evolution of the Italian Power System

Claudio Ferrara ¹, Carmelo Mosca ¹, Paolo Cuccia ¹ , Andrea Urbanelli ¹, Antonio Zanghi ¹, Luca Belmonte ¹ and Gianfranco Chicco ^{2,*} 

¹ Terna S.p.A., Viale Egidio Galbani, 70, 00156 Roma, Italy; claudio.ferrara@terna.it (C.F.); carmelo.mosca@terna.it (C.M.); paolo.cuccia@terna.it (P.C.); andrea.urbanelli@terna.it (A.U.); antonio.zanghi@terna.it (A.Z.); luca.belmonte@terna.it (L.B.)

² Dipartimento Energia “Galileo Ferraris”, Politecnico di Torino, Corso Duca degli Abruzzi 24, 10129 Torino, Italy

* Correspondence: gianfranco.chicco@polito.it

Abstract

This paper explores the potential contributions of modern High-Voltage Direct-Current (HVDC) transmission systems to the Italian National Power System, with a focus on adequacy and security, and providing an overview of their role in system stability. An operational methodology is proposed to assess the impact of planned infrastructure developments, within the context of medium- to long-term forecast scenarios. To this end, starting from a model of the current transmission network, a prospective model of the primary transmission grid for the year 2040 was developed, covering voltage levels of 230 kVAC, 400 kVAC, and 525 kVDC. Load-flow analysis under both N and N-1 conditions was performed, with particular emphasis on the Ionian–Tyrrhenian HVDC backbone “Priolo–Rossano–Latina”.

Keywords: high voltage direct current; planning; scenario; operation; power systems; transmission infrastructure; renewables

1. Introduction

The energy transition, driven by end-use electrification, is significantly increasing operational complexity and requires major upgrades to the transmission infrastructure.

In the Italian context, the challenges posed by the variability of non-dispatchable renewable energy sources are further worsened by the geographical mismatch between the main load centers, located in the northern part of the country (Figure 1), and the areas with the highest potential for photovoltaic and wind power generation, primarily situated in the South and on the major islands (Figure 2).

It is important to note that the current grid was originally designed to support a northern-oriented system, featuring the main load centers, most of the hydro and thermal generation, and strong interconnections with four neighbouring countries. This contrasts with the southern portion of the network, which is characterized by lower load levels and by wind and solar power plants, at present predominantly connected to the 150 kV sub-transmission grid, along with limited thermal generation capacity.



Academic Editors: José Matas and Adrian Ilinca

Received: 10 November 2025

Revised: 23 December 2025

Accepted: 22 January 2026

Published: 2 February 2026

Copyright: © 2026 by the authors.

Licensee MDPI, Basel, Switzerland.

This article is an open access article

distributed under the terms and

conditions of the [Creative Commons](https://creativecommons.org/licenses/by/4.0/)

[Attribution \(CC BY\)](https://creativecommons.org/licenses/by/4.0/) license.

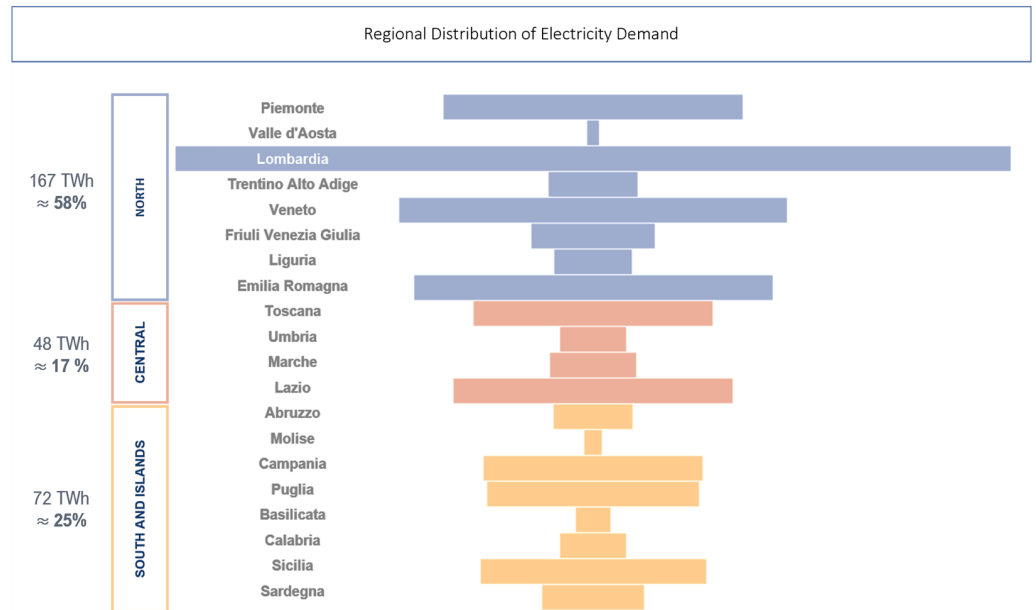

Figure 1. Regional Distribution of Electricity Demand, annual values (2023). The lengths are proportional to the electricity demand. Source: Terna, Statistical Publications.

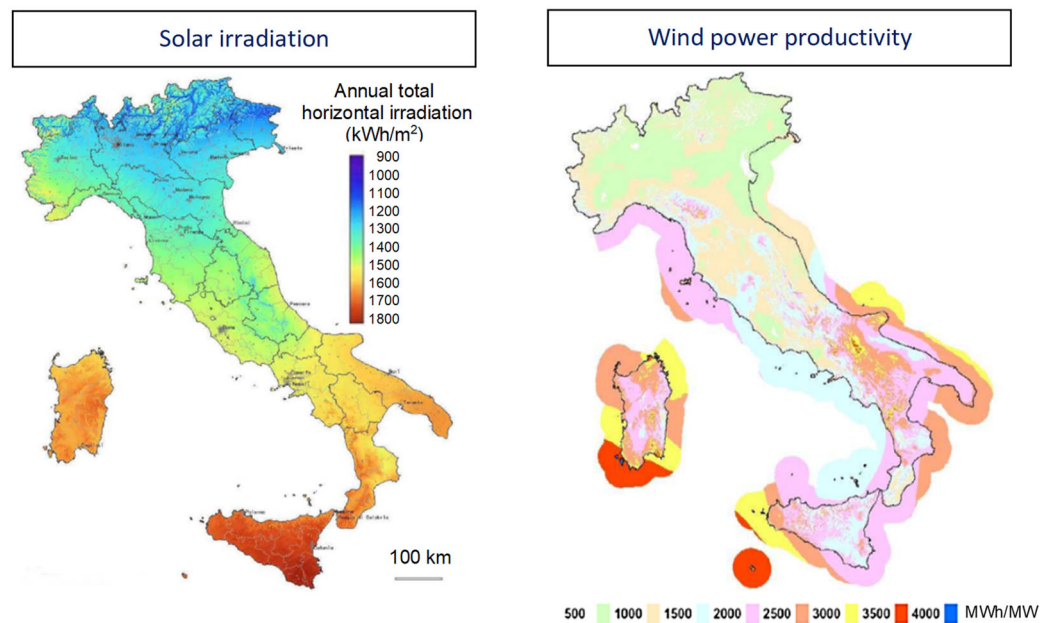

Figure 2. Potential for photovoltaic and wind power production.

An analysis of connection requests to the transmission network indicates a marked geographical divergence in system evolution. On the one hand, a rapid increase in renewable capacity—mainly solar photovoltaic (PV) and wind—is expected in Southern Italy. On the other hand, a significant concentration of new electricity demand is emerging in Northern regions, driven in particular by energy-intensive loads such as data centers. As of November 2025, connection requests for data centers amount to approximately 57 GW out of a total of 64 GW nationwide, largely concentrated in Northern Italy, while renewable energy source (RES) connection requests reach about 335 GW overall, with approximately 262 GW located in Southern Italy and the Islands [1].

The progressive intensification of this North–South imbalance makes the expansion and reinforcement of transmission infrastructures increasingly necessary, in order to ensure adequate power flows from generation-rich areas in the South towards the main load centres

in the North. In this context, High-Voltage Direct-Current (HVDC) solutions represent a key enabler for accommodating large-scale transfers while preserving system security and operational margins.

To ensure the continued reliability and efficiency of a power system undergoing deep transformation and characterized by unprecedented operating conditions, Terna, the Italian Transmission System Operator (TSO), is planning major development interventions on the National Transmission Grid (NTG), consolidated under the “Hypergrid” project [2].

Beyond the reinforcement of the existing transmission infrastructure, the plan foresees the implementation of new power backbones based on High-Voltage Direct-Current (HVDC) technologies (Figure 3).



Figure 3. Overview of the HVDC transmission backbones planned within the Hypergrid project. Colour legend: in grey, existing HVDC backbones (2024); in light blue, new ones by 2030; in blue, by 2035; and in fuchsia, by 2040.

The development of HVDC solutions is considered a preferable option [3] with respect to the upgrade of the existing High-Voltage Alternating-Current (HVAC) systems, especially for lines with high transmission capacities and long distances [4].

Several technological solutions have been analysed to develop the Hypergrid backbones and converter substations; the Voltage Source Converter (VSC) [5] was adopted mainly due to its additional benefits provided to the grid in terms of higher grid stability and flexibility. The combination of LCC, VSC and other solutions such as Multi-level Modular Converters (MMC) is currently being studied to obtain benefits in possible multi-terminal HVDC solutions [6].

With the increasing integration of renewable energy sources and the progressive decommissioning of conventional thermal power plants, the emerging power system—characterized by a growing share of inverter-based resources—is experiencing a significant reduction in system inertia [7]. This condition increases the risk of frequency instabilities and voltage control challenges. In this context, Voltage Source Converter (VSC) technology in HVDC systems offers a promising solution to address some of the limitations of conventional AC transmission networks [8]. VSC-based HVDC links provide accurate

and independent control of active and reactive power, minimize transmission losses, and enable more effective integration of variable renewable energy sources [9,10]. In addition, with Grid-Forming Control functionalities, VSCs can emulate the inertial response of synchronous generators, thereby supporting system stability under low-inertia conditions [11,12]. Appropriate control of HVDC systems can also be beneficial for damping inter-area oscillations [13]. Another useful application is the connection of different synchronous zones, e.g., operating at different frequencies. The same principle can be applied to connect previously identified synchronous zones through HVDC systems to reduce the risk of propagation of cascading failures that could lead to blackout [14,15].

The objective of this paper is to assess the system-level role of HVDC solutions in the long-term evolution of the Italian power system, focusing on security (N and N-1), congestion mitigation, and operational margins under deep renewable penetration and increasing electrification. The analysis is carried out on the real Italian transmission network, as defined in the official Terna's 2025 Development Plan, rather than on a simplified or test system. As a result, the study addresses actual planning challenges, real transmission corridors, and concrete investment options, providing results that are directly applicable to TSO-level decision-making.

The next sections are organized as follows. Section 2 illustrates the operational framework set up to analyse the scenario of future development of the transmission network. Section 3 describes the studies carried out for the steady-state analysis in the scenario defined. Section 4 presents the discussion of the results shown. Section 5 contains the concluding remarks.

2. Methodological Framework for 2040 Grid Modelling and Scenario Definition

To assess the impact of the transmission development projects planned by the Italian TSO, and to identify the main operational challenges of the future power system under deep renewable penetration, a static load-flow analysis methodology was developed. This approach provides a foundational tool for evaluating the adequacy and effectiveness of the planned reinforcements to the National Transmission Grid, particularly in relation to the risk of congestion between Italian Market Zones under stress conditions.

The methodology was implemented using a bottom-up process (Figure 4), starting from the network model as of November 2024, based on the bus admittance matrix and developed through a proprietary software platform. The software enables the integration of structural upgrades and scenario-based modifications to the electrical network topology, facilitating power flow and security analyses for medium- to long-term planning horizons.

The modelling approach based on the bus admittance matrix facilitated the incremental construction of the 2040 scenario, layering development plan projects onto a neutral baseline. This strategy ensured transparency and modularity in simulation, supporting future extensions of the model (e.g., offshore connections).

The forecast 2040 network model was constructed by incorporating the development projects outlined into the Terna's 2025 Development Plan [2]. The analysis focused on the primary transmission grid, comprising 400 kV and 230 kV AC lines and HVDC corridors (both existing and planned), while sub-transmission networks (132–150 kV) were excluded from the study.

The model was further enriched by integrating several classes of planned infrastructure, including:

- New 400/230 kV overhead lines and HVDC backbones;
- Autotransformers at critical substations;
- Synchronous compensators and shunt reactors, as specified in the 2023 Security Plan;

- Retrofits and upgrades to existing elements (e.g., increased current capacity via capital-light interventions);
- AC/DC conversion projects and rationalization of areas;
- Newly planned substations and related AC sections;
- Additional loads due to data centre installations (particularly in Northern Italy) and cold ironing systems at major ports.

In the static load-flow analysis, each HVDC pole is represented through an equivalent AC-side model consisting of two equivalent synchronous generators located at the sending and receiving substations, respectively. These equivalent generators model the AC/DC conversion stations and allow the explicit control of active power transfers between the connected areas. The active power flow through each HVDC pole is coherently assigned according to the planned transmission capacity, while reactive power exchange with the surrounding AC network is optimised to support voltage regulation, in compliance with the converters' capability curves. The HVDC links are therefore modelled as controllable power injections at the AC nodes, consistently with long-term transmission planning practices. The DC transmission line is not explicitly represented in the load-flow model, and DC-side losses are not directly included in the power flow calculation. This modelling choice is appropriate for system-level security and congestion analyses (N and N-1), where the focus is on power flow redistribution, voltage profiles, and operational margins rather than on detailed DC-side or electromagnetic phenomena. Aggregated HVDC losses can be accounted for ex-post through standard loss factors. For a detailed discussion on HVDC modelling approaches—particularly LCC and VSC technologies—in steady-state planning tools, see [16].

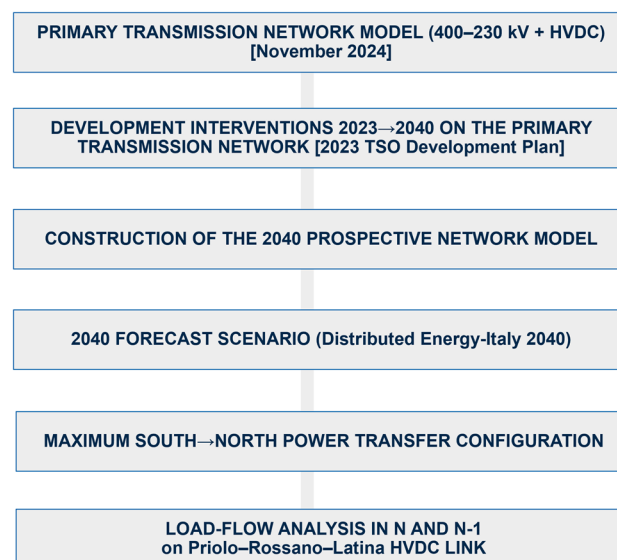

Figure 4. Operational framework for static analysis of the medium- to long-term power system.

The network was simulated under the Distributed-Energy Italy 2040 (DE-IT 2040) scenario, as described in the 2024 Scenario Description Document (DDS24 [17]) jointly published by Terna and the Italian gas infrastructure operator Snam [18]. This scenario aligns with the targets of the 2024 Italian National Integrated Energy and Climate Plan (PNIEC) and the EU's 2050 Net-Zero Strategy, envisioning that 76% of electricity demand, by 2040, will be met by renewable energy sources, with deep electrification of final uses.

The DE-IT 2040 scenario foresees a substantial increase in PV and wind capacity (from current 43 GW to 170 GW at 2040), particularly in Puglia, Calabria, Sicily, and Sardinia. Based on DDS24 projection, the PV capacity is expected to exceed 121 GW, while wind

potential violations of thermal and voltage constraints across the Italian National Electricity Grid (conservative analysis). These static simulations serve as a first-level security screening before more detailed dynamic assessments and are instrumental for evaluating whether planned infrastructure upgrades are sufficient or if further grid developments will be needed in future development cycles.

3. Static Load-Flow Assessment of the Ionian–Tyrrhenian HVDC Backbone

Once the scenario was established, static load-flow analyses were performed on the case study of the Ionian–Tyrrhenian HVDC backbone (Priolo–Rossano–Latina), using proprietary in-house tools adopted within the company, specifically designed for steady-state power system studies (WinCRESO).

Within the framework of the Italian Transmission System Development Plan [2], the proposed HVDC links are not intended to replace conventional AC grid reinforcements, but to complement them at a stage where increasing renewable penetration and power flow concentration make AC-only solutions insufficient. In particular, the Ionian–Tyrrhenian HVDC backbone (Priolo–Rossano–Latina) represents a key infrastructure for system-wide balancing and security. The HVDC corridor enables a significant increase in the interconnection capacity of the Sicily–Calabria and Calabria–Central South sections, allowing the integration of the large amount of renewable generation expected in Southern Italy. At the same time, it strengthens the Calabrian transmission ring—also in coordination with targeted “capital light” AC interventions—and provides a differentiated transmission path for Sicily, enhancing operational security and relieving congestion on the internal networks of Calabria and Sicily. In this context, the HVDC solution becomes necessary when renewable-driven power transfers exceed the sustainable limits of the AC grid, offering controllability, flexibility, and security margins that cannot be achieved through conventional reinforcements alone.

The mentioned project, which fully adopts HVDC VSC technology, comprises two segments:

- HVDC Ionian, a new submarine link between Sicily and Calabria with a transmission capacity up to 1050 MW, connecting the Priolo and Rossano grid nodes.
- HVDC Rossano–Latina, a new link of 2100 MW between the Rossano and Latina, including an overhead-cable transition substation located in the Montecorvino area.

The necessary datasets to represent the forecast 2040 transmission network and the specific network configuration defined by the scenario were loaded into the model.

To reflect the forecast growth of renewable generation in Southern Italy and to assess potential congestion between Market Zones, a localized load reduction was applied in line with the projected power flows. Redispatch actions were modelled as heuristic adjustments to generation levels, based on stress conditions identified in preliminary simulations. The dispatch logic did not follow a strict economic merit order but aimed at maximizing power flow toward the Rossano and Latina nodes during PV peak hours, highlighting the operational relevance of the new DC link in alleviating AC congestion, especially in the Calabrian AC loop of the transmission grid. Once the model was set, the simulation was executed under N conditions.

Under N conditions (Figure 6), the AC interconnection between Sicily (SIC) and Calabria (CAL) operates without any violation of operational constraints or criticalities, with flows of about 2.6 GW from Sicily to Calabria and 1.25 GW from Calabria to the South.

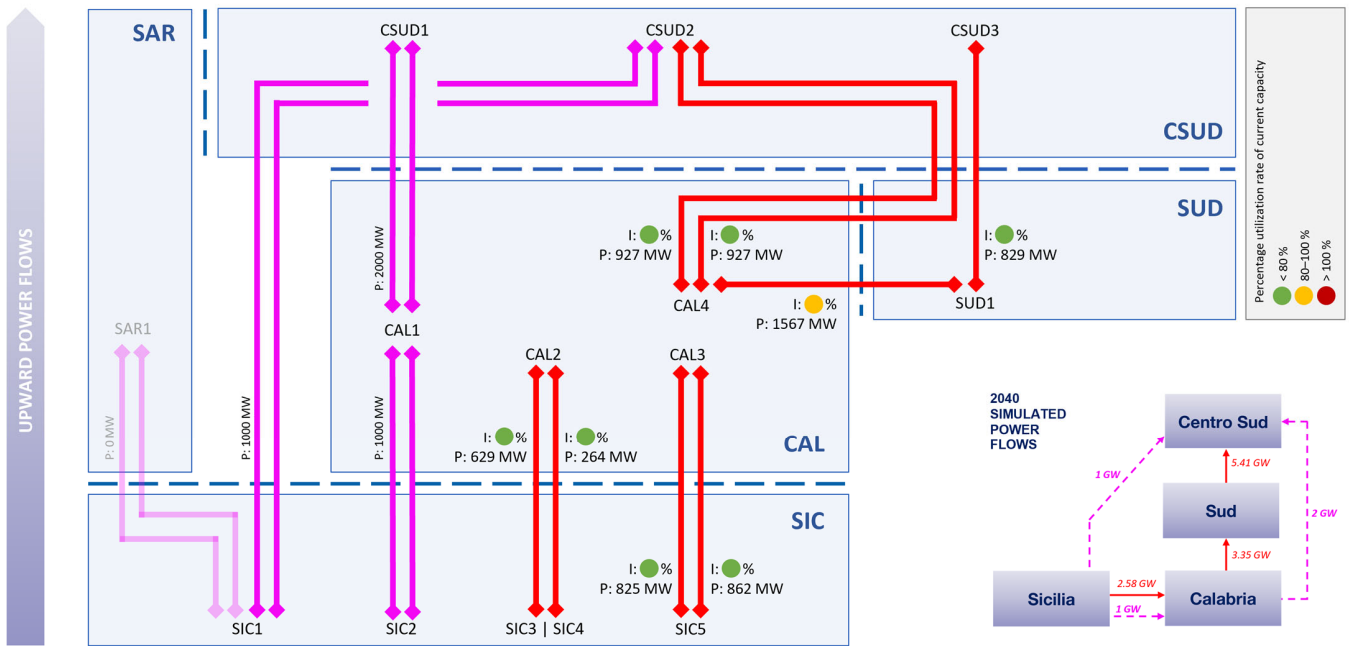

Figure 6. Load-Flow Results under N Conditions. Colour legend: AC links in red, HVDC links in fuchsia.

Line loadings remain moderate (e.g., SIC3 at 825 MW, SIC5 at 862 MW, CAL4 at 1567 MW) and all utilization indicators are below 50% (well below thermal limits), ensuring an overall security margin consistent with planning criteria.

To analyse the redistribution of power flows under a potential contingency, an N-1 simulation was performed, simulating the loss of one of the two future 525 MW HVDC poles between Priolo and Rossano.

In the N-1 scenario (Figure 7), which also accounts for an appropriate curtailment of renewable generation, a significant redistribution of power flows is observed. The power transfer on the AC grid between Sicily and Calabria increases up to around 3 GW, corresponding to a loading level close to 80–85% of the thermal capacity of the three existing links (SIC5 reaches 1028 MW, SIC3 983 MW, and CAL3 approaches 943 MW). The 400 kV lines with lower capacity in the Calabria region approach high utilization levels, with some exceeding 90% of their rated capacity, although without outright violations. The N-1 simulation also revealed that the HVDC backbone—when fully operational—ensures a more uniform distribution of power across Sicilian nodes, reducing stress on AC corridors. However, its unavailability shifts the power flows onto AC backbones, exposing them to potential overloads and reducing the remaining transmission capacity (RTC) margin to values below 15% on critical paths.

Despite the absence of immediate violations, these loading patterns underscore the need for improved coordination between AC reinforcements and HVDC dispatch capabilities. Additional sensitivity analyses, considering simultaneous contingencies such as the loss of one HVDC pole and a critical 400 kV line, revealed that overloads could occur near the southern boundary of the Central-South (CSUD) Market Zone. This highlights the potential benefit of real-time flow control based on coordinated AC/DC management and advanced security indicators (e.g., N-1 security factor), which are identified as promising directions for future work.

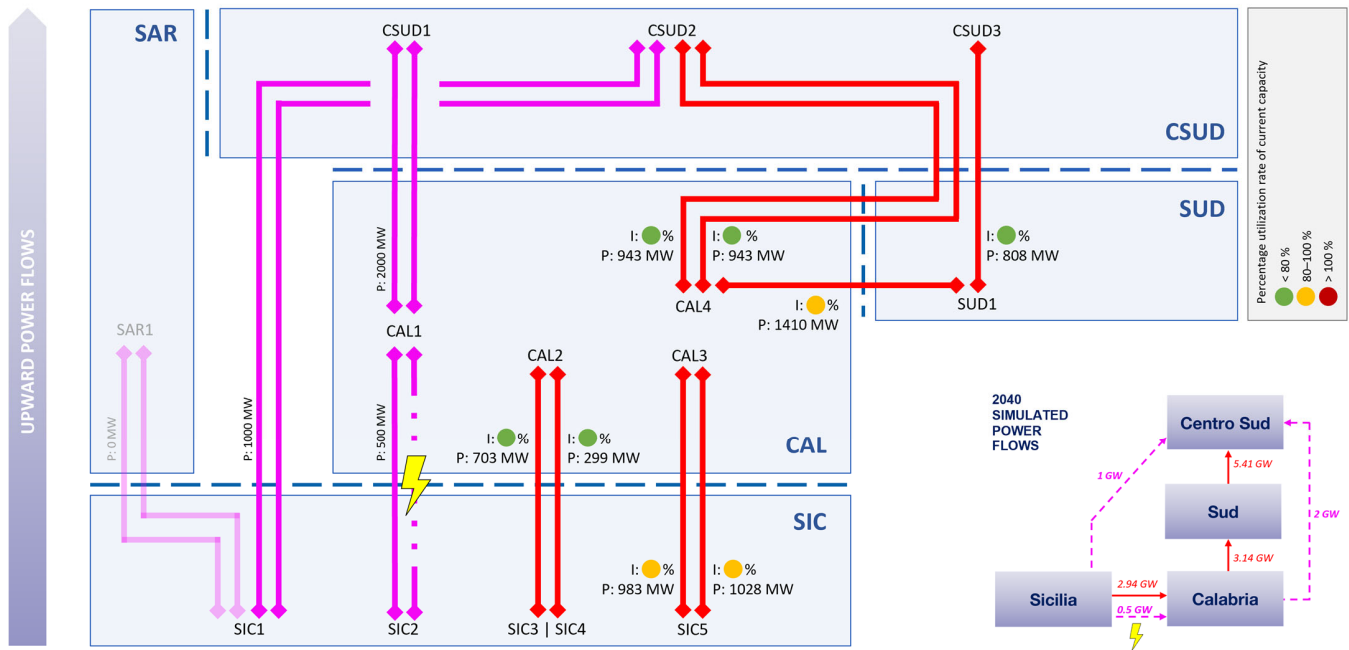

Figure 7. Load-Flow Results under N-1 Conditions. Colour legend: AC links in red, HVDC links in fuchsia. The yellow symbol indicates the faulted line.

4. System-Level Insights: AC/DC Coordination, Security, and Future Challenges

The steady-state simulations conducted under both N and N-1 conditions highlight the strategic relevance of the HVDC Priolo–Rossano–Latina backbone in supporting north-bound power transfers and relieving congestion on the AC grid, particularly under high PV and wind generation scenarios. The backbone enables significant renewable injections from Southern Italy while maintaining operational margins on the Sicily–Calabria and Calabria–South corridors. However, the N-1 analysis—specifically the loss of one HVDC pole—reveals a redistribution of flows that increases the loading on several 400 kV lines in Calabria, although no thermal violations are observed within the modelled reinforcements. These findings suggest that the system remains sensitive to partial HVDC unavailability, especially during periods of high renewable output and low local demand, underscoring the need to evolve from a static “bulk transfer” view of HVDC to a more dynamic and coordinated AC/DC operational paradigm.

In this context, a security-constrained AC/DC co-optimization framework emerges as a promising solution. By jointly solving for HVDC active and reactive power set-points alongside AC redispatch, and embedding thermal and voltage constraints, the system can reduce preventive curtailments and enhance N-1 security margins. This approach requires a rolling optimization horizon, aligned with the TSO’s Dynamic Security Assessment processes, and positions HVDC not as a passive conduit but as an active lever for system security. The integration of Wide-Area Monitoring Systems (WAMS) further enhances this capability: real-time PMU data can be used to detect inter-area oscillations and adapt HVDC set-points, accordingly, improving damping and avoiding overloads on critical corridors such as the Sicily–Calabria interconnections and the Calabria loop. This adaptive control reduces reliance on conservative pre-contingency curtailments and mitigates bottlenecks at the CSUD boundary.

While the steady-state results confirm the adequacy of the planned infrastructure, dynamic stability remains a critical area for further investigation. In particular, the deployment of Grid-Forming (GFM) control strategies on VSCs could provide synthetic inertia and voltage support in weak-grid areas like Sicily and Calabria. In stronger grid regions,

conventional Grid-Following modes with STATCOM-like behaviour may suffice, but in weaker zones, properly tuned GFM operation could significantly enhance system resilience to disturbances.

Moreover, the evolving load landscape—driven by the growth of data centers in the North and cold ironing systems in major ports—will reshape evening demand profiles and influence HVDC dispatch strategies. Coordinated operation of HVDC links with battery energy storage systems (BESS) and green hydrogen electrolyzers can facilitate the temporal shifting of excess mid-day renewable generation to evening hours, alleviating stress on the CSUD boundary and improving N-1 security. This calls for integrated planning approaches that co-optimize generation, storage, flexible demand, and transmission infrastructure, rather than treating them as isolated components.

Nonetheless, the current study has the following limitations:

- i. The 2040 network model focuses on the primary grid (400/230 kV), excluding sub-transmission levels (132–150 kV), which may lead to underestimation of intrazonal congestion and reactive power challenges. Future work should extend the model to include these layers for more accurate loss estimation and constraint analysis.
- ii. Additionally, the simplified steady-state representation of VSCs and the treatment of HVDC losses omit small-signal and transient dynamics, suggesting the need for hybrid simulation frameworks that couple power-flow analysis with modal and EMT studies.
- iii. The lack of spatial granularity for offshore wind, BESS, and electrolyzers also limits the fidelity of redispatch modelling, which could be improved by incorporating candidate nodes and security-constrained OPF formulations with AC/DC and reactive power variables.

Finally, given the stochastic nature of renewable generation and demand, a shift from deterministic to probabilistic planning is essential. This involves generating ensembles of PV, wind, and load profiles (e.g., P10–P90 bands), computing risk-of-violation metrics that combine probability and severity and assessing N-1 margin sensitivity under tail scenarios. Embedding these capabilities into a rolling SCOPF framework, with endogenous HVDC set points and real-time interzonal limits derived from state estimation and WAMS, will be key to ensuring a secure and efficient transition to a deeply decarbonized Italian power system.

5. Conclusions

This study confirms the strategic role of the HVDC Priolo–Rossano–Latina backbone in enhancing northbound transfer capability and mitigating congestion on the AC grid under both N and N-1 conditions in a 2040 scenario with deep RES penetration. The results underscore the importance of moving toward a new operational paradigm where AC/DC coordination becomes the default. Implementing a security-constrained optimal power flow (OPF) that includes endogenous HVDC set-points and real-time interzonal limits can significantly reduce preventive curtailments of renewable energy—particularly during mid-day PV peaks—and increase the N-1 security margin along the Sicily–Calabria–CSUD corridors.

The HVDC corridors analysed in the paper are not conceived as an alternative to the AC grid reinforcements envisaged in the Development Plan, but as a complementary and enabling infrastructure that becomes necessary at an advanced stage of system evolution. As renewable penetration and regional imbalances increase, conventional AC reinforcements alone are no longer sufficient to ensure adequate transfer capacity, security margins, and operational flexibility.

In particular, the HVDC backbone plays a system-balancing role, enabling large-scale power transfers from Southern Italy—where significant renewable capacity is expected—to

the main load centres in Central and Northern Italy, while simultaneously reinforcing structurally weak sections of the AC grid.

To further improve system resilience, the transition from deterministic to probabilistic security assessments is essential. By generating P10–P90 congestion maps and quantifying risk through probability–severity metrics, operators can better prioritize critical bottlenecks and identify cost-effective mitigation strategies. In parallel, advanced control strategies should be selectively deployed where they offer the greatest value: for instance, piloting wide-area monitoring system (WAMS)-based HVDC control and grid-forming (GFM) converters in weak-grid areas such as Sicily and Calabria, while maintaining conventional grid-following modes in stronger regions. These technologies can enhance oscillation damping and improve frequency containment, contributing to overall system stability.

The evolving load landscape also demands attention. The increasing presence of data centers in Northern Italy and cold ironing systems in major ports will reshape evening demand profiles, requiring co-optimization of HVDC, BESS, electrolysers, and flexible loads to relieve stress on the CSUD boundary after sunset. This integrated approach to planning and operations ensures that emerging consumption patterns are addressed proactively.

Looking ahead, the development of a hybrid static–dynamic analysis workflow—combining steady-state simulations with small-signal and targeted EMT studies—will be crucial. Extending the network model to include the 132–150 kV sub-transmission level will allow for more granular assessments of intrazonal constraints, reactive power exchanges, and system losses. Ultimately, embedding these capabilities into a rolling SCOPF framework, enriched by real-time data from state estimation and WAMS, will support a more adaptive and secure operation of the future Italian power system.

In summary, this work not only demonstrates the technical benefits of the HVDC backbone in a future-oriented grid model but also frames a broader vision: HVDC infrastructure must evolve from a passive transfer medium to an active, coordinated security asset, integrated with probabilistic planning, wide-area feedback, and advanced converter controls. The proposed steady-state framework offers a practical foundation for this transition, guiding both infrastructure development and operational strategies toward a resilient, hybrid AC/DC grid.

Author Contributions: Conceptualization, methodology, validation, formal analysis, investigation, resources, data curation, writing—original draft preparation, writing—review and editing, supervision: C.F., C.M., P.C., A.U., A.Z., L.B. and G.C. All authors have read and agreed to the published version of the manuscript.

Funding: This research received no external funding.

Data Availability Statement: The datasets presented in this article are not readily available because of privacy restrictions.

Conflicts of Interest: Authors Claudio Ferrara, Carmelo Mosca, Paolo Cuccia, Andrea Urbanelli, Antonio Zanghì, Luca Belmonte were employed by the company Terna S.p.A. The remaining author declares that the research was conducted in the absence of any commercial or financial relationships that could be construed as a potential conflict of interest.

References

1. Terna. Connections. Available online: <https://dati.terna.it/econnexion> (accessed on 23 December 2025).
2. Terna. National Transmission Grid Development Plan 2025 (Piano di Sviluppo 2025, in Italian). Available online: <https://www.terna.it/it/sistema-elettrico/programmazione-territoriale-efficiente/piano-sviluppo-rette> (accessed on 23 December 2025).
3. Wang, M.; An, T.; Ergun, H.; Lan, Y.; Andersen, B.; Szechtman, M.; Leterme, W.; Beerten, J.; Van Hertem, D. Review and outlook of HVDC grids as backbone of transmission system. *CEE J. Power Energy Syst.* **2021**, *4*, 797–810. [[CrossRef](#)]

4. Alassi, A.; Bañales, S.; Ellabban, O.; Adam, G.; MacIver, C. HVDC Transmission: Technology Review, Market Trends and Future Outlook. *Renew. Sustain. Energy Rev.* **2019**, *112*, 530–554. [[CrossRef](#)]
5. Xu, R.; Jiang, Q.; Li, B.; Liu, Y.; Liu, T.; Blaabjerg, F.; Wang, P. Impedance based Stability Analysis of the Multi-terminal Cascaded Hybrid HVDC System. *IEEE Trans. Power Deliv.* **2025**, *40*, 1754–1768. [[CrossRef](#)]
6. Alrajhi, H.; Daraz, A.; Alzahrani, A.; Babsail, H.; Alharbi, Y.; Alsharif, F.; Alattas, A.; Alshammari, K. Power Sharing Control Trends, Challenges, and Solutions in Multi-Terminal HVDC Systems: A Comprehensive Survey. *IEEE Access* **2024**, *12*, 69112–69129. [[CrossRef](#)]
7. Lasseter, R.H.; Chen, Z.; Pattabiraman, D. Grid-Forming Inverters: A Critical Asset for the Power Grid. *IEEE J. Emerg. Sel. Top. Power Electron.* **2020**, *8*, 925–935. [[CrossRef](#)]
8. Lauria, D.; Mottola, F.; Grieco, G.; Pisani, C.; Giannuzzi, G. Power System Resilience Improvement Provided by VSC-HVDC Link Flexibility. In *Proceedings of the 2023 AEIT HVDC International Conference (AEIT HVDC), Rome, Italy, 25–26 May 2023*; IEEE: New York, NY, USA, 2023; pp. 1–6. [[CrossRef](#)]
9. Mosca, C.; Bompard, E.; Aluisio, B.; Migliori, M.; Vergine, C.; Cuccia, P. HVDC for frequency stability under RES penetration: The Sardinia Island case. In *Proceedings of the 2019 AEIT HVDC International Conference (AEIT HVDC), Florence, Italy, 9–10 May 2019*; IEEE: New York, NY, USA, 2019; pp. 1–6.
10. Camarillo-Peñaranda, J.R.; Cunha, A.C.; França, B.W.; de Abreu Oliveira, F.; de Oliveira Senna, L. A review on VSC-HVDC control schemes. *Annu. Rev. Control* **2025**, *59*, 100988. [[CrossRef](#)]
11. Mosca, C.; Arrigo, F.; Mazza, A.; Bompard, E.; Carpaneto, E.; Chicco, G.; Cuccia, P. Mitigation of frequency stability issues in low inertia power systems using synchronous compensators and battery energy storage systems. *IET Gener. Transm. Distrib.* **2019**, *13*, 3951–3959. [[CrossRef](#)]
12. Derviskadic, A.; Persico, A.; Isabegovic, E.; Thorslund, A. Opportunities and Challenges in the Mediterranean Region with Grid Forming Control for HVDC Systems. In *Proceedings of the 2023 AEIT HVDC International Conference (AEIT HVDC), Rome, Italy, 25–26 May 2023*; IEEE: New York, NY, USA, 2023; pp. 1–6. [[CrossRef](#)]
13. Vural, A.M. Contribution of high voltage direct current transmission systems to inter-area oscillation damping: A review. *Renew. Sustain. Energy Rev.* **2016**, *57*, 892–915. [[CrossRef](#)]
14. Mosca, C.; Bompard, E.; Chicco, G.; Moreira, J.; Sermanson, V.; Power, D. Frequency Stability of the European Interconnected Power System Under Grid Splitting in Market Zones. *Energy Syst. Res.* **2020**, *3*, 37–47. [[CrossRef](#)]
15. Gomila, D.; Carreras, B.A.; Reynolds-Barredo, J.M.; Martínez-Barbeito, M.; Colet, P.; Gomis-Bellmunt, O. Reducing Blackout Risk by Segmenting European Power Grid with HVDC Lines. *J. Mod. Power Syst. Clean Energy* **2025**, *13*, 1556–1567. [[CrossRef](#)]
16. Michi, L.; Donnini, G.; Capurso, P.; Caldarulo Bugliari, A.; Falorni, F.; Quadrio, M.; Canever, D.; Giorgi, L. An overview of the HVDC transmission system models in planning tools: The Italian experience. In *Proceedings of the 2019 AEIT HVDC International Conference (AEIT HVDC), Florence, Italy, 9–10 May 2019*; IEEE: New York, NY, USA, 2019; pp. 1–6. [[CrossRef](#)]
17. Terna-Snam. Scenario Description Document 2024 (Documento di Descrizione degli Scenari 2024, in Italian). Available online: <https://www.terna.it/en/electric-system/efficient-territorial-planning/national-electricity-transmission-grid-development-plan/scenario> (accessed on 23 December 2025).
18. Snam. Available online: <https://www.snam.it/en/home.html> (accessed on 23 December 2025).

Disclaimer/Publisher’s Note: The statements, opinions and data contained in all publications are solely those of the individual author(s) and contributor(s) and not of MDPI and/or the editor(s). MDPI and/or the editor(s) disclaim responsibility for any injury to people or property resulting from any ideas, methods, instructions or products referred to in the content.