

Impact of demand response and network payment schemes on generation and transmission expansion planning with high renewable energy penetration

*Original*

Impact of demand response and network payment schemes on generation and transmission expansion planning with high renewable energy penetration / Ahmad, Shehzad; Numan, Muhammad; Salam, Izhar Us; Yousif, Muhammad. - In: SUSTAINABLE ENERGY TECHNOLOGIES AND ASSESSMENTS. - ISSN 2213-1388. - 87:(2026).  
[10.1016/j.seta.2026.104882]

*Availability:*

This version is available at: 11583/3007785 since: 2026-02-19T16:57:27Z

*Publisher:*

Elsevier

*Published*

DOI:10.1016/j.seta.2026.104882

*Terms of use:*

This article is made available under terms and conditions as specified in the corresponding bibliographic description in the repository

*Publisher copyright*

(Article begins on next page)

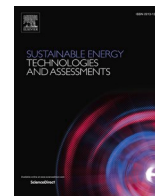

## Original article

# Impact of demand response and network payment schemes on generation and transmission expansion planning with high renewable energy penetration

Shehzad Ahmad <sup>a,b,\*</sup> , Muhammad Numan <sup>a</sup> , Izhar Us Salam <sup>a,c</sup> , Muhammad Yousif <sup>a</sup> 

<sup>a</sup> Department of Electrical Power Engineering, US-Pakistan Center for Advanced Studies in Energy, National University of Science and Technology, 44000 Islamabad, Pakistan

<sup>b</sup> Dipartimento di Elettronica, Informazione e Bioingegneria, Politecnico di Milano, Milan, Italy

<sup>c</sup> Dipartimento Energia "Galileo Ferraris", Politecnico di Torino, Corso Duca degli Abruzzi 24, 10129 Torino, Italy

## ARTICLE INFO

## Keywords:

Network expansion planning  
 Generation expansion planning  
 Transmission expansion planning  
 Network payment schemes  
 Transmission System  
 Renewable energy

## ABSTRACT

Network Expansion Planning (NEP) plays a pivotal role in the development of power systems. It involves investing in new generating units and transmission lines to meet growing load demands and ensure a reliable electricity supply. Historically, the incorporation of demand response (DR) factors in power system planning has been limited due to their complexity and evaluation challenges. However, with advancements in smart grid technologies, increased integration of renewable energy, and the emergence of flexible loads, the inclusion of DR models has become crucial for enhancing power system reliability. While numerous studies have delved into generation and transmission expansion planning (GTEP) problems, only a few have explored the integration of network payment schemes and DR within the GTEP framework. This study proposes a multi-annual generation and transmission expansion planning model that incorporates three network payment schemes and two DR techniques. The objective is to secure financing for new generating units and transmission lines while minimizing the overall system cost. The proposed models employ the mixed-integer linear programming (MILP) optimization method and are validated using a modified IEEE 24-bus system. Two key system performance metrics, namely the network congestion index and network saturation index, are employed to assess system reliability and effectiveness. These results demonstrate that the integration of network payment schemes and DR techniques into the generation and transmission expansion planning model can lead to a cost reduction of 32.1% as compared to base model, reduced power system congestion and saturation (22.1%, 2.73%) to allow more renewable energy integration and enhanced power system reliability and operational flexibility.

## Introduction

Network expansion planning (NEP) for power generation and transmission plays a pivotal role in upgrading the existing power infrastructure, given the increasing integration of renewable energy sources (RES) and dynamic system operating conditions. NEP involves investment in generating units and transmission lines to meet growing demand and ensure a reliable electricity supply. However, uncertainty about future load growth, innovations in smart grid technologies, and increased renewable energy integration require the NEP to incorporate diverse DR factors and payment schemes to enhance the efficiency and reliability of the power system. Additionally, the traditional planning approach, which relies on peak demand forecasts, struggles to mitigate

the variability introduced by renewable generation, making DR an emerging solution [1]. To fully take advantage of DR in NEP, it is necessary to develop a market-based economic framework that sends accurate cost and value signals to all market participants through network payment schemes. The existing payment schemes for network systems, such as the postage scheme and power flow distance methods, lacked a payback mechanism after investment, leading to inefficiencies in the transmission system's expansion and in the deregulation of the electricity market. A transmission line recovery cost is introduced in the network payment scheme model to enhance the efficiency of NEP and regulate the electricity market [2]. NEP mainly comprises generation and transmission expansion planning. Generation expansion planning (GEP) minimizes the investment cost over the planning horizon by providing an optimal plan for building conventional and renewable

\* Corresponding author.

E-mail address: [shehzad.ahmad@polimi.it](mailto:shehzad.ahmad@polimi.it) (S. Ahmad).

<https://doi.org/10.1016/j.seta.2026.104882>

Received 18 August 2025; Received in revised form 20 December 2025; Accepted 8 February 2026

Available online 18 February 2026

2213-1388/© 2026 The Author(s). Published by Elsevier Ltd. This is an open access article under the CC BY license (<http://creativecommons.org/licenses/by/4.0/>).

Nomenclature			
<i>Abbreviations</i>			
DR	Demand Response	$M_k$	Big-M value is used to take a line out from the system
GEP	Generation Expansion Planning	$\vartheta$	Postage stamp transmission tariff
GTEP	Generation and Transmission Expansion Planning	$\nu$	Per-power-flow transmission tariff
MILP	Mixed Integer Linear Programming	$\gamma$	Per-power-flow-distance transmission tariff
NCI	Network Congestion Index	$\sigma_{lts}, \sigma_{kts}$	Total length of existing and candidate transmission lines
NSI	Network Saturation Index	$\theta_{bts}$	Load curtailment incentive cost at bus b in time t under scenario s
LS	Load Shifting	$\tau_{bts}$	Load shifting incentive cost at bus b in time t under scenario s
LC	Load Curtailment	$\infty_{bts}$	Percentage of load curtailment at bus b in time t under scenario s
NPS	Network Payment Scheme	$d$	Annual discount rate
PS	Postage Stamp	<i>Variables</i>	
PPF	Per-power-flow	$P_{gts}^g$	Power generated by existing generating units at time t under scenarios
PPFD	Per-power-flow-distance	$P_{cts}^c$	Power generated by candidate generating units at time t under scenarios
TEP	Transmission Expansion Planning	$P_{lts}^l$	Power flow in existing lines at time t under scenarios
<i>Sets / Indices</i>		$P_{kts}^k$	Power flow in candidate lines at time t under scenarios
$\Omega^T$	Number of planning years	$\chi_{cts}$	Binary variable that is equal to 1, if new generator is constructed, else 0
$\Omega^G$	Number of existing generators	$\Omega_{bts}$	Power curtailed at bus b in time t under scenarios
$\Omega^{C_s}$	Number of candidate generators	$\zeta_{bts}$	Power shifted at bus b in time t under scenarios
$\Omega^L$	Number of existing transmission lines	$\delta_{bts}$	Voltage angle at bus b in time t under scenarios
$\Omega^{C_l}$	Number of candidate transmission lines	$\phi_{lts}, \phi_{kts}$	Transmission line usage ratio of existing and candidate lines, while using Postage stamp payment scheme.
$\Omega^S$	Number of scenarios	$y_{kts}$	Binary variable that is equal to 1, if new line is built at time t under scenario s, else 0
<i>Parameters</i>		$\alpha_{kts}$	Binary variable that is equal to 1, if new line IRP is not completed, else 0
$C_c^{inv}$	Investment cost of candidate generating units	$x_{kts}$	Binary variable that is equal to 1, if line working on maximum capacity, else 0
$C_g^{op}$	Operational cost of existing generating units		
$C_c^{op}$	Operational cost of candidate generating units		
$C_k^{inv}$	Investment cost of candidate transmission lines		
$C_l^{op}$	Operational cost of existing transmission lines		
$C_k^{op}$	Operational cost of candidate transmission lines		
$B_l, B_k^C$	Susceptance of existing and candidate lines		

generating units [3,4]. The construction of new generation units places an additional burden on transmission lines, as excessive amounts of power are transmitted to consumers. This problem is overcome by locating and installing optimal candidate lines to prevent network congestion through transmission expansion planning (TEP) [5–7].

The increased integration of renewable energy into the power system has significantly changed its uncertainty and economic efficiency, influencing both planning and operational decisions. These shifts have increased research interest in coordinated strategies for generation and transmission expansion that can handle high RES penetration. For instance, based on congestion indicators, a transmission expansion model is proposed in [8] to reflect market conditions and changes in price signals, effectively reducing investment costs for constructing new transmission lines. Further, for resolving the transmission expansion problem with renewable energy in the long term, a two-step approach is implemented in [9] for short-term demand and supply management and long-term investment decisions. In the first step, the capacities of power generation facilities, along with the transmission routes and voltage capacity, are determined. The second step addresses dynamic changes in demand and supply, which are managed through flexible operation dispatch and dynamic power flow operations. Also, a two-level TEP problem is modelled in [10], in which the first stage considers transmission expansion planning followed by the generation investment phase. The system’s profits, such as revenue from the transmission investment, were maximized in the first phase, while in the second phase, a central planning model concurrently resolves both market operation and generation investment. This differentiation allows for more precise modelling of operational flexibility and revenue effects, helping to make

strategic investment choices across different planning periods..

Similarly, a wide range of optimization techniques is used in GTEP. Meta-model assisted evolutionary algorithms and hybrid metaheuristics help reduce total system costs and handle large search spaces in expansion planning [11]. Coordinated generation–transmission models that aim to minimize combined investment, operational, and penalty costs have been reported in [12] through an optimization objective approach. Additionally, mixed-integer linear programming (MILP) formulations are common in TEP research, often enhanced to include realistic cost factors, such as line recovery and different payment types, to better reflect economic trade-offs [2 13]. Moreover, distributed energy resources (DERs) and flexibility assets such as DR schemes, renewable virtual power plants, and electric vehicles (EVs), in the power network are also included in expansion planning. Therefore, hybrid optimization techniques incorporating DR strategy and EVs can enhance distribution system flexibility and resilience up to 95% as reported in [14]. Further, in [15] a distributionally robust optimization model is proposed to curtail transmission network expansion cost under uncertainty and increase renewable generation penetration level. Also, the multi-stage stochastic optimization based on GTEP has been applied for achieving optimal expansion planning by effectively utilizing existing generation capacity and unlocking suppressed demand through strategic investments in both transmission and generation [16]. This strategy can help in a trade-off between prioritizing surplus generation and TEP. Moreover, an AC power flow-based integrated GTEP framework is proposed in [17], which jointly co-optimizes generation siting, transmission expansion, reactive power allocation, and loss minimization for providing more realistic expansion planning. Additionally, using

**Table 1**  
Comparison of literature and current study.

Reference	GEP	TEP	NPS	LC	LS
[2,13]	×	✓	✓	×	×
[3,4]	✓	×	×	×	×
[7]	✓	✓	×	×	×
[22]	✓	✓	×	✓	✓
[24]	✓	✓	×	✓	✓
[25]	✓	✓	×	✓	×
[27]	✓	×	×	✓	✓
[31]	×	×	✓	×	×
[33]	×	×	✓	×	×
Current Study	✓	✓	✓	✓	✓

reliability-constrained formulations that combine load and RES projection with Monte Carlo simulation under N-1 contingency constraints further demonstrates hybrid methods for ensuring system reliability along with enhancement in voltage profile and reducing power losses [18].

Furthermore, DR has become an essential flexibility resource in expansion planning, helping to reduce network congestion, support renewable energy generation, lower peak flows, and enhance reliability and economic outcomes when explicitly included in planning models. DR programs generally fall into two categories: price-based options such as time-of-use, real-time pricing, and critical pricing, and incentive-based options, such as load curtailment (LC) and load shifting (LS) that provide payments for load curtailment or shifting [19,20]. Both types are utilized in planning research to incorporate consumer-side flexibility. For example, an incentive-based DR TEP model with a probabilistic approach is introduced in [21] for tackling the variability and uncertainty factors associated with a grid-connected wind farm. Similarly, a DR approach based on load shifting and curtailment is incorporated into a MILP-based TEP model in [22,23]. Instead of using traditional load-duration curves, load blocks are utilized to reduce computational complexity. The results indicate notable enhancements in system reliability, operational efficiency, and overall economic gains. In [24], a power system investment model based on a stochastic investment planning model is presented, which uses DR to minimize the need for costly energy storage investments. Moreover, the DR scheme, combined with GTEP, is used to develop an optimal expansion strategy for power systems, assisting system planners in deciding on investments that meet electricity demand, reducing emissions, and controlling costs, while increasing the use of RES [25]. In [26], an advanced generation expansion planning framework is introduced that accounts for the increasing use of distributed generation resources, both thermal and renewable, along with load-management benefits and DR procedures. For transmission networks discussed in [27], a mixed-integer nonlinear TNEP model that includes long-term DR indicates that demand-side flexibility influences line loading, failure rates, and system reliability. It also helps mitigate congestion and lowers local marginal price (LMP) inflation. When tested on the IEEE 24-bus reliability system, the model showed that DR can reduce the need for new transmission lines, stabilize LMP profiles, and enhance the overall value of the transmission system across various scenarios. In [28], the consequences of the market-based DR method on system reliability in emergencies were discussed. The author investigated the DR method as a solution for increasing power system reliability in the presence of an uncertain renewable energy resource.

Additionally, transmission cost allocation and market mechanisms are typically studied alongside expansion models [29,30]. Various methods, such as composite marginal transmission pricing, user-benefit-based allocations, and two-stage frameworks, have been developed to avoid overinvestment and promote fair sharing of economic gains among market players [31,32]. Comparative studies of transmission cost-allocation schemes across different market structures and wheeling setups show that the choice of allocation method, whether composite

marginal pricing, megawatt-mile variants, or dominant/reverse absolute approaches, can greatly affect how network charges are distributed, the fairness of user contributions, and the strength of investment signals, thereby impacting the long-term sustainability of transmission systems [33,34].

NEP problem is generally studied from different scales, such as reliability [35], electricity market [36] and renewable energy penetration [37] from the past few years. Conventional techniques used for NEP are based on linear programming [38] and heuristic methods such as ant colony optimization [39], genetic algorithm [26], and benders decomposition [40,41]. Renewable energy and demand uncertainties-based transmission expansion planning was described in [42]. These models were validated on IEEE systems and use hybrid algorithms to reduce costs, enhance reliability, and maximize income.

Correlation of the above literature review and the current study is mentioned in Table 1. As discussed, both GTEP and DR methods are efficient in reducing total network cost, relieving power system congestion, improving power system reliability, and facilitating RES integration. Both techniques (GTEP & DR) are beneficial in coordination with each other, but they are not analyzed with NPS. Some recent research articles have stated around 200 papers during the last ten years to present a quantitative measure of the trends that GTEP, NPS, and DR have concentrated [2,7,23,31].

Literature reviews presented in these research papers show that no study has analyzed GTEP, NPS, and DR together in coordination to facilitate large-scale RES integration. Therefore, this research gap is filled by exhibiting an evaluation model that coordinates GTEP, NPS, and DR to analyze their collaborative effects on total system cost, RES integration, and network congestion relief by utilizing mixed integer linear programming (MILP). This paper examines a novel investment and optimization expansion planning model. The main contributions of the paper are summarized below:

- Coordinating a MILP model that solves a generation and transmission expansion model for a multi-year period, while considering high renewable energy penetration.
- Integrating multiple network payment methods with the GTEP model to maximize profit for market players in terms of line recovery cost.
- Investigating the impact of DR, including load curtailment and load shifting plans, on the GTEP model.
- Proposing a model of DR plan with GTEP and NPS to analyze their impacts on system reliability.

The remainder of the paper is organized as follows: Section 2 briefly describes the methodology and model formulation with various constraints and objective functions for evaluation. Section 3 explains the test system data, such as the IEEE 24-bus system. Section 4 describes the analysis of the results of simulation work to show the performance of the proposed model on the operational cost of the network. Section 5 describes the discussion on the results. Finally, the conclusion and future research directions are provided in Section 6.

## Methodology

### Base model

The formulation of [7] inspires the proposed GTEP model. In this paper, a linear DCOPT problem having negligible system losses is assumed and the losses are not considered due to their negligible values. Generating units ramping and stability constraints are also not incorporated in the proposed model as to maintain the balance between solution accuracy and computational cost. Generators and transmission lines investment decisions can be made in any year of the planning period. Block diagram of proposed model is mentioned in Fig. 1 and proposed mathematical formulation corresponds to:

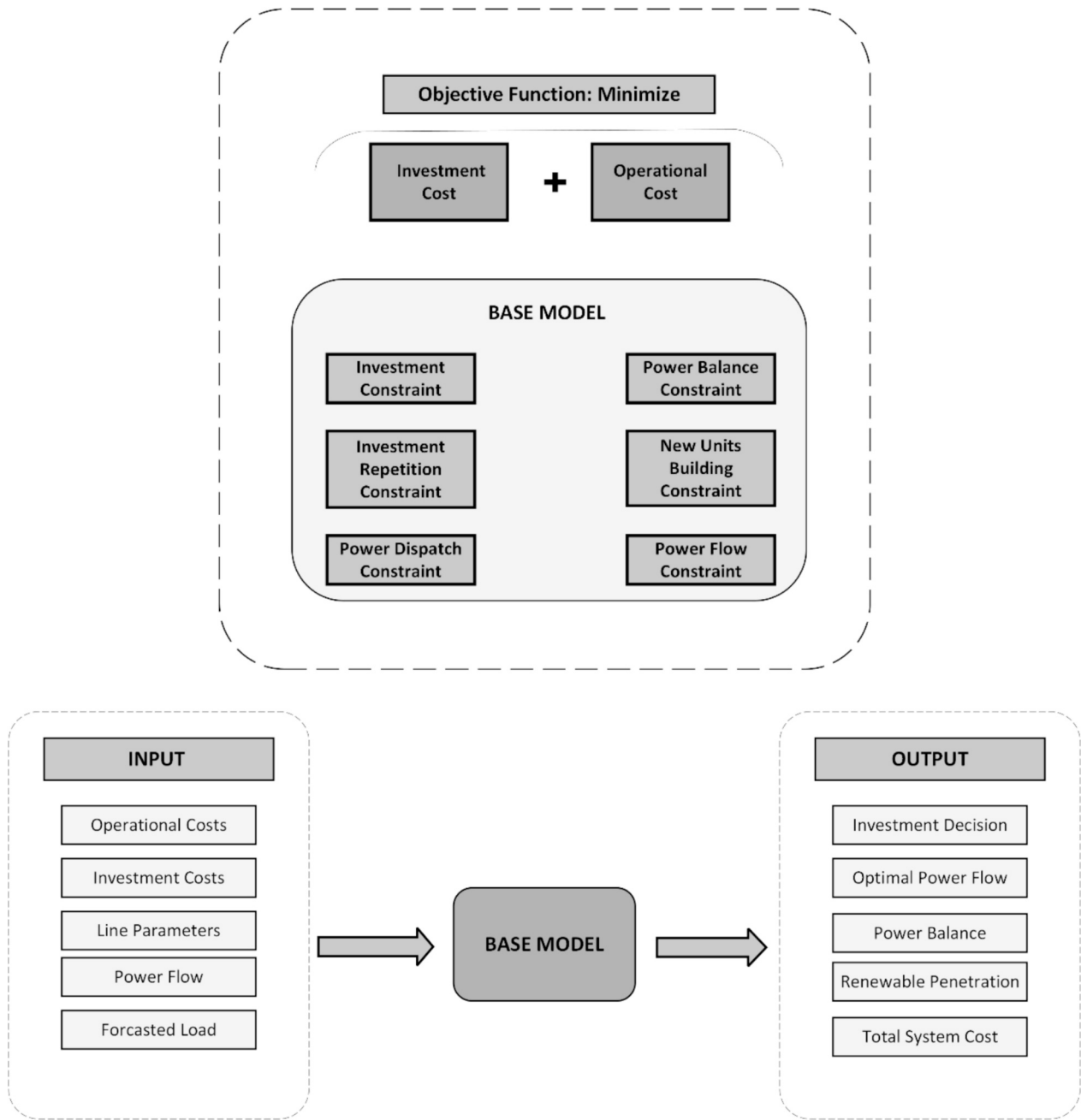

Fig. 1. Block Diagram of proposed model.

$$C^g = \sum_{t \in \Omega^T} \frac{1}{(1+d)^{t-1}} \left[ \sum_{c \in \Omega^{C^g}, s \in \Omega^S} C_c^{inv} \chi_{cts} + \sum_{g \in \Omega^G} C_g^{op} P_{gts}^g + C_c^{op} P_{cts}^c \right] \quad (1)$$

$$C^l = \sum_{t \in \Omega^T} \frac{1}{(1+d)^{t-1}} \left[ \sum_{k \in \Omega^{C^l}, s \in \Omega^S} C_k^{inv} \gamma_{kts} + \sum_{l \in \Omega^L} C_l^{op} + C_k^{op} \alpha_{kts} \right] \quad (2)$$

$$C = C^g + C^l$$

minimize C

Subject to:

$$\chi_{cs(t-1)} \leq \chi_{cts} \quad \forall c \in \Omega^{C^g}, t \in \Omega^T, s \in \Omega^S, t \geq 2 \quad (4)$$

$$\sum_{c \in \Omega^{C^g}} \sum_{s \in \Omega^S} \chi_{cts} \leq \chi_{cts}^{max} \quad \forall t \in \Omega^T \quad (5)$$

$$\chi_{cts} = 0 \text{ if } t < T_c^{build} \quad \forall c \in \Omega^{C^g}, t \in \Omega^T, s \in \Omega^S \quad (6)$$

$$\sum_{c \in \Omega^{C^g}} \sum_{t \in \Omega^T} \sum_{s \in \Omega^S} \frac{C_{ct}^{inv} \chi_{ct}}{(1+d)^{t-1}} \leq C_t^{inv,max} \quad \forall t \in \Omega^T \quad (7)$$

$$\alpha_{k(t-1)s} \leq \alpha_{kts} \quad \forall k \in \Omega^{C^l}, t \in \Omega^T, t \geq 2, s \in \Omega^S \quad (8)$$

$$\sum_{k \in \Omega^{C^l}} \sum_{s \in \Omega^S} \alpha_{kts} \leq \alpha_{kts}^{max} \quad \forall t \in \Omega^T \quad (9)$$

$$\alpha_{kts} = 0 \text{ if } t < T_k^{build} \quad \forall k \in \Omega^{C^l}, t \in \Omega^T, s \in \Omega^S \quad (10)$$

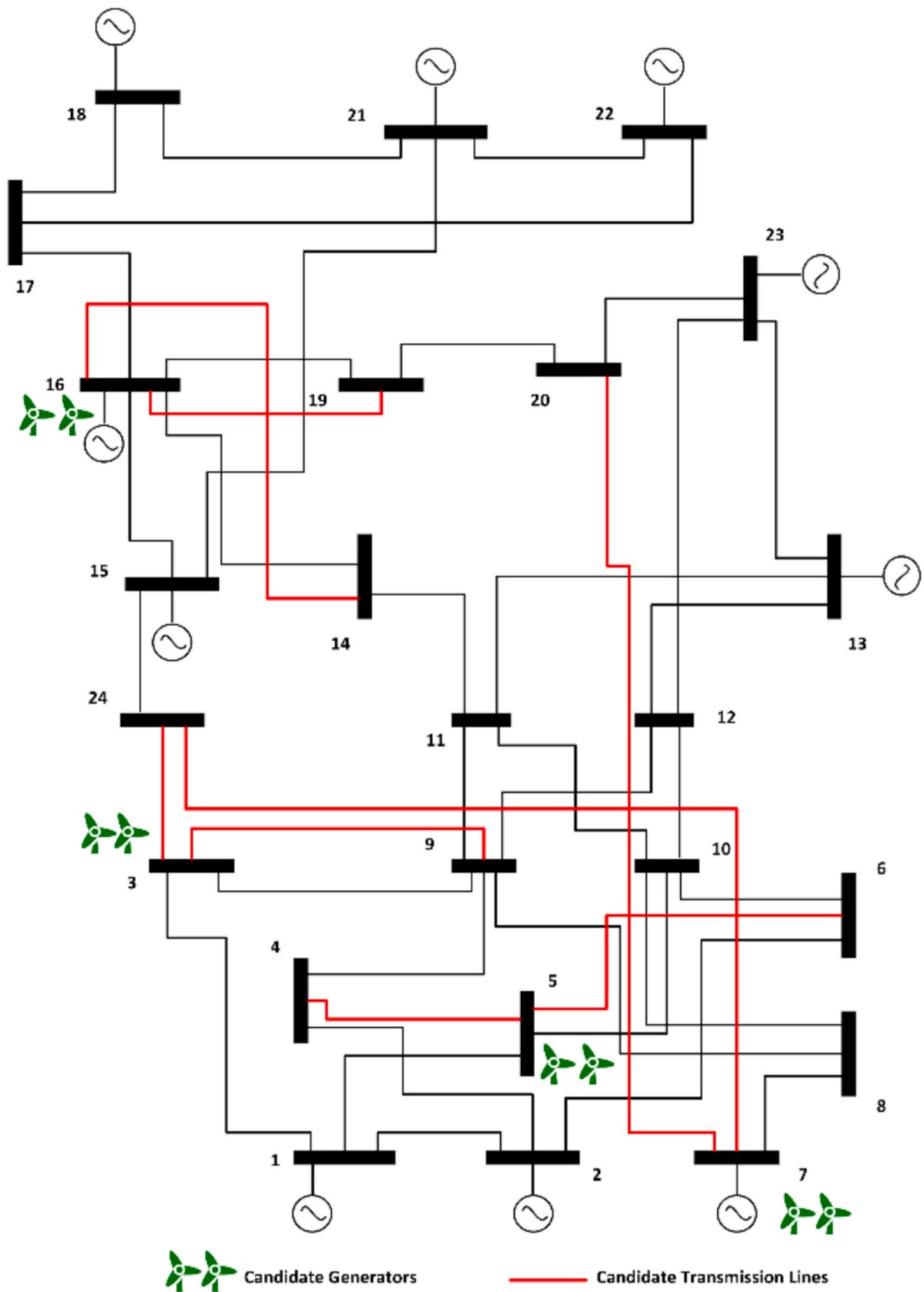

Fig. 2. Modified IEEE 24 bus system.

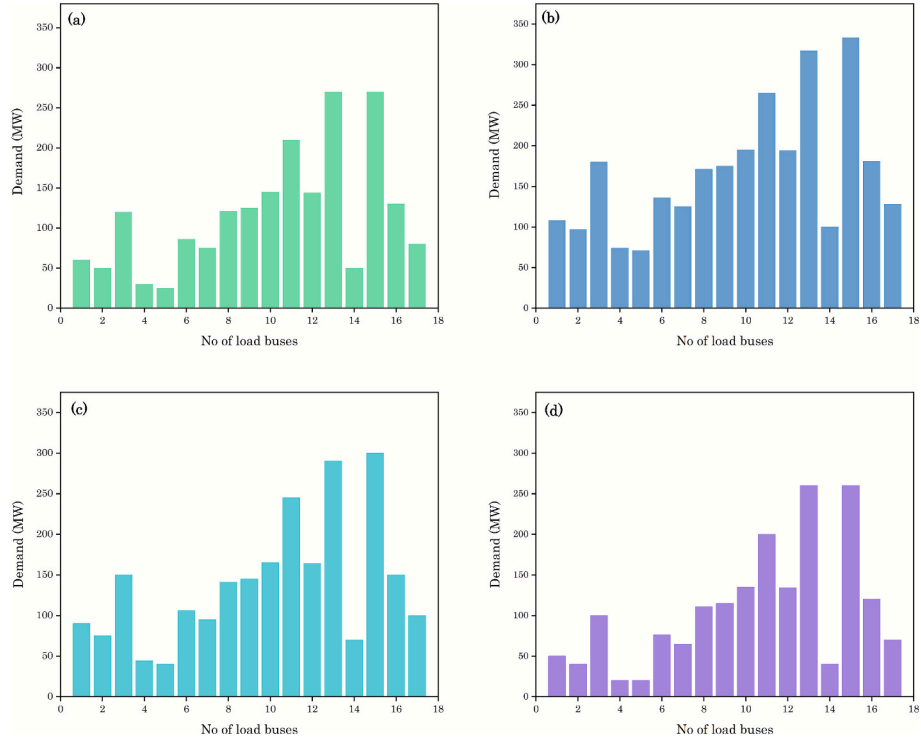

Fig. 3. Demand at load bus in IEEE 24-bus system (a) Scenario 1 (b) Scenario 2 (c) Scenario 3 (d) Scenario 4.

Table 2  
Load block summary.

No of block	Load Level [%]	Duration per year [h]	LC Cost [\$/MW]	LS Cost [\$/MW]
1	100	200	105	0
2	80	4200	0	70
3	60	4050	0	60
4	40	310	0	50

Table 3  
Total system cost of case 1.

Generator Investment cost [M\$]	Line Investment cost [M\$]	Line Operating cost [M\$]	Generator Operating cost [M\$]	Total Cost [M\$]
17.6	131.8	0.279	744.8	893.8

$$\sum_{t \in \Omega^T} \sum_{k \in \Omega^{C_1}} \frac{C_k^{inv} \alpha_{kts}}{(1+d)^{t-1}} \leq C_t^{inv,max} \quad \forall t \in \Omega^T, s \in \Omega^S \quad (11)$$

$$\sum_{n=t}^{\min(t+IRP_k-1, t_n)} [y_{kts} - (\alpha_{kts} - \alpha_{k(t-1)s})] \geq 0 \quad \forall t \in \Omega^T, k \in \Omega^{C_1}, s \in \Omega^S \quad (12)$$

Table 4  
Optimal existing power consumed in each year.

Existing Generator Power [GW]	Planning Period									
	1	2	3	4	5	6	7	8	9	10
LS 1	1.9	2.0	2.1	2.2	2.3	2.4	2.5	2.6	2.7	2.8
LS 2	2.8	2.9	3.1	3.2	3.3	3.3	3.3	3.2	3.3	3.3
LS 3	2.3	2.4	2.5	2.6	2.7	2.8	2.9	3.0	3.1	3.2
LS 4	1.8	1.9	2.0	2.1	2.2	2.2	2.3	2.4	2.5	2.6

$$\sum_{g \in \Omega^G} P_{gts}^g + \sum_{c \in \Omega^{C_2}} P_{cts}^c + \sum_{l \in \Omega^{L1}} P_{lts}^l - \sum_{l \in \Omega^{L2}} P_{lts}^l + \dots \quad (13)$$

$$\sum_{k \in \Omega^{C_1}} P_{kts}^k - \sum_{k \in \Omega^{C_2}} P_{kts}^k = \sum_{b \in \Omega^B} P_{bts}^d \quad \forall b, c, g, k, l, s, t$$

$$P_g^{min} \leq P_{gts}^g \leq P_g^{max} \quad \forall g, t, s \quad (14)$$

$$P_{cts}^{min} \chi_{cts} \leq P_{cts}^c \leq P_c^{max} \chi_{cts} \quad \forall c, t, s \quad (15)$$

$$P_{lts}^l = B_l (\delta_{lit} - \delta_{lct}) \quad \forall l, t, c, ij \in \Omega^B \quad (16)$$

$$-P_l^{max} \leq P_{lts}^l \leq P_l^{max} \quad \forall l \in \Omega^L, t \in \Omega^T, s \in \Omega^S \quad (17)$$

$$B_k^c (\delta_{kts} - \delta_{kts}) - P_{kts}^k + (1 - \alpha_{kts}) M_k \geq 0 \quad \forall k, t, s \quad (18)$$

$$B_k^c (\delta_{kts} - \delta_{kts}) - P_{kts}^k - (1 - \alpha_{kts}) M_k \leq 0 \quad \forall k, t, s \quad (19)$$

Table 5  
Candidate transmission lines built in optimal solution.

From bus	To bus	Year
7	20	2024
7	24	2026
14	16	2024
16	19	2028



**Table 8**  
Transmission line built in each NEP.

Postage stamp			Per-power-flow		
From bus	To bus	Year	From bus	To bus	Year
4	5	2029	3	24	2025
5	6	2024	5	6	2024
7	24	2024	7	20	2024
			7	24	2024
Per-power-flow-distance					
From bus	To bus	Year			
3	24	2024			
5	6	2024			
7	20	2024			
7	24	2024			

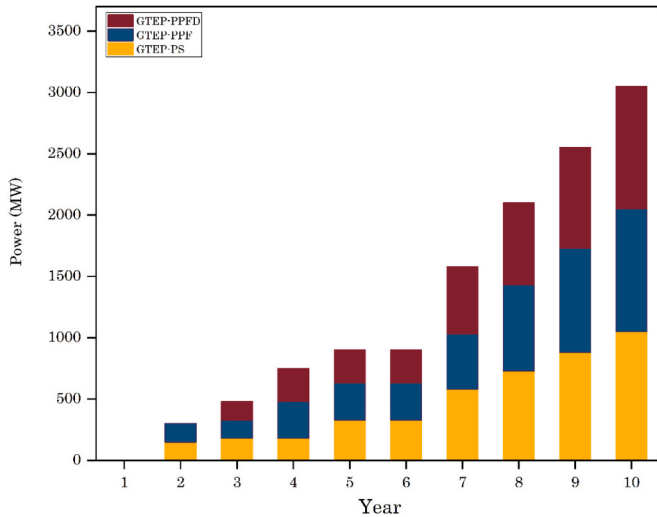

**Fig. 5.** Candidate generating units' power consumption in each payment scheme over a 10-year planning period.

$$-\alpha_{kts} P_k^{k,\max} \leq P_{kts}^k \leq \alpha_{kts} P_k^{k,\max} \quad \forall k, t, s \quad (20)$$

$$\delta_b^{\min} \leq \delta_{bts} \leq \delta_b^{\max} \quad \forall b, t, s \quad (21)$$

The aim of objective function (3) is to minimize the total cost of the system. The first term (1) in total cost corresponds to investment cost for new generating units along with the operation cost. The second term (2) corresponds to new transmission lines along with their operational cost. The result of this model would outline bus location, time, and number of the candidate units or lines to be built in the planning period to meet the forecasted demand. Binary variable  $\chi_{cts}$  represent new generating unit  $c$  constructed at time  $t$  in scenario  $s$ . The addition of new transmission line  $k$  in time  $t$  in scenario  $s$  is represented by binary variable  $\alpha_{kts}$ . Constraint (4) prevent replication of generating unit investment, which is  $\chi_{cts} = 1$  and will remain 1 throughout the planning time. Constraints (5) and (6) laid a bound on the number and time of generating units to be constructed in planning time. Constraint (7) indicated about maximum capital investment for new generating unit in the planned year. Constraint (8) represents one time investment of transmission lines to avoid repetition. Constraints (9)(10) include candidate transmission lines number and time for construction. The maximum capital investment for a new transmission line in a planning year is discussed in (11). Constraint (12) showed status of invested return period of invested lines, it ensured that  $y_{kts} = 1$ , when the IRP is not completed yet. Supply and demand balance are satisfied by constraint (13), while the existing and candidate generators power limit are restricted to their range by constraints (14) and (15). The power through existing lines is given in constraint (16) and their limit is restricted in constraint (17). The active

power of candidate transmission lines is bounded in constraints (18)(19) and (20). Limit on voltage angles at bus is given in constraint (21).

#### Base model with postage stamp scheme

Postage stamp refers to a simple type of network payment scheme, in which regardless of energy flow in a line, the consumer is charged with a fixed payment. The cost is charged per line to recover the investment cost of newly constructed transmission lines. The model with line recovery cost is formulated below;

$$\begin{aligned} \text{Minimize} \sum_{t \in \Omega^T} \frac{1}{(1+d)^{t-1}} & \left[ \sum_{c \in \Omega^G, s \in \Omega^S} C_c^{inv} \chi_{cts} + \sum_{g \in \Omega^G} C_g^{op} P_{gts}^g + C_c^{op} P_{cts}^c \right] \dots \\ & + \left[ \sum_{l \in \Omega^L, s \in \Omega^S} \vartheta \phi_{lts} + \sum_{k \in \Omega^L} \vartheta \phi_{kts} \right] \end{aligned} \quad (22)$$

Subject to:

$$\sum_{t \in \Omega^T} \frac{1}{(1+d)^{t-1}} \left[ \sum_{l \in \Omega^L, s \in \Omega^S} \vartheta \phi_{lts} + \sum_{k \in \Omega^L} \vartheta \phi_{kts} \right] \geq \sum_{t \in \Omega^T} \frac{1}{(1+d)^{t-1}} \quad (23)$$

$$\left[ \sum_{k \in \Omega^L, s \in \Omega^S} C_k^{inv} y_{kts} + \sum_{l \in \Omega^L} C_l^{op} + C_k^{op} \alpha_{kts} \right]$$

$$|P_{k,t,s}^k| = \phi_{kts} P_{k,t,s}^{k,\max} \dots |P_{l,t,s}^l| = \phi_{lts} P_{l,t,s}^{l,\max} \quad (24)$$

The objective function of postage stamp scheme is given by (22), which has two terms. The first term corresponds to the generation cost and second term to line recovery cost for postage stamp. Constraint (23) establishes that the line payment of postage stamp scheme must be equal or greater to the transmission line investment and operational costs. Both the terms would be zero in case of non-construction of transmission line. This scheme would also cover the operational cost if the payback period of the line is completed.

It should be noticed that a postage stamp is a fixed cost scheme for using transmission line and charges are paid by consumer according to per hour usage. Our model is based on annual periods, so we consider a small portion of usage hours in a year as shown by binary variable. The number of hours for line usage at time  $t$ , in scenario  $s$  is calculated in constraint (24).

#### Base model with Per-Power-Flow scheme

Per-power-flow, a suitable network payment model which charge payment from customers according to the amount of power flowing in transmission lines. This scheme formulation with base case is given below;

$$\begin{aligned} \text{Minimize} \sum_{t \in \Omega^T} \frac{1}{(1+d)^{t-1}} & \left[ \sum_{c \in \Omega^G, s \in \Omega^S} C_c^{inv} \chi_{cts} + \sum_{g \in \Omega^G} C_g^{op} P_{gts}^g + C_c^{op} P_{cts}^c \right] \dots \\ & + \left[ \sum_{l \in \Omega^L, s \in \Omega^S} \nu |P_{lts}^l| + \sum_{k \in \Omega^L} \nu |P_{kts}^k| \right] \end{aligned} \quad (25)$$

Subject to:

$$\begin{aligned} \sum_{t \in \Omega^T} \frac{1}{(1+d)^{t-1}} & \left[ \sum_{l \in \Omega^L, s \in \Omega^S} \nu |P_{lts}^l| + \sum_{k \in \Omega^L} \nu |P_{kts}^k| \right] \\ & \geq \sum_{t \in \Omega^T} \frac{1}{(1+d)^{t-1}} \left[ \sum_{k \in \Omega^L, s \in \Omega^S} C_k^{inv} y_{kts} + \sum_{l \in \Omega^L} C_l^{op} + C_k^{op} \alpha_{kts} \right] \end{aligned} \quad (26)$$

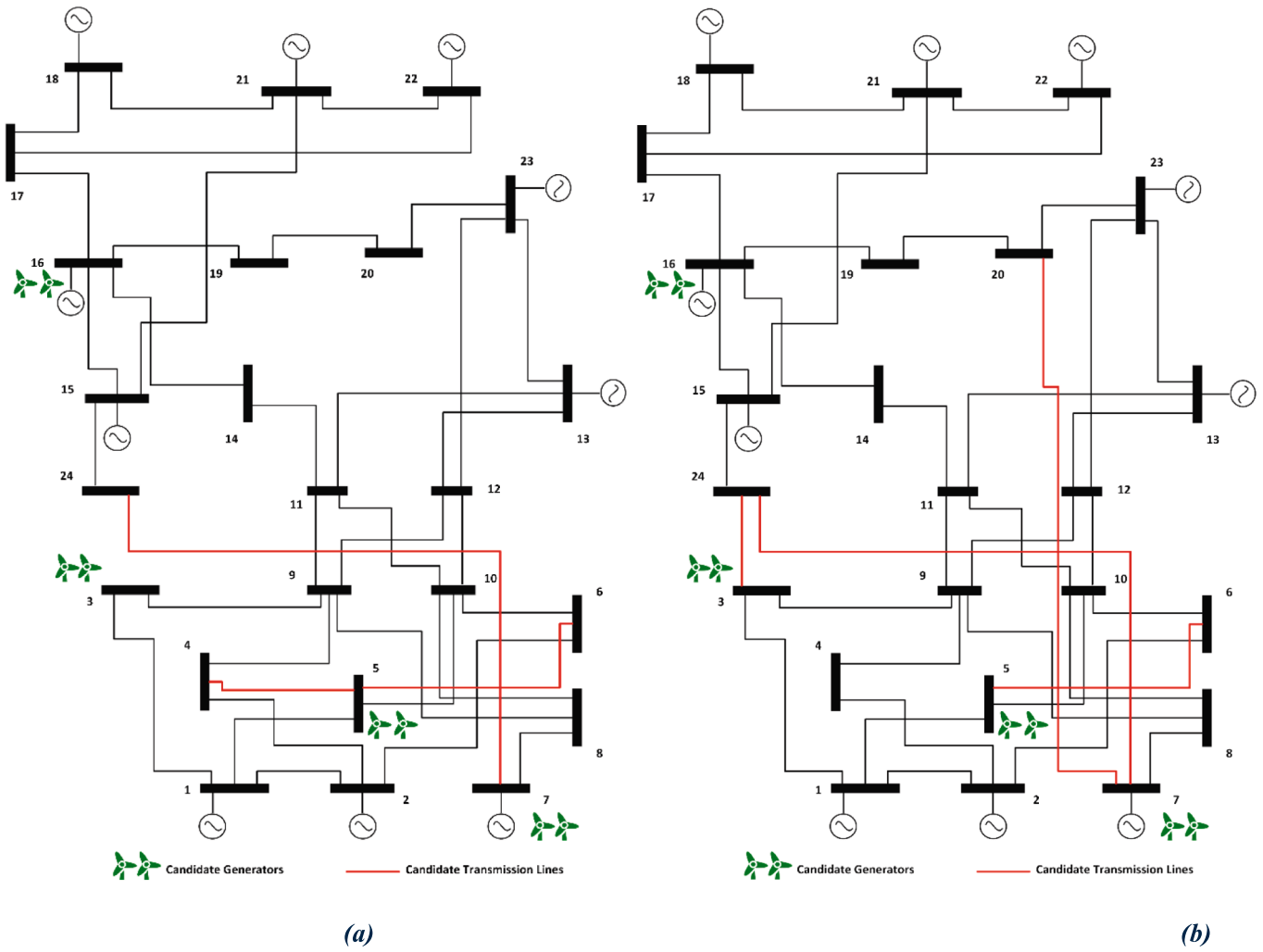

Fig. 6. Candidate lines and generators construction in each payment scheme (a) PS, and (b) PPF & PPF.

Table 9  
Total system cost in case 3.

Generator investment cost [M\$]	Line investment cost [M\$]	Line operating cost [M\$]	Generator operating cost [M\$]	LC cost [M \$]	LS cost [M \$]	Total cost [M\$]
26.6	107.15	0.262	722.6	0.01	0.48	855

Table 10  
Optimal power consumed in each load block over the planning period in case 3.

Load block [GW]	Planning Period									
	1	2	3	4	5	6	7	8	9	10
1	2.2	2.3	2.4	2.5	2.3	2.4	2.5	2.6	2.8	2.9
2	2.1	2.1	2.2	2.3	2.3	2.1	2.1	2.2	2.3	2.4
3	1.5	1.6	1.6	1.6	1.7	1.7	1.7	1.8	1.8	1.8
4	1.0	1.0	1.0	1.0	1.0	1.0	1.0	1.0	1.0	1.0

As mentioned in the postage stamp scheme, the objective function (25) is comprised of two terms. The first term accounts for new generators investment and operational cost, while the second term for recovery cost related to line usage in this scheme. Constraint (26) satisfies that the line payment cost under this scheme should be greater or equal to the new transmission line investment and their operational cost.

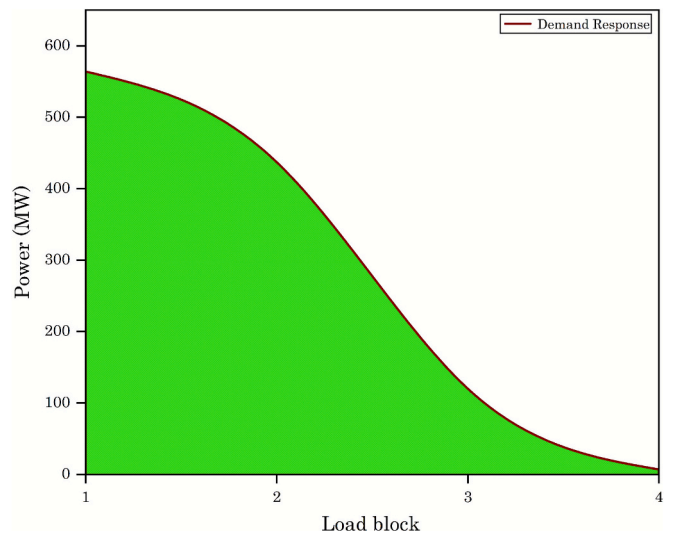

Fig. 7. Load curtailment and shifting in the load block of the DR plan in year 1.

Base model with Per-Power-Flow-Distance scheme

Per-power-flow-distance is the most diversified network payment

**Table 11**  
Candidate transmission lines built in optimal solution.

From bus	To bus	Year
7	20	2029
7	24	2025
14	16	2026

scheme, which charges the customer according to the amount of power flow and the length of the transmission line. The transmission line payment depends on its length. The greater the length, the greater the payment and vice versa. The scheme formulation, based on the base case, is outlined below.

$$\text{Minimize} \sum_{t \in \Omega^T} \frac{1}{(1+d)^{t-1}} \left[ \sum_{c \in \Omega^{cs} s \in \Omega^S} C_c^{inv} \chi_{cts} + \sum_{g \in \Omega^G} C_g^{op} P_{gts}^g + C_c^{op} P_{cts}^c \right] \dots + \left[ \sum_{l \in \Omega^L s \in \Omega^S} \gamma \sigma_{lts} |P_{lts}^l| + \sum_{k \in \Omega^{cl}} \gamma \sigma_{kts} |P_{kts}^k| \right] \quad (27)$$

Subject to:

$$\sum_{t \in \Omega^T} \frac{1}{(1+d)^{t-1}} \left[ \sum_{l \in \Omega^L s \in \Omega^S} \gamma \sigma_{lts} |P_{lts}^l| + \sum_{k \in \Omega^{cl}} \gamma \sigma_{kts} |P_{kts}^k| \right] \geq \sum_{t \in \Omega^T} \frac{1}{(1+d)^{t-1}} \left[ \sum_{k \in \Omega^{cl} s \in \Omega^S} C_k^{inv} \chi_{kts} + \sum_{l \in \Omega^L} C_l^{op} + C_k^{op} \alpha_{kts} \right] \quad (28)$$

The objective function (27) is the same as the per-power-flow scheme mentioned above but only differs in that the transmission line length shown by constraint (28) is the line recovery cost for the Per-power-flow-distance scheme and is the same as mentioned in (23) and (26).

#### Base model with DR

DR is implemented with a GTEP model to reshape the load profile for improved efficiency. DR response is classified into two types: price-based DR and incentive-based DR. Our model considers incentive-based DR, as peak load occurs only for a specific period, and acts as a supplement to meet peak demand, reduce expansion planning investment costs, and improve network reliability. The load block table mentioned above indicates that the peak load is curtailed in load block 1 and then shifted to other load blocks, as per the optimal solution. This DR plan would help smooth the load block curve, thereby enhancing system reliability. The model formulations for both DR curtailment and DR shifting are presented below.

$$DR^{curtail} = \sum_{bts} \theta_{bts} \Omega_{bts} \quad \forall b \in B, t \in T, s \in S \quad (29)$$

$$DR^{shift} = \sum_{bts} \tau_{bts} \zeta_{bts} \quad \forall b \in B, t \in T, s \in S \quad (30)$$

$$\text{Minimize} [C + DR^{curtail} + DR^{shift}] \quad (31)$$

Subject to:

$$\sum_{g \in \Omega^G} P_{gts}^g + \sum_{c \in \Omega^{cs}} P_{cts}^c + \sum_{l \in \Omega^{L1}} P_{lts}^l - \sum_{l \in \Omega^{L2}} P_{lts}^l + \dots + \sum_{k \in \Omega^{cl1}} P_{kts}^k - \sum_{k \in \Omega^{cl2}} P_{kts}^k = \sum_{b \in \Omega^B} P_{bts}^d - \sum_{bts} (\Omega_{bts} + \zeta_{bts}) \quad \forall b, c, g, k, l, s, t \quad (32)$$

$$0 \leq \zeta_{bts} \leq \infty_{bts} P_{bts}^d, \quad s = 1 \\ -\infty_{bts} P_{bts}^d \leq \zeta_{bts} \leq 0, \quad s = 0 \quad (33)$$

$$0 \leq \Omega_{bts} \leq \infty_{bts} P_{bts}^d, \quad s = 1 \\ \Omega_{bts} = 0, \quad s = 0 \quad (34)$$

In (29), the load curtailment, along with the cost per load curtailment in a particular year and scenario, is modelled. Similarly, (30) describes the load shifting in addition to the cost per load shifting. The overall objective function (31) is formulated to minimise total system cost by incorporating load curtailment cost and load shifting compensation cost.

The supply and demand in (13) are balanced by adding curtailed and shifted power as mentioned in constraint (31). Constraint (34) describes the load curtailment condition and will only occur in the load block scenario 1. Similarly, the load-shifting condition that will happen in the remaining three load block scenarios to fill the gap is mentioned in constraint (33).

#### Base model with DR and network payment schemes

$$\text{Minimize} \sum_{t \in \Omega^T} \frac{1}{(1+d)^{t-1}} \left[ \sum_{l \in \Omega^L s \in \Omega^S} \vartheta \phi_{lts} + \sum_{k \in \Omega^{cl}} \vartheta \phi_{kts} \right] + [C + DR^{curtail} + DR^{shift}] \quad (35)$$

$$\text{Minimize} \sum_{t \in \Omega^T} \frac{1}{(1+d)^{t-1}} \left[ \sum_{l \in \Omega^L s \in \Omega^S} \nu |P_{lts}^l| + \sum_{k \in \Omega^{cl}} \nu |P_{kts}^k| \right] + [C + DR^{curtail} + DR^{shift}] \quad (36)$$

$$\text{Minimize} \sum_{t \in \Omega^T} \frac{1}{(1+d)^{t-1}} \left[ \sum_{l \in \Omega^L s \in \Omega^S} \gamma \sigma_{lts} |P_{lts}^l| + \sum_{k \in \Omega^{cl}} \gamma \sigma_{kts} |P_{kts}^k| \right] + [C + DR^{curtail} + DR^{shift}] \quad (37)$$

DR having GTEP is modelled with three network payment schemes, such as postage stamp, per-power-flow, and per-power-flow-distance. The objective function (35) describes the combination of GTEP with DR and postage stamp scheme in a planning model to minimise the total cost of the power network. Similarly, the objective functions (36) and (37) represent the per-power-flow and per-power-flow-distance schemes to be modelled with GTEP and DR, respectively, to minimise total system cost.

Constraints of this proposed model are already discussed in the above sections such as for base case (4) to (21); NPS (23),(24),(26),(28); and DR (32) to (34). All these constraints are combined with the above objective functions to form a coordinated generation and transmission expansion model, incorporating a DR plan and network payment schemes.

#### Test system data

The proposed case studies are tested on a modified IEEE 24-bus system for detailed analysis. The IEEE 24-bus system comprises 24 buses and 34 transmission lines, with 10 buses utilized by 9 different conventional generation units, each having a maximum installed capacity of 3405 MW [31]. Four buses 3,5,7,16 have been used for 8 candidate wind farm generation units in our model as shown in Fig. 2. The capacity of transmission lines is reduced to inject congestion into the system. There is a fixed capacity of 175 MW at lines 1 to 6, 8, 10, 12, and 13. 350 MW at line 9, while the remaining lines have a 400 MW capacity. The operational cost for each type of conventional generating unit is mentioned in [25]. Four scenarios are characterized based on demand data, as shown in Fig. 3. These four scenarios define peak load levels for four seasons. During a year, the load at scenario 4 corresponds to the lowest peak load, and scenario 2 has the highest load consumption

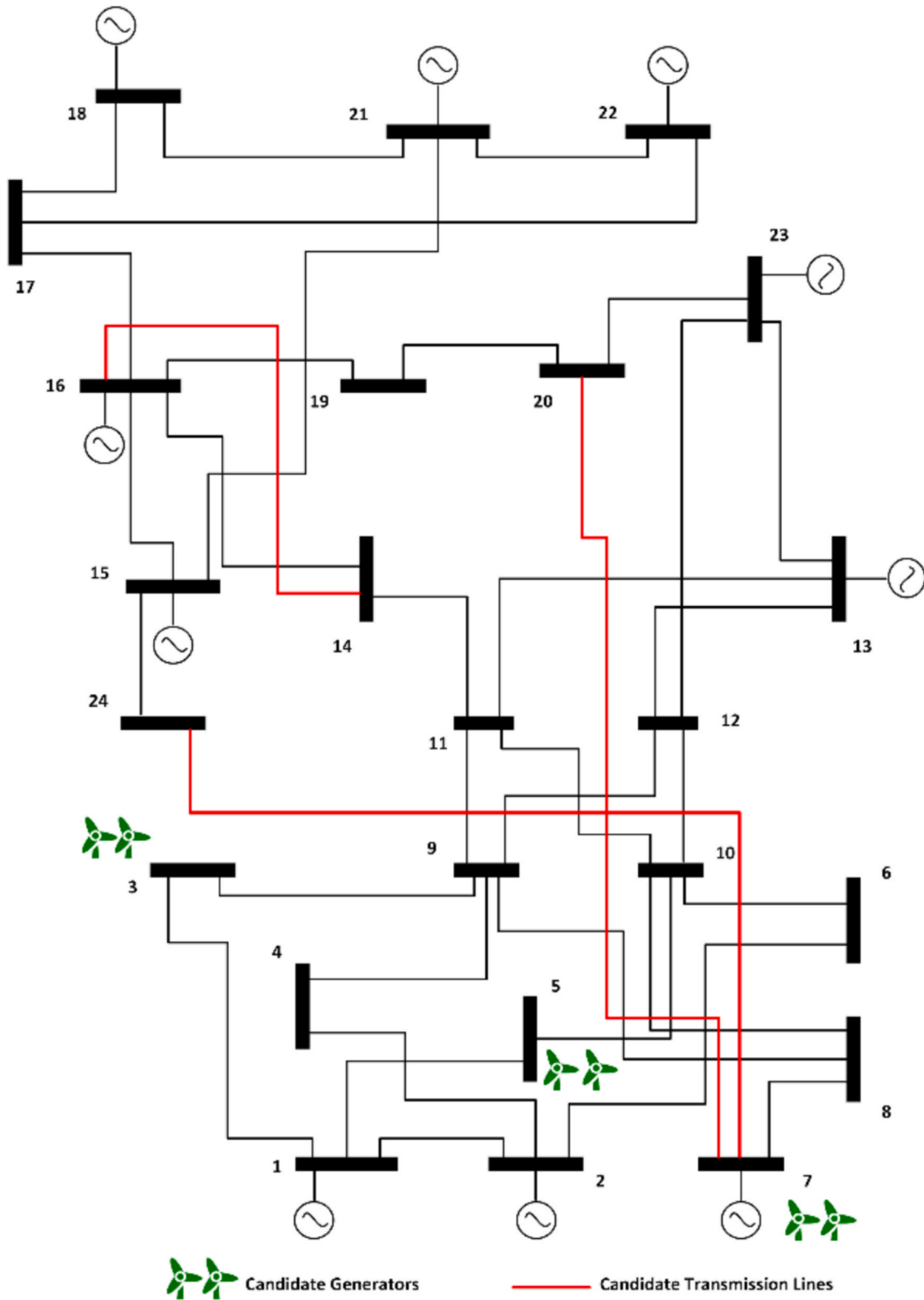

Fig. 8. Candidate lines and generators construction in case 3.

during the year. A 5% annual load growth is considered for a 10-year planning period in the model. Similarly, a discount rate of 10% with an internal rate of return (IRR) of 4% is used in the proposed model.

*DR data*

The load block curve is used in place of the typical load duration curve in DR analysis within our model. The load block curve is a descending order curve with peak load at the start and gradually decreasing till the consumption period. The load level percentage for

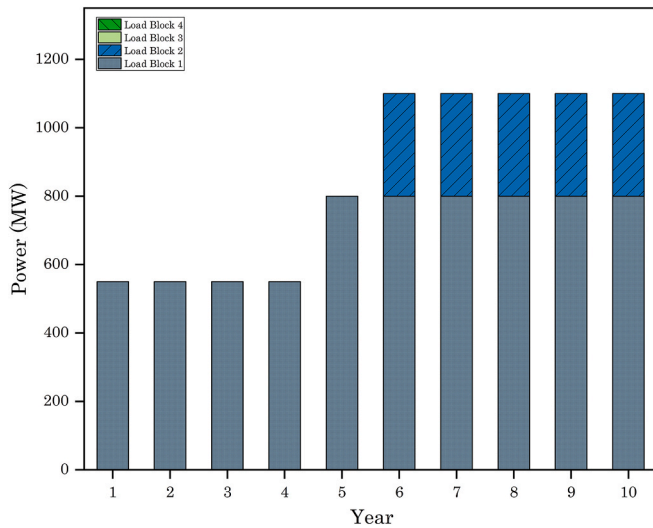

Fig. 9. Candidate units' power consumption in each load block (LB) in the 10-year planning period.

each load block, consumption duration, and cost of load curtailment and shifting are summarized in Table 2.

**Numerical simulations and results**

A modified IEEE 24-bus system was used to test the coordinated investment model. Four test cases are considered to analyze the economic benefits of the proposed model, such as;

- Case 1: An expansion planning model with generation and transmission (GTEP)
- Case 2: GTEP along with three different network payment schemes (GTEP + NEP)
- Case 3: GTEP along with DR (GTEP + DR)
- Case 4: A combined sensitivity analysis of (GTEP + DR + NEP)

Case 1 is the base case in which only generation and transmission are considered for expansion planning in a planning horizon. In Case 2, the economic impact of network payment schemes on GTEP model is analysed. Case 3 determines the effects of DR on the GTEP model when analysed in the same planning horizon. Case 4 shows a coordinated sensitivity analysis for GTEP, DR and NEP when tested in a forecasted scenario. Optimisation programming language (OPL) is used for all case studies modelling, and CPLEX version 12.1 is used as the solver. An Intel Core i3 4th-generation laptop, along with 4 GB of RAM, is used to perform all simulations.

**Case 1**

A basic planner model for generation and transmission expansion (GTEP) is analyzed in this case for a 10-year planning period. The model solely considers generation expansion through the addition of candidate wind farms, and transmission expansion is driven by load growth over the planning horizon. Generation and transmission investment decisions are jointly optimized to minimize the total system cost while satisfying

**Table 12**

Total cost for each NPS in case 4.

NPS	Line investment cost [M\$]	Generator investment cost [M\$]	Generator operating cost [M\$]	Network payment [M\$]	LC cost [M\$]	LS cost [M\$]	Total cost [M\$]
PS	148.32	26.7	746.2	319.7	0.0215	0.48	1092.1
PPF	217.5	32.1	736.3	239.7	0.0215	0.48	1007.7
PPFD	179.5	35.7	754.1	31.71	0.0215	0.48	821.1

operational and reliability constraints. This base GTEP formulation provides a reference framework for subsequent case studies. The total system cost for the GTEP model is shown in Table 3. The total amount of existing power consumed during the four load scenarios in the planning horizon is described in Table 4. Table 5 and Fig. 4 show the number of candidate transmission lines built in the optimal solution of the GTEP model.

**Case 2**

Three distinct types of network payment schemes, i.e. postage stamp (PS), per-power-flow (PPF), and per-power-flow-distance (PPFD), are combined with the base case in case 2. Table 6 shows tariff parameters for these three payment schemes. The optimal tariff calculation is a challenging task and beyond the scope of this current study; however, we calculated the tariff values based on the minimum objective function for the aforementioned payment schemes after conducting several simulations. The total system cost for each payment scheme, along with the cost recovery for each constructed line, is summarised in Table 7. Table 8 shows the number of candidate transmission lines built in each payment scheme. Figs. 5 and 6 describe the construction of new generating units and their power consumption for each payment scheme in an optimal solution. It shows that new generating units are constructed only in load scenario 2, which is due to the peak demand as compared to other scenarios.

**Case 3**

In this case, DR is integrated with the base case model to increase profit for the user and reduce the cost of electricity. Two different DR options, i.e., load curtailment and load shifting, will determine the optimal DR plan in this case study. The optimal total system cost for the GTEP plus DR model is presented in Table 9, while the power generated by the existing generating unit in each load block over the planning period is listed in Table 10. The DR plan for year 1 is summarized in Fig. 7 and the number of lines built during a planned period is shown in Table 11 and Fig. 8. Similarly, the total number of candidate generation units' construction years and power consumption are shown in Fig. 9. The percentage for load reduced and shifted is the same, which is 20%.

**Table 13**

Transmission line built in each NPS in case 4.

Postage stamp			Per-power-flow		
From bus	To bus	Year	From bus	To bus	Year
4	5	2028	3	24	2024
5	6	2025	5	6	2024
7	20	2024	7	20	2024
7	24	2024	7	24	2024
14	16	2028	14	16	2024
Per-power-flow-distance					
From bus	To bus	Year			
3	9	2028			
5	4	2028			
5	6	2024			
7	20	2024			
14	16	2025			
16	19	2025			

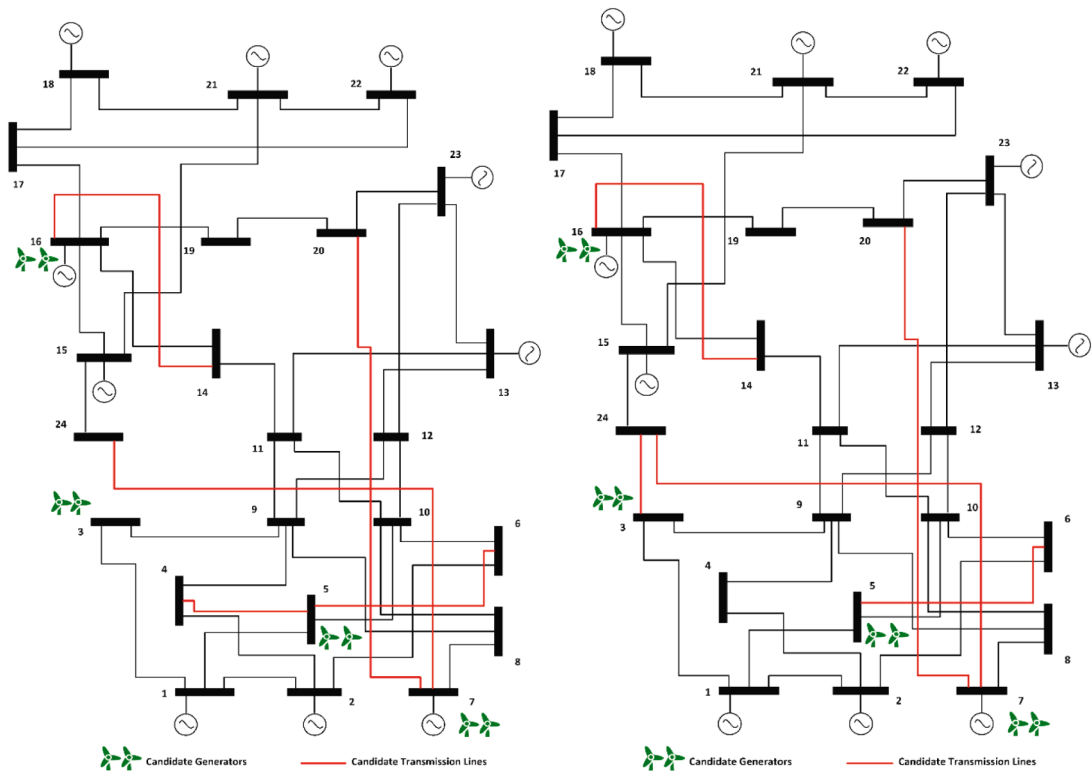

(a)

(b)

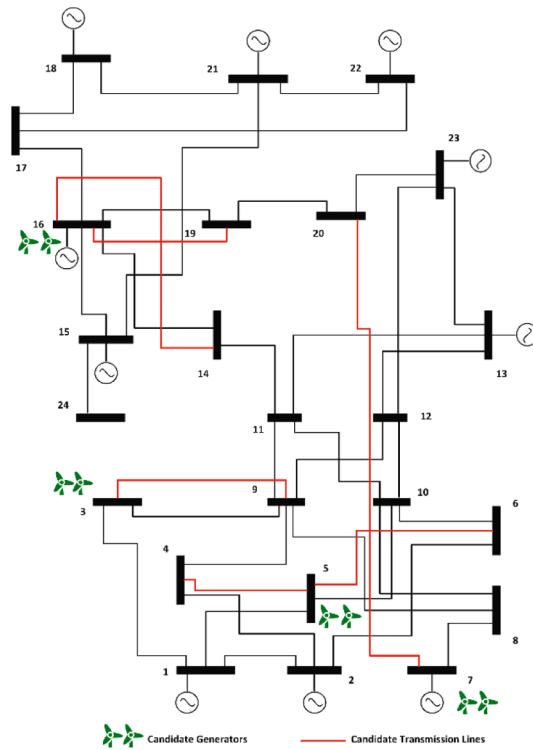

(c)

Fig. 10. Candidate lines and generators construction in case 4 (a) GTEP + PS + DR, (b) GTEP + PPF + DR, and (c) GTEP + PPF + DR.

**Table 14**  
Summary of total cost.

million \$	GTEP	GTEP-PS	GTEP-PPF	GTEP-PPFD	GTEP-DR	GTEP-DR-PS	GTEP-DR-PPF	GTEP-DR-PPFD
Total cost	946	1220	1120	859	855	1092	1007	821
Gen Invest cost	17.6	22.9	23.2	24.1	26.6	26.7	32.1	35.7
Line Invest cost	184	265	417	400	107	148	217	218
Line O&M cost	0.28	0.25	0.27	0.27	0.26	0.26	0.27	0.27
Gen O&M cost	744	778	764	789	722	746	736	754
NP	–	419	332	45	–	319	239	31
LC cost	–	–	–	–	0.02	0.02	0.02	0.02
LS cost	–	–	–	–	0.48	0.48	0.48	0.48
Cost Saving (%)	–	–	8.2	29.6	29.9	10.5	17.5	32.7

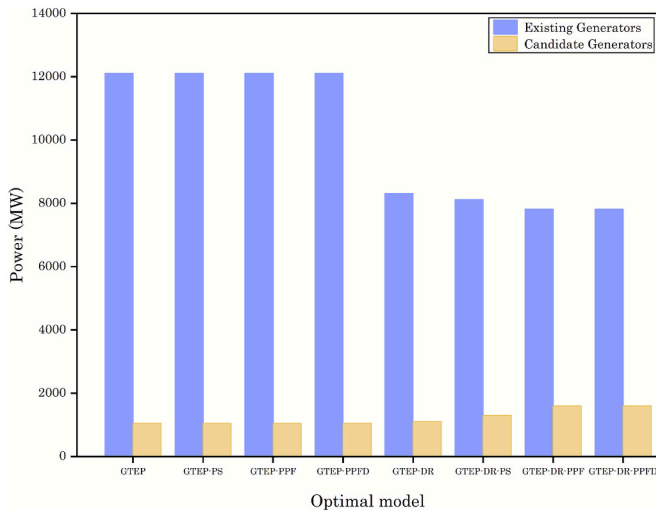

**Fig. 11.** Existing and Candidate generators for power generation in each case study.

**Table 15**  
Summary of transmission line constructed in each optimal model.

Optimal Model	No. of lines	Year
GTEP	4	2024, 2024, 2026, 2028
GTEP-PS	3	2024, 2024, 2029
GTEP-PPF	4	2024, 2024, 2024, 2025
GTEP-PPFD	4	2024, 2024, 2024, 2024
GTEP-DR	3	2025, 2026, 2029
GTEP-DR-PS	5	2024,2024, 2025, 2028, 2028
GTEP-DR-PPF	5	2024,2024, 2024, 2024, 2024
GTEP-DR-PPFD	6	2024,2024,2025, 2025, 2028, 2028

**Case 4**

DR problem along with network payment scheme in an expansion and planning environment has not been studied yet. This case study comprehensively analyses the research gap by modelling DR with NPS and GTEP. Economic analysis in the form of total cost is summarized in Table 12. Table 13 and Fig. 10 correspond to the number of candidate lines constructed during the planning time. The parameters for the DR model were kept the same as in case 3. Therefore, no significant changes occurred in load curtailment and shifting calculations.

**Discussion**

Results of the above four case studies are examined and discussed in this section. In each case study, an optimal solution is achieved based on the demand scenarios stated above, and the impact of this optimal solution on system performance will be discussed later in this section.

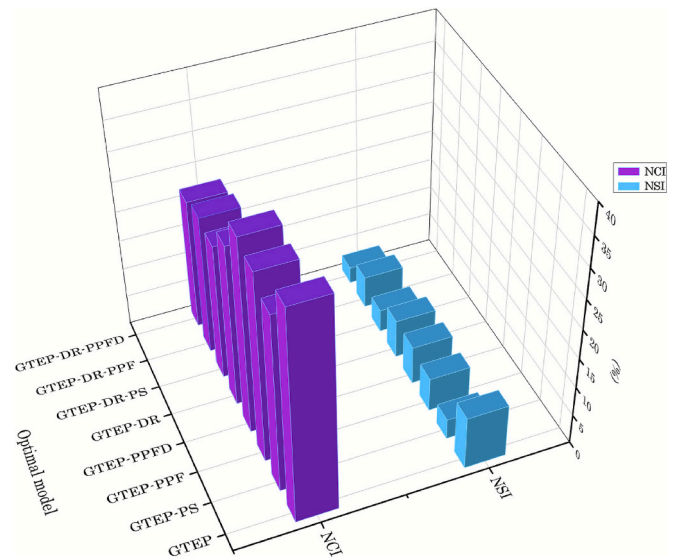

**Fig. 12.** Existing and Candidate generators for power generation in each case study.

Three main parameters, including total cost, power capacity, investment decision, and reliability indexes (NSI & NCI) of each case study, will be compared to achieve a suitable solution.

**Total cost**

The total cost of the optimal solution for each case study is compared in Table 14. The table shows that the base model (GTEP) has the least total cost, line investment cost, and generator operational cost. This is mainly due to the absence of a line recovery cost guarantee in the planning and expansion model. Therefore, it allows for a minimum investment and ultimately reduces operational costs. The highest total cost is obtained in the GTEP-PS model, and the lowest in the GTEP-DR-PPFD model. The PS payment scheme has a fixed tariff, which increases transmission line investment costs, whereas the PPF payment scheme only charges for the amount of power transmitted across each line and its distance.

The lowest generator operational cost and transmission line investment cost are obtained in the GTEP-DR model. It is due to the DR plan, which reduces peak load to smooth the load block curve and minimise the burden on existing generation units. It also delays investment decisions for new generating units and transmission lines in the power system. The highest total cost savings of 32.7% and 29.9% are achieved by GTEP-DR-PPFD and GTEP-DR, respectively, in comparison with GTEP-PS. In summary, the results suggest that the GTEP model with more discrimination by planning technique has a lower total cost than the GTEP model with no planning technique.

### Power capacity and investment decision

The power delivered by existing and candidate generating units in each optimal model for all scenarios in the final planning year is compared in Fig. 11. The results show that the power capacity of the existing line decreased by 31.3% when the DR plan is incorporated in the GTEP model, and a further decline of 2% occurs upon the GTEP-DR-NPS model. The power capacity of candidate generating units increases by 34.3% when a combined formulation of GTEP, DR, and NPS is performed. Overall, the combined study of DR and NPS with GTEP provides an optimal solution to reduce existing power capacity and exploit more power from candidate generating units. The investment decision for the new transmission line in each optimal model is compared and summarised in Table 15. The results indicate that a significant number of transmission lines are constructed in the NPS model with DR and GTEP, primarily due to the inclusion of NPS with line cost recovery in the model's objective function, which affects the system's operation. The number of transmission lines constructed in the early period of the planning horizon is due to gathering an attractive investment return at the start of the planning period, such as in GTEP-DR-PPF.

### Network congestion and saturation index

The network congestion and saturation index is used to measure the performance of the proposed models for power systems. The network congestion index is defined as the power flow expected in a line divided by the total power capacity of the transmission line (38). NCI is usually related to transmission line usage over the planning period. The network saturation index is defined as the percentage of working transmission lines operating at their maximum power capacity during a planning period, as shown in Equation (39).

$$NCI = \frac{\sum_{k|ts} (|p_{lts}^l| + |p_{kts}^k|)}{\sum_{k|ts} (p_{kts}^{l,max} + p_{kts}^{k,max}) \alpha_{kts}} \quad (38)$$

$$NSI = \frac{\sum_{k|ts} x_{k|ts}}{\sum_{k|ts} \alpha_{kts}} \quad (39)$$

Table 12 summarises the NSI and NCI index for each model in a planning period. The GTEP model has the highest transmission line usage percentage (36.2%) and line saturation percentage (9%) among all proposed models. It is due to the trade-off between the generation operational cost and the new transmission line investment to minimise the objective function. The lowest percentages of both NCI and NSI (22.1%, 2.73%) are for the GTEP-DR-PPF model, which is due to the joint operation of the DR plan with NPS and GTEP to minimise generation cost for optimal electricity dispatch and also recover network expansion costs. The lowest NSI metric would help improve system reliability, as a smaller number of transmission lines would be saturated, and smooth power dispatch would occur upon changes in demand or during contingency periods (Fig. 12).

### Conclusion

This comprehensive research study presents a multi-year generation and transmission expansion planning model that considers potential high renewable energy penetration, network payment schemes, and DR. Three planning techniques, such as generation-transmission expansion, network payment schemes, and DR, are modelled in combination to achieve an optimal expansion planning model for a power network. Four case studies are proposed and validated on the modified IEEE 24-bus test system. The performance of these four case studies is assessed based on total system cost, power capacity and investment decision, as well as system reliability metrics. The optimal solution from four case studies suggests that implementing the per-power-flow-distance payment scheme and DR technique in the GTEP model is capable of minimizing

total system cost by up to 32.1% compared to other proposed models. It also implies that the GTEP-DR model has a lower DR incentive cost for consumers compared to new generation and transmission line construction costs, making it an alternative choice for central planners instead of generation and transmission expansion planning. The system reliability metrics, such as NCI and NSI for the GTEP model, are (36.2%, 9%). Moreover, the PPF and DR implementation in the GTEP model can significantly enhance system reliability by reducing network congestion and the saturation index (22.1%, 2.73%), allowing more candidate wind farms to integrate into the system and thereby improving system efficiency. In short, the GTEP model with more discrimination by planning technique would have a lower total system cost, enhanced system reliability, and better operational flexibility compared to the GTEP model with no discrimination by planning technique.

This study proposes a MILP-based model for generation and transmission expansion that incorporates network payment schemes and demand response to evaluate the key techno-economic metrics within the power network. However, it relies on a DCOPF, which overlooks the nonlinear voltage and reactive power behaviors captured by AC optimal power flow. Additionally, the model assumes a centralized investment approach managed by single investor and did not account for the decentralized decision-making typical in deregulated electricity markets.

Future work can expand this study in several ways. The GTEP model could be upgraded to include real-time pricing and DR features, enabling a more detailed analysis of short-term system flexibility. Applying the model to larger, more complex power grids would offer a more accurate depiction of transmission limitations. Incorporating uncertainty in renewable generation and load, along with emissions modelling, would further strengthen the research. Additionally, exploring meta-heuristic optimization methods as alternatives to MILP could increase diverse solutions for large-scale problems. Lastly, adding a Renewable Portfolio Standard (RPS) into the model would give a more comprehensive view of policy-driven investment pathways in modern power systems.

### CRedit authorship contribution statement

**Shehzad Ahmad:** Writing – original draft, Software, Methodology, Formal analysis, Data curation. **Muhammad Numan:** Writing – review & editing, Validation, Resources, Methodology, Conceptualization. **Izhar Us Salam:** Writing – review & editing, Investigation, Formal analysis, Conceptualization. **Muhammad Yousif:** Visualization, Validation, Supervision, Formal analysis.

### Declaration of competing interest

The authors declare that they have no known competing financial interests or personal relationships that could have appeared to influence the work reported in this paper.

### Data availability

Data will be made available on request.

### References

- [1] Balasubramanian S, Balachandra P. Effectiveness of demand response in achieving supply-demand matching in a renewables dominated electricity system: a modelling approach. *Renew Sustain Energy Rev* 2021;147. <https://doi.org/10.1016/j.rser.2021.111245>.
- [2] Bravo D, Sauma E, Contreras J, de la Torre S, Aguado JA, Pozo D. Impact of network payment schemes on transmission expansion planning with variable renewable generation. *Energy Econ* 2016;56:410–21. <https://doi.org/10.1016/j.eneco.2016.04.006>.
- [3] da Luz T, Moura P. Power generation expansion planning with complementarity between renewable sources and regions for 100% renewable energy systems. *Int Trans Electr Energy Syst* 2019;29:1–19. <https://doi.org/10.1002/2050-7038.2817>.

- [4] Nawaz U, Malik TN, Ashraf MM. Least-cost generation expansion planning using whale optimization algorithm incorporating emission reduction and renewable energy sources. *Int Trans Electr Energy Syst* 2020;30:1–21. <https://doi.org/10.1002/2050-7038.12238>.
- [5] Mahmoudi S, Mirhosseini Moghaddam M, Alizadeh B. Transmission and energy storage-expansion planning in the presence of correlated wind farms. *Int Trans Electr Energy Syst* 2019;29:1–14. <https://doi.org/10.1002/2050-7038.2840>.
- [6] Zhang L, Zhou Q, Gao Q, Cheng H, Zhang S. Multistage fuzzy-robust transmission network expansion planning under uncertainties. *Int Trans Electr Energy Syst* 2019;29:1–12. <https://doi.org/10.1002/2050-7038.12054>.
- [7] Numan M, Feng D, Abbas F, Rahman U, Wattoo WA. Impact assessment of a co-optimized dynamic line rating and transmission switching topology on network expansion planning. *Int Trans Electr Energy Syst* 2020;30:1–24. <https://doi.org/10.1002/2050-7038.12457>.
- [8] Niu W, Ge Y, Pan D, Ma L, Gao C, Transmission NK, et al. IEEE Sustainable Power and Energy Conference: Energy transition for Carbon Neutrality. *ISPEC* 2021;2021 (2021):1862–7. <https://doi.org/10.1109/ISPEC53008.2021.9735595>.
- [9] Morimoto Y, Iwamura K, Takamori H, Nakanishi Y. A Transmission Expansion Plan for Introducing Large-scale Renewable Energies. 2019 IEEE PES GTD Grand International Conference and Exposition Asia, GTD Asia 2019 2019:298–303. <https://doi.org/10.1109/GTDAsia.2019.8715974>.
- [10] Jenabi M, Fatemi Ghomi SMT, Smeers Y. Bi-level game approaches for coordination of generation and transmission expansion planning within a market environment. *IEEE Trans Power Syst* 2013;28:2639–50. <https://doi.org/10.1109/TPWRS.2012.2236110>.
- [11] Vronionis C, Tsalavoutis V, Tolis A. A Generation expansion Planning model for integrating high shares of renewable energy: a Meta-Model Assisted Evolutionary Algorithm approach. *Appl Energy* 2020;259:114085. <https://doi.org/10.1016/j.apenergy.2019.114085>.
- [12] Ma L, Wu Y, Lou S, Liang S, Liu M, Gao Y. Coordinated generation and transmission expansion planning with high proportion of renewable energy. 2020 IEEE 4th Conference on Energy Internet and Energy System Integration: Connecting the Grids Towards a Low-Carbon High-Efficiency Energy System, EI2 2020 2020: 1019–24. <https://doi.org/10.1109/EI250167.2020.9346900>.
- [13] Akbari E, Mousavi Shabestari SF, Pirouzi S, Jadidoleslam M. Network flexibility regulation by renewable energy hubs using flexibility pricing-based energy management. *Renew Energy* 2023;206:295–308. <https://doi.org/10.1016/j.renene.2023.02.050>.
- [14] Piltan G, Pirouzi S, Azarhooshang A, Rezaee Jordehi A, Paeizi A, Ghadamyari M. Storage-integrated virtual power plants for resiliency enhancement of smart distribution systems. *J Energy Storage* 2022;55. <https://doi.org/10.1016/j.est.2022.105563>.
- [15] Hu J, Xu X, Ma H, Yan Z. Distributionally Robust Co-optimization of Transmission Network expansion Planning and Penetration Level of Renewable Generation. *J Mod Power Syst Clean Energy* 2022;10:577–87. <https://doi.org/10.35833/MPCE.2021.000156>.
- [16] Bakkabulindi G, Ndayishimiye V, Miyingo EW. Optimal Grid expansion Planning in Power Systems with surplus Generation Capacity and Suppressed demand. *The Journal of Engineering* 2025; 2025. <https://doi.org/10.1049/tje2.70070>.
- [17] Chillogalli JE, Torres SP, Romero RR, Chumbi WE, Ergun H, Van Herterem D. AC Power Flow-based Co-Optimization for Integrated Generation and Transmission Network expansion Planning. *IEEE Power and Energy Society General Meeting, IEEE Computer Society* 2024. <https://doi.org/10.1109/PESGM51994.2024.10689001>.
- [18] Oboudi MH, Hamidpour H, Zadehbagheri M, Safae S, Pirouzi S. Reliability-constrained transmission expansion planning based on simultaneous forecasting method of loads and renewable generations. *Electr Eng* 2025;107:1141–61. <https://doi.org/10.1007/s00202-024-02556-9>.
- [19] Nwulu NI, Xia X. Multi-objective dynamic economic emission dispatch of electric power generation integrated with game theory based demand response programs. *Energy Convers Manag* 2015;89:963–74. <https://doi.org/10.1016/j.enconman.2014.11.001>.
- [20] Us Salam I, Yousif M, Numan M, Billah M. Addressing the Challenge of climate Change: the Role of Microgrids in Fostering a Sustainable Future - a Comprehensive Review. *Renewable Energy Focus* 2024;48. <https://doi.org/10.1016/j.ref.2024.100538>.
- [21] Li C, Dong ZY, Chen G, Luo F, Liu J. Flexible transmission expansion planning associated with large-scale wind farms integration considering demand response. *IET Gener Transm Distrib* 2015;9:2276–83. <https://doi.org/10.1049/iet-gtd.2015.0579>.
- [22] Ding Z, Hu Z, Wu J, Peng Q, Zhao H, Huang X. Optimal Transmission Expansion Planning Considering Demand Response Characteristics of Load Duration Curve. *Proceedings - 2022 7th Asia Conference on Power and Electrical Engineering, ACPEE 2022* 2022:40–4. <https://doi.org/10.1109/ACPEE53904.2022.9783835>.
- [23] Dini A, Hassankashi A, Pirouzi S, Lehtonen M, Arandian B, Baziar AA. A flexible-reliable operation optimization model of the networked energy hubs with distributed generations, energy storage systems and demand response. *Energy* 2022;239. <https://doi.org/10.1016/j.energy.2021.121923>.
- [24] Wang P, Du E, Zhang N, Xu X, Gao Y. Power system planning with high renewable energy penetration considering demand response. *Global Energy Interconnect* 2021;4:69–80. <https://doi.org/10.1016/j.gloi.2021.03.007>.
- [25] Gbadamosi SL, Nwulu NI. A multi-period composite generation and transmission expansion planning model incorporating renewable energy sources and demand response. *Sustainable Energy Technol Assess* 2020;39:100726. <https://doi.org/10.1016/j.seta.2020.100726>.
- [26] Malakoti-Moghaddam M, Askarzadeh A, Rashidinejad M. Transmission and generation expansion planning of energy hub by an improved genetic algorithm. *Energy Sources Part A* 2019;41:3112–26. <https://doi.org/10.1080/15567036.2019.1568640>.
- [27] Dalaliyan Miandoab P, Nazarian P, Moradlou M. Mathematical model for exploring the effect of demand response on transmission network expansion planning. *Electr Eng* 2024;106:5403–16. <https://doi.org/10.1007/s00202-024-02262-6>.
- [28] Moshari A, Ebrahimi A, Fotuhi-Firuzabad M. Short-Term Impacts of DR Programs on Reliability of Wind Integrated Power Systems considering Demand-Side Uncertainties. *IEEE Trans Power Syst* 2016;31:2481–90. <https://doi.org/10.1109/TPWRS.2015.2449778>.
- [29] Avar A, Sheikh-El-Eslami MK. A new benefit-based transmission cost allocation scheme based on capacity usage differentiation. *Electr Pow Syst Res* 2022;208: 107880. <https://doi.org/10.1016/j.epsr.2022.107880>.
- [30] Pop O, Kilyeni S, Barbulescu C, Paunescu D. Comparison of transmission cost allocation methods case study: DET WEST power system. *Proceedings of the Mediterranean Electrotechnical Conference - MELECON 2012:265–8*. <https://doi.org/10.1109/MELCON.2012.6196429>.
- [31] Orfanos GA, Tziassiou GT, Georgilakis PS, Hatzigiorgiou ND. Evaluation of transmission pricing methodologies for pool based electricity markets. 2011 IEEE PES Trondheim PowerTech: the Power of Technology for a Sustainable Society. *POWERTECH 2011;2011(218903):1–8*. <https://doi.org/10.1109/PTC.2011.6019255>.
- [32] Zhong H, Zhang G, Tan Z, Ruan G, Wang X. Hierarchical collaborative expansion planning for transmission and distribution networks considering transmission cost allocation. *Appl Energy* 2022;307:118147. <https://doi.org/10.1016/j.apenergy.2021.118147>.
- [33] Roustaei M, Sheikh-El-Eslami MK, Seifi H. Transmission cost allocation based on the users' benefits. *International Journal of Electrical Power and Energy Systems* 2014;61:547–52. <https://doi.org/10.1016/j.ijepes.2014.03.053>.
- [34] Jain G, Singh K, Palwalia DK. Transmission wheeling cost evaluation using MW-Mile methodology. 3rd Nirma University International Conference on Engineering, NUICONE 2012 2012:1–6. <https://doi.org/10.1109/NUICONE.2012.6493264>.
- [35] Alizadeh B, Jadid S. Reliability constrained coordination of generation and transmission expansion planning in power systems using mixed integer programming. *IET Gener Transm Distrib* 2011;5:948–60. <https://doi.org/10.1049/iet-gtd.2011.0122>.
- [36] Mortaz E, Valenzuela J. Evaluating the impact of renewable generation on transmission expansion planning. *Electr Pow Syst Res* 2019;169:35–44. <https://doi.org/10.1016/j.epsr.2018.12.007>.
- [37] Gu Y, McCalley JD, Ni M. Coordinating large-scale wind integration and transmission planning. *IEEE Trans Sustain Energy* 2012;3:652–9. <https://doi.org/10.1109/TSTE.2012.2204069>.
- [38] Zhang H, Vittal V, Heydt GT, Quintero J. A mixed-integer linear programming approach for multi-stage security-constrained transmission expansion planning. *IEEE Trans Power Syst* 2012;27:1125–33. <https://doi.org/10.1109/TPWRS.2011.2178000>.
- [39] Alvarez R, Rahmann C, Palma-Behnke R, Estévez PA. A novel meta-heuristic model for the multi-year transmission network expansion planning. *International Journal of Electrical Power and Energy Systems* 2019;107:523–37. <https://doi.org/10.1016/j.ijepes.2018.12.022>.
- [40] Jabarnejad M, Valenzuela J. Optimal investment plan for dynamic thermal rating using benders decomposition. *Eur J Oper Res* 2016;248:917–29. <https://doi.org/10.1016/j.ejor.2015.08.010>.
- [41] Emdadi K, Pirouzi S. Benders Decomposition-based Power Network expansion Planning according to Eco-Sizing of High-Voltage Direct-Current System, Power Transmission Cables and Renewable/Non-Renewable Generation units. *IET Renew Power Gener* 2025;19. <https://doi.org/10.1049/rpg2.70025>.
- [42] Wen J, Han X, Li J, Chen Y, Yi H, Lu C. Transmission network expansion planning considering uncertainties in loads and renewable energy resources. *CSEE J Power Energy Syst* 2015;1:78–85. <https://doi.org/10.17775/cseejpes.2015.00010>.