

Progress in the development of the ICRF system of DTT

Original

Progress in the development of the ICRF system of DTT / Ceccuzzi, S.; Aquilini, M.; Badodi, N.; Bonaventura, A.; Boncagni, L.; Camera, G.; Cardinali, A.; Casalegno, V.; Castaldo, C.; Cioffi, A.; Di Gironimo, G.; Di Paolo, F.; Ferraris, M.; Francalanza, V.; Galindo-Huertas, D. L.; Granucci, G.; Greco, S.; Grespan, F.; Lanzotti, F. G.; Liuzza, D.; Maddaluno, G.; Maccari, P.; Marinari, R.; Marino, F.; Mascali, D.; Mauro, G. S.; Milanesio, D.; Mirizzi, F.; Palmieri, A.; Pepato, A.; Petrolini, P.; Pidotella, A.; Piras, S.; Pollastrone, F.; Ponti, C.; Raspante, B.; Ravera, G. L.; Rocchi, A.; Romano, R.; Salvia, C.; Schettini, G.; Spinella, G.; Torrisi, G.; Tuccillo, A. A.; Tudisco, O.; Turganbaev, A.; Valletti, L.; Van Ester, D.; Vecchi, G.; Venneri, J.; Villone, F.; Wu, H. S. - In: FUSION ENGINEERING AND DESIGN. - ISSN 0920-3796. - 213: (2025). [10.1016/j.fusengdes.2025.114849]
This version is available at: [11583/2997505](https://doi.org/10.1016/j.fusengdes.2025.114849) since: 2025-02-13T17:00:20Z

Publisher:

Elsevier

Published

DOI:10.1016/j.fusengdes.2025.114849

Terms of use:

This article is made available under terms and conditions as specified in the corresponding bibliographic description in the repository

Publisher copyright

(Article begins on next page)

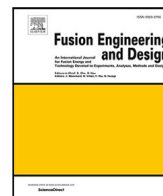

Progress in the development of the ICRF system of DTT

S. Ceccuzzi^{a,b}^{*}, on behalf of DTT ICH Contributors: M. Aquilini^a, N. Badodi^c, A. Bonaventura^d, L. Boncagni^a, G. Camera^{e,f,g}, A. Cardinali^h, V. Casalegnoⁱ, C. Castaldo^a, A. Cioffi^b, G. Di Gironimo^{b,e,f}, F. Di Paolo^j, M. Ferrarisⁱ, V. Francalanza^h, D.L. Galindo-Huertas^k, G. Granucci^{b,l}, S. Greco^a, F. Grespan^m, F.G. Lanzotti^{e,f,g}, D. Liuzzaⁿ, G. Maddaluno^a, P. Maccari^c, R. Marinari^c, F. Marino^{e,f}, D. Mascali^h, G.S. Mauro^h, D. Milanese^k, F. Mirizzi^f, A. Palmieri^m, A. Pepato^o, P. Petrolini^a, A. Pidotella^h, S. Piras^a, F. Pollastrone^{a,j}, C. Ponti^p, B. Raspante^a, G.L. Ravera^a, A. Rocchi^a, R. Romano^{a,b}, C. Salvia^g, G. Schettini^p, G. Spinella^p, G. Torrissi^h, A.A. Tuccillo^f, O. Tudisco^b, A. Turganbaevⁿ, L. Valletti^j, D. Van Eester^q, G. Vecchi^k, I. Venneri^d, F. Villone^{e,f}, H.S. Wu^r

^a ENEA, Nuclear Dept., Via Enrico Fermi 45, Frascati, 00044, (RM), Italy

^b DTT S.c. a r.l., Via Enrico Fermi 45, Frascati, 00044, (RM), Italy

^c ENEA, Nuclear Department, Località Brasimone, Camugnano, 40032, (BO), Italy

^d Eni Spa, EniProgetti, Località Facciolo, Triparni, 89900, (VV), Italy

^e University of Naples Federico II, DII, P.le Tecchio 80, Napoli, 80125, (NA), Italy

^f CREATE Consortium, Via Claudio 21, Napoli, 80125, (NA), Italy

^g University of Padua, Centro Ricerche Fusione, Corso Stati Uniti 4, Padova, 35127, (PD), Italy

^h INFN-LNS, Via S. Sofia 62, Catania, 95125, (CT), Italy

ⁱ Politecnico di Torino, Department of Applied Science and Technology, Corso Duca degli Abruzzi 24, Torino, 10129, (TO), Italy

^j University of Roma Tor Vergata, Department of Electronic Engineering, Via del Politecnico 1, Roma, 00133, (RM), Italy

^k Politecnico di Torino, Department of Electronics and Telecommunications, Corso Duca degli Abruzzi 24, Torino, 10129, (TO), Italy

^l CNR-ISTP, Via Roberto Cozzi 53, Milano, 20125, (MI), Italy

^m INFN-LNL, Viale dell'Università 2, Legnaro, 35020, (PD), Italy

ⁿ Università degli Studi del Sannio, Department of Engineering, Piazza Roma 28, Benevento, 82100, (BN), Italy

^o INFN, Sezione di Padova, Via Marzolo 8, Padova, 35131, (PD), Italy

^p Roma Tre University, Department of Industrial, Electronic, and Mechanical Engineering, Via Vito Volterra 62, Roma, 00146, (RM), Italy

^q ERM/KMS, Laboratory for Plasma Physics, Av. de la Renaissance 30, Brussels, 1000, Belgium

^r Politecnico di Torino, Department of Energy, Corso Duca degli Abruzzi 24, Torino, 10129, (TO), Italy

ARTICLE INFO

Keywords:

ICRH
DTT
Plasma heating

ABSTRACT

This paper describes the design and realisation status of the Ion Cyclotron Range of Frequency (ICRF) system of the Divertor Tokamak Test facility (DTT). DTT requires a large amount of additional heating partially provided by an ICRF system working in the frequency range from 60 to 90 MHz. The system will be modular, with each module aimed at coupling at least 3 MW for 50 s every hour to the DTT reference plasma as well as to contribute to wall cleaning tasks with lower power and higher duty cycle. Compared to existing and planned ICRF plants for tokamaks and stellarators, the radiofrequency system of DTT presents some peculiar features, mostly with reference to the technology of radiofrequency generators and to the mix of challenges the antenna design has to face like geometry decomposition, remote assembly and maintenance. The system design started some years ago and, in the last two years, 50+ collaborators contributed to make advances in its definition and development. Recently the ICRF system of DTT entered its realisation phase, with the issue of the first calls for tender, one of which for the procurement of two radiofrequency sources, while some aspects are still under design. This contribution gives a brief overview of the system architecture and focuses on the major advancements achieved in the latest years.

* Corresponding author at: ENEA, Nuclear Dept., Via Enrico Fermi 45, Frascati, 00044, (RM), Italy.
E-mail address: silvio.ceccuzzi@enea.it (S. Ceccuzzi).

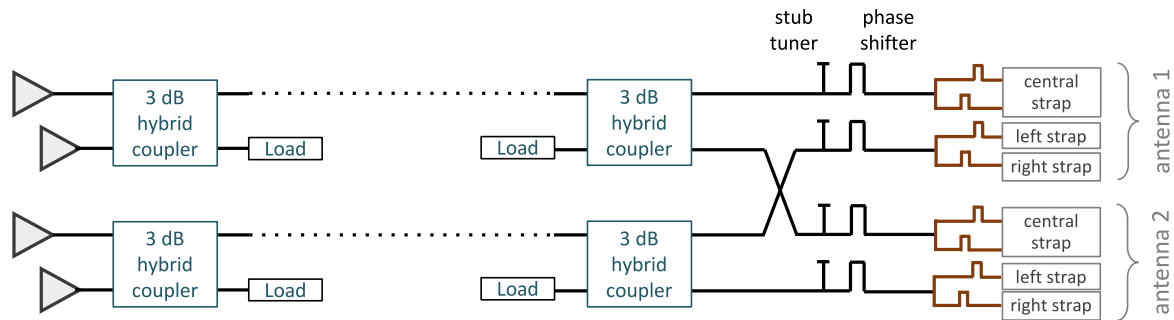

Fig. 1. Simplified circuit schematic of the ICRF system of DTT. Coaxial lines with characteristic impedance of 50 and 30 Ohm are respectively shown in black and orange colour.

1. Introduction

The Divertor Tokamak Test facility (DTT) is a tokamak under realisation in Italy whose main goals are to improve the experimental knowledge of heat exhaust in the operating conditions of a fusion reactor and to help choosing the best divertor solution for DEMO [1]. To this aim, DTT needs around 45 MW of auxiliary heating, that will be provided by electron cyclotron resonance heating, ion cyclotron range of frequencies (ICRF) and Neutral Beam Injection.

The ICRF heating of plasmas is widely used in several existing fusion machines based on magnetic confinement [2–4] and the deployment of new ICRF systems is planned in most reactor-relevant tokamaks [5–7]. The propagation of ICRF waves presents no density limit and, after understanding how to face issues such as coupling to ELMy plasmas and RF-induced sputtering [8], their heating effectiveness has been proven with H-mode plasmas in tokamaks with metallic walls.

The ICRF system of DTT is aimed at providing bulk ion heating and contributing to other tasks like wall cleaning and generation of fast particles. It will be composed of 1 (min) to 3 (max) modules, the final choice to be taken during the initial experimental phase of DTT. A preliminary definition of the ICRF module was presented in [9] and consisted of two diacode[®]-based transmitters, two, 4-feed, 2-strap antennas and an ELM-resilient matching scheme relying on external conjugate-T. Since then, this configuration has undergone major changes according to modifications in the DTT design, e.g., with reference to the available room in the ports, as well as to a more accurate cost assessment based on market surveys. In particular, grid tube technology was abandoned in favour of solid-state one, a 3-strap antenna concept was preferred, and 3 dB hybrid couplers were chosen in place of conjugate-T [10].

In the last two years, 50+ collaborators contributed to the design of the ICRF system of DTT, which entered its realisation phase. The recent progresses in its development are described in this paper.

2. System architecture

A simplified schematic circuit of the ICRF system of DTT is depicted in Fig. 1: transmitter outputs are combined in pairs and, after around 60 m, split by 3 dB hybrid couplers. Subsequently, the RF lines at the output of each 3 dB hybrid coupler are routed towards different antennas where, after an impedance transformer, feed equivalent straps. Each antenna has 4 feeds, so above-mentioned lines are split again by means of a T-junction and provided with other two phase shifters before being connected to antennas. Two feeds are for a central strap, which has an end-fed centre-grounded configuration, and the other two are for lateral straps, which feature a folded shape. Most route of RF lines rely on 9 3/16" rigid coaxial cables with characteristic impedance Z_0 of 50 Ohm, except close to antennas whose feeds use the 6 1/8" standard with Z_0 of 30 Ohm.

The operational frequency range is 60–90 MHz, allowing for on-axis minority heating of D(³He) and D(H) plasmas at the boundaries of the

interval. Each ICRF module is expected to couple 3 MW to the DTT reference plasma scenario for 50 s every hour and minimise derating in other magnetic configurations. During wall conditioning operations, a larger duty cycle of 1 h every two hours with a maximum coupled power of 200 kW was instead assumed [11].

3. Progress in system development

3.1. Transmitter

In the last decades, solid-state RF power amplifiers (SSPA) made outstanding advances, replacing grid tube technology even in high-power applications, like various accelerator fields [12], and attracting the attention of fusion community that started wondering whether semiconductor based RF amplifiers can fully replace tetrodes in ICRF generators or not [13]. This question was still open when DTT had to start the procurement of its first two ICRF transmitters, so a market survey was issued in 2022 to assess the existence of both interest and technical capacity among SSPA manufacturers to fulfil DTT needs. Suppliers' reply was very promising, accordingly DTT abandoned tetrode technology and opted for the procurement of fully solid-state transmitters.

They will be the first ones with such combination of output power, bandwidth and duty cycle. In detail, a maximum output power of 1.2 MW with a VSWR less than or equal to 1.5 is required in the bandwidth from 60 to 90 MHz for 50 s every hour. The transmitters can work with higher VSWR than 1.5 derating their output power and a fast shutoff is carried out if VSWR exceeds 3.0. Other operating modes, for example during wall conditioning or antenna conditioning, with lower power and higher duty cycle shall be also feasible. Details on their technical specifications can be found in [14].

The realisation of the first two transmitters was recently awarded. Each one will have more than 1500 LDMOS, with controlled drain voltage, and more than 300, hot-swappable, off-the-shelf power supplies. A broadband progressive combination of transistor outputs was preferred to a single-stage cavity combiner [15] that needs to be mechanically tuned to cover the specified frequency range. More precisely, a 5-stage combiner, whose detailed design is currently ongoing, will be used.

3.2. Transmission line and matching

Extensive circuit simulations have been carried out with Ansys[™] Electronic Desktop to check the performance of the reference RF circuit of Fig. 1 and to assess alternative designs. The antenna was modelled through its scattering matrix computed with TOPICA [16] for the DTT single-null scenario. Circuit simulations demonstrated that a stand-off voltage of 35 kV allows the reference circuit scheme to attain the target coupled power at all frequencies.

Several modifications to the reference design were studied, identifying an alternative feeding scheme for lateral straps, which is depicted in Fig. 2. This circuit provides flexibility in shaping the antenna spectrum

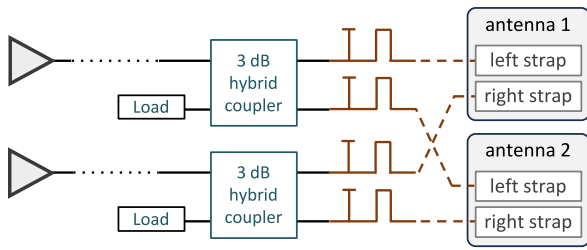

Fig. 2. Alternative feeding scheme of lateral straps. Colours and symbols are as in Fig. 1.

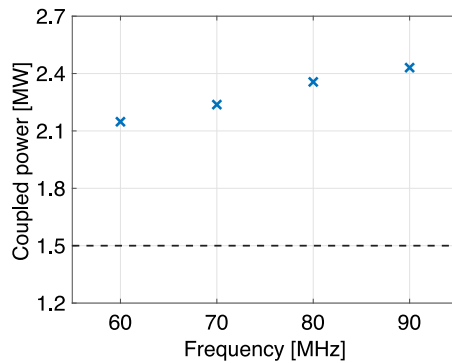

Fig. 3. Coupling performance, calculated with TOPICA for 0π phasing and equal coupled power between central and lateral straps.

and results in a lower forward power across stub tuners and trombones; nevertheless its use is under discussion because it is more expensive and ICRF current drive is not required in DTT.

In parallel with design activities, the procurement of RF components needed to test the combination of two transmitters under mismatching conditions has started. They include a broadband 3 dB hybrid coupler, an impedance transformer and a 2.5 MW dummy load. A testbed facility is required to test RF components, feedthroughs and antennas and it will be progressively deployed according to the planning of the tasks to be accomplished. The first testbed configuration, currently under procurement, will allow to perform the site acceptance test of the transmitters and to test 50 Ohm RF components.

3.3. Feedthrough and antenna

Several designs of feedthrough based on alumina ceramic were assessed, restricting the choice between conical shape and corrugated disk [17]. Further analyses [18] highlighted that the former design attains lower E-field value and is thus preferable. Preliminary thermo-mechanical analyses were also carried out showing that active cooling is unnecessary if feedthrough is outside cryostat and Ag- or Cu-coated [19].

As far as antenna design is concerned, several antenna concepts had been compared in terms of RF performance a few years ago in [10], using a flat approximation for their geometries, and a 3-strap antenna design had been identified as the most promising candidate. Since then, design activities focused on this choice with the aim to bring it to a higher level of maturity than a simplified, flat, conceptual RF model. In detail most efforts were put in drawing the curved shape of the antenna along toroidal and poloidal direction, designing its cooling circuit, defining procedure and steps to install the antenna in allocated ports, and selecting the materials of its subparts.

The poloidal antenna profile will match the single null DTT plasma on the top part and will detach from the plasma at the bottom to allow the antenna to be in the shadow of the first wall while retracted [20].

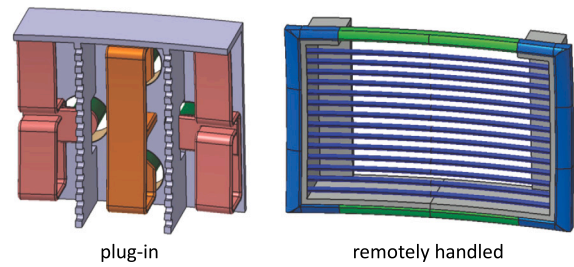

Fig. 4. Plug-in and remotely handled antenna parts.

Taking into account all geometrical constraints, the antenna design was optimised in terms of RF performance [21], reaching a coupling capability in single null scenario well above the target value of 1.5 MW. Its plot versus frequency has been computed with TOPICA, which was repeatedly validated against experimental data for this type of calculations [22]. The plot is shown in Fig. 3 and gives confidence about the achievement of acceptable performance also in different scenarios, which still have to be assessed. The optimisation also aimed at minimising RF electric fields parallel to the tokamak magnetic field [23], which, averaged 3 mm in front of a side limiter and normalised to a coupled power of 1.5 MW, are of the order of 1.5 kV/mm at 90 MHz.

According to computational fluid dynamics and thermo-mechanical analyses [24,25], an effective cooling circuit can be designed, providing antenna subparts with internal cooling channels, thus ruling out the need to introduce major geometrical modifications to the RF design to cope with high heat loads expected in DTT. The assembling through the remote handling system (RHS) is instead a major concern. The current design aims at separating the antenna into a plug-in and a remotely handled part [26]: as shown in Fig. 4, the former includes straps, septa and part of the box, while the latter consists in the remaining components like Faraday screen (FS) and limiters. The plug-in part will be installed by inserting it through the ICRF port; the remotely handled part will be installed by the RHS through a tailored gripper that is under design [27]. With a fully plug-in solution, coupling performance would be too low; on the other hand a fully remotely handled solution entails a heavy payload for the RHS and the need to develop troublesome RF contacts [28] to connect coaxial feeds.

The antenna is cantilevered and radially movable to adjust its radial position with respect to the plasma; electromagnetic simulations of its structure has just begun [29]. As far as materials are concerned, the reference choice still to be confirmed is to make additively manufactured straps of CuCrZr, FS bars of Molybdenum-Titanium-Zirconium (TZM), box of SS 316, and limiters of Tungsten.

4. Conclusions and next steps

The first two transmitters of the ICRF system of DTT are being procured. They will be fully solid-state amplifiers able to deliver an output power of 1.2 MW with VSWR of 1.5 for 50 s every hour over the frequency range from 60 to 90 MHz with no need of mechanical tuning, which is instead required in tetrode-based cavity amplifiers. Their broad-band feature will be achieved through a multi-stage combination of transistors, each one with an output power of around 1 kW.

In parallel, design activities are progressing at a fast pace, mostly focusing on the antenna and its feeding circuit. The former will be a 3-strap antenna concept, able to deliver more than 1.5 MW to the plasma in the DTT single-null scenario according to TOPICA simulations. Its geometry has been poloidally and toroidally bent, subject to integration constraints, to match as much as possible the plasma shape. Part of the antenna will be installed in (and disinstalled from) the tokamak through the remote-handling system and a preliminary design of both assembling procedure and antenna gripper have been carried out.

Advances have been done also with reference to the design of cooling circuit and the choice of antenna materials that will be mostly made of stainless steel, CuCrZr, TZM, and tungsten.

Next activities will focus on the antenna-RHS interface, electromagnetic simulations during disruptions and a more accurate prediction of heat loads on antenna limiters to help freezing material choice and manufacturing technologies.

CRedit authorship contribution statement

S. Ceccuzzi: Writing – review & editing, Writing – original draft, Visualization, Validation, Supervision, Software, Resources, Project administration, Methodology, Investigation, Funding acquisition, Formal analysis, Data curation, Conceptualization.

Declaration of competing interest

The authors declare that they have no known competing financial interests or personal relationships that could have appeared to influence the work reported in this paper.

Acknowledgements

This work has been partially carried out within the framework of the EUROfusion Consortium, funded by the European Union via the Euratom Research and Training Programme (Grant Agreement No. 101052200-EUROfusion). Views and opinions expressed are however those of the author(s) only and do not necessarily reflect those of the European Union or the European Commission.

Data availability

Data will be made available on request.

References

- [1] F. Romanelli, et al., Divertor tokamak test facility project: Status of design and implementation, *Nucl. Fusion* 64 (11) (2024) 112015, 29th IAEA Fusion Energy Conference (FEC 2023) Overview Papers.
- [2] V. Bobkov, et al., Making ICRF power compatible with a high-Z wall in ASDEX Upgrade, *Plasma Phys. Control. Fusion* 59 (1) (2017) 014022.
- [3] J.-M. Bernard, et al., Commissioning of the first WEST load-resilient long pulse ICRF launcher in the TITAN testbed and on WEST plasmas, *Fusion Eng. Des.* 146 (2019) 1778–1781, SI:SOFT-30.
- [4] J. Ongena, et al., Physics design, construction and commissioning of the ICRH system for the stellarator Wendelstein 7-X, *Fusion Eng. Des.* 192 (2023) 113627.
- [5] P. Lamalle, et al., Status of the ITER ion cyclotron heating and current drive system, in: *AIP Conference Proceedings*, Vol. 1689, (1) AIP Publishing, 2015.
- [6] Y. Lin, et al., Physics basis for the ICRF system of the SPARC tokamak, *J. Plasma Phys.* 86 (5) (2020) 865860506.
- [7] W. Zhang, et al., Conceptual design and optimization of an ITER-type ICRF antenna on CFETR, *Nucl. Fusion* 62 (7) (2022) 076045.
- [8] J.-M. Noterdaeme, Fifty years of progress in ICRF, from first experiments on the model C stellarator to the design of an ICRF system for DEMO, *AIP Conf. Proc.* 2254 (1) (2020) 020001.
- [9] S. Ceccuzzi, et al., Conceptual definition of an ICRF system for the Italian DTT, *Fusion Eng. Des.* 146 (2019) 361–364, SI:SOFT-30.
- [10] S. Ceccuzzi, et al., The ICRF antenna of DTT: Design status and perspectives, *AIP Conf. Proc.* 2984 (1) (2023) 030015.
- [11] G. Ravera, et al., Operational requirements of the ion cyclotron wall conditioning in DTT, *Fusion Eng. Des.* 191 (2023) 113754.
- [12] P. Marchand, Review and prospects of RF solid state power amplifiers for particle accelerators, in: *Particle Accelerator Conf. (IPAC2017)*, 2017, pp. 2537–2542.
- [13] H. Faugel, et al., The prospects of ICRF generators at ASDEX upgrade, *AIP Conf. Proc.* 2254 (1) (2020) 070006.
- [14] C. Salvia, et al., Design Specifications for the Ion Cyclotron Heating Amplifier System in the Divertor Tokamak Test Facility, *this conference* P3-88.
- [15] D. Regidor, et al., IFMIF-DONES RF system, *Fusion Eng. Des.* 167 (2021) 112322.
- [16] V. Lancellotti, et al., TOPICA: an accurate and efficient numerical tool for analysis and design of ICRF antennas, *Nucl. Fusion* 46 (7) (2006) S476–S499.
- [17] F. Mirizzi, et al., Comparative analysis of vacuum feedthroughs for the DTT ICRH system, *IEEE Trans. Plasma Sci.* (2024).
- [18] S. Greco, et al., RF Modeling and Design of Feedthroughs for the ICH System of DTT, *this conference* P3-6.
- [19] L. Valletti, et al., Multiphysics analysis of high-power vacuum feedthrough for DTT ICRH system, in: *2023 Photonics & Electromagnetics Research Symposium (PIERS)*, 2023, pp. 543–551.
- [20] G. Camera, et al., Preliminary conceptual design of the ICRH antenna for DTT: A systems engineering approach, *IEEE Trans. Plasma Sci.* (2024).
- [21] F. Mirizzi, et al., Progress in the design of the ICRF launcher for DTT, *this conference* P3-22.
- [22] F. Durodié, et al., Latest achievements of the JET ICRF systems in view of ITER, in: *Proceedings of the 23rd IAEA Fusion Energy Conference*, International Atomic Energy Agency, 2010.
- [23] V. Bobkov, et al., Impact of ICRF on the scrape-off layer and on plasma wall interactions: From present experiments to fusion reactor, *Nucl. Mater. Energy* 18 (2019) 131–140.
- [24] R. Marinari, et al., Thermal hydraulic and mechanical assessment of the DTT ICRH antenna, in: *20th Int. Topical Meeting on Nuclear Reactor Thermal Hydraulics (NURETH-20)*, American Nuclear Society, 2023, pp. 4602–4615.
- [25] R. Marinari, et al., Analyses and design of the cooling system for the DTT ICRH antenna, *this conference* P3-32.
- [26] G. Camera, et al., Conceptual selection of the RH strategy for the DTT ICH antenna, *this conference* P2-34.
- [27] F. Marino, et al., Requirements Engineering and Conceptual Design of RH Gripper for DTT ICH Antenna, *this conference* P2-40.
- [28] J. Hillairet, et al., Radiofrequency and mechanical tests of silver coated CuCrZr contacts for the ITER ion cyclotron antenna, *Fusion Eng. Des.* 129 (2018) 29–39.
- [29] G. Camera, et al., Preliminary electromechanical analysis of the DTT ICRH antenna current straps, *this conference* P3-38.