

Experimental investigation of a novel modular multi-purpose floating structure concept

Original

Experimental investigation of a novel modular multi-purpose floating structure concept / Giorcelli, F.; Niosi, F.; Glorioso, M.; Paduano, B.; Sirigu, S. A.. - ELETTRONICO. - (2024), pp. 807-814. (6th International Conference on Renewable Energies Offshore, RENEW 2024 Lisbon (POR) 19-21 November 2024) [10.1201/9781003558859-88].

Availability:

This version is available at: 11583/2995190 since: 2026-02-18T09:46:17Z

Publisher:

CRC Press/Balkema

Published

DOI:10.1201/9781003558859-88

Terms of use:

This article is made available under terms and conditions as specified in the corresponding bibliographic description in the repository

Publisher copyright

Taylor and Francis postprint/Author's Accepted Manuscript con licenza CC by-nc-nd

This is an Accepted Manuscript version of the following article: Experimental investigation of a novel modular multi-purpose floating structure concept / Giorcelli, F.; Niosi, F.; Glorioso, M.; Paduano, B.; Sirigu, S. A.. - ELETTRONICO. - (2024), pp. 807-814. (6th International Conference on Renewable Energies Offshore, RENEW 2024 Lisbon (POR) 19-21 November 2024) [10.1201/9781003558859-88].. It is

(Article begins on next page)

Experimental investigation of a novel modular multi-purpose floating structure concept

F. Giorcelli, F. Niosi, M. Glorioso, B. Paduano & S.A. Sirigu

Marine Offshore Renewable Energy Lab, Department of Mechanical and Aerospace Engineering, Politecnico di Torino, Torino, Italy

ABSTRACT: Modular multi-purpose floating structures (MMFS) provide a possible solution to the growing need for space resulting not only from the rapidly growing global population but also from the emerging blue economy and specifically offshore renewables sector. The desired space is generated in a more sustainable way than traditional land reclamation methods, by interconnecting together modular floating platforms, making this technology adaptable and suited to a broad range of possible offshore activities. This study experimentally investigates the hydrodynamic response of a novel concept of modular multi-purpose floating structure, composed by floating modules connected with semi-rigid connectors and moored at the seabed using a taut mooring system solution. The 1:50 model consists of three hexagonal floating platforms, linked together by a semi-rigid connector system that emulate the mechanical behaviour of the full-scale system. The model has been tested under representative sea state conditions at the wave basin of the Laboratory of Hydraulic Engineering (LIDR) of Università degli Studi di Bologna. This paper describes the experimental setup and preliminary results of the dynamic behaviour of the MMFS system, with particular focus on platforms kinematics, mooring and connectors loads.

1 INTRODUCTION

Nowadays, large floating platforms are attracting more and more interest as they can potentially be adopted for various applications of the growing blue economy activities. For example, these systems can be used to support the emerging floating renewables industry as a logistics support base, for O&M operations and the installation of offshore plants. Further applications may include support for aquaculture, seaweed farming and vertical farming activities for countries suffering from land shortages; or the creation of floating port terminals to solve the problem of shipping congestion (Lamas-Pardo et al. 2015).

The strong urban pressure on coastal communities and the problem of land shortage are placing great emphasis on floating solutions as a sustainable alternative to current land reclamation practices based on the dredging technique (Wang et al. 2006). This technique consists of filling water areas with inert material and building protective walls with devastating impacts on local environmental balances (Nightingale 2001). Another promising and environmentally less impactful approach is the adoption of very large floating structures (VLFS) to create new land on water (Wang et al. 2006). These structures are composed of floating modules, which can be rigidly intercon-

nected or linked through semi-rigid connections, and anchored to the seabed by means of a mooring system. The main factors that have hindered the development of VLFS are the high costs and technological development limitations, primarily attributed to the high loads and corrosive marine environment (Wang and Tay 2011). In order to decrease the loads acting on the floating structures and reduce production costs, various solutions of modular platforms have been proposed in the literature, along with various proposals for connection systems aimed at mitigating the loads caused by the hydroelastic response of the system (Andrianov 2005). Despite the strong interest in this technological solution, there are still significant knowledge gaps for its development. In literature, studies regarding the numerical models of moored VLFS (Bispo et al. 2023, Bispo et al. 2022) and their analysis are proposed but experimental campaigns are necessary to validate the proposed concepts. Experimental tests on these structures have indeed highlighted that challenges related to the hydroelastic response of VLFS remain to be addressed (Waals et al. 2018), as well as the high loads on the connection and mooring system due to wave action, and issues concerning comfort and safety during extreme events (Wu et al. 2023).

Within this context, this paper aims to describe a

novel modular multi-purpose floating structure concept and the preliminary experimental results conducted on a scaled prototype.

The concept is based on interconnected floating modules linked together via a semi-rigid connection system and anchored to the seabed using a taut mooring system composed of pre-tensioned synthetic material lines, such as nylon. The taut elastic mooring system provides better station keeping characteristics than catenaries and, in addition, the absence of chains on the seabed reduces the impact of mooring on the marine ecosystem. A semi-rigid connection constitutes an optimal balance between connection stiffness and relative motion between platforms, and the optimal value of stiffness has been investigated in previous work (Sirigu et al. 2023). The main objective of this paper is to describe the experimental setup of tests conducted on a representative layout of the new concept of modular floating structure, whose characteristics have been previously analysed through numerical models. Thus, preliminary results of these experimental tests are presented with main focus on the dynamic behaviour of the system and loads acting on mooring and connections.

2 EXPERIMENTAL SETUP

In this section, the description of the experimental campaign setup is provided and discussed.

2.1 Model description

This subsection provides a brief description of the scaled model of the novel MMFS concept, with details regarding the hexagonal floating modules, the semi-rigid connection system, and the taut mooring system. The model scale is 1:50 and the Froude's law is used to size the system parameters. The hexagonal floating platform is shown in Figure 1. As sketched in Figure 2 the tested concept consists of three hexagonal floating platforms connected via semi-rigid connectors and four taut mooring lines, equipped with sensors and designed to replicate the mechanical characteristics of the full-scale system. The design parameters of the model are given in Table 1. The connection system has been specially designed for the experimental tests to ensure the bending (pitch), shear (heave) and tensile (surge) stiffness properties of the full-scale connector and to enable the installation of sensors for force measurement. The connection system is depicted in Figure 3 where the five links, consisting of pistons inside which are the elastic components, are highlighted. During the campaign, two different elastic elements have been tested, mechanical springs and rubber. Details of the connection system are shown in Figure 4, highlighting the spring element inside the piston and the load cell mounted in the link to measure the forces involved. Regard-

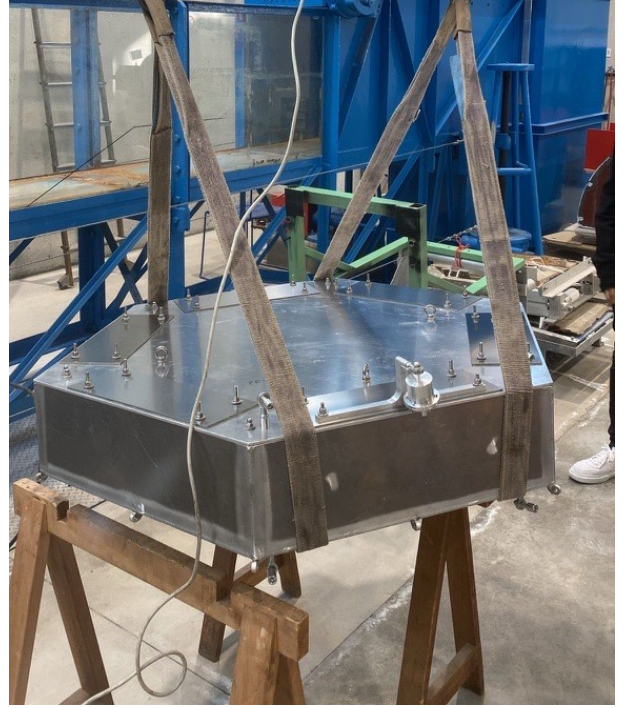

Figure 1: 1:50 hexagonal floating platform model.

Table 1: Scaled model parameters using Froude's law.

Parameter	Unit	1:50 model
floaters diameter	(m)	1.08
floaters height	(m)	0.18
floaters edge length	(m)	0.54
draft	(m)	0.12
three platform system length	(m)	2.92
CoG distance from the deck	(m)	0.04
distance between platforms	(m)	0.06
floaters pitch inertia	(kgm ²)	8.26
floaters roll inertia	(kgm ²)	8.26
floaters yaw inertia	(kgm ²)	13.34
floaters mass	(kg)	93.20
mooring line length	(m)	1.09
mooring line spring stiffness	(N/m)	130
connection spring stiffness	(N/m)	88500

ing the station-keeping system, two different mooring line layouts have been tested. Two configurations were tested. The first configuration consists of a linear extension spring and a high stiff polyester rope. This configuration aims to validate the numerical models used for design. The second mooring configuration implements, on the other hand, a mooring line made entirely of nylon, in order to investigate the behaviour of this highly nonlinear material and used to realise the mooring of the full-scale system.

2.2 Wave tank and data acquisition system

The experimental tests have been performed in the the wave basin of the Laboratory of Hydraulic Engineering (LIDR) of Università degli Studi di Bologna. Figure 5 illustrates a sketch of the experimental setup and wave basin, whose dimensions are 12.00 m x 8.00 m x

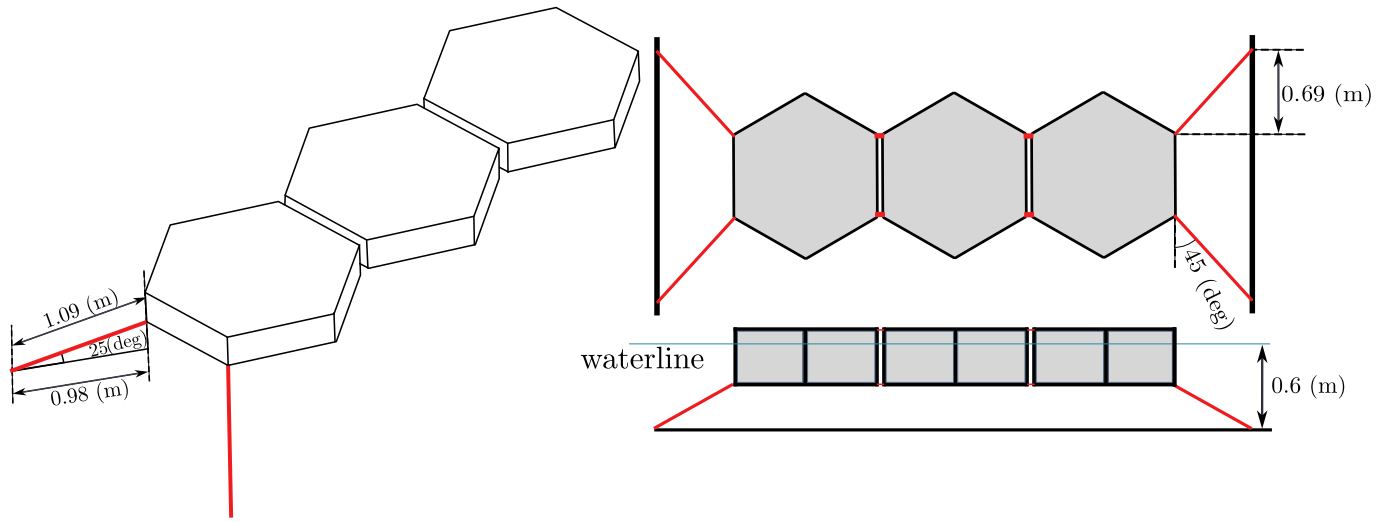

Figure 2: 1:50 tested model layout of the MMFS system.

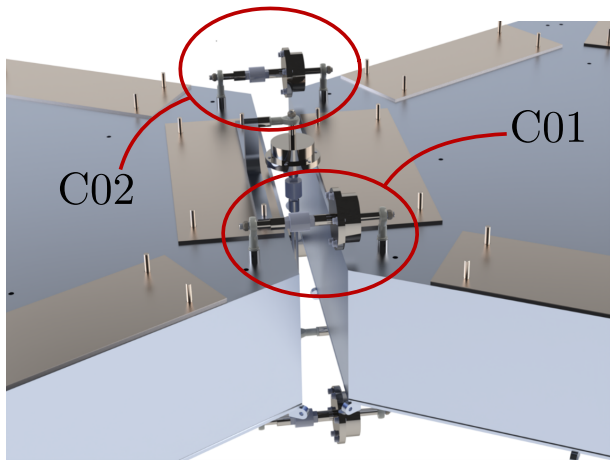

Figure 3: Platform 01 and 02 CAD render of the connection system. The same connections configuration is used for the second and third floater connection.

0.60 m in length, width, and water depth, respectively. 12 wave gauges (WG01 to WG12), able to measure the wave elevation η , have been installed. The probes position in the experimental layout are described in Figure 5, where the wave gauges removed during the course of the tests are reported in shaded colors. The experimental setup is also equipped with an optical motion tracking system (Qualisys system) for the acquisition of the motion of the three floaters. The model is provided with onboard sensors in order to measure the connectors and mooring loads. The acronym list of the experimental layout elements is given in Table 2. The experimental data acquisition system is organized into three main interconnected subsystems: the C-RIO9042 (National Instruments) module for the data acquisition of mooring lines and connectors load cells, the motion capture camera system which comprises four cameras and the wave tank acquisition system responsible for the wave elevation measurement by means of the wave gauges. A trigger signal is used to synchronise the three measurement subsystems. The acquisition system layout is described in Figure 6.

2.3 Test matrix

This study aims to investigate the hydrodynamic response of the proposed novel concept of MMFS under various representative sea state conditions. The representative regular and irregular sea states tested during the experimental campaign are given in Table 4. Moreover, several system layouts have been investigated: three platforms with linear spring mooring line and connection (LAY1) nylon mooring line and linear spring connection (LAY2) nylon mooring line and rubber connection (LAY3) linear spring mooring and rubber connection (LAY4), and single floater system with spring mooring line (resumed in Table 3). Figure 8 shows a picture of the model during an experimental test.

Table 2: Acronyms used to describe the experimental setup.

Acronym	Meaning
ML01	Mooring Line 01 + Load Cell
ML02	Mooring Line 02 + Load Cell
ML03	Mooring Line 03 + Load Cell
ML04	Mooring Line 04 + Load Cell
C01	Connection 01 + Load Cell
C02	Connection 02 + Load Cell
C03	Connection 03 + Load Cell
C04	Connection 04 + Load Cell
WG01	Wave Gauge 01
WG02	Wave Gauge 02
WG03	Wave Gauge 03
WG06	Wave Gauge 06
WG07	Wave Gauge 07
WG10	Wave Gauge 10
WG11	Wave Gauge 11
WG12	Wave Gauge 12
P01	Platform 01
P02	Platform 02
P03	Platform 03

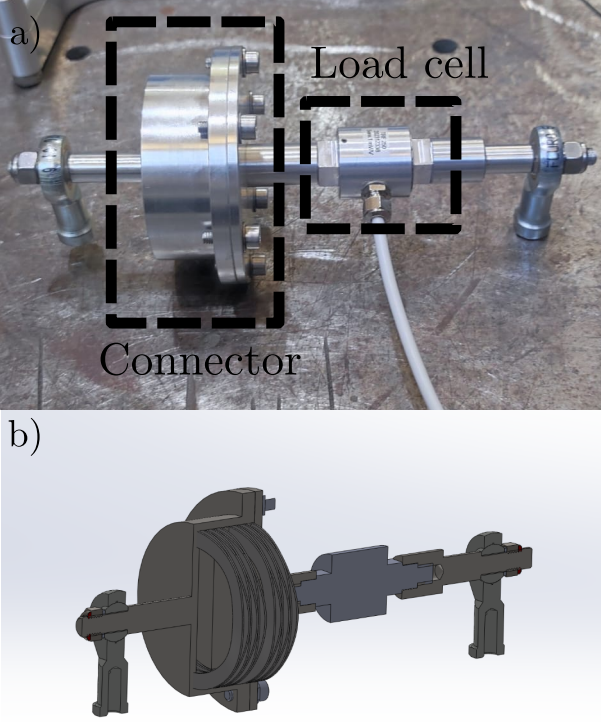

Figure 4: In a) the mechanical connector link with the relative load cell and in b) its cross-section with the piston and the spring as elastic component.

Table 3: Tested MMFS configurations.

Layout	Mooring	Connection
LAY1	spring	spring
LAY2	nylon	spring
LAY3	nylon	rubber
LAY4	spring	rubber
LAY5	spring	-

3 PRELIMINARY RESULTS

Within this section, the preliminary results obtained concerning the MMFS system motion and loads acting on both mooring lines and connections are assessed for the spring connection with mooring line configuration (LAY1). In the context of the present work, the measured data are synchronised using the trigger signal discussed above and post-processed in MATLAB environment.

3.1 Time domain analysis

The MMFS under analysis is designed to be able to maintain adequate stability and comfort, which have to be suitable for both possible industrial and residential uses. Therefore, in addition to the dynamic response of the system to the stress occurring in the various operating conditions tested, it is worth examining the outcomes pertaining to the temporal histories of the main systems motion. The kinematic vector \vec{x} is

Table 4: Irregular and regular sea states conditions tested.

Name	T_p (s)	H_s (mm)
IRR1	0.71	20
IRR2	0.85	22
IRR3	0.99	31
IRR4	1.13	40
IRR5	0.71	26
IRR6	0.85	37
IRR7	0.99	51
IRR8	1.13	67
Name	T (s)	H (mm)
REG1	0.71	16
REG2	0.92	26
REG3	1.13	40
REG4	0.71	26
REG5	0.92	44
REG6	1.13	67

defined as

$$\vec{x} = \begin{bmatrix} x_{1,n} \\ x_{2,n} \\ x_{3,n} \\ x_{4,n} \\ x_{5,n} \\ x_{6,n} \end{bmatrix} = \begin{bmatrix} surge \\ sway \\ heave \\ roll \\ pitch \\ yaw \end{bmatrix}, \quad (1)$$

where n identifies the n^{th} -floater of the configuration under analysis. In Figure 9 the evolution in time concerning the analysed configuration (LAY1) is plotted for the Degrees of Freedom (DoFs) of major interest in this study, *i.e.* x_1 , x_3 , and x_5 . The results regard the IRR8 sea state have been chosen because this wave condition can be considered as a representative high-stress sea state for the system, almost comparable with an extreme operative situation. Moreover, in Figure 10 the time history is reported also for the loads acting on connections elements and mooring lines. The data collected during the experiments show a proper coupled evolution in time domain for various sets of load cells with respect to their positioning in the wave tank layout. Focusing on the connections, the bow pair of load cells (C01 and C02) measure a higher forces than the two systems connecting mid-ship and stern floaters (C03 and C04), as expected. Furthermore, the magnitude of the measured data lies below adequate values both for a structural and comfort purposes perspective, *i.e.* no mooring line approaches slack condition (in which the line tension would collapse to 0 N) and each maintains appropriate load values to ensure and adequate station keeping. Therefore, the obtained outcomes describe acceptable performances. The outcomes for the other sea states and configurations are not reported here, they turn out to be consistent and similar to those investigated in this study.

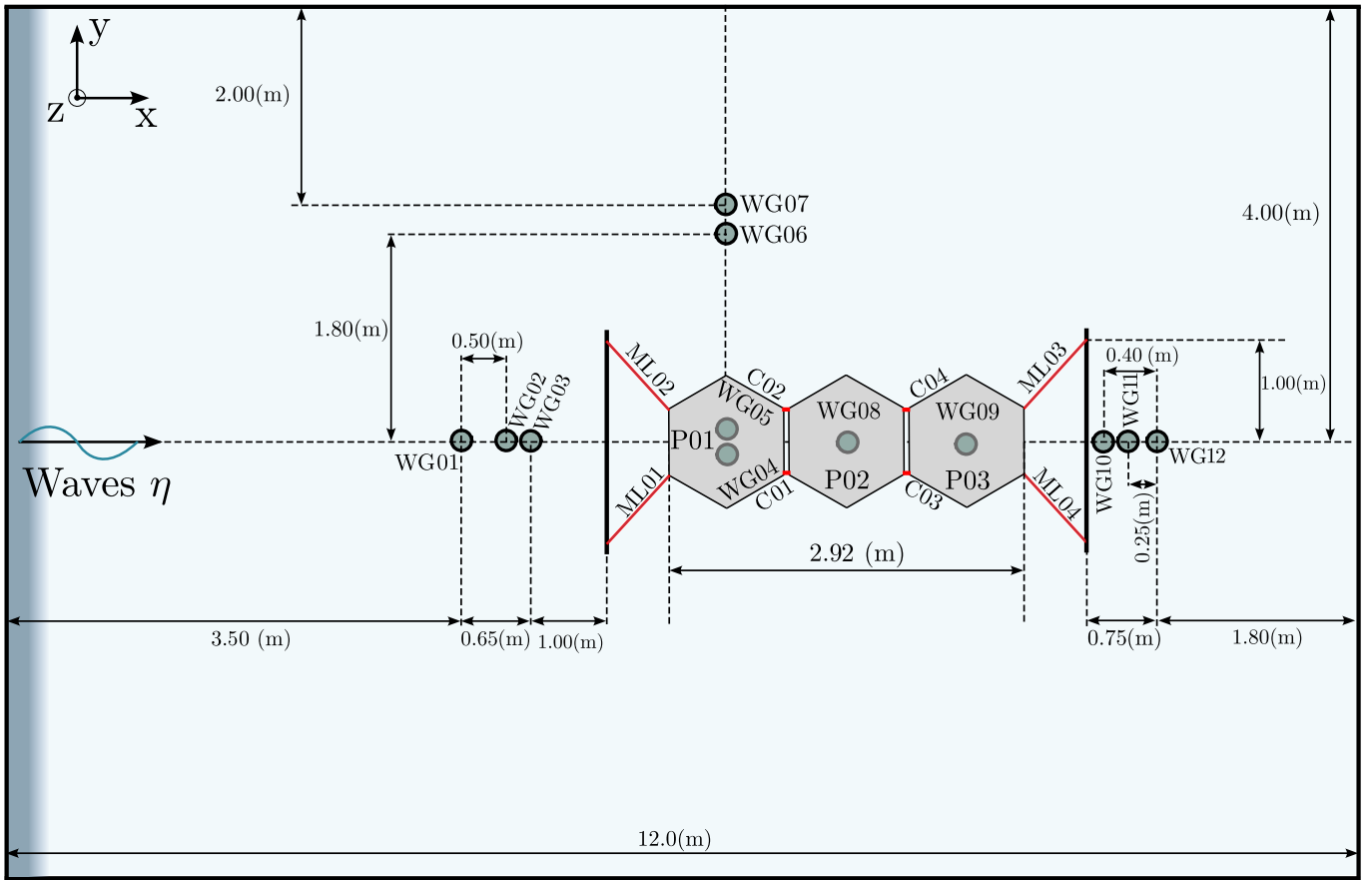

Figure 5: Wave basin experimental setup.

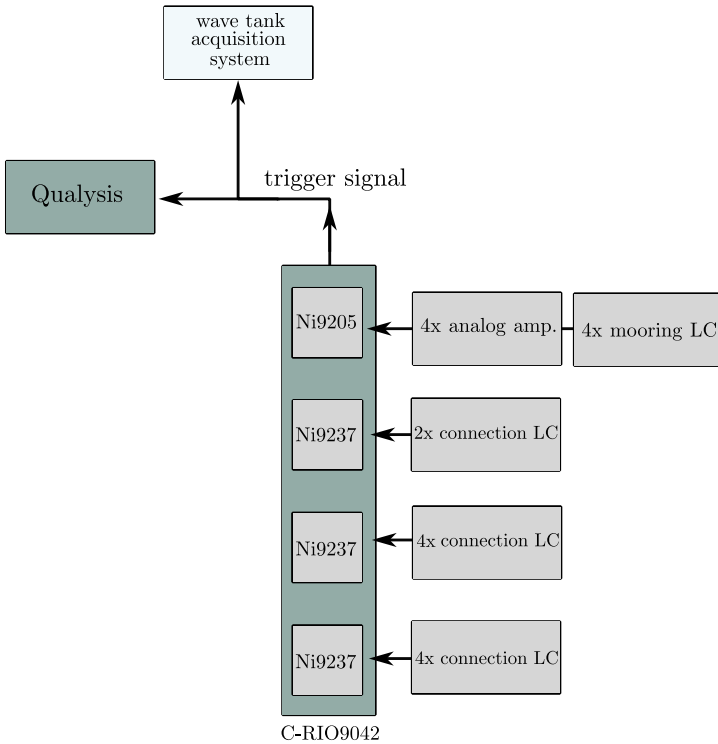

Figure 6: Experimental data acquisition system setup, with the three subsystem used for the measurement: Qualysis for the motion capture, C-RIO9042 for the mooring lines and connectors loads, and the wave tank acquisition system for the wave elevation.

3.2 Frequency domain analysis

Within this subsection, the same configuration LAY1 and sea state IRR8 of the previous section has been investigated. The dynamic behaviour of the MMFS

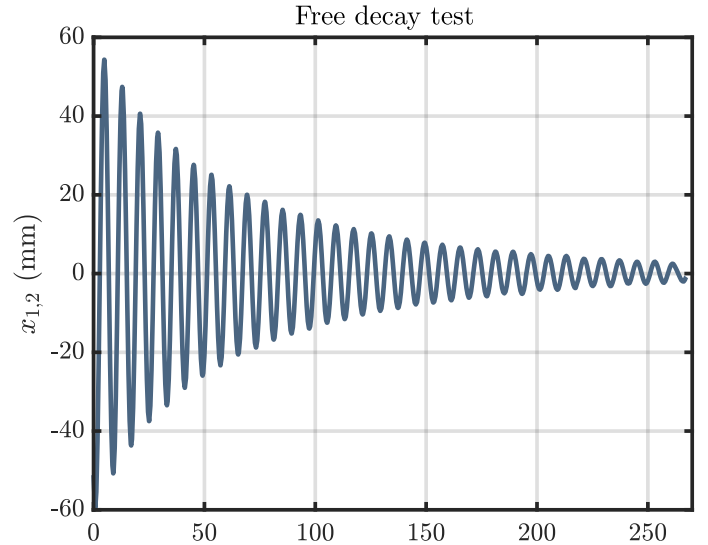

Figure 7: Free decay test for the surge DoF of the mid-ship platform.

is analysed in the frequency domain by means of the Fourier transform (\mathcal{F}) of the measured displacements of the system. By observing the Fourier transform of the surge motion amplitude for the mid-ship platform in Figure 11, it is possible to divide the frequency response in two main regions: a low-frequency response range, governed by mooring system resonance, and higher-frequency response range governed by wave frequency response. The data show a significant motion amplitude in the low-frequency region which, according to literature (Faltinsen 1993), is mainly generated by the system resonance (f_{res} in Figure 11)



Figure 8: The MMFS tested system during an operative sea state experiment at the LIDR facility.

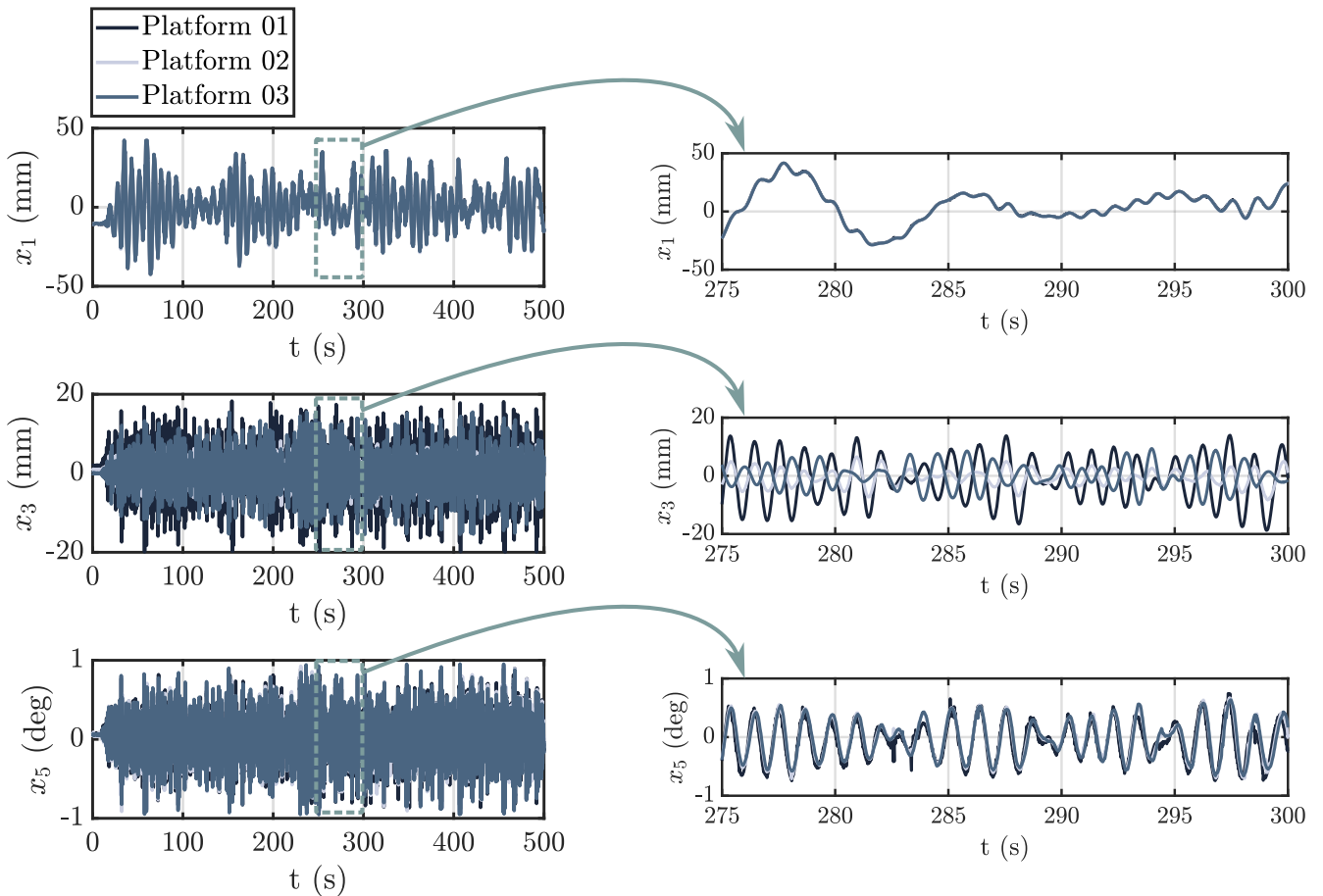

Figure 9: LAY1 time histories for the surge, heave and pitch motions for each platform under IRR8 sea state operative scenario. In the figure a zoom on a shorter time (from 275 s to 300 s) of each subplot is reported in order to highlight the trend of the outcomes. The difference in the surge motion of the three platforms is very small, hence the three lines are overlapped.

which is highly affected by the stiffness properties of the mooring lines. In Figure 7, the free decay test performed in order to evaluate the resonance frequency of the investigated system for the surge DoF is reported. The experiment data are processed via logarithmic decrement technique, which returns a f_{res} equal to 0.12 Hz. Moreover, it is worth to highlight that the range of frequencies of the sea state weakly excites the MMFS (*i.e.* the magnitude of the surge frequency response is low). Therefore, the sea state energy content is localised in a frequencies range far enough from the mooring resonance region. It is

possible to conclude that the model is properly designed, since the mooring resonance period is far from the characteristic periods of operative sea waves that would cause strong displacement in the system, resulting in increased loads and safety issues on board.

4 CONCLUSIONS & FUTURE WORK

Modular multi-purpose floating structures offer a sustainable solution to the increasing demand for space driven by both the expanding global population and

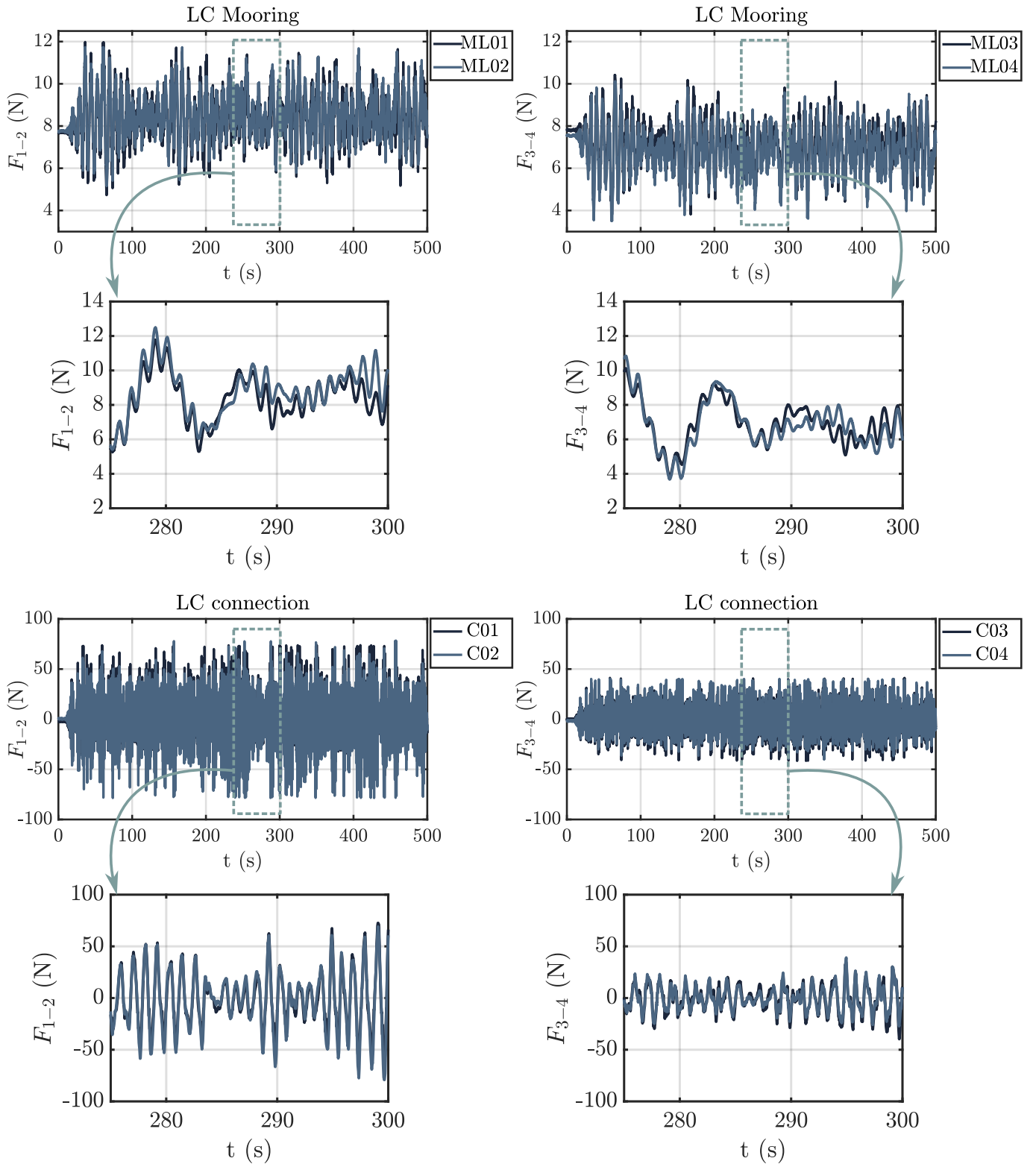

Figure 10: Time histories of loads acting on both stern (C01, C02, ML01 and ML02) and bow (C03, C04, ML03 and ML04) connectors and mooring lines for the LAY1-IRR8 sea state operative scenario. In the figure a zoom on a shorter time (from 275 s to 300 s) of each subplot is reported in order to highlight the coupled trend of the outcomes.

the rise of the blue economy sector. This study delves into the experimental investigation of a 1:50 scale model of a novel concept of MMFS, which consists in hexagonal modular floating platforms linked via semi-rigid connectors and anchored to the seabed using a taut mooring system configuration. Experimental tests are conducted under various sea state conditions which are representative of full-scale operative conditions. The tests investigate various system configurations correspondent, with a particular focus

on various implementation elements of mooring lines and connections. The preliminary results of configuration LAY1, which considers connectors and moorings realised with linear elastic springs, are presented in this study. The collected data show a proper hydrodynamic response in terms of both wave to motion and wave to loads (acting on mooring lines and connectors elements) under the tested operative waves conditions. The taut mooring system shows a satisfactory behaviour under a representative extreme condi-

tion (IRR8) and no mooring line reach the slack condition. It is highlighted that the resonance period of the mooring system is far from the characteristic periods of operational and extreme waves, emphasising the proper design of the mooring system to reduce system motions and loads, for increased safety and comfort. In conclusion, throughout the various exper-

ACKNOWLEDGEMENTS & FUNDING

The authors express their gratitude for the funds received from the Ministry of University and Research and PNRR's PhD scholarship program defined in DM-352/2022 in collaboration with Eni S.p.A. This publication is part of the PNRR-NGEU project.

REFERENCES

- Andrianov, A. (2005). Hydroelastic analysis of very large floating structures.
- Bispo, I., P. Amouzadrad, S. Mohapatra, & C. G. Soares (2023). Motion analysis of a floating horizontal set of interconnected plates based on computer vision target tracking technique. In *Advances in the Analysis and Design of Marine Structures*, pp. 153–159. CRC Press.
- Bispo, I., S. Mohapatra, & C. G. Soares (2022). Numerical analysis of a moored very large floating structure composed by a set of hinged plates. *Ocean Engineering* 253, 110785.
- Faltinsen, O. (1993). *Sea loads on ships and offshore structures*, Volume 1. Cambridge university press.
- Lamas-Pardo, M., G. Iglesias, & L. Carral (2015). A review of very large floating structures (vlfs) for coastal and offshore uses. *Ocean Engineering* 109, 677–690.
- Nightingale, Barbara; Simenstad, C. (2001). Dredging activities : marine issues. Technical report, University of Washington.
- Sirigu, S. A., V. Boccanfuso, & F. Carapellese (Tokyo, Japan, 28-29 August 2023). Multi-body analysis of modular floating islands: optimisation of connector stiffness. *Proc. of the Third World Conference on Floating Solutions (WCFS2023)*.
- Waals, O. J., T. H. J. Bunnik, & W. J. Otto (2018). Model tests and numerical analysis for a floating mega island. *Volume 1: Offshore Technology*, V001T01A016.
- Wang, C. & Z. Tay (2011). Very large floating structures: Applications, research and development. *Procedia Engineering* 14, 62–72. The Proceedings of the Twelfth East Asia-Pacific Conference on Structural Engineering and Construction.
- Wang, C. M., E. Watanabe, & T. Utsunomiya (2006, 4). *Very large floating structures*. CRC Press.
- Wu, L., H. Jiang, X. Ji, X. Ju, Z. Xiang, & M. Gu (2023). Hydrodynamic constraint loads estimation on connectors of column-pontoon type very large floating structure (cp-vlfs) under wave stimulation. *Frontiers in Marine Science* 10.

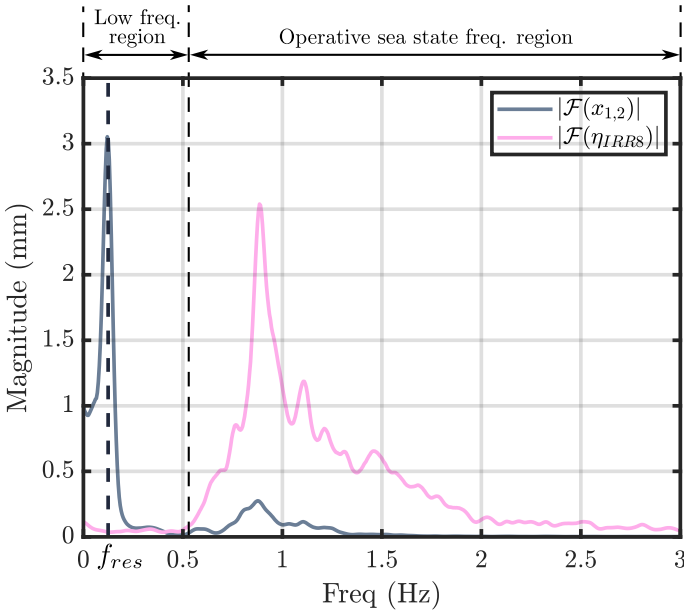

Figure 11: MMFS layout (LAY1) surge DoF in the frequency domain for the mid-ship floater. The grey line describes the mid-ship platform's surge frequency response absolute value ($|\mathcal{F}(x_{1,2})|$) under the irregular sea state condition (IRR8), the pink line is used to represent the wave elevation input ($|\mathcal{F}(\eta_{IRR8})|$), and the dashed line is correspondent to the mid-ship resonance frequency ($f_{res} = 0.12$ Hz).

iments, the novel MMFS demonstrates its capability to guarantee a proper stability for each tested configuration and under each operative condition, suitable for both residential and industrial purposes. The proposed model experimental investigation limitations regard the use of a linear spring mooring line instead of an accurate representation of the nonlinear behaviour of moorings. To counterbalance this deficiency, a full nylon mooring line configuration is tested in order to adequately represent classic nonlinear phenomena (e.g. dynamic stiffness hysteresis) of synthetic mooring systems. Moreover, an equivalent linear simplification of the connectors is used in the present experimental investigation, which also allows the roll motion between platforms. Then, Froude's scaling law involves accuracy limitation on drag and viscous phenomena representation. At last, only the MMFS response to mono-directional waves is investigated, neglecting the real-world multi-directional ones. Further studies will involve the calibration and validation of the numerical models and the investigation of the system's behaviour for other configurations and waves not addressed in this preliminary work.