

Digital twins for conservation - Digital twin strategy

Original

Digital twins for conservation - Digital twin strategy / Patrucco, G., Perri, S., Sammartano, G., Spano', A. - In: The Halls of Turin Exhibition Center by Pier Luigi Nervi: a multi-disciplinary approach for diagnosis and preservationELETTRONICO. - Los Angeles : Getty foundation, 2023. - pp. 452-475

Availability:

This version is available at: 11583/2993745 since: 2024-10-29T13:55:08Z

Publisher:

Getty foundation

Published

DOI:

Terms of use:

This article is made available under terms and conditions as specified in the corresponding bibliographic description in the repository

Publisher copyright

(Article begins on next page)



Politecnico
di Torino

Turin Exhibition Center

A MULTI-DISCIPLINARY APPROACH
FOR DIAGNOSIS AND PRESERVATION

CONSERVATION PLAN



**Politecnico
di Torino**

The Halls of Turin Exhibition Center by Pier Luigi Nervi: a multi-disciplinary approach for diagnosis and preservation

Turin, 2022

Published with support from Getty through its Keeping It Modern initiative

List of the authors:

Rosario Ceravolo (Project Lead)

Paolo Faccio (Project Vice-Lead)

Cristiana Chiorino, Erica Lenticchia, Antonia Spanò, Francesco Tondolo (Team Leads)

Donato Abruzzese, Greta Bruschi, Irene Matteini, Gaetano Miraglia, Giulia Sammartano (Task Leads)

Martina Bellemo, Amedeo Manuello Bertetto, Alberto Carollo, Sonia Cattazzo, Stefania Coccimiglio, Marco Crivellaro, Francesco Dall'Armi, Antonio Di Sanzo, Agnese Farnè, Rossana Gabrielli, Daniela Gastaldi, Paolo Guarino, Carlo Marocchini, Andrea Micheletti, Francesca Pasqual, Giacomo Patrucco, Stefano Perri, Antonino Quattrone, Francesco Rizzi, Elvira Smiriglia, Gerardo Sorrentino, Virginia Sparascio, Alessandro Tiero, Srey Mom Vuth.

The present Conservation Plan was developed within the framework of a memorandum of understanding between Politecnico di Torino - Department of Structural, Geotechnical and Building Engineering, the Municipality of Turin, and SCR Piedmont contracting authority.

Editorial Assistant: Francesca Pasqual

Graphic Design: Ermes Multimedia digital design

Cover images by Fabio Oggero



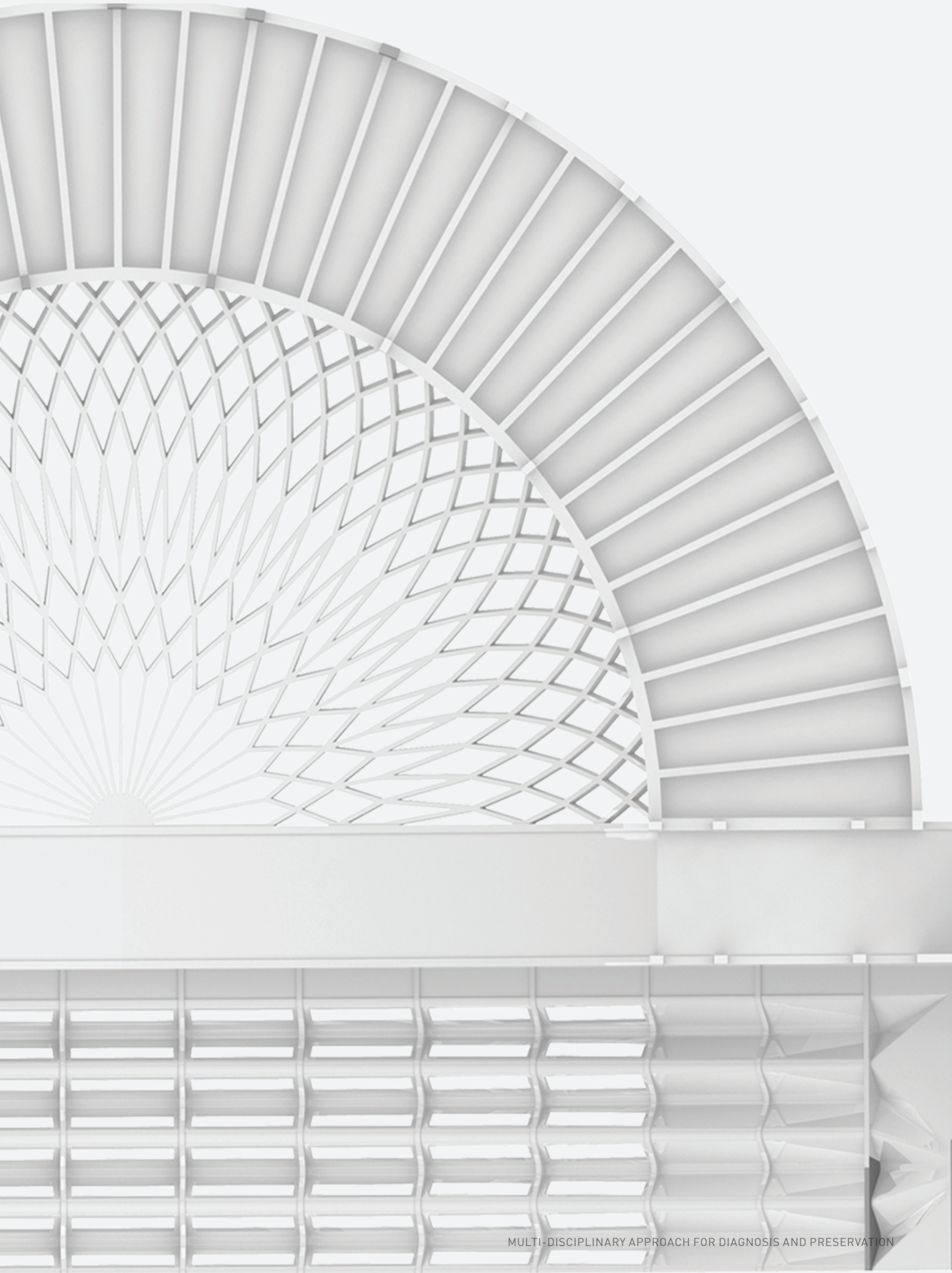



**Politecnico
di Torino**



**PN
LN**
PROJECT

Department of Structural, Geotechnical and Building Engineering (DISEG), Politecnico di Torino

Founded in 1860 as an experimental institution of the Royal School of Application, DISEG counted leading scientists like A. Castigliano, C. Guidi, V. Volterra, G. Colonnetti, G. Albenga, P. Cicala, G. Oberti, F. Levi. DISEG currently has about 70 professors and research staff and relies on several thematic laboratories, including an official governmental lab for testing on materials and structures (MASTRLAB) and a Disaster Planning LABORatory (DIPLAB). Since the 1990s the Earthquake Engineering & Dynamics (EED) thematic lab operates in structural health monitoring and seismic reliability assessment, with emphasis on cultural heritage.

In 2014, the City of Turin and the Politecnico of Turin signed a Memorandum of Understanding for the recovery and re-functionalization of the two halls of Torino Esposizioni.

Headed by Marco, one of the grandchildren of Pier Luigi Nervi, the Foundation has been engaged in coordinating the scientific research and financial support that allowed the birth and development of the **international traveling exhibition "Pier Luigi Nervi Architecture as Challenge"**. In addition to this exhibition, which has been enriched with content as the research progressed and developed along its international itinerary, the Foundation is engaged in several other areas, like the extensive recovery of Nervi's writings, enabling among other things the new edition of the Norton Lectures given by Pier Luigi Nervi at Harvard University in 1962. Other fields of focus are educational activities: in 2018, PLN Project entered a partnership with the Politecnico di Milano, Lecco Campus, inaugurating recently the **Laboratorio Nervi**. The Laboratorio Nervi is also the setting for the activities of the EU-funded **REcube Project**, which the Foundation is currently developing together with 12 European academic and scientific partners. The **Fondation PLN Project** is also committed to the **conservation and rehabilitation of structures by Nervi**, not only in Italy but also on an international level, with the hope of contributing to a scientific awareness and protection of Modernity's architectural heritage, of which the structures by Nervi remain among its highest expressions. Within this framework, the Foundation participated in the creation of the **Conservation Plan of the Stadio Flaminio in Rome**, also funded by **Getty's Keeping It Modern initiative**.

I
- - -
U
- - -
A
- - -
V

The luav research group that took part in the “Keeping It Modern” project belongs to the Dipartimento di Culture del Progetto (DCP). In particular, it represents the Cluster HeModern luav, a form of a research aggregation that carries out multidisciplinary activities on the themes of conservation and enhancement of twentieth century materials and architecture. Specifically, the research activity is aimed at defining the areas, objectives and methods of conservation of this heritage. In addition to university professors and researchers who represent the multiple disciplines of the project, the group also involves Italian and international universities and external stakeholders (Companies / Organizations / Institutions) to share research progress and operational experiences.



The Geomatic Team (A. Spanò, G. Sammartano, G. Patrucco, and S. Perri), part of the Getty “Keeping It Modern” project, is related to the LabG4CH – Laboratory of Geomatics for Cultural Heritage of Architecture and Design (DAD) department - Polytechnic of Turin. The research team, active in geospatial sciences applied to cultural heritage, developed a Digital Twin 3D model of Turin Exhibition Center, integrating 3D metric survey methods and using innovative digital technologies. The goals are oriented to develop advanced approaches facing the challenging complex indoor/outdoor spaces of P.L. Nervi architecture to boost the interaction among 3D documentation methods and their capacity to support analysis and investigation from interdisciplinary points of view.



SCR Piemonte S.p.A. (Società di Committenza Regione Piemonte) is a capital company wholly owned by the Piedmont Region, and was established by Regional Law n. 19 of 6 August 2007. It aims to rationalize public expenditure and to optimize the procedures for selecting public contractors in matters of regional interest, in particular in the fields of infrastructure, transport, telecommunications and health. SCR Piemonte carries out its activity in favor of the Region and of other subjects having center in its territory.

As part of the project, SCR was entrusted with the strategic role of Contracting Station with the function of RUP (Sole Manager of the Procedure).



CMR Center Materials Research is a structure composed of highly qualified technicians able to provide a high-profile scientific contribution to professionals, in the field of restoration and building sectors, accredited by Accredia (accreditation certificate n. 1035, complete test list and updated available on the website www.accredia.it). The laboratory, in particular, is currently the only one in Italy to be accredited, among others, for Thermography according to UNI EN 13187: 2000 (in addition to having a II level PND certified technician for these investigations) and petrographic analyzes on plasters, mortars and stone (UNI 11176: 2006, UNI EN 12407: 2007).



Leonardo Srl is a modern cultural and operative laboratory highly specialized, with all the skills to intervene in terms of preservation, restoration and maintenance of cultural heritage, respecting and improving his history and identity. It operates on cultural heritage from analysis to restoration. The many years of experience along with a continuous theoretical activity and scientific research enable the company to operate in an efficient, innovative way and in full respect of the artworks. Leonardo intervenes both in the planning phase (analysis of materials, conservation status, development of the artifacts) and in the executive phase (restoration, documentation and monitoring over time).



Ecobeton is committed to making the buildings last as long as possible and it wants to do it responsibly and sustainably by sharing the culture of protection and safety. Ecobeton has been dealing with the protection and durability of building constructions for over twenty years. Develop and sells products and systems for the total protection, waterproofing and renewal of concrete and construction materials in general. Thanks to the use of selected raw materials, it offers effective solutions and environmentally friendly through the most advanced and innovative technology in the industry, ensuring absence of toxicity and low environmental impact.



The research team Moni2BSafe (Structural Safety Monitoring Systems) of the Department of Civil and Computer Science Engineering at University of Rome Tor Vergata aims to help improving the safety of buildings and civil engineering structures. By exploiting the capabilities of recent electronics, the miniaturization of components, and the latest developments in sensor technology, the team has designed and realized several devices to pursue the structural safety of structures, especially heritage buildings and monumental structures.



University of Miami is home of the Structures and Materials Laboratory (SML) and the College of Engineering that provide in total about 10,000 ft2 of space for advanced materials characterization and testing. SML is an integrated educational, research and testing service laboratory dedicated to conducting applied and fundamental investigations through experimentation and analysis of construction materials and structures. Since 2012, SML has been an ISO 17025 certified test laboratory accredited by the International Accreditation Service. SML has conducted work for over a hundred different corporations from around the globe.



Buzzi Unicem S.p.A. dedicates particular attention to applied research through continuous, extensive experimental activities, seeking potential innovations for both the production process and the products. To this end, the company participates as an industry partner in national and international research projects, helping to develop new materials and technology and to create a network of knowledge with structures of excellence within the field of scientific research.



R3C is the first Italian research centre with specific tasks to promote adapting and resilient strategies to address natural and human-related risks, ensuring territorial and cultural heritage safety. R3C through an interdisciplinary research methodology aims to study environmental and socioeconomic vulnerabilities of territorial systems, offering resilient models and solutions to support institutions and local communities in addressing the global transition challenges. R3C's target is to achieve Goal 11 "Sustainable Cities and Communities" and Goal 13 "Climate Action" of the 2030 United Nations Agenda, moving toward new territorial governance models.

Foreword of the Rector of the Politecnico di Torino, prof. Guido Saracco

The Turin Exhibition complex, which contains masterpieces by Pier Luigi Nervi, Ettore Sottsass and Riccardo Morandi, is among the architectural jewels of Modern Turin. Until just a few years ago, the risk that this abandoned ensemble of remarkable architectures could remain in a sort of “limbo” was very real. This changed when the Politecnico endorsed the idea to create a “Knowledge Campus” including the Faculty of Architecture, with the hope that a way could be found to extend the intervention to the whole complex, restoring Nervi’s magnificent halls.

On July 18, 2019, the Getty Foundation announced the 2019 grantees of the Keeping It Modern initiative, which included the Torino Esposizioni halls designed and built by Pier Luigi Nervi. This marked the beginning of the research project dedicated to the Turin Exhibition Center conservation plan. The funds bestowed by the Getty Foundation supported a multidisciplinary work involving Italian, European and US researchers led by the Politecnico di Torino and coordinated by Professor Rosario Ceravolo. The scientific work has been carried out with the support of the City of Turin, owner of the complex, and Scr Piemonte Spa, the contracting authority responsible for managing the interventions on the building financed with the remaining 2006 Olympic funds, as well as of the Pier Luigi Nervi Project association, which has been involved in the protection of the works of the engineer since 2008. The research has been led by the Department of Structural, Geotechnical and Building Engineering of the Politecnico di Torino. Many of the members of the working group were young researchers from our PhD in Architectural and Landscape Heritage.

This huge effort supported by the Keeping It Modern initiative has materialized in the impressive research work presented in this volume, completed by a conservation plan. What was a dream is starting to become a reality: the economic commitment of the City of Turin has arrived because of the support of the Complementary Fund to the National Recovery and Resilience Plan, but also thanks to the plan to reuse a part of the complex for educational and cultural activities of the Politecnico.

I can therefore only be grateful to the Getty Foundation for having launched this successful initiative and salute the researchers of the Politecnico, from both the Department of Structural, Geotechnical and Building Engineering and the Department of Architecture and Design, and all the partners involved in the project for having provided us with this indispensable conservation and management tool.

Foreword of the President Fondation PLN Project, ing. Marco Nervi

Torino Esposizioni was completed in time for the annual Salone Internazionale dell'Automobile in September 1948. Its graceful, light roof set a new standard for concrete construction. As important as the engineering and construction achievement was the architecturally evocative space created by the system. The fine grain produced by the repetitive modules is emphasized by the pans' end diaphragms and well-proportioned skylights, creating an insistent but inflected rhythm that breaks the awesome size of the span down into comfortable scale. The hybrid static nature of the arch beams is made clear by the gradual shallowing of the roof pans as they approach the pin-like connections at the arches' springing points, a detail that is subtle yet unmistakable in its visual propriety. The gathering "fans" and buttresses are proportionated in a way that relates the exhibition module of the floor to the construction module of the roof. The graceful curves and tapers that delineate these supporting elements all serve to integrate three separate systems -buttresses, fans, and pans- into a coherent, almost narrative whole. Such detailing serves to reveal the performance of the overall system while also making clear the processes by which it was made, all of this in a system regulated by a keen sense of overall proportion that relates part to whole, particular in the thrusting buttresses. That the entire room is drenched with daylight from the windows cast into the pans overhead punctuates the scale and grain of the roof while making the entire structure seem impossibly lightweight; the combination of structural truth with this sense of sculptural expression and nimble buoyancy is both satisfying and astonishing.

This passionate description of the Torino Esposizioni building given by Thomas Leslie in his 2017 monograph about the work of Pier Luigi Nervi truly reflects the complex marvel of this structure. Almost 75 years after its inauguration, this articulated architectural organism is today in need of an attentive restoration and waits for an updated and respectful reuse, like so many of the works created by this Modern master builder. Scattered between his Italian homeland, Europe, the US and Australia, the grand legacy of the buildings imagined and created by Pier Luigi Nervi is symbolic of the excellence of

technique and the art of construction. It is also emblematic of the complexity involved in the conservation, restoration and reuse of the great works of structural engineering architecture. The reasons are not solely connected with a reduction or loss of physical integrity and serviceability (an issue of material and technical fragility) but also, and sometimes prevalently, with technological change, economic demand and market constraints, associated with the growth and modification of social and cultural climate.

Since its creation in 2008, our organization has been committed to the conservation and rehabilitation of structures by Nervi, not only in Italy but also on an international level, with the hope of contributing to a scientific awareness and protection of Modernity's architectural heritage. Within this framework, our Foundation participated in the creation of the Conservation Plan of the Stadio Flaminio in Rome, funded by the Keeping It Modern initiative.

This research has also been developed thanks to the generous contribution of the Keeping It Modern international Grant promoted by the Getty Foundation – one of the most prestigious international institutions supporting the arts, architecture, and conservation. The Conservation Plan of Torino Esposizioni was drawn up thanks to the collaboration of research teams, local authorities and partners such as laboratories and industrial partners.

In later years, my grandfather himself remembered the creation of Torino Esposizioni as a challenge "of extreme static, constructional, and architectural interest" which he confronted "by exploiting all technical possibilities known to me and by using all the care and aesthetic sensitivity of which I was capable".

Today this study is honoring the legacy of Pier Luigi Nervi's commitment by tracing the way for the sensitive regeneration of this iconic building which is part of the identity of the City of Turin, as well as of the story of the Italian architectural Engineering. We are grateful to all who have contributed to this effort.

Foreword of the Director of Public Works S.C.R. Piedmont region commissioning company, arch. Sergio Manto

In 2014, the City of Turin and the Politecnico di Torino signed a Memorandum for the reuse and conservation of the Turin Exhibition Center, to be configured not only as an architectural project, but as an important part of the city's identity of Turin: a project for the re-functionalisation, development and restoration of a public and cultural space, integrating the creation of the new Civic Library, redesigned with reference to the most advanced European models, with the training and advanced research activities of the Politecnico, in close relationship with the Valentino park and the Po river.

As part of the reuse and conservation of the pavilions designed by Luigi Nervi, the Piedmont Region Procuring Company (SCR) was entrusted with the strategic role of Contracting Station in order to express that type of planning aimed at achieving these targets.

The forms of commissioning structured as SCR, with "specialized professionals" to support the project manager, have the advantage of tracing channels of communication between the operators of the "construction process", enhancing the quality of the respective services (design, execution and management), so as to outline a virtuous path of a highly proactive and innovative nature in which, then, all the other partners are called to measure themselves and to plan and control the production processes, in the time span that goes from planning to design to implementation to maintenance and management until the end of its life cycle.

Along this path, significant public resources are managed, different skills come together and different procedures and tools are applied, all factors competing towards a single objective: to restore the functionality of a building complex of incomparable architectural value, preserving its original architectural characteristics and enhancing it through the feasibility for a fundamental reuse for the city and at the center of an urban transformation destined to completely change the face and public use of a significant part of the city along the Po river axis.

In 2015, a feasibility study for the reuse of the Torino Esposizioni complex aimed at defining the interventions and resources necessary for its redevelopment. In order to evaluate the residual life of the buildings in the Center and the costs of any structural and system restoration, the need emerged to carry out a specific research program concerning structural investigations. Therefore, the opportunity was taken of the project already started in 2019 by the Politecnico di Torino with the Getty Foundation of Los Angeles to extend the aforementioned project, commissioning a series of specific investigations and surveys, functional not only to deepen the knowledge of the building, but to better calibrate the planned interventions in order to optimize future execution methods and costs.

The aforementioned tests and fact-finding investigations envisaged for the evaluation of the structural safety levels of the two Nervi halls were closely coordinated with the specialized studies and investigations envisaged by the Getty project and provided a fundamental basis for the definition of the technical-economic feasibility project currently in the drafting phase which will be placed, in the coming months, as a basis for the tender for the assignment of the executive design and construction of the works by SCR Piemonte S.p.A., in agreement with the City of Turin.

On the basis of the aforementioned Feasibility Study, the City of Turin presented a proposal to the Ministry of Culture ("Turin, its park and its river: memory and future"), aimed at the redevelopment of part of the river axis Po, which sees as its main and overall activity the regeneration of the Parco del Valentino and the reuse of various buildings located within it as well as the restoration of the river navigation service as a tourist attraction and pole of higher education. The overall intervention was found to be the recipient of funding amounting to 100,000,000.00 euros from the resources of the Complementary Fund to the National Recovery and Resilience Plan(PNRR), and provides for the enhancement and recovery of public green areas, the restoration of river navigation, the restoration of the Borgo Medievale, the construction of the

new central Civic Library and the adjoining cultural center as well as the restructuring of the Teatro Nuovo aimed at allowing theatrical and cultural activities inside. In addition to this fund, Agenzia Torino 2006, in agreement with the 20 March 2006 Foundation, has allocated a loan of approximately 7 million/€ from the funds of Law 65/2012.

In order to ensure the effective and timely implementation of the interventions, in the first months of 2022 the City of Turin requested the availability of SCR to assume the role of Contracting Authority for the implementation of the aforementioned interventions, also assigning it the role of Manager of the Procedure, Project Manager, as well as the overall management of the procedures relating to the design and construction of the works, in all phases, in compliance with current legislation on Public Contracts.

SCR promptly launched the activities by carrying out the tenders for the design and relative verification of the interventions falling within the Agreement stipulated with the City of Turin and to date - November 2022 - all the tenders for engineering services have already been awarded involving high-level professionals, as listed below.

CONSTRUCTION OF THE CIVIC LIBRARY AND REDEVELOPMENT OF THE NEW THEATRE

RTP: ICIS Engineering S.r.l. (Agent) - Arch. Rafael MONEO - ISOLARCHITETTI S.r.l. - Engineer Giovanni Battista QUIRICO - ONLECO S.r.l. - MCM ENGINEERING S.r.l.

RESTORATION OF THE VALENTINO PARK

R.T.P.: LAND Italy (agent) - Recchi Engineering S.r.l. - GAE Engineering S.r.l. - BMS Progetti S.r.l. - TRA S.r.l. - ICIS Engineering S.r.l.

RESTORATION OF THE BORGO MEDIEVALE

RTP: ISOLARCHITETTI S.r.l. (Agent) - Arch. Giovanni DURBIANO - Alessandro ARMANDO - SINTECNA S.r.l. - NICOLA RESTAURI - MCM ENGINEERING S.r.l.

S.C.R. Piedmont SpA will complete the works tenders in 2023 and then start the construction sites in the first months of 2024 and conclude them by 2026.

Written with the assistance of colleagues Dr. Davide Ceraso and Eng. Claudio Trinciati

Torino, November 10th 2022

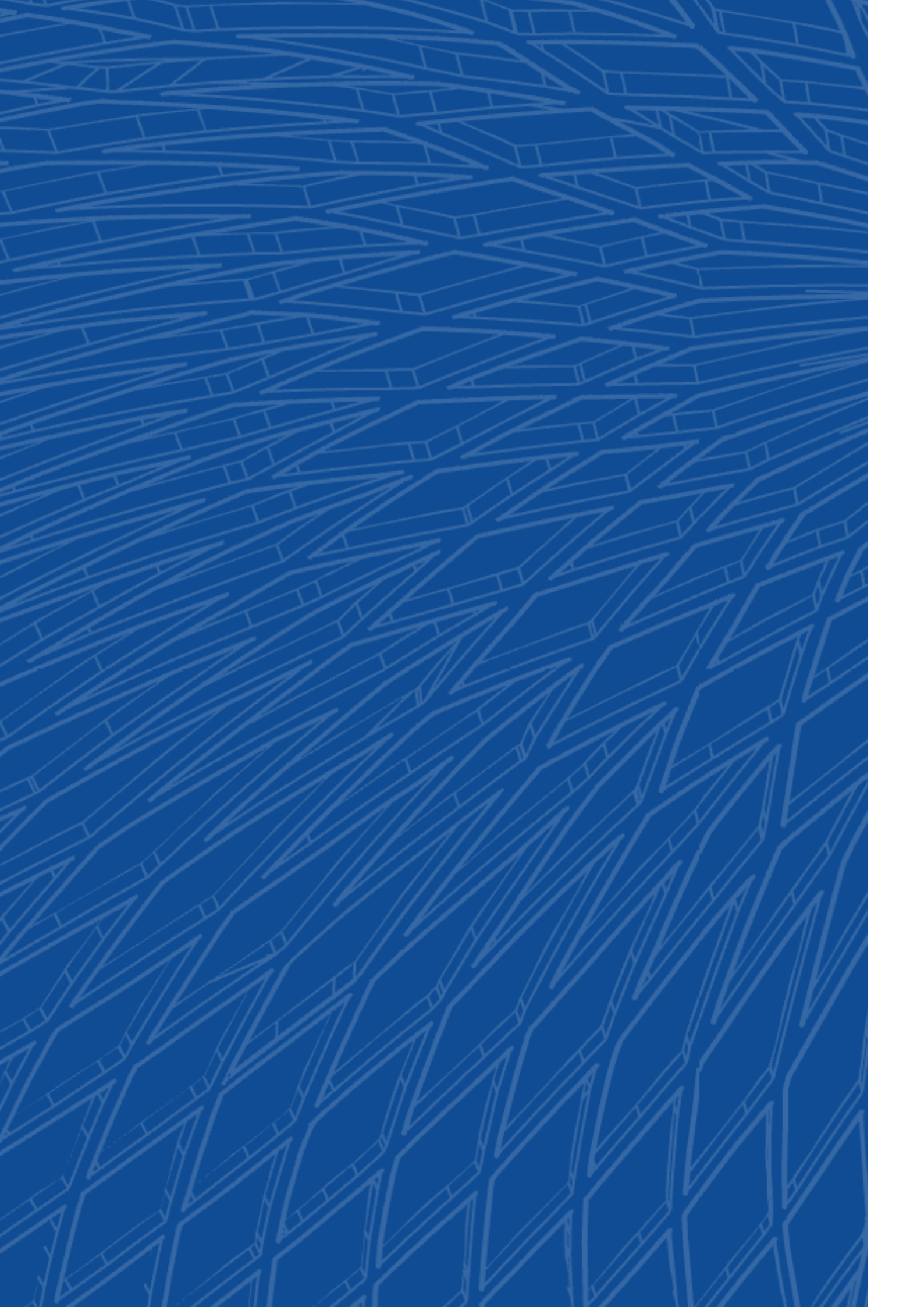

Contents

1	PROJECT DESCRIPTION: OBJECTIVES, METHODOLOGY AND WORK PLAN	19
1a	Why it is important to analyze and preserve the structures built by Pier Luigi Nervi in Turin Exhibition Center	19
1a.1	Background	19
1a.2	Why the Turin Exhibition Center	19
1a.3	Key elements of the project	20
1b	The building	21
1b.1	General information	21
1b.2	Ownership and use of the building	25
1c	Work plan	28
1c.1	Conservation and reuse issues	28
1c.2	Reference deontological standards	29
1c.3	Activities of the three research teams and dissemination team	31
1d	References	35
2	DOCUMENTATION FOR KNOWLEDGE AND CONSERVATION	38
2a	Historical Overview	38
2a.1	Urban context history 1911-1939	39
2a.2	The birth of the building 1947-1950	41
2a.3	The addition of Hall C 1950	46
2a.4	The patents used by Pier Luigi Nervi in the building	49
2a.5	The life of the halls: enlargement and transformations 1954-1959	50
2a.6	The reinvention of ferrocement by Pier Luigi Nervi	52
2a.7	The life of the halls 1960-2006	54
2b	Archives and data sources	55
2b.1	Protection status	55
2b.2	Archives	55
2c	Construction history and elements coding	59
2c.1	Introduction	59
2c.2	Construction phases	59
2c.2.1	The "Sistema Nervi"	60
2c.2.2	Synthesis, analysis and representation methodology	61
2c.3	Transformations related to use	67
2c.3.1	From the 2006 Olympics to abandonment	68
2c.4	Deconstruction	71
2c.4.1	Approach and criticality methodology	71
2c.4.2	The elements in traditional casting	72
2c.4.3	The prefabricated elements	72
2c.4.4	Connection castings	74
2c.5	Overall key	74
2c.6	Conclusions	74
2c.7	Bibliography	75

2d	Structural conception and design	76
2d.1	Introduction	76
2d.2	Hall B	77
2d.2.1	Undulating vault	79
2d.2.2	Fanned elements	85
2d.2.3	Inclined pillars	87
2d.2.4	Front tympanum	88
2d.2.5	Apse tympanum	90
2d.2.6	Apse	91
2d.2.7	Slabs	94
2d.3	Hall C	95
2d.3.1	Identification of the main structural elements	96
2d.4	Nervi's patents used in the Turin Exhibition Center	102
2d.5	Bibliography	104
3	3D METRIC DOCUMENTATION USING GEOMATIC METHODS	106
3a	Integrated and multi-sensor 3D metric survey	107
3a.1	Aims and strategies of the digitization project	107
3a.2	Rapid Mapping	108
3a.3	3D metric survey planning	110
3a.4	Topographical control network	113
3a.5	UAV Photogrammetric survey	117
3a.6	Laser Scanning survey	120
3a.7	Completion of the survey by MMS integration	124
3a.8	ZEB Revo RT by GeoSLAM	124
3a.8	Integration of point clouds	128
3a.9	Close range photogrammetric survey of non-destructive investigations	128
3a.10	Representation of architectural drawings with integrated orthophotos	134
3b	Geometric interpretation of P.L. Nervi surfaces	141
3b.1	Geometric characterization of structural elements of the vaults and arches of Halls B and C	142
3b.2	Study of the geometry at the base of the ribs of the apse of Hall B	150
3c	Point clouds and surface analyses to detect anomalies	154
3c.1	Alterations of the horizontal surfaces of the roofs.	154
3c.2	Cracks in the ceiling of the basement of Hall B	156
3c.3	The foundations and the grid of pillars of Hall C	158
3c.4	Shape anomalies of the SAP vault in Hall B	161
3c.5	Morphology of the envelope shape via intrados/extrados integration and comparisons with historic design drawings. Halls C and B.	162
4	PREPARATORY ACTIVITIES FOR CONSERVATION	168
4a	Problems, limitations and opportunities in the use of the building	168
4a.1	Current issues with the use of the property	168
4a.2	Alterations to the original fabric and safety implications	172
4a.3	A new course for the Turin Exhibition Center?	174
4b	Direct analysis of the state of conservation	178
4b.1	Direct analysis	178
4b.2	Material analysis	178
4b.2.1	Identification and location of materials	178
4b.2.2	Characterization of the constructive element	181
4b.2.3	Keys for material specifications	181

4b.2.4	Characterization of cement materials	183
4b.3	Alteration and decay analysis	184
4b.3.1	Identification and location of forms of alteration and decay	193
4b.3.2	Keys for the identification of forms of alteration and decay	193
4b.3.3	Identification of the forms of decay for cement materials	193
4b.4	Summary sheets	194
4b.5	Bibliography	195
4c	Structural safety requirements and checks	204
4c.1	Standards for a structural safety assessment of architectural heritage	204
4c.2	Preliminary structural and seismic analyses	208
5	STRUCTURAL AND SEISMIC ASSESSMENT	214
5a	On-site tests	214
5a.1	Introduction	214
5a.2	Test instruments	215
5a.3	Testing campaign on Hall B	215
5a.3.1	Corings	217
5a.3.2	Ultrasonic tests	221
5a.3.3	Rebound test and index	226
5a.3.4	Structural survey: rebars	227
5a.3.5	Corrosion tests	237
5a.3.6	Acoustic emission tests	254
5a.4	Testing campaign on Hall C	258
5a.4.1	Corings	263
5a.4.2	Ultrasonic tests	265
5a.4.3	Rebound test	268
5a.4.4	Structural survey: rebars	269
5a.4.5	Ferrocement elements	280
5a.4.6	Corrosion tests	282
5a.4.7	Thermographic investigations	307
5.b	Laboratory tests	312
5b.1	Introduction	312
5b.2	SONREB method	312
5b.2.1	Compressive test	313
5b.2.2	Tensile tests on rebar	314
5b.2.3	Granulometry	315
5b.2.4	Resistance tests on cements	316
5b.3	Laboratory test certificates for years 1952-1954, engineering firm Nervi & Bartoli for Turin Exhibition Center - Extension Hall B	317
5b.3.1	Compressive tests	317
5b.3.2	Granulometry	318
5b.3.3	Resistance tests on cements	319
5b.3.4	Compressive tests performed on specimens subjected to the action of frost and on specimens cured in a normal environment	320
5b.4	Laboratory Test Certificates for years 1949-1950, construction company of Nervi & Bartoli engineers for Turin Exhibition Center – Hall C	322
5b.4.1	Compressive tests	323
5b.4.2	Resistance Tests on cements	324
5b.5	Tests on cylindrical concrete specimens	324
5b.5.1	Hall B	324
5b.5.2	Hall C	327
5b.6	Chemical-physical analysis	330
5b.6.1	Hall B	330

5b.6.2	Hall C	345
5b.7	SONREB	354
5b.7.1	Hall B	354
5b.7.2	Hall C	358
5b.8	Discussion on the results	360
5b.8.1	Hall B	360
5b.8.2	Hall C	362
5b.9	Bibliography	365
5c	FE model corroboration process	366
5c.1	Methodology	366
5c.1.1	Preliminary data collection	366
5c.1.2	Preliminary evaluation of static condition	368
5c.1.3	Preliminary evaluation of the static conditions	368
5c.2	Application	369
5c.2.1	Hall C: building information modelling process	369
5c.2.2	FE model corroboration	370
5c.2.3	Static analysis	371
5c.2.4	Eigenvalue/eigenvector analysis	385
5c.3	Conclusive remarks	388
6	POLYCHROMY OF THE TURIN EXHIBITION CENTER HALLS	390
6a	20th century architecture between white myth and polychromy	390
6b	Polychromies of the Turin Exhibition Center	393
6c	Analysis of the polychromies	397
6d	Conservation issues and intervention	422
6e	Bibliography	422
7	FERROCEMENT: EXPERIMENTATION ON MATERIALS AND MODELS	424
7a	Context: ferrocemento	425
7a.1	Introduction	425
7a.2	Ferrocement Literature Review	426
7b	Objectives	428
7c	Methodology	429
7c.1	Material Analysis & Selection	429
7c.2	Small Mock-ups	437
7c.3	Testing Matrix Program	441
7c.4	Treatment Selections	442
7c.5	Accelerated Weathering Cycles	442
7c.6	Assessment Testing – Before, During and After	443
7c.7	1:1 Mock-up	446
7d	Results & outcomes	449
8	DIGITAL TWINS FOR CONSERVATION	452
8a	Digital twin strategy	452
8a.1	As-Built modelling approaches.	453
8a.2	Data integration and interpretation in a multidisciplinary context: HBIM as multi-contents archive	470

8b	Digital twins for structural diagnosis	476
8b.1	Methodology	476
8b.1.1	The role of modelling	476
8b.1.2	Corroboration of numerical models with experimental data	478
8b.1.3	Dynamic characterization	478
8b.2	Application to Hall C of the Turin Exhibition Center	480
8b.2.1	Dynamic tests	481
8b.2.2	System identification and model updating	482
8b.3	Application to Hall B of the Turin Exhibition Center	487
8b.3.1	Dynamic tests	487
8b.3.2	System identification and model updating	489
8b.4	Conclusive remarks	493
8c	Permanent monitoring strategies	494
8c.1	Introduction	494
8c.2	The world of permanent structural health monitoring	495
8c.3	A basic long-term structural health monitoring system	496
8c.4	The long-term structural health monitoring system installed at the Turin exhibition center	498
8c.4.1	Measurement frequency	501
8c.4.2	Data transmission	502
8c.4.3	Power supply	502
8c.4.4	Displacements and accelerations	502
8c.5	A proposal for a permanent structural health monitoring system	503
9	CONSERVATION MANAGEMENT PLAN	506
9a	Hints and conservation strategies	506
9a.1	Introduction	506
9a.1.1	Italian Legislation	506
9a.1.2	Critical Issues	507
9a.2	Conservation plan: structure of the tables	509
9a.3	Bibliography	509
9b	Structural and seismic safety measures for conservation	511
9b.1	Premises	511
9b.2	Structural and seismic assessment of Hall B	511
9b.2.2	Final notes on the structural and seismic improvement of Hall B	515
9b.3	Structural and seismic assessment of Hall C	515
9b.3.1	Critical structural elements and safety measures	517
9c	Identification of the constructive elements	518
9d	Conclusions	581
10	DISSEMINATION	583
10a	Architecture tours	585
10b	Virtual tours	586
10c	Website and social medias	587
10d	Scientific dissemination	588
10e	Publications	592

8 Digital twins for conservation

8a Digital twin strategy

Giacomo Patrucco¹, Stefano Perri¹, Giulia Sammartano^{1,2}, Antonia Spanò^{1,2}

¹ Politecnico di Torino, Department of Architecture and Design. LabG4CH - Laboratory of Geomatics for cultural Heritage. antonia.spano,giacomo.patrucco,stefano.perri,giulia.sammartano@polito.it

² Politecnico di Torino, FULL – Future Urban Legacies Lab interdepartmental centre

The digital documentation process that was addressed for the knowledge, conservation and management of Pier Luigi Nervi's Turin Exhibition Center reflected the complexity of the object and required an immense effort to develop a novel, holistic approach, tailored on the strong, interdisciplinary nature of the research. The uniqueness of this 20th century concrete heritage site¹ was an opportunity to propose and fully address the meaning and implementation of a Digital Twin.

The generation of a so-called Digital Twin was not merely a visual matter. Although this assumption would seem to be commonly accepted, the real challenge was actually to go beyond the purely geometric content and ensure the partial or full implementation of information enrichment and interoperability².

Digital products represent a crucial basis for geometric modelling and analysis and, more generally, for information recording related to multi-approach investigations. Multiple and combined technologies are adopted nowadays for multi-scale oriented modelling, taking advantage of the contribution of different sensors and data fusion³. The integrated approach proposed in this research started from the assumption that the 3D multi-scale, multi-sensor model played a crucial role in the multiple investigations on the structural assessment of this complex, 20th century, ferrocement architecture and was effective in supporting a structural analysis, based on the achievement of the pre-established goals.

The multi-scale nature of digital models is able to not only twin the physical object, but also store information and record the investigation in order to detect and analyse any deformation

and anomalies, especially from a structural point of view. In fact, a combination of 3D sensing technologies and reality-based modelling strategies also permit advanced generative processes for the 3D mapping of complex geometries and information⁴.

The contribution proposed an integrated approach to generate an n-D enriched model, also called a digital twin, able to support the interdisciplinary investigation process conducted on the site, together with structural engineers, restorers and conservation experts.

Therefore, the process description can initially be divided into the model generation and the model enrichment with data integration, even though the implication remains that the two aspects are not only complementary, but also equally mutually necessary for supporting the Conservation Management Plan strategy.

As anticipated from the beginning, the project developments of the following stages took advantage of many reflections reported herein. The importance of implementing a rapid, high-scale strategy, based on the integration of LiDAR, a photogrammetric approach and topographic measures for the multi-temporal documentation of diagnostic investigation tests was evident in the creation of the multi-scale digital twin of the structure. The 3D data and points were organized in NURBS (Non Uniform Rational Basis-Splines)⁵ and could be stored in their spatial relation with the 3D model generated with the as-built approach by the HBIM paradigm⁶. However, it was necessary to explore the potential of metric and radiometric information management, for which the BIM

1 Cádiz Document, 2021; Madrid-New Delhi Document, 2017.

2 Shahat et al. 2021

3 Scianna & La Guardia, 2019.

4 Banfi, 2020.

5 NURBS are mathematical representations of geometric curves or surfaces used in computer graphics, they are a general definition of B-Splines or Bezier curves.

6 Oreni et al. 2014.

space still had bottlenecks. The 3D modelling procedures were designed to create a database of different kinds of information, able to accomplish different purposes: on the one hand, to support 3D finite-element analyses for in-depth knowledge of the architectural elements, which had been acquired and modelled; on the other hand, to serve as a repository of information connected not only to the architectural object, but

also to the other different aspects, including those related to the knowledge processes. The NURBS model was created to represent not only the geometric features of the basement under investigation, but also to map the different analyses, which had been carried out during the documentation campaign⁷.

8a.1 As-Built modelling approaches.

Considering the highly interdisciplinary studies carried out as part of the Turin Exhibition Center conservation project, highlighted in Section 3.1, it was clearly important to provide a common spatial background to relate and improve the interpretation of the results obtained from the multidisciplinary research and investigations⁸. This was true considering not only the approach to informative modelling, but also the opportunity of exploring, connecting, managing, and querying heterogeneous data stored in the 3D database, aimed at creating an information archive for the diagnostic tests and results of the completed investigations. The HBIM paradigm was explored and expanded in order to fulfil the multi-source data requirements. It set out to adapt the consolidated reverse-modelling processes from scan-to-BIM from static and advanced mobile mapping technologies, aimed at point cloud acquisition towards such crucial, spatial geometries for double curvature, structural elements (e.g. the arches of Hall C, the dome of the apse and the vault of Hall B, etc.). The main objective of the study was to evaluate the role of 3D documentation based on an As-Built modelling strategy, oriented towards the generation of the so-called Digital Twins as an essential and fundamental phase of the diagnosis and conservation project. For this reason, a prior determination of

the following modelling approach was proposed:

- Object interpretation
- Data optimization (registration, filtering and semantic segmentation).
- Surface approximation (by means of NURBS modelling).

Therefore, the acquired point clouds, generated according to the image- and range-based methods and strategies described in the previous sections, were pre-processed in order to optimise the primary data to be used as the starting point for the subsequent modelling operations. After the preliminary survey phases described in Section 3.1, during which the spatial data was acquired and recorded in a common reference system, the point clouds were filtered using automatic, semi-automatic or manual procedures, in order to optimise acquired data manageability by reducing the redundant points and deleting the possible outliers. After these operations, a semantic segmentation was used to identify and classify the points belonging to the different structural elements (Figure 8a 1.1) described in Section 2. This procedure was crucial, since it enabled not only the structural elements analysed to be correctly modelled geometrically, but also a preliminary semantic content to be introduced.

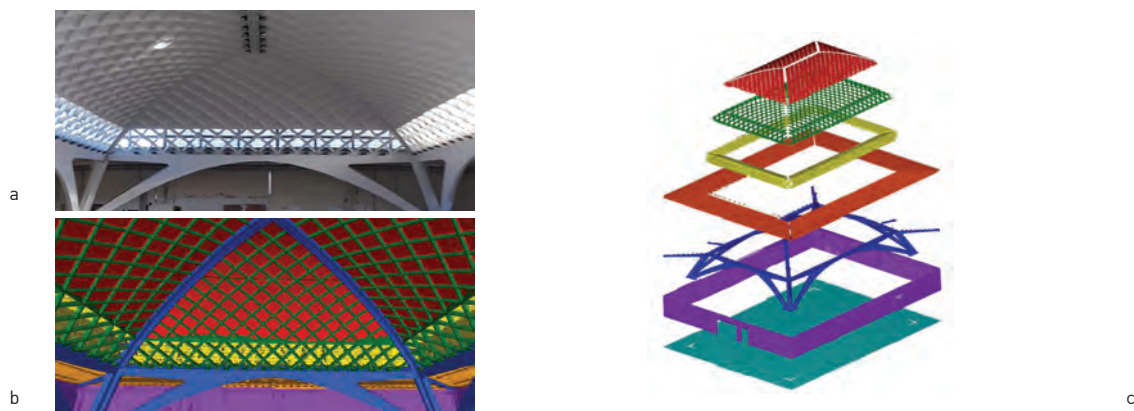

8a1.1: (a) Hall C; (b) the optimized and segmented LiDAR point cloud after the classification processes; (c) split axonometry of the segmented point cloud portions.

⁷ Sammartano et al. 2021.

⁸ Mandelli et al. 2017.

The final goal was the parametric modelling generation based on different Level of Detail Objects (NURBS double curvature surfaces and for ferrocement structures). The aim was to optimise and to topologize the unstructured, primary data (in the form of point clouds and polygonal models) to generate 3D surfaces and volumes suitable for information hosting purposes⁹. As part of this work, 3 levels of complexity in the as-built method could be identified, in accordance with the typical parametric modelling approach:

Planar surface interpolation (Figure 8a 1.2).

In this case, a similar approach was adopted to model the walls, the planar ceilings and, generally, all the surfaces that could be approximated with a planar geometry (e.g. faces of

the rectangular or square cross-section pillars). The first step of this modelling strategy consisted in segmenting the primary data – the point clouds – to isolate all the approximately planar surfaces. Subsequently, a best fitting planar surface for each segmented point cloud was interpolated, following a least squares estimation method. During this step, it was crucial to verify the discrepancies between the primary data and the surfaces derived from the least squares estimation. The aim was to validate the interpolated data and to verify whether the deviation was acceptable for the intended purposes, considering the pre-determined survey tolerance and precision that had to fit the scale of the representation.

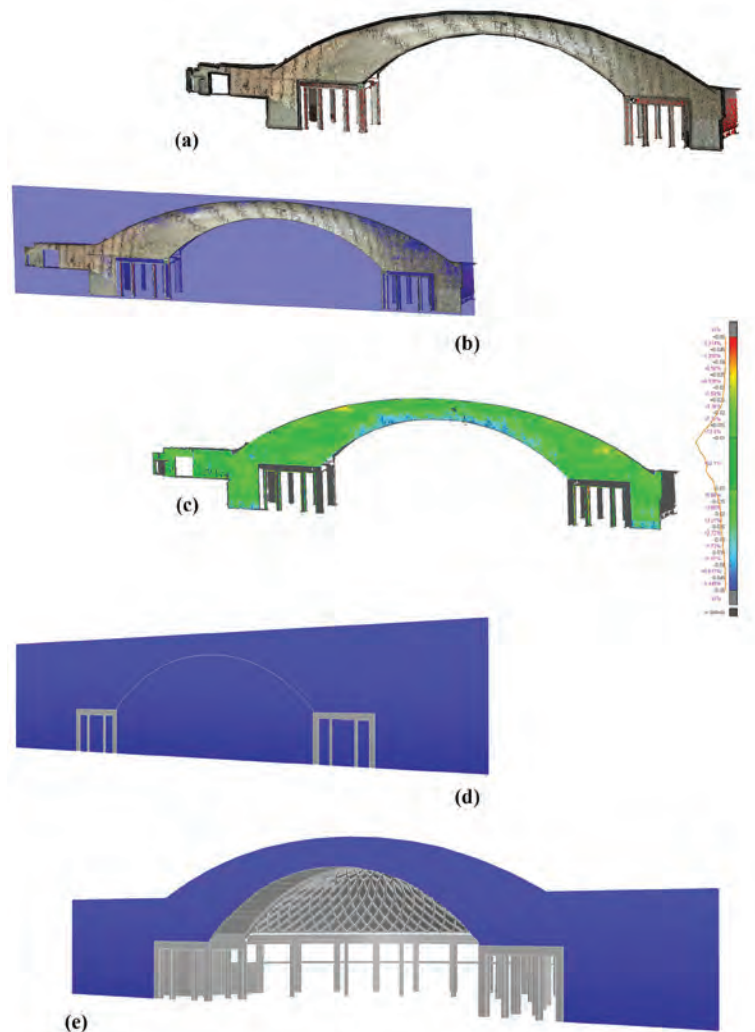

8a1.2: Operational workflow for the least squares interpolation of the planar surfaces. a) Identification of the portion of the point cloud elements approximable to a planar surface. b) Interpolated plane from the surface under consideration. c) Discrepancy analyses between the primary data (point cloud) and interpolated plane (the observed discrepancy is less than 2 cm for 80% of the surface under consideration). d) Visualisation of the interpolated plane on the Rhinoceros platform. e) NURBS modelling from the interpolated plane.

Recognition of generative geometries.

This approach was dealt with in Section 3.2, in order to model the surfaces of the architectural elements that were approximable to a primitive geometry. This strategy enabled the dome to be modelled of the Hall B apse, which is similar to a portion of a sphere, as can be seen in Section 3.2.2, which studied the geometry of the domed structure in more depth. In this case, the modelling approach followed was as follows: the point cloud was segmented – using a semi-automatic method exploiting the direction of the curves and the development

of the analysed portion of the apse's dome – to identify and to separate the intrados of the ribs and the dome surfaces. Therefore, the primitive geometry for each segment – two different, best fitting spheres with a different radius – was interpolated using the least square method, to obtain the surfaces that best suited the acquired point clouds. Figure 3.2.2.4 shows the different phases leading to the NURBS surfaces, whereas Figure 8a1.3 shows the final result of these modelling operations.

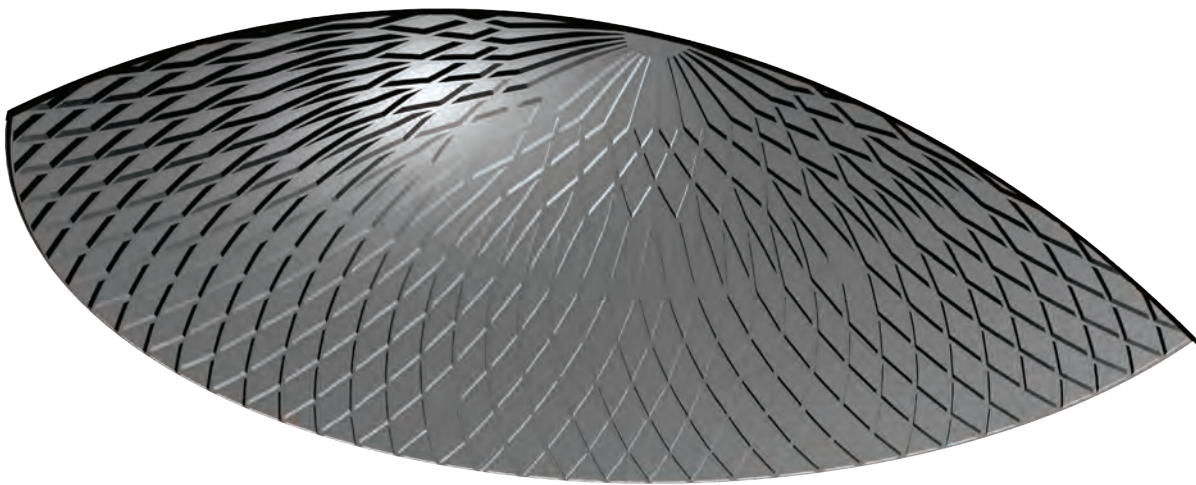

8a1.3: NURBS model of the dome's apse generated following the described workflow.

Reverse modelling.

This strategy is particularly suitable for the 3D reconstruction of complex geometries, when the architectural elements are hardly referable to a primitive geometry. Even though we know that Pier Luigi Nervi highly valued parabolic curves and made extensive use of them, this approach was adopted to model the complex structural elements of the two halls, including the geometrically shaped, ferrocement ceilings (including the double curvature arches of Hall C, the ribbed vault of Hall B, etc.). The profiles (Figure 8a1.4) of the analysed objects were extracted via a sequence of sections in order to model the surfaces of interest, enabling the optimisation of the final 3D model without degrading metric accuracy. In our case, a high-resolution, polygonal model, 3D mesh, generated by means of Delaunay triangulation, was automatically generated from the point cloud. It was used to produce the sections and the profile extraction, in order to optimise the generation of sections by providing a surface model instead of a discontinuous point

cloud that lacked topology. In recent years, new, advanced, modelling tools have been developed and implemented on many platforms¹⁰, enabling accurate NURBS surfaces to be created (Figures 8a 1.5 - 8a 1.6), starting from the extrusion of the extracted profiles. The generated geometries feature millimetre-level deviations from the original, physical model.

With the aim of presenting the modeling strategy in a complete and detailed way and most of all the congruence between the identification of the parts of the model with respect to the general interpretation of the structural conception, we present a table that identifies the individual structural elements modeled by recalling the structural coding, and recalling the type of 3D survey or at which point of the present report, it is possible to find specific information on the analysis and representation strategies adopted. (table 8a. 1)

10 The modelling platform used during this research experience was the well-known software Rhinoceros.

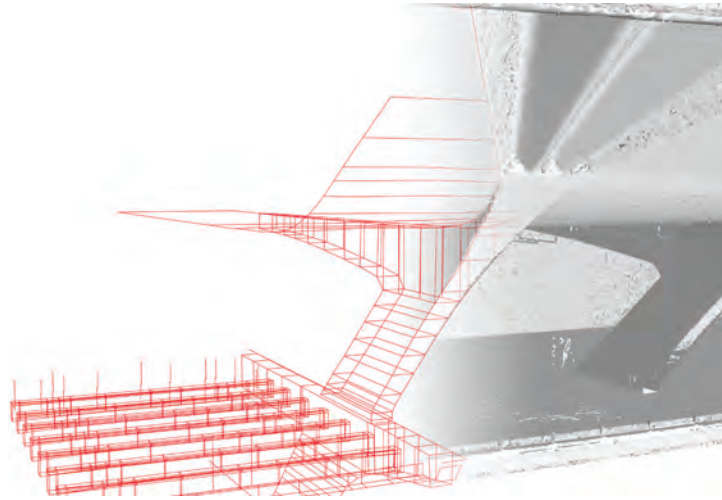

8a1.4: Left, profiles extracted from the sections performed on the 3D mesh. Right, the automatically generated, high-resolution 3D mesh.

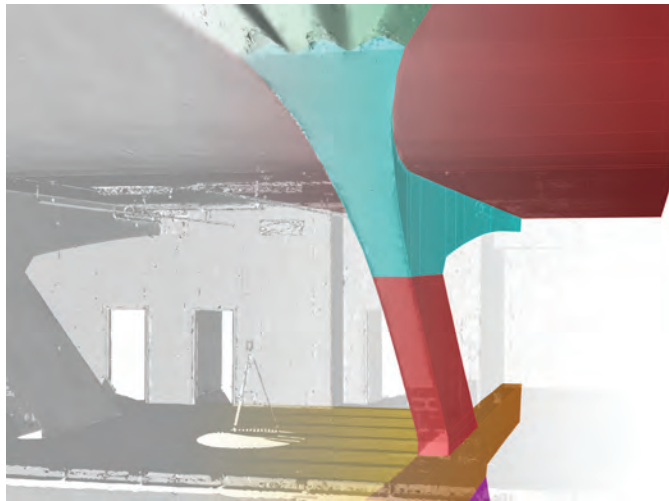

8a1.5: Left, 3D mesh. Right, the NURBS models classified according to the different structural elements.

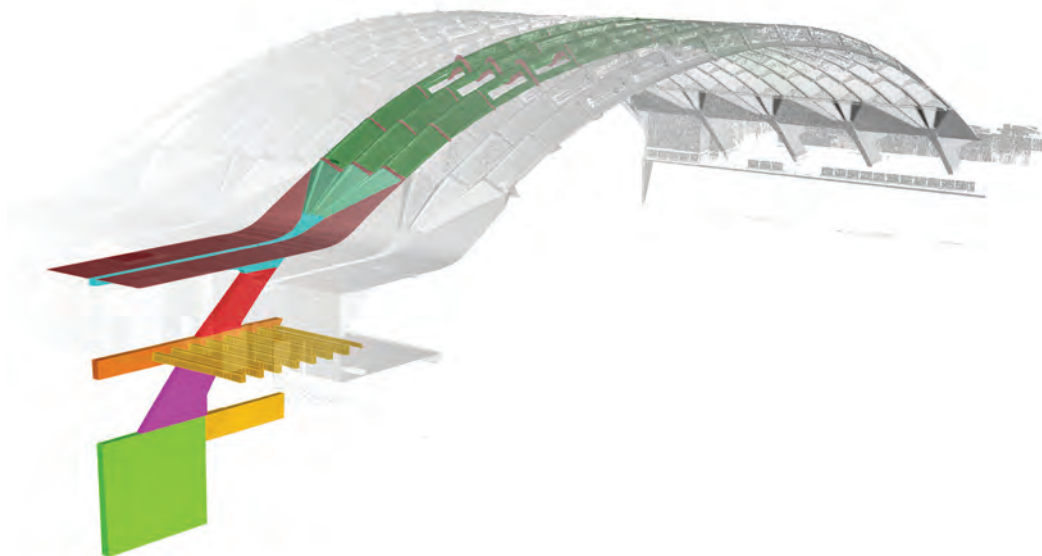

8a1.6: Left, the NURBS models of the elements composing a structural module of Hall B, classified according to the different structural elements. Right, the 3D mesh derived from the LiDAR point cloud.

Table 8a 1: The general scheme of the as built modeling strategy adopted, which is compliant with the structural conception.

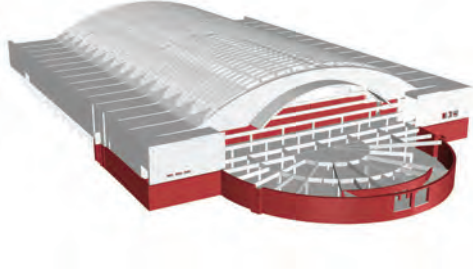
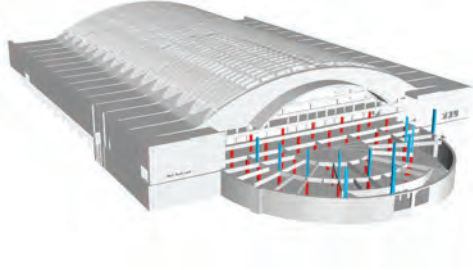
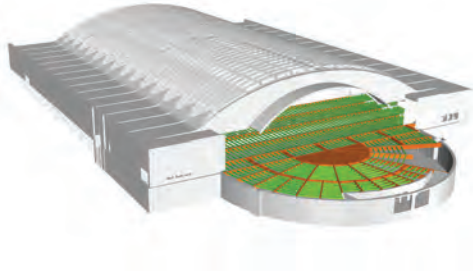
	<ul style="list-style-type: none"> • Identification: Basement floor • Type of modelling: mostly planar surface interpolation • Structural coding 1. Slab lev. - 1 1.1 structure 1.2 flooring • 3D survey and modelling: TLS and SLAM-based MMS (Paragraph 3a. 7). • Panel 6. Plan of the basement floor with the elements of the ceiling project.
	<ul style="list-style-type: none"> • Identification: Pillars of basement floors • Type of modelling: mostly planar surface interpolation • Structural coding: 7.1 Pillars LEV-1 • 3D survey and modelling: TLS (Paragraph 3a. 7). • Panel 6. Plan of the basement floor.
	<ul style="list-style-type: none"> • Identification: Ceiling of the basement floor • Type of modelling: mostly planar surface interpolation • Structural coding: 2. Slab lev 0 • 3D survey and modelling: TLS on samples (Paragraph 3c. 2). • Crack pattern mapping. • Panel 6.1. Plan of the basement floor with analysis of the cracks pattern.

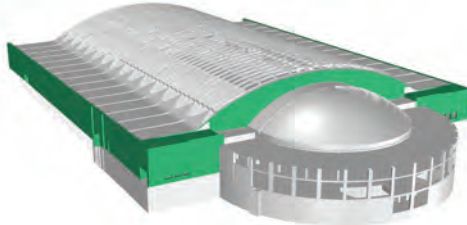

- **Identification:** Perimetral masonries and east gable
- **Type of modelling:** mostly planar surface interpolation
- **Structural coding:**
 - 4. Perimetral masonry
 - 4.1 North Wall
 - 4.2 South Wall
 - 5.1 East Gable
- **3D survey and modelling:**
 - TLS SLAM-based MMS (hand-held scanner)
 - (Paragraph 3a. 6, Hall B, 3a. 7).
 - Panel 4 Ground floor plan.

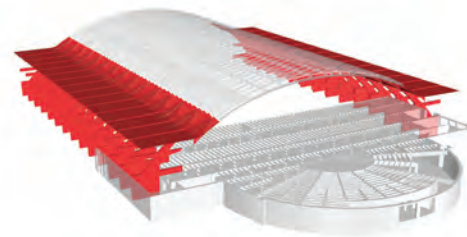

- **Identification:**
 - Large pillars
- **Type of modelling:**
 - Reverse modelling
- **Structural coding:**
 - 6. Large pillars
 - 6.1 North pillars
 - 6.2 South pillars
 - 8.1.1 Balcony roof
- **3D survey and modelling:**
 - Integrated TLS, SLAM-based MMS (hand-held scanner and trolley Swift system) (Paragraphs 3a. 6, 3a. 7).
 - Panels 7, 7.1, 26, 27.
 - Cross sections Hall B.

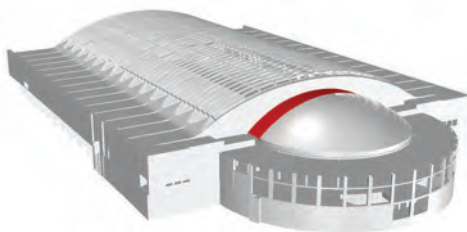

- **Identification:** SAP arch
- **Type of modelling:**
 - Mostly planar surface interpolation
- **Structural coding:**
 - 8.1.5 Big Arch (SAP)
- **3D survey and modelling:**
 - TLS and in-depth study using Stonex F6 SR.
 - Shape anomalies study in 3c. 4.

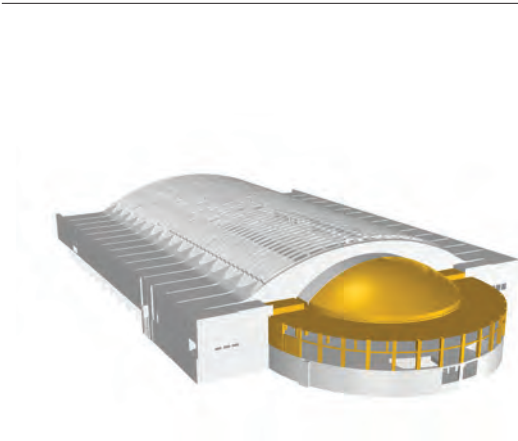

- **Identification:** Apse
- **Type of modelling:** Recognition of generative geometries
- **Structural coding:** 4.3 Perimetral Apse wall
8a. 3 Apse_flat roof
8a. 4 Semi Dome Apse
- **3D survey and modelling:** Integrated TLS and MMS (trolley Swift system). Paragraph 3b. 2.
- Panel 4. Ground floor plan with projected ribs of ceiling.

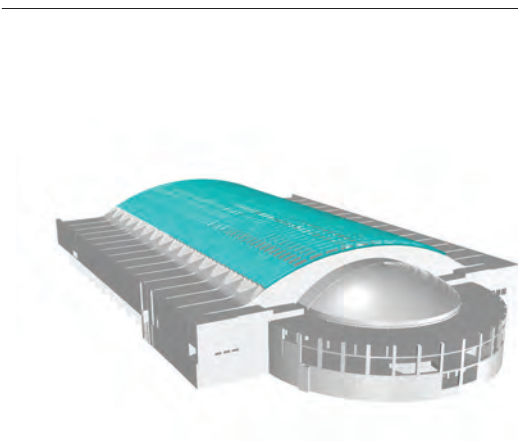

- **Identification:** Central vault
- **Type of modelling:** Reverse modelling.
- **Structural coding:** 8a. 1 Central vault
- **3D survey and modelling:** UAV photogrammetry, TLS, close-range photogrammetry. Paragraph 3a. 9, 3a. 5.
- [Morphology of the envelope]
- Panels: 2. Architectural drawings of the roofs of Hall B;
3. Digital Surface Model (DSM) of the roof of Hall B.
4. Ground floor plan 2.



- **Identification:** P12 involving related elements and connected others
- **Type of modelling:** Reverse modelling

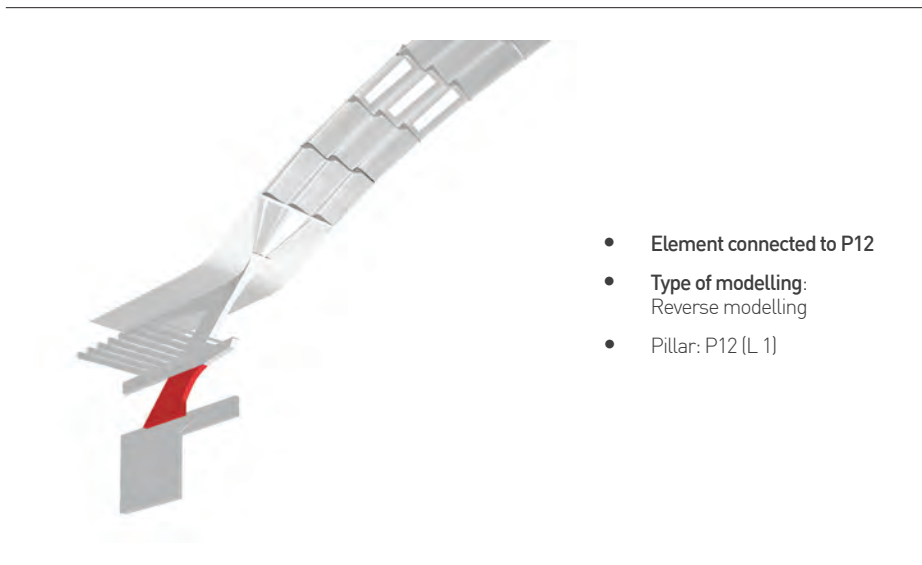
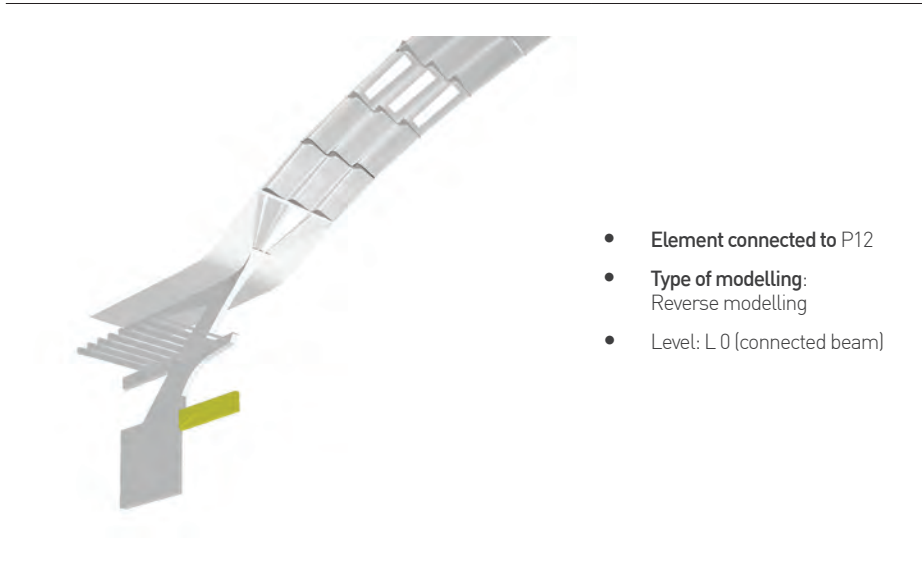
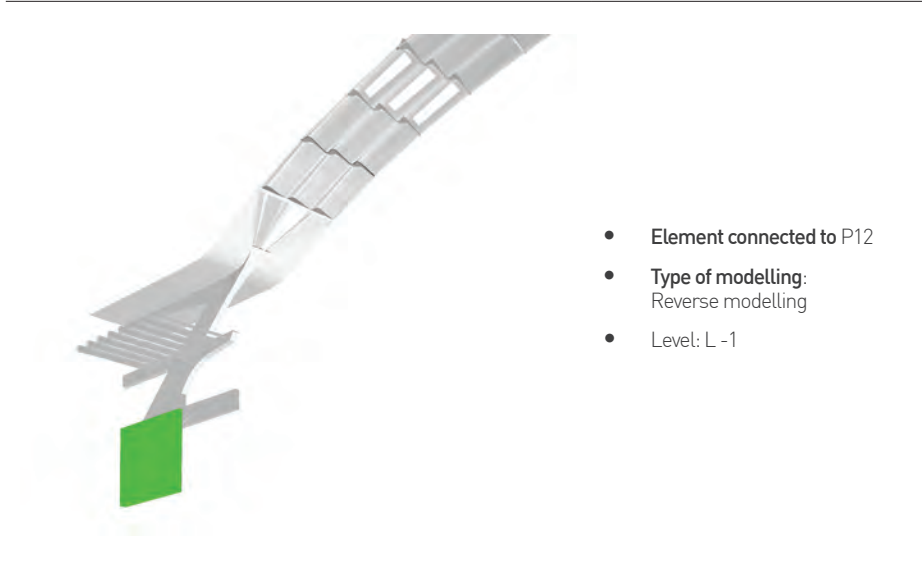

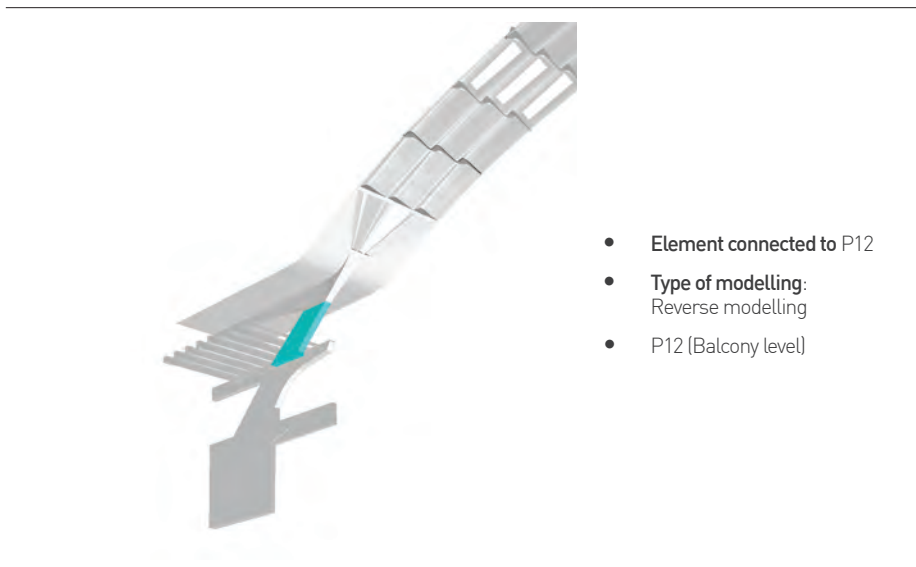
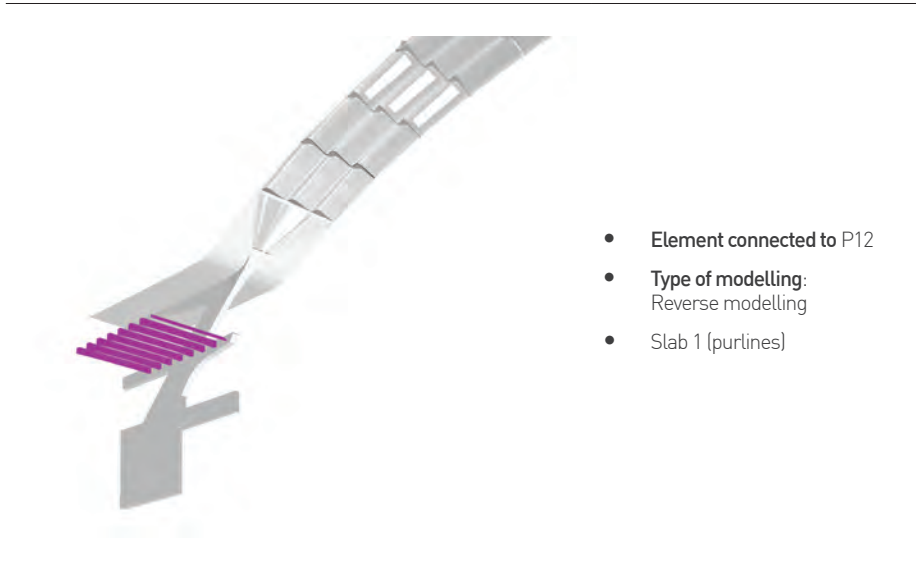
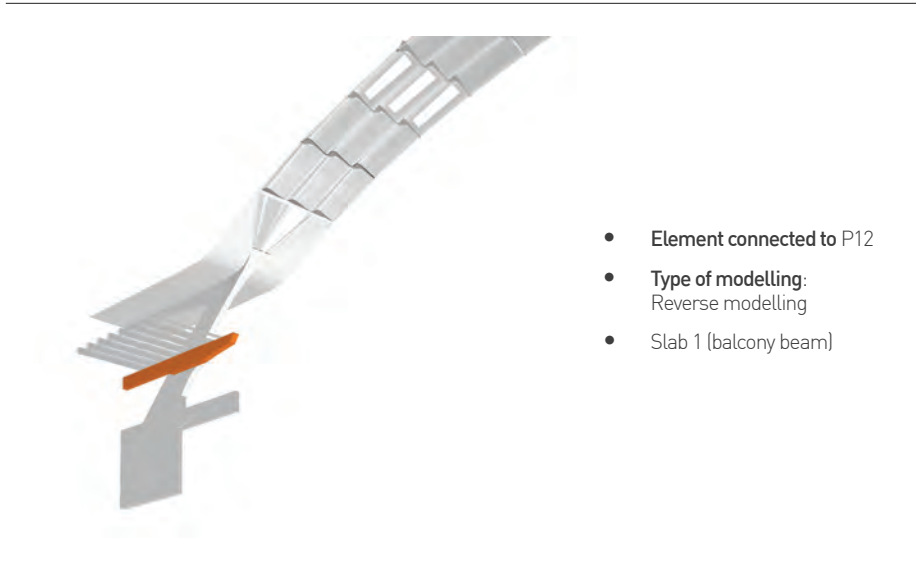

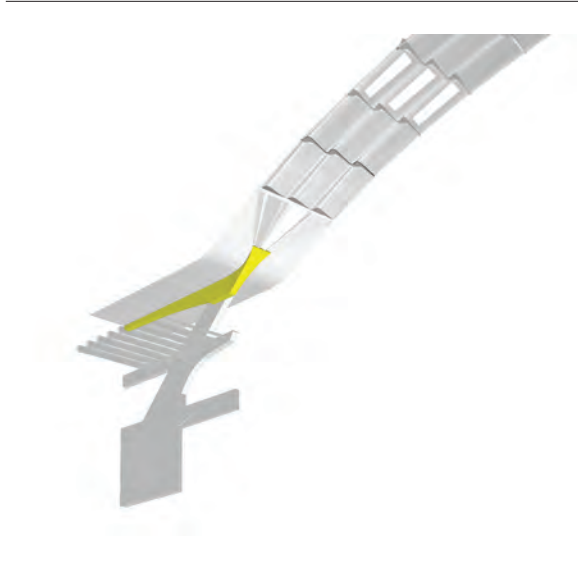

- **Element connected to** P12
- **Type of modelling:**
Reverse modelling
- Beam (Balcony level roof)



- **Element connected to** P12
- **Type of modelling:**
Reverse modelling
- Roof (Balcony level)

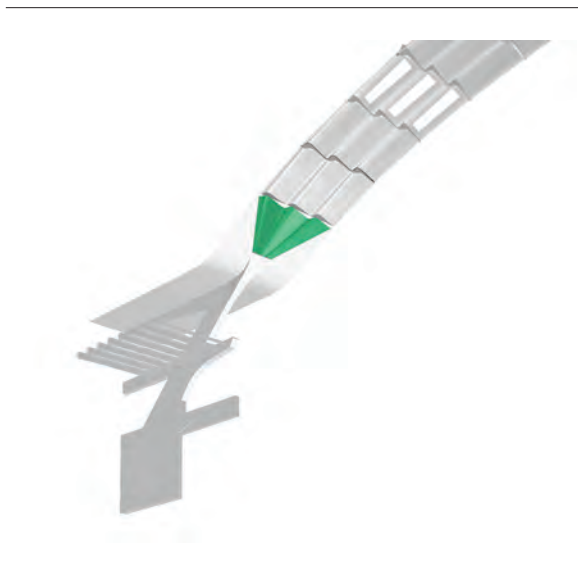

- **Element connected to** P12
- **Type of modelling:**
Reverse modelling
- Vault (fan-shaped element)



- **Element connected to P12**
- **Type of modelling:**
Reverse modelling
- Vault (connections among vault modules)



- **Element connected to P12**
- **Type of modelling:**
Reverse modelling
- Vault modules



- **Hall C large arches**
- **Type of modelling:**
Reverse modelling
- **Structural coding:** 4. Large arches (4.1, 4.2, 4.3, 4.4)
- **3D survey and modelling:**
Terrestrial laser scanning (TLS)
The as-built modelling required that different components are recognisable and segmented from other parts of the buildings.



- Large arches elements segmentation

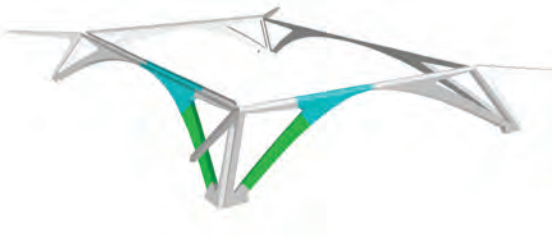

- Large arches elements segmentation



- Large arches elements segmentation
-



- **Large arches elements segmentation**



- **Large arches elements segmentation**

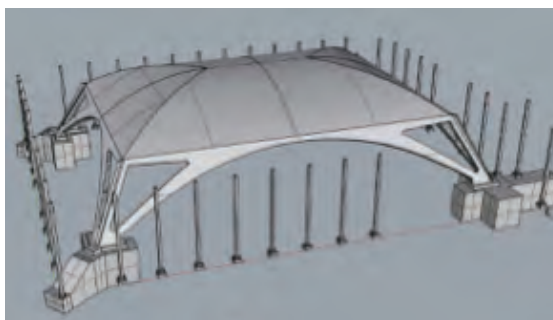

- **Identification:** Foundations and pillars grid of perimetral masonries.
- **Type of modelling:** Recognition of generative geometries from original drawings by Nervi.
- **Structures coding:** 2. Perimetral masonries (2.1, 2.2, 2.3, 2.4), 1 Slab level 0 (1.1. Structure)
- **3D survey and modelling:** the foundations model is derived from Pierluigi Nervi's drawings compared with the thermal survey (Paragraph 3c. 3. The foundations and the grid of pillars of Hall C)

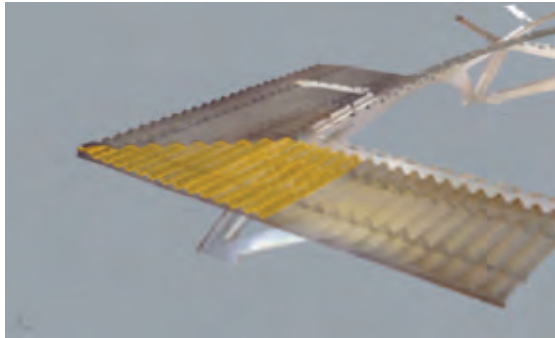

- **Identification:** Slab with wavy elements
- **Type of modelling:** Reverse modelling
- **Structural coding:** 3. Roof. 3.1. Perimeter Slab with wavy elements.
- **3D survey and modelling:** Terrestrial laser scanning (TLS)

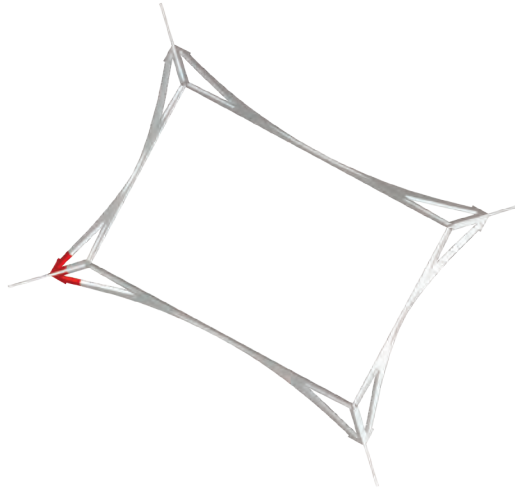

- **Identification:** Hall C - Basement of large arches (by way of example: south-western basement)
- **Type of modelling:** Reverse modelling
- **3D survey and modelling:** Very close-range digital photogrammetry
- **Georeferencing:** scarifications, coring, survey of reinforcement by picometer, punctual positions for internal measurement of temperature and humidity, ultrasonic analysis.



- Scarifications

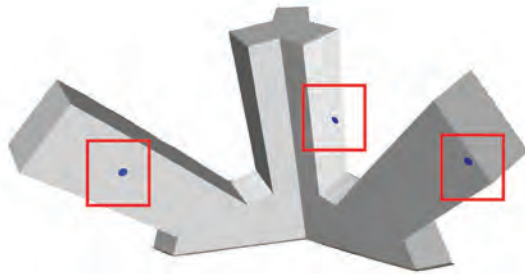

- Corings

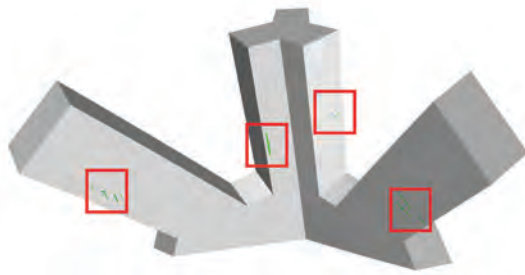

- Survey of the reinforcement by picometer

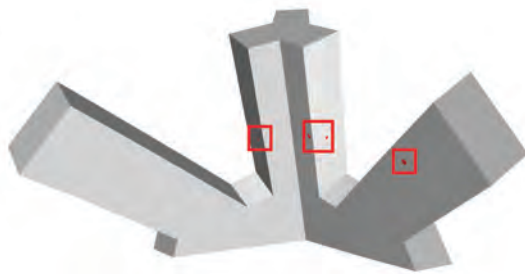

- Punctual positions for internal measurements of temperature and humidity.
-

The entire model (from Figure 8a1.7 to Figure 8a1.11) was generated following the described strategies. It is important to underline how, in each step of the different modelling phases, the operator provided close monitoring as regards metric accuracy and simplification processes, in order to verify the deviation from the original, primary data was acceptable

and consistent with the pre-established aims of the project, the intended outcomes and, therefore, with the scale of the final model. In this case, the discrepancies ranged from a few millimetres to 4-5 centimetres, which was consistent with a representation scale of 1:100/1:200.

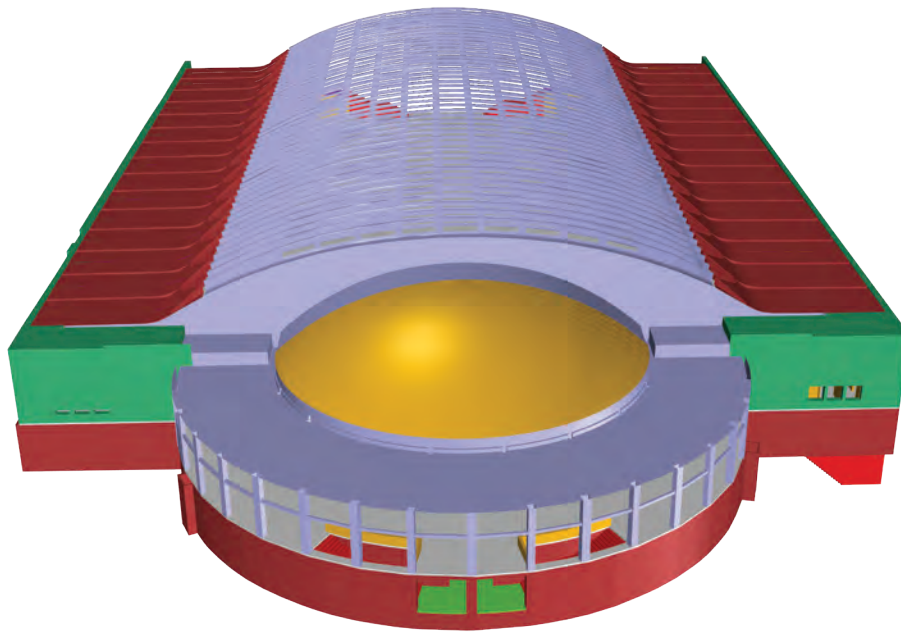

8a1.7: A 3D view of the NURBS model of Hall B, classified according to the different structural and architectural elements.

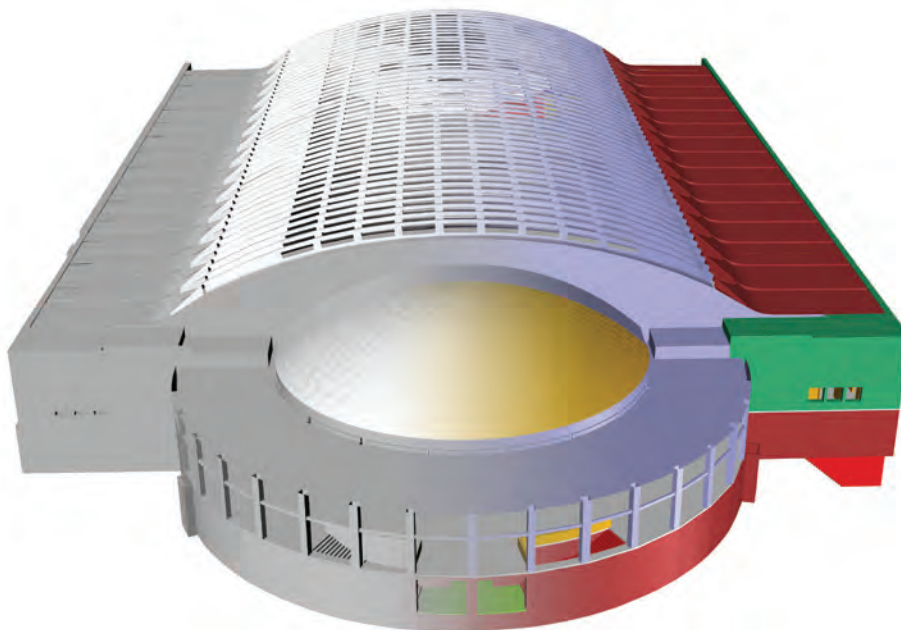

8a1.8: A 3D view of the NURBS model of Hall B. Left: shaded view. Right: classification according to the different structural and architectural elements.

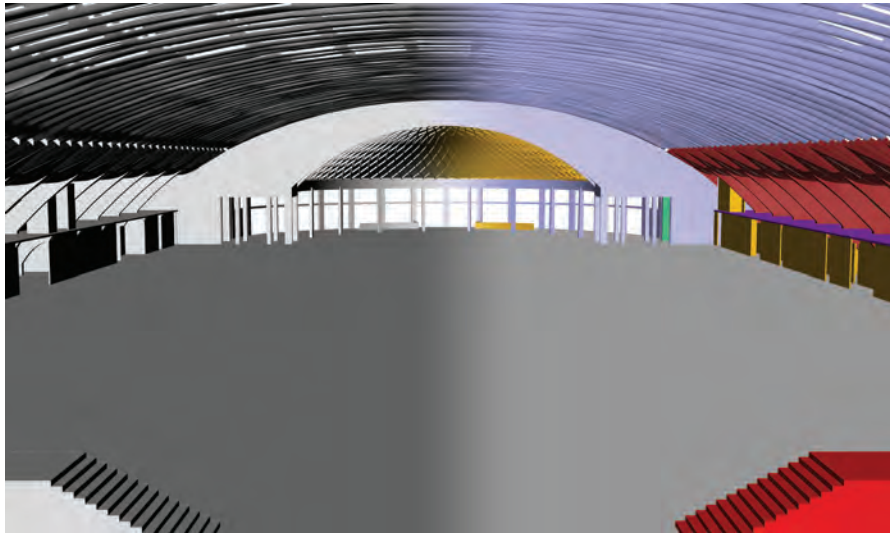

8a1.9: A 3D view of the NURBS model of the indoor areas of Hall B. Left: shaded view. Right: classification according to the different structural and architectural elements.

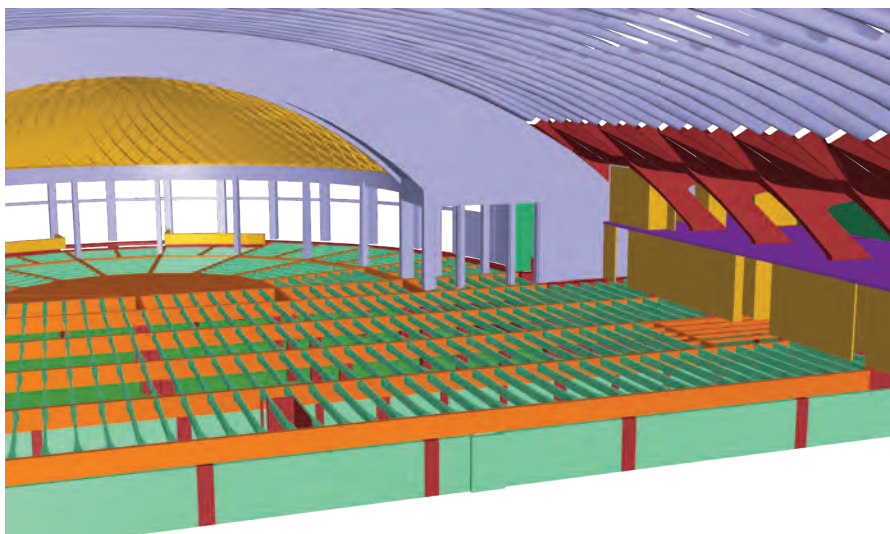
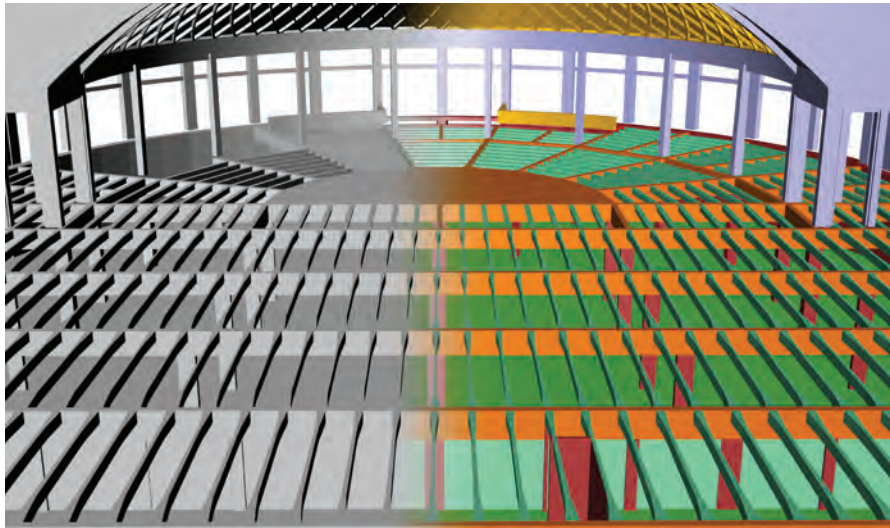

8a 1.10: 3D views of the NURBS model of the indoor areas of Hall B and the structural elements of the ceiling of the underground floor.

8a.2 Data integration and interpretation in a multidisciplinary context: HBIM as multi-contents archive

Starting from the optimised 3D model achieved following the strategies described in the previous section, the main pre-established goal was to create and develop an effective tool to manage the accurate 3D spatial correlation of information, in terms of geometric objects and data from the investigations. Specifically, two key aspects were mainly considered, representing not only crucial phases, but also bottlenecks in the framework of the debate in the research community on spatial and informative data.

- Multi-temporal data management
- Multi-format data interoperability

The need to spatially connect the highly interdisciplinary studies that have always accompanied projects of valorisation

and conservation requires careful consideration. In fact, considering the highly interdisciplinary context in which the current research was carried out, involving the expertise of the different research teams participating in the investigation phases in connection with the knowledge processes, it was necessary to manage and combine the results obtained for an effective documentation. The opportunity to spatially relate the performed diagnostic analyses in a single, digital, 3D archive, in order to provide a spatial and semantic structure for the multidisciplinary and interdisciplinary investigations, can be considered the crucial step of the research.

The need to spatially connect the different results from the investigations conducted with the 3D models of the structures

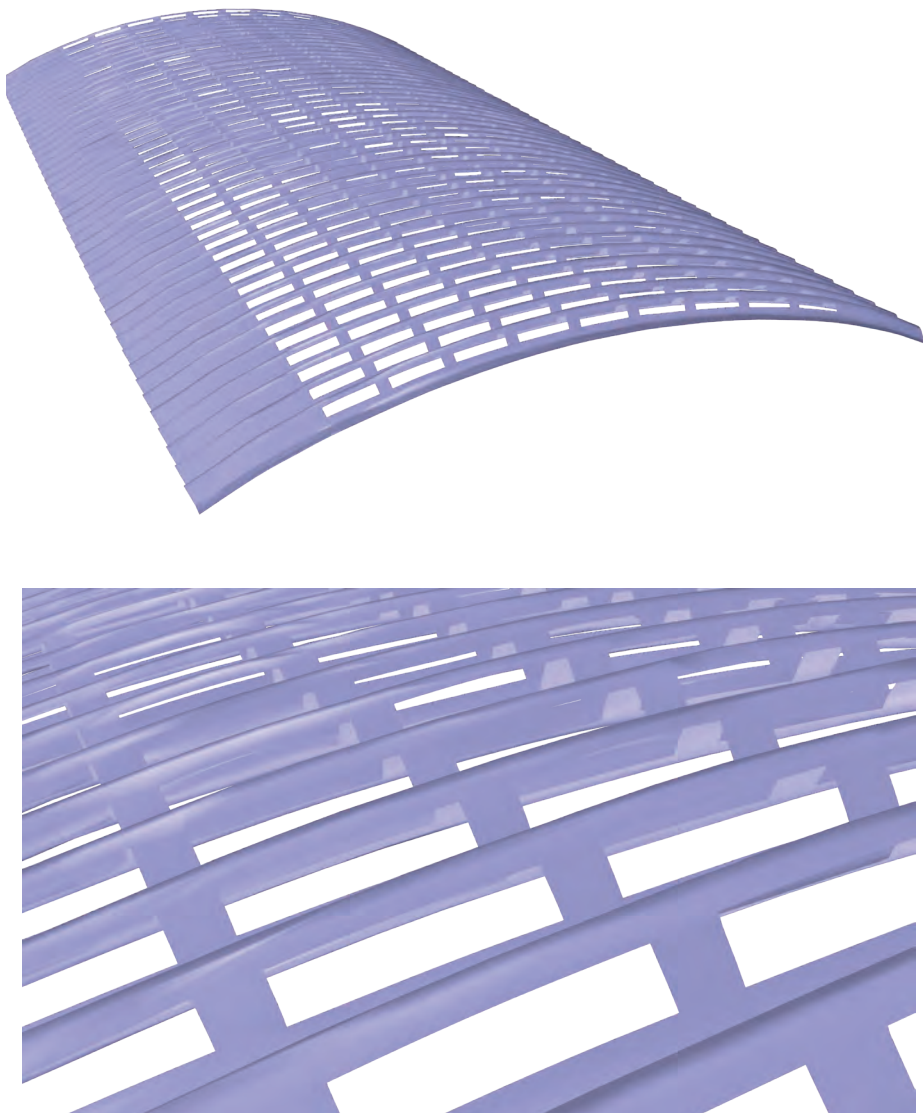

8a1.11 Above: NURBS model of the wavy vault of Hall B. Below: zoom on the details of the NURBS model of the vault.

clearly showed the necessity to develop a strategy to co-record the heterogeneous results of the different investigations with the 3D information, in order to be able to measure and quantify the phenomena emerging from these studies that can only be fully understood by considering the spatial connection with the architectural organism.

As observed in Sections 3.2 and 3.3, the study of Pier Luigi Nervi's original design drawings, together with the interpretation of the building via the aforementioned analyses of the 3D spatial data acquired, enabled a careful evaluation of anomalies and differences to be made between the original project and the as-built building on the construction site. Considering the interesting results obtained and previously described during the in-depth knowledge phase, a similar approach was proposed again at the current stage of digital twin organization, in order to create a three-dimensional connection between the reality-based data acquired during the metric survey campaign and the 3D model created from the original drawings.

A test was carried out on the twelfth pillar in the north row of the P12 module, since it was one of the most investigated structures in that area (georadar investigations; potential analyses; thermal investigations; etc.). In order to manage a similar comparison, we needed to record both models in the same coordinate system; thus, a set of n°9 homologous points had to be identified in order to perform an alignment between the model from the original drawings and the reality-based, 3D point cloud (Figure 8a2.1).

The process described above enabled a comparison (Figure 8a 2.2) that highlighted several significant deviations from the preliminary project and the reality-based model, not only as regards the external surfaces of the pillar, but also concerning the arrangement of the reinforcement irons: these discrepancies were further confirmed by the georadar analyses carried out on the pillar, highlighting some differences between the diagram of the reinforcement irons as originally designed by Nervi and the thin iron structure as actually constructed (Figure 8a 2.3). These results underlined the importance of a robust metric approach (Figure 8a 2.4) to record correctly, in order to establish a robust connection between the information and its spatial context. Furthermore, in addition to a possible correlation between two different 3D models in the same reference system in order to be able to perform analyses and comparisons, it is important to stress, in recent years, the possibility to read non-spatial analyses in a three-dimensional space has been explored. This provided the opportunity to associate a multitude of factors, features and elements that are usually considered separately¹¹. Thus, in order to enhance the interpretation of the results obtained and to enable a 3D visualisation of the analyses (e.g. potential maps, georadar analyses, ecc.) directly on the reality-based model, in some cases a texture, projection-based strategy was followed. Figures 8a 2.5 and 8a 2.6 show two corrosion potential maps projected on to a reality-based, 3D mesh created from LiDAR point clouds.

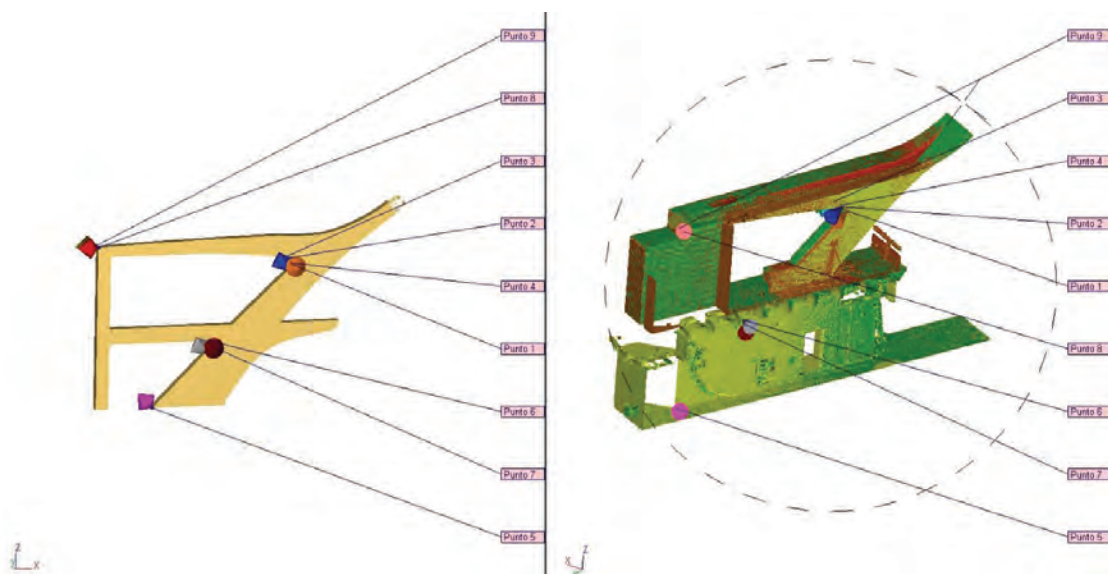

8a 2.1: Point-based registration between the 3D model created from Nervi's drawings and the LiDAR point cloud.

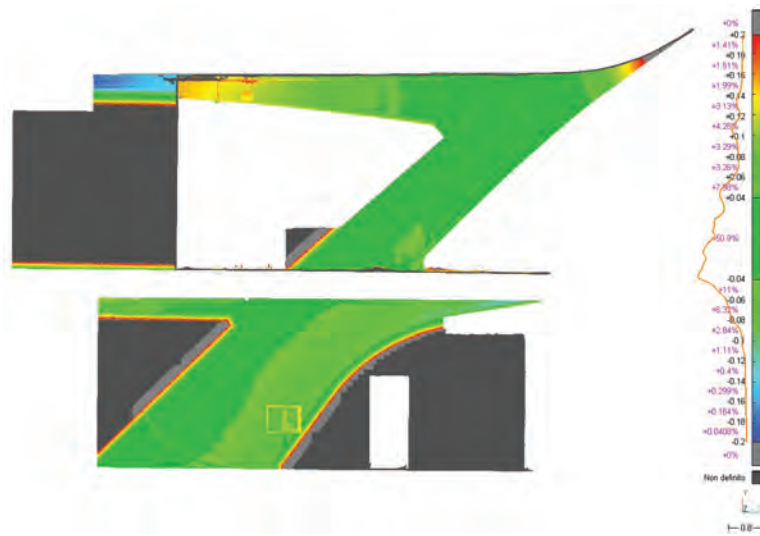

8a 2.2: Discrepancy analyses conducted between the reality-based model (created from LiDAR data) and the 3D model from Pier Luigi Nervi's drawings after the co-registration procedure.

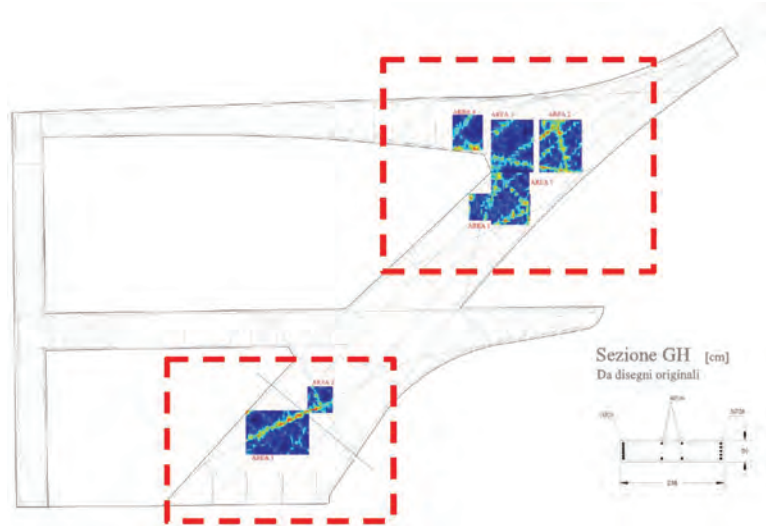

8a 2.3: Overlapping of the reinforcement detected by georadar with respect to the reinforcement as designed by Pier Luigi Nervi.



(a)



(b)

8a 2.4: (a) Integration of the extrados of the P12 pillar module in the reality-based point cloud. (b) 3D models of the internal structural elements developed from the design phase.

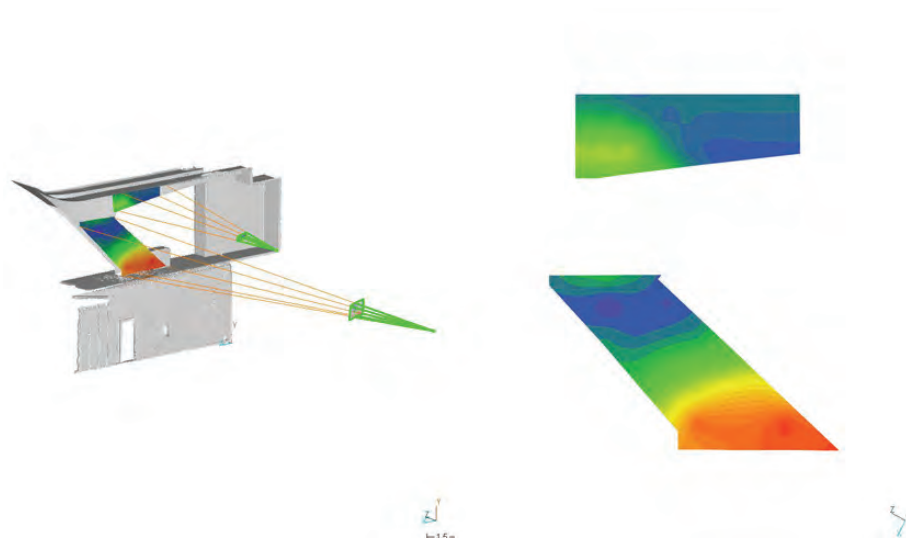

8a 2.5: Projection of the corrosion potential map of the P12 pillar on the reality-based model (3D mesh).

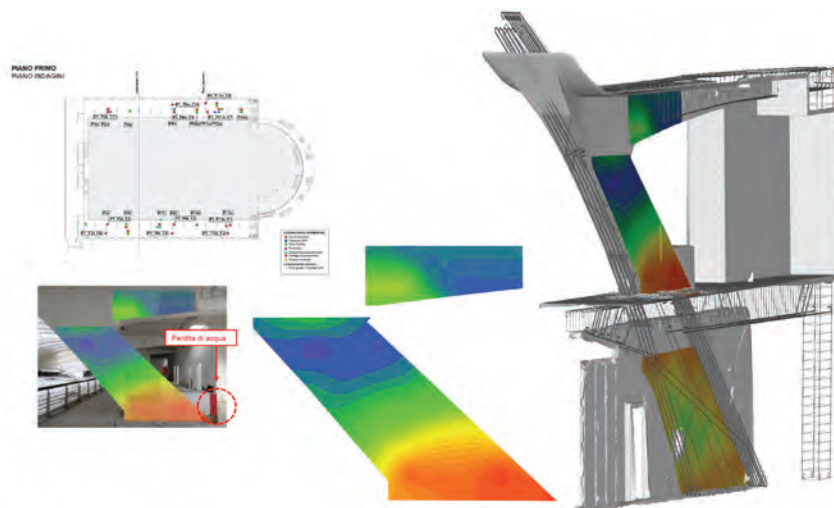

8a 2.6: Corrosion potential map for one of the P12n pillar modules, projected on the reality-based mesh; integration between the textured model and the iron reinforcement (modelled from Nervi's original project drawings).

The examples analysed so far highlighted the need to stratify the information by means of interdisciplinary data integration. They have also shown that, in case of sustainable solutions it is necessary to guarantee sufficient resolution and adequate flexibility, according to the well-known criteria of multi-scale and multi-sensor documentation projects. As regards the multi-temporal point of view, the different phases of the multiple knowledge processes to correctly structure the information from the documentation phases were also addressed.

As already mentioned, constant, accurate monitoring and robust co-recording of data are also mandatory from a hierarchical, multi-scale perspective. In response an extremely high-scale survey should satisfy the documentation of geometric and radiometric consistency before and after diagnostic investigations on the structural and architectural

elements.

As described in Section 3.1, on these specific occasions of interdisciplinary work, an integration of a very-high-scale, close-range photogrammetric survey approach was carried out. It focused on the structural elements covered by the studies and the tests of the multidisciplinary teams and provided an effective, high-resolution documentation of both geometric and radiometric features. In this case, the modelling operations were carried out not only to model the architectural and structural elements of the halls, but also to represent the elements of interest from the structural point of view. A careful classification of the spatial references of the completed analyses in the form of surfaces, linear or punctual entities was carried out. Furthermore, the modelling operations involved not only the structures and geometries of the halls, but also the analyses performed by each research

unit and the investigated surfaces, with the aim of establishing a spatial connection between the examinations carried out¹². The NURBS objects were, therefore, imported into the BIM environment – via a series of complex parametrization processes – to structure the database of data and information connected to the building and to the knowledge analyses, in order to start the data enrichment processes. Therefore, the final, optimised 3D model represented a structured digital archive to host all the elements considered in the previous sections (Figures 8a 2.7 – 8a 2.8)

We can say the parametric paradigm is not only an approach to informative modelling, but it also represents an interesting possibility to connect, manage and query the multi-source information in the related database. The results observed in the previous sections aimed to demonstrate the crucial role of the 3D spatial reference within a system that organizes structured information, which today we call Digital Twin. These enriched models represent an opportunity for experts and researchers and provide additional possibilities for interpreting the results of non-destructive investigations. At the same time, the goal was to investigate not only the open issues related to the parameterization of objects that are complex and irregular

by their very nature, but also other aspects related to the modelling strategies, e.g. resolution, level of simplification, data format, use and integration of standards based on CAD and IFC (Industry Foundation Classes)¹³. In addition to the overall modelling of the spaces and construction systems conceived by Nervi, the study demonstrates how the digitisation of the Turin Exhibition Center required highly detailed insights that enriched the general framework and boosted the most consolidated modelling procedures, bending them to the ferrocement morphologies typical of modern architecture. This was required in response to the need to identify the features and details to be examined in depth using interdisciplinary analysis, in order to contribute to the overall knowledge of the construction. Now, it is more than evident, that the Digital Twins of the architectural organism must be configured not only as a geometric multiscale model based on an as-built strategy that avoids the regularization of the elements, but also as a multi-temporal platform to be updated in the presence of interventions on the construction. A multi-content interpretation is essential for the expert-oriented model, in order to be able to account for the different points of view that have analysed the same objects and phenomena and that have seen and highlighted multiple, multifaceted results¹⁴.

12 Sammartano et al. 2021.

13 IFC (Industry Foundation Classes) standard proposed by the former International Alliance for Interoperability (IAI), now renamed Building Smart. National Institute Of Building Science, United States. National Building Information Modeling Standard. Version 3 – 2015. www.nationalbimstandard.org

14 Patrucco et al. 2022.

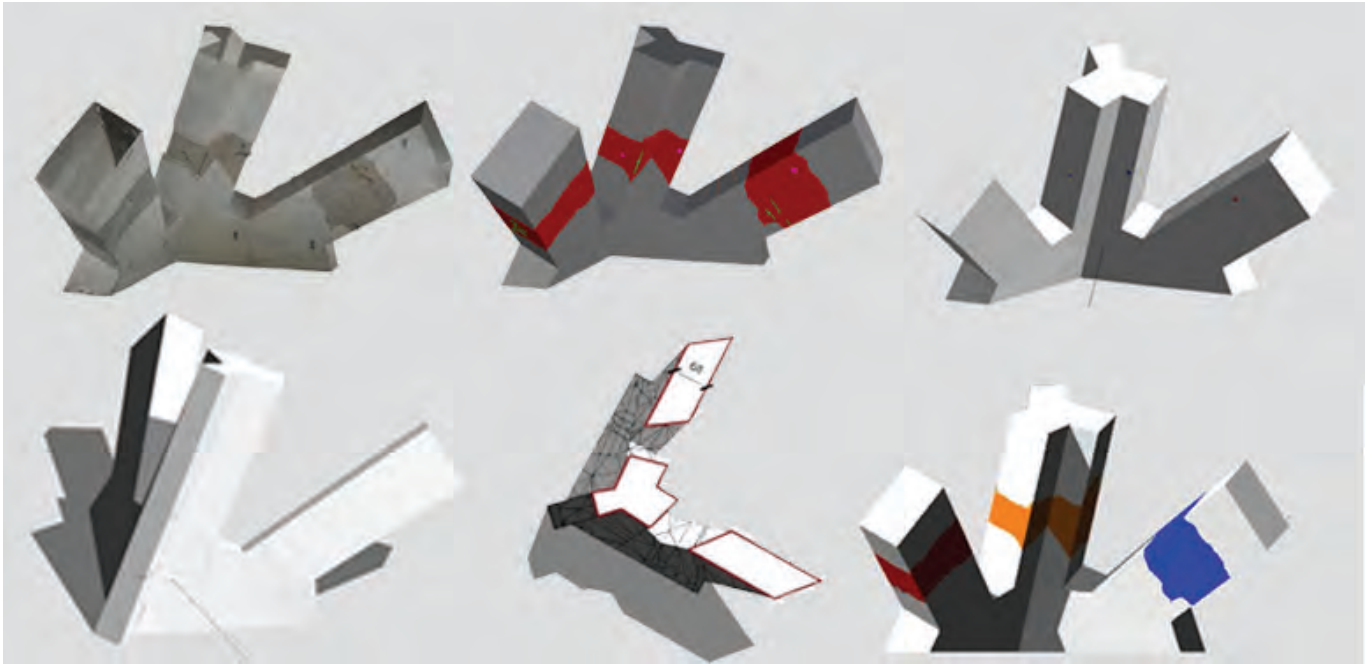

8a 2.7: Above: integration with the structural analyses carried out during the investigation phase. Below: example of the import of the NURBS model into the BIM environment for parametrization purposes.

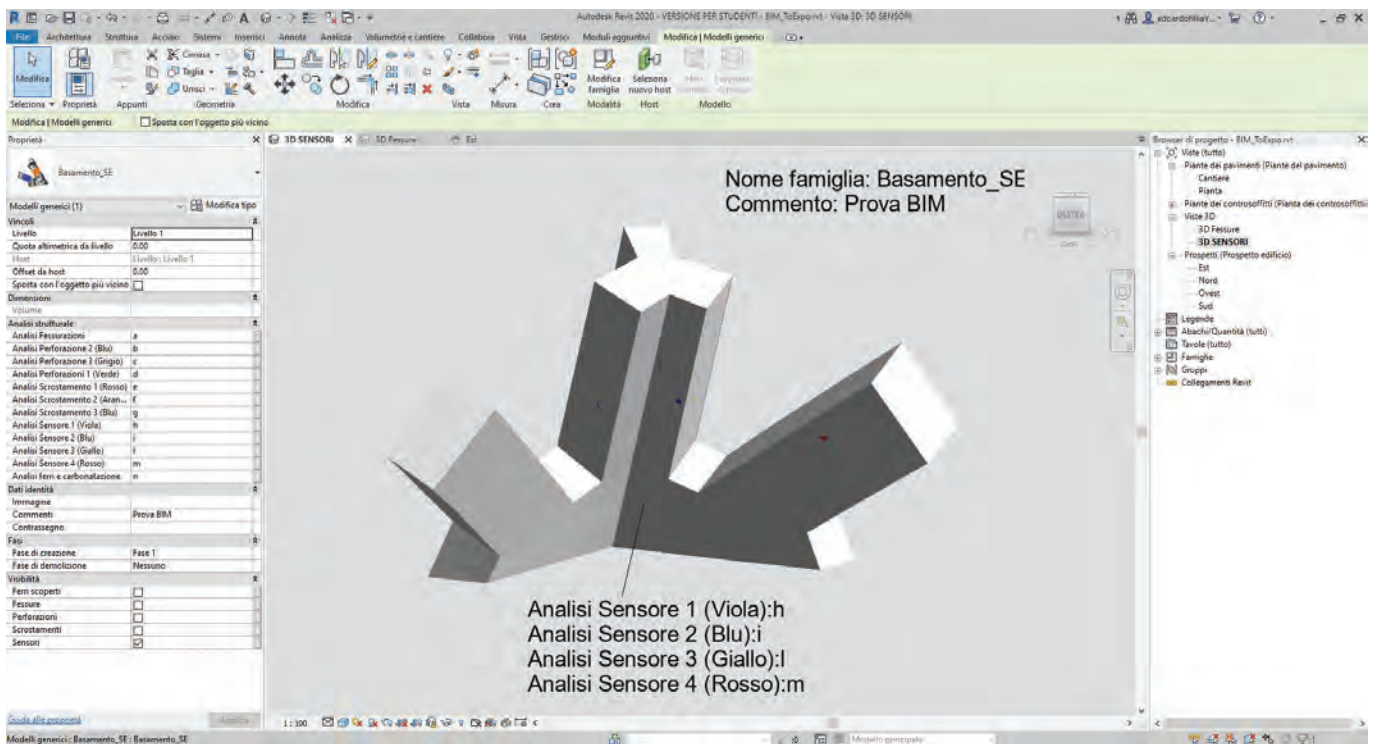

8a 2.8: Integration between the model of the irons (created from Pier Luigi Nervi's drawings) and the reality-based NURBS model (created from the As-Built approach) for parametrization and data enrichment purposes.