

On the interaction between a large landslide and a bridge

*Original*

On the interaction between a large landslide and a bridge / Barla, Marco; Aiassa, Santina; Antolini, Francesco; Vezzaro, Vittorio. - In: *PROCEDIA STRUCTURAL INTEGRITY*. - ISSN 2452-3216. - 62:(2024), pp. 585-592. (Intervento presentato al convegno II Fabre Conference – Existing bridges, viaducts and tunnels: research, innovation and applications (FABRE24) tenutosi a Genova (Ita) nel 12-15 febbraio 2024) [10.1016/j.prostr.2024.09.082].

*Availability:*

This version is available at: 11583/2993241 since: 2024-10-10T06:34:34Z

*Publisher:*

Elsevier

*Published*

DOI:10.1016/j.prostr.2024.09.082

*Terms of use:*

This article is made available under terms and conditions as specified in the corresponding bibliographic description in the repository

*Publisher copyright*

(Article begins on next page)

II Fabre Conference – Existing bridges, viaducts and tunnels: research, innovation and applications (FABRE24)

## On the interaction between a large landslide and a bridge

Marco Barla<sup>a\*</sup>, Santina Aiassa<sup>b</sup>, Francesco Antolini<sup>b</sup>, Vittorio Vezzaro<sup>c</sup>

<sup>a</sup>Politecnico di Torino, Corso Duca degli Abruzzi 24, 10126 Torino, Italy

<sup>b</sup>Geosolving srl, Corso Orbassano 336, 10137 Torino, Italy

<sup>c</sup>Stingeo SA, Via Cavour 30, Andora, Italy

---

### Abstract

The roads and motorways bridge inspection program which is undergoing in Italy is revealing the high number of infrastructures interacting with landslide phenomena. It cannot be otherwise in a country characterized by such a complex morphology. A peculiar example of such soil-structure interaction is that represented by the Rio Bavera bridge in Triora whose abutment is affected by a large landslide. The paper describes this interaction from the phenomenological point of view. The geological and geotechnical investigation carried out to characterize the behavior of the soil and rock formations constituting the large landslide will be illustrated together with the monitoring activities undertaken to understand the mutual interaction between the landslide and the bridge.

© 2024 The Authors. Published by Elsevier B.V.

This is an open access article under the CC BY-NC-ND license (<https://creativecommons.org/licenses/by-nc-nd/4.0>)

Peer-review under responsibility of Scientific Board Members

*Keywords:* Landslides, Bridge, Monitoring, Soil-structure interaction.

---

### 1. Introduction

More than 75% of the territory of Italy is occupied by reliefs, i.e., hills and mountains. This articulated morphology, along with the complex geological, lithological, and structural characteristics induces a very high landslide susceptibility. In the Italian National Landslide Inventory, an area of almost 20,500 km<sup>2</sup> was classified as unstable, equivalent to 6.8% of the Italian territory (Trigila & Iadanza, 2008). The potential interactions between landslides and

---

\* Corresponding author. Tel.: +39-011-0904824

E-mail address: [marco.barla@polito.it](mailto:marco.barla@polito.it)

linear infrastructures such as roads, motorways, tunnels, and bridges are therefore quite common in areas prone to ground instabilities and they are not only limited in time to the construction phase but can affect the infrastructure during its whole service life. Moreover, due to aging the intrinsic vulnerability of every infrastructure experiences a progressive increase in time. In general terms, the higher the linear extension of the infrastructures, the higher the maximum magnitude of the landslide, in terms of the areal extension and the volume of the unstable ground, that can interact with the infrastructure.

In the short to medium term from the onset or the reactivation of slope instability, structural approaches (i.e. the design and the installation of active or passive structural stabilization measures) can sometimes be difficult to be adopted due to the high costs and/or the very large rock/soil volumes involved. In these cases, non-structural measures such as integrated monitoring both of the unstable slope and of the infrastructure coupled with Early Warning Systems (EWSs), capable of mitigating the risk by decreasing the exposure of the elements, are therefore an option at least until the completion of the possible slope stabilization works.

In this paper the example of the Rio Bavera bridge in Triora, whose abutment is affected by a large landslide, will be described. After a brief description of the setting and the instability affecting one of the abutments of the bridge, a description of the geological and geotechnical characterization of the site and the monitoring plan to control the infrastructure are given. Then the monitoring data interpretation and some final considerations about the possible management of the bridge in safe conditions are discussed.

## 2. The Landslide affecting the bridge abutment

### 2.1. The setting

The road viaduct called “Ponte Bavera” which connects the Monesi di Triora village in the municipality of Triora (IM) and the Piaggia village in the municipality of Briga Alta (CN) was built in 1978. The bridge has a curvilinear axis with an overall length of 66 m and three spans of 15, 36, and 15 m and its static layout consists of a simple beam laying on top of two thin wall piers (Fig. 1). The wall piers are connected to the base of the foundation and the bridge deck through hinges. The ground conditions on the two different valley sides were completely different: on the Monesi side, the presence of thick debris cover required the construction of a shaft foundation while on the Piaggia side the pier foundation was directly built on the bedrock. Since its construction, the abutment and the pier foundation shaft on the Monesi side have been affected by anomalous displacements caused by the instability of the slope. Over time the activity of the landslide has determined a progressive tilting of the wall piers and the complete closure of the joint between the bridge deck and the abutment.

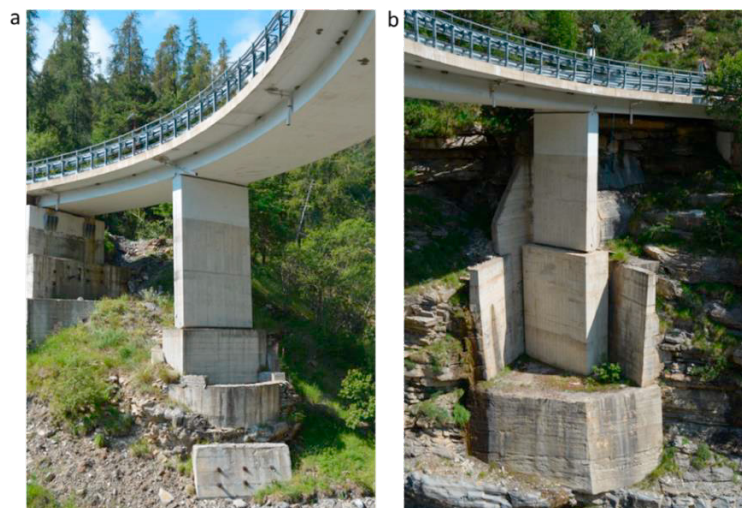

Fig. 1. Views of the Ponte Bavera bridge: (a) abutment and wall pier on Monesi side, (b) abutment and wall pier on Piaggia side.

In 2017 due to the progressive rotation of the piers and the displacement of the deck towards the Piaggia side, the safety conditions of the bridge were judged as insufficient (Blengino, 2017; Collu, 2017) and the infrastructure was closed to traffic. Subsequently from 2018 to 2019, the bridge was subjected to partial retrofitting works consisting of the renewal of the expansion joints with the complete release of the bridge deck from the bearings and the reinforcement of the abutment on the Piaggia side.

2.2. Geological and geotechnical characterization

Over the years, the area has been subjected to various investigation campaigns aimed both at the general study of the numerous landslides in the Monesi di Triora area and the more detailed studies of the area close to the Ponte Bavera bridge. In 1995, the first geological and geotechnical survey campaign was carried out (Mascia, 1998) with the execution of the S5 continuous core drilling borehole located on the circular foundation shaft on the Monesi side.

From 2017 to 2019, following a large flooding event that caused the activation/reactivation of numerous landslides and the occurrence of a large debris flow along the Rio Bavera with significant damages to buildings and infrastructures (Zerbato, 2017), the Municipality of Triora has carried out an extended survey campaign of the whole slope close to Monesi di Triora village. In particular, near the Ponte Bavera, which was closed to traffic after the flood event, four boreholes equipped with inclinometer casing (SMT06, SMT08, SMT11, and SMT12), three open standpipe piezometers (SMT07, SMT09, and SMT10), two seismic and geoelectrical tomographic profiles and a detailed topographic survey of the slope, the river bed and the bridge were completed. The location of the described surveys is shown in Fig. 2. During the borehole execution, in situ and laboratory tests were carried out on samples recovered from drilling to determine the geotechnical characteristics of the rocks and soils involved in the instability.

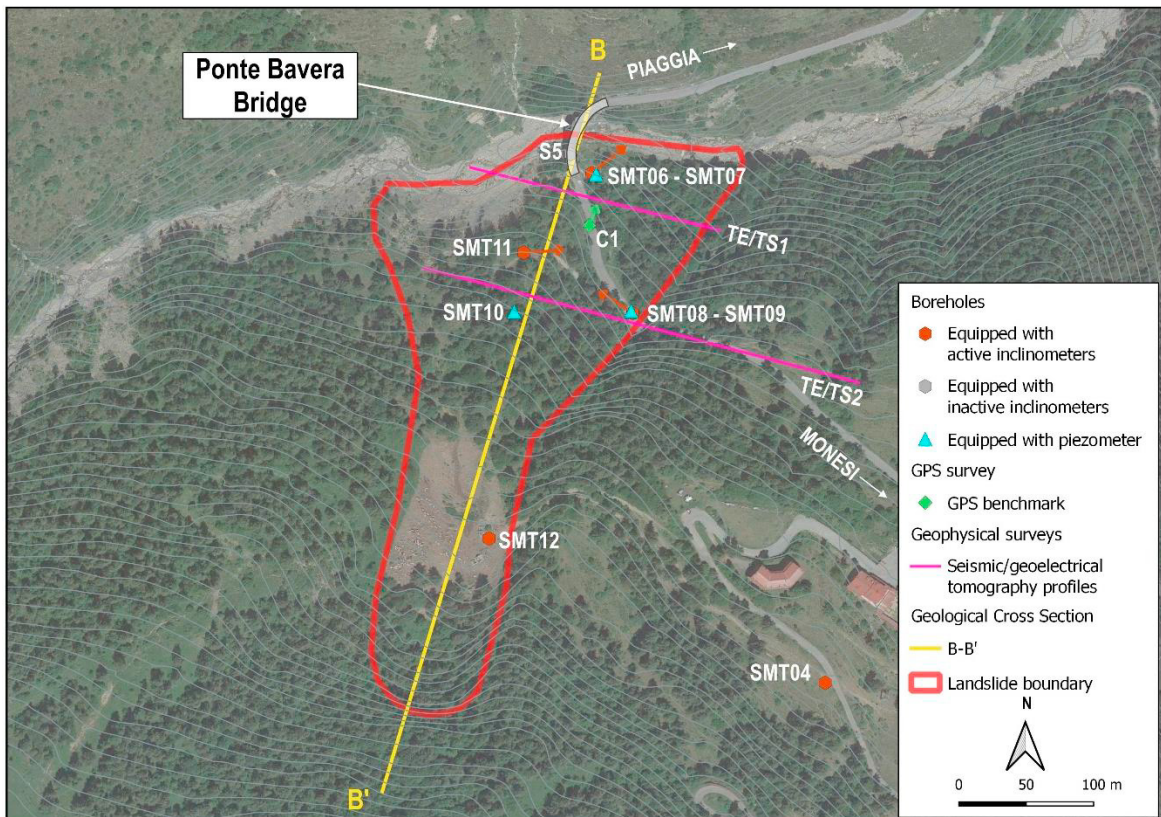

Fig. 2. Plan view of the Ponte Bavera bridge area showing the location of the boreholes, the geophysical survey profiles, the GPS benchmarks, and the boundary of the landslide affecting the right abutment of the bridge (Monesi side).



The interpretation of the data retrieved from all the surveys carried out allowed to identify the possible boundary of the landslide affecting the right abutment of the bridge which extends upslope for 500 m from the river bed of the Rio Bavera to the main scarp located at about 1450 m a.s.l. This landslide is superimposed over a very large Deep-Seated Gravitation Slope Deformation (DSGSD) which affects the whole NE side of the Saccarello Mount (Zerbato, 2017).

Fig. 3 illustrates the geological longitudinal section of the unstable slope. The landslide affects the whole superficial debris cover, up to 40 m thick and made of boulders, blocks, cobbles, and gravels in a sandy-silty matrix, that lies above the bedrock (Helminthoid Flysch). The sliding surface, identified by the inclinometric profiles, is located at the contact between the bedrock and the debris cover or within the most superficial and weathered bedrock layers. Moreover, by analyzing the SMT06 inclinometric profile it is worth noting that the sliding surface is located at the base of the foundation shaft of the wall pier on the Monesi side. The piezometric levels in the standpipe piezometers indicated that the groundwater table is mainly located close to the contact between the debris and the bedrock and has a marked gradient towards the river bed. The movement along the sliding surface could be further promoted by the orientation of the Flysch layers dipping out of the slope and by the infiltration of water along it, particularly during rainfalls and the snow-melting period.

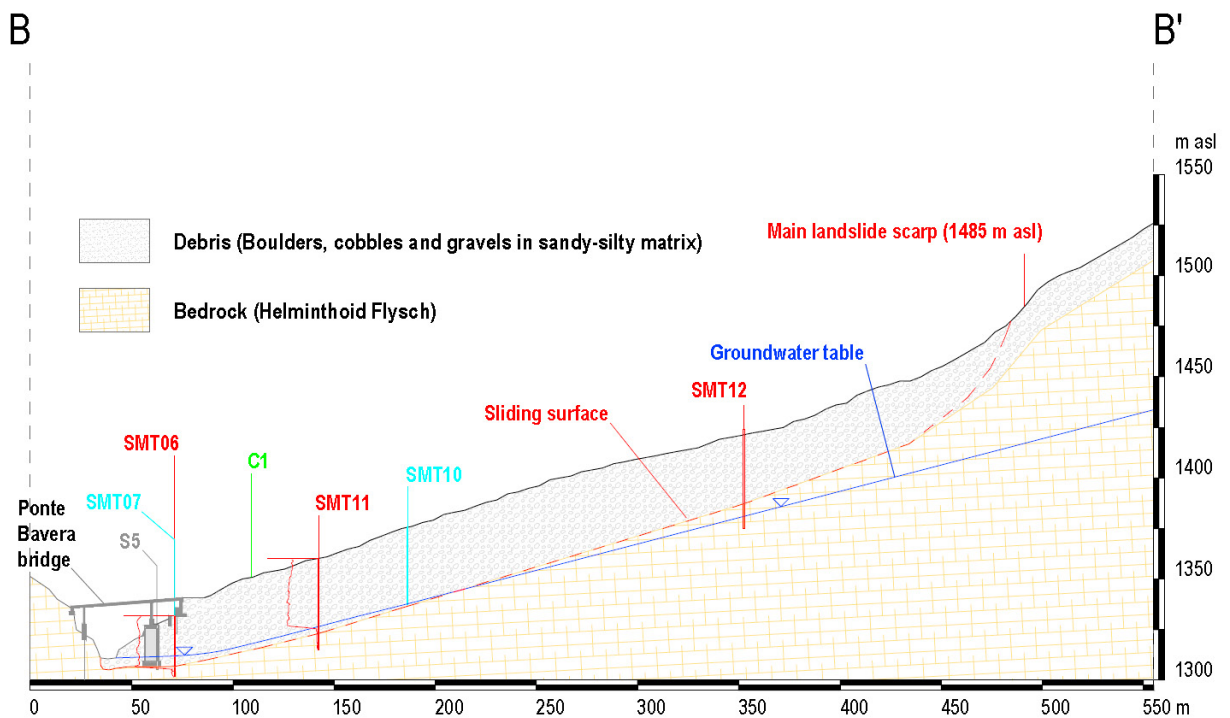

Fig. 3. Geological cross-section along the right shoulder (Monesi side) of the Ponte Bavera bridge with indication of the inclinometric profiles and the position of the groundwater table.

### 2.3. The monitoring system

After the closure of the bridge in 2017, a specific monitoring system was installed to verify the performance and the behavior of the structure. The system consists of 11 electrical joint meters (F1-F11) located on the abutments and wall piers of the bridge and 2 temperature sensors connected to a control unit for the collection and data transmission (Fig. 4). Further manual measurements of the displacement of the expansion joint on the Monesi side are also periodically carried out.

In addition to the bridge, the slope is also monitored through:

- 3 water level sensors placed inside SMT07, SMT09, and SMT10 piezometers; the sensor in SMT07 was connected to an automatic data acquisition and transmission control unit while the sensors in SMT09 and SMT10 were connected only to data loggers whose data are downloaded manually;
- Manual inclinometric measurements on SMT08 and SMT11;
- Automatic inclinometric measurements with three fixed probes on SMT06 connected to an automatic data acquisition and transmission control unit (manual measurements were also carried out after extracting the probes from the borehole);
- A GPS survey benchmark (C1) managed by ARPA Piemonte.

The location of all the instruments installed along the slope is shown in Fig. 2.

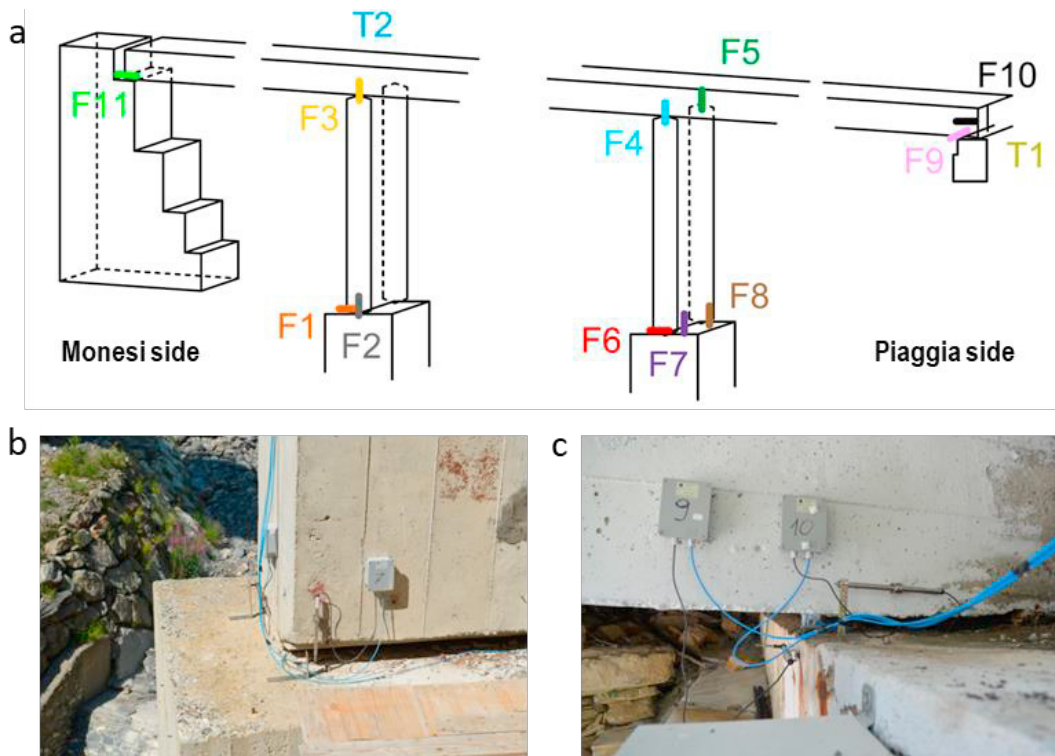

Fig. 4. (a) Schematic view of the location of the crack meters and temperature sensors on the bridge; (b) Detail of the F6 and F7 joint meters installed at the base of the wall pier on Piaggia side; (c) Detail of the F9 and F10 joint meters installed between the bridge deck and the abutment on Piaggia side.

#### 2.4. Data interpretation

To understand the possible interaction between the slope movements and the response of the bridge it is necessary to compare the data acquired along the slope with those measured on the structure and the main meteorological parameters such as rainfalls and snowfalls.

The time series of the monitoring data measured by the sensors installed both on the bridge and along the slope starting from 2017 are shown in Fig. 5 which illustrates in detail the temporal trend of the monitoring data starting from October 2019 to January 2021. The rainfall and snow data recorded by the Arpa Piemonte Piaggia - Pian del Guso weather station, located approximately 1.5 km SW of the bridge and at an altitude of 1645 m above sea level, are also reported.

It is of particular interest to analyze the trend of the data following the completion of the retrofitting works that occurred in September 2019. After an initial phase of readjustment of the structure according to the new static scheme,

the joint meters F1 and F2, located at the base of the pier on the Monesi side, showed a substantial slowdown of the movements. The joint meter F1, which previously showed a closing trend, was now essentially stationary while F2, which showed an opening trend, mostly seems to oscillate together with seasonal temperature variations. The F6 and F7 joint meters, located at the base of the pier on the Piaggia side, respectively show a general trend in opening and closing and also seem to be influenced by seasonal temperature variations.

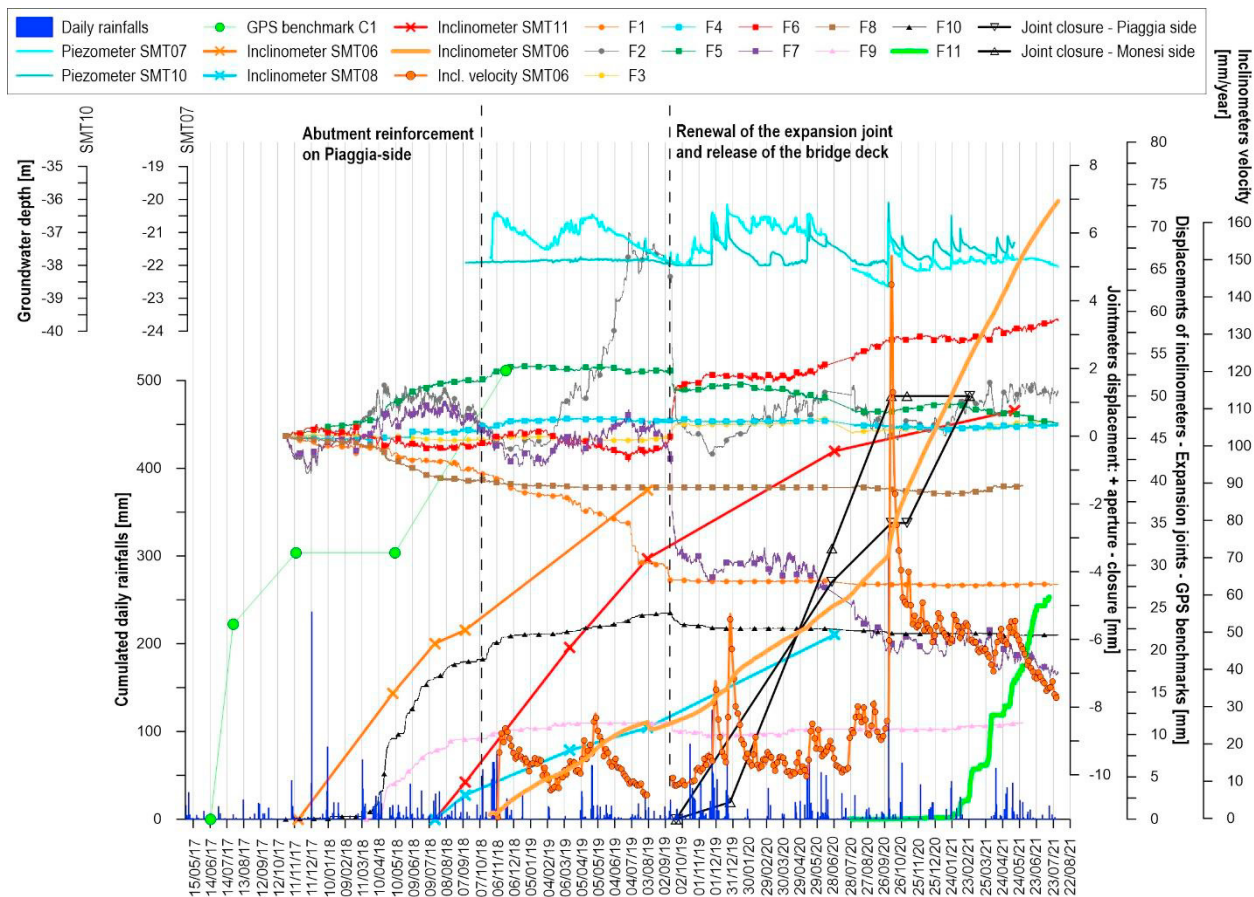

Fig. 5. Measurements of the joint meters and the temperature sensors installed on the bridge, of the automatic inclinometer SMT06 and the piezometric level SMT07 along the slope compared to daily rainfalls and the height of the snow cover from 2017 to 2021.

The result of the manual measurements of the expansion joint on the Monesi side highlighted a marked movement of the shoulder towards the valley, with joint closure equal to 50 mm between September 2019 and February 2021 (average velocity of 2.9 mm/month). These data can be compared with those of the topographic survey campaign carried out in the past by the Technical Division of the Province of Imperia, which recorded a horizontal displacement of 190 mm of the abutment and 208 mm at the head of the wall pier on Monesi side between March 1995 and September 1998 (Mascia, 1998) (average velocity of 4.8 mm/month). The F11 crack meter, active since July 2020 and located right across the joint, began to record a closing trend starting in January 2021.

The most relevant monitoring data along the slope is the SMT06 automatic inclinometer, which detects an almost continuous movement of the landslide, in accordance with the manual measurements taken along the same vertical. The graph in Fig. 5 shows the time series of the displacement resultant at a depth from 24 to 27 m from the ground surface where the 3 fixed inclinometric probes were positioned.

Between 2 and 3 October 2020, Piedmont was affected by exceptionally intense rainfall which affected in particular the areas of the upper Tanaro valley and the areas close to the border with Liguria and France. On October 3, the

Piaggia – Pian del Guso weather station recorded an exceptional cumulative precipitation value of 327 mm. Following this event, a marked increase in the displacement velocity of the three fixed inclinometric probes within the SMT06 vertical from approximately 20 mm/year to over 50 mm/year was measured. Approximately 7 months after the event (May 2021), a displacement velocity value of approximately 50 mm/year was still recorded.

The correlation between rainfalls, the increase of groundwater levels in the SMT07 and SMT10 piezometers, and the acceleration of the inclinometers are also evident not only for the October 2020 event but also for previous rainfall events (in particular in November 2019, December 2019, and May 2020). Nevertheless, the velocity was characterized by a quick return to pre-event values (around 20 mm/year) for these less intense events.

### 3. Discussion and final considerations

The bridge displacements and rotations are caused by an active landslide which interacts in a complex way with the structure. The landslide, as it was possible to reconstruct, involves the whole debris cover for a thickness of up to 40 m and it has an approximate extension of 500 m x 260 m at the toe and an estimated volume of approximately 1.2 Mm<sup>3</sup>. Near the bridge, the sliding surface is located at the base of the foundation shaft of the wall pier on the Monesi side. Moreover, the slope instability is located inside the Deep-Seated Gravitational Slope Deformation which affects the whole NE side of the Saccarello Mount (Zerbato, 2017). The slope movement seems to be favoured by the intrinsic mechanical contrast between the debris and the underlying bedrock, by the rock bedding planes dipping towards the riverbed, and by the water infiltration and flow along the debris/bedrock contact. The monitoring measurements carried out show that the landslide moves at an almost constant velocity and accelerates during intense rainfalls and the snow melting period.

The bridge retrofitting works completed in September 2019 through the reopening of the expansion joint allowed to temporarily lower the pressure thrust exerted on the bridge by the landslide on the Monesi side. However, the slope inclinometric measures continue to show a progressive sliding of the landslide body towards the Rio Bavera riverbed which, and, from the flood event of 3 October 2020, has also undergone a marked acceleration which is still ongoing today. The effect of the landslide on the bridge causes a progressive closure of the expansion joints and the progressive translation of the foundation shaft of the wall-pier on the Monesi side. In turn, the pier connected to the foundation shaft and the deck through hinges reacts to the downstream movement of the base of the well by behaving like a connecting rod and progressively tilting towards the upstream. As long as the joints remain open, the bridge deck undergoes very limited displacements. Fig. 6 shows a two-dimensional simplified schematization of the kinematics of the interaction between the slope and the bridge. The scheme shown is purely indicative as the curvature of the deck and the geometry of the phenomenon also involve out-of-plane displacements and rotations, as documented by the monitoring data.

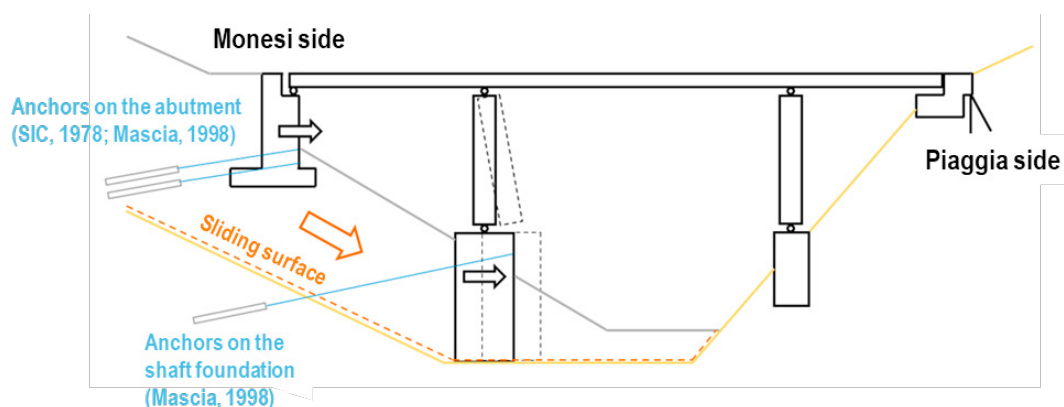

Fig. 6. Diagram of the possible kinematic interaction between the slope instability and the Ponte Bavera bridge.



The approach adopted based on the in-depth analysis of the geological and geotechnical context as well as the monitoring data allowed therefore for the realistic reconstruction of the kinematic of the mutual interaction between the landslide and the Ponte Bavera bridge.

## Acknowledgements

The authors would like to acknowledge the Municipality of Triora and Dott. Filippo Vigna for the help provided for data processing and interpretation.

## References

- Blegino, C., 2017. Ponte sul rio Bavera – Relazione tecnica. Provincia d’Imperia (In Italian).
- Collu, A., 2017. Ponte sul rio Bavera – Note sulla stabilità del ponte. Amministrazione provinciale di Imperia (In Italian).
- Mascia, D., Mascia, L., 1998. Opere di consolidamento del ponte sul Rio Bavera nel Comune di Triora. Amministrazione Provinciale di Imperia (In Italian).
- Romano, L., 2018. Messa in sicurezza ponte sul rio Bavera in località Monesi - Progetto definitivo - esecutivo. Comune di Triora – Provincia di Imperia (In Italian).
- SIC – Studio di Ingegneria Civile s.a.s. Ingg. Corona G. e Perazzone R., 1975. Progetto del ponte sul rio Bavera per il collegamento con la provincia di Cuneo – Opere di difesa e presidio della spalla lato Monesi. Amministrazione provinciale di Imperia (In Italian).
- Trigila, A., Iadanza C., 2008. Landslides in Italy – Special Report 83/2008, 30 pp. APAT, Roma. ISBN 978-88-448-0355-1.
- Zerbato, M., 2017. La frana di Monesi (IM) - L’evento alluvionale del 21-25 novembre 2016: caratteristiche, casi studio, aspetti normativi e progettuali sugli interventi derivati. Regione Piemonte, Arpa Piemonte, CNR – IRPI (In Italian).