

Monitoring and managing of a micro-smart grid for renewable sources exploitation in an agro-industrial site

Original

Monitoring and managing of a micro-smart grid for renewable sources exploitation in an agro-industrial site / Fabrizio, E., Branciforti, V., Costantino, A., Filippi, M., Barbero, S., Tecco, G., Mollo, P., Molino, A.. - In: SUSTAINABLE CITIES AND SOCIETY. - ISSN 2210-6707. - STAMPA. - 28:(2017), pp. 88-100. [10.1016/j.scs.2016.08.026]

Availability:

This version is available at: 11583/2663483 since: 2024-02-02T20:35:10Z

Publisher:

Elsevier

Published

DOI:10.1016/j.scs.2016.08.026

Terms of use:

This article is made available under terms and conditions as specified in the corresponding bibliographic description in the repository

Publisher copyright

Elsevier postprint/Author's Accepted Manuscript

© 2017. This manuscript version is made available under the CC-BY-NC-ND 4.0 license
<http://creativecommons.org/licenses/by-nc-nd/4.0/>. The final authenticated version is available online at:
<http://dx.doi.org/10.1016/j.scs.2016.08.026>

(Article begins on next page)

Progressive Damage Analysis of Green Composite Laminates subjected to In-Plane Crashworthiness

Part C: Journal of Mechanical Engineering Science
XX(X):1-7
©The Author(s) 2024
Reprints and permission:
sagepub.co.uk/journalsPermissions.nav
DOI: 10.1177/ToBeAssigned
www.sagepub.com/

SAGE

Valentina Giammaria¹, Giulia Del Bianco¹, Dario Fiumarella², Raffaele Ciardiello², Lorenzo Vigna³, Simonetta Boria¹, Alessandro Scattina², Giovanni Belingardi², Vincenzo Castorani⁴

Abstract

In this paper the initiation and propagation of delamination in thin-walled green composite structures were studied. In particular, laminates of flax and hemp fibers with epoxy resin were investigated from experimental and numerical points of view, using the finite element code LS-DYNA. First, an experimental campaign was conducted using DCB and 4ENF tests to obtain the values of the interlaminar fracture modes, required for the cohesive fracture modelling. In addition, in-plane crashworthiness tests were performed on composite plates to analyze the damage of the specimens, under both quasi-static and dynamic conditions. A trigger mechanism was considered to help delamination to start and to ensure the most progressive crushing possible. The predominant damage mode was splaying, but some ply fragmentation in the middle layers and some buckling phenomena were also observed. In general, more stable progressive crushing was observed under dynamic conditions than under quasi-static ones, even if a reduction in terms of absorbed energy was obtained by moving to the dynamic condition. The numerical predictions showed a good agreement with the experimental reference results, validating the current framework for crashworthiness analysis of green composite structures.

Keywords

Green composites, Natural fibers, Delamination, Crashworthiness, Finite element numerical modelling.

Protecting the atmosphere and biodiversity and mitigating the effects of climate change are some of the most important goals of our time. For this reason, the growing awareness over the years related to environmental impacts has led the European Union to adopt a series of regulations in different areas¹, such as limiting the production of single-use plastic objects and packaging. Another area of application of the directives concerns pollution from vehicles². In 2012, the European Union decided to reduce average emissions from motor vehicles by 27% from 2015 to 2021 and by another 15% and 37.5% from 2025 and 2030, respectively. All these regulations have led to an increased use of composite materials in the automotive sector, as they offer potential advantages such as improved impact resistance, recyclability, and also lower weight³, properties that are particularly useful for all vehicles. For this reason, nowadays, improving sustainability and quality of eco-friendly products are the main challenges for researchers and industries by evaluating new green composite solutions. The use of natural fibers would indeed help to reduce pollution issues, such as waste, landfills, toxins, and greenhouse gas emissions. Natural fibers have low density and a high strength-to-weight ratio, making them a potentially lightweight reinforcement in composites. Recently, several car manufacturers have used natural fiber composites (NFCs) for some interior parts, like door-trim panels, seat backs, and parcel shelves^{4,5}. In this sector, the most used natural fibers are flax and hemp; therefore this work aims to compare their properties, with the final aim to decide which could be the best one for the design of a structural component. To do this, a complete

experimental campaign including tensile, four-point bending and low-velocity impact tests has already been carried out⁶. However, the mechanical characterization obtained performing the basic tests, is not sufficient to have a complete overview on the material behaviour. For this reason, here, the phenomenon of delamination in flax and hemp/epoxy composites is investigated from both experimental and numerical perspectives, considering DCB, 4ENF, and in-plane crashworthiness tests.

After an initial description of the materials involved in this study, the three tests mentioned above were experimentally described. Then, the corresponding Finite Element (FE) models were created and solved using LS-DYNA⁷. The main objective of this work was to provide a first good reproduction of the load-displacement experimental trend. There are several experimental studies on the behavior of composite materials in a crash event, but the lack of a

¹ School of Science and Technology, Mathematics Division, University of Camerino, Via Madonna delle Carceri 9, 62032 Camerino, Italy

² Department of Mechanical and Aerospace Engineering, Politecnico di Torino, Corso Duca degli Abruzzi 24, 10129 Torino, Italy

³ ITW Test and Measurement Italia S.r.l., Instron CEAST Division, Pianezza, Italy

⁴ HP Composites SpA, Dipartimento di Ricerca e Sviluppo, Via del Lampo S.N., Z.Ind.le Campolungo, 63100 Ascoli Piceno, Italy

Corresponding author:

Valentina Giammaria (V. Giammaria)

Email: valentina.giammaria@unicam.it

standardized procedure makes this investigation difficult⁸. In particular, different geometries have been analysed, such as tubes with different cross-sections⁹⁻¹², C-shape and S-shaped specimens¹³⁻¹⁵. All these geometries were self-supporting, but sometimes they were difficult to manufacture. For this reason, this work focused on flat geometry, which seems to be easier to manufacture. Despite this apparent advantage, a specific antibuckling fixture is required, which could influence the mechanical behavior¹⁶. This suggests that additional work needs to be done, but this study represents a first phase in which some experimental behaviours were compared with numerical ones. Considering the good results obtained, it can be stated that, once well calibrated, these models will be able to predict the mechanical response of complex components in the design phase¹⁷, showing the potential of NFCs.

In the future, these fibers could be used as partial or full replacements for synthetic fibers in structural components to meet technical regulations, where applicable, and to provide high mechanical strength, light weight, and recyclability. In this context, the authors are interested in modelling structures for energy absorption with NFCs; therefore, all the results shown in this paper are part of a preliminary study in view of these future applications.

1 Experimental tests

1.1 Materials

Experimental tests were performed on flax and hemp/epoxy composite laminates provided by HP Composites SpA. They were manufactured using PrePregs composed of an epoxy resin and two woven fabric reinforcements characterized by different fiber architectures, namely flax (balanced Twill 2×2, 350 gsm, RC=38%) and hemp (unbalanced Turkish satin, 430 gsm, RC=35%). Both configurations were cured in autoclave at 135 °C and 6 bar for 90 minutes, with an initial heating ramp and a final cooling ramp to ensure uniform temperature distribution and avoid deformation of the samples. All the specimens involved in this study consist of 8 layers, for a total thickness of 3.6 mm.

The mechanical properties of these laminates obtained from the previous characterization tests are listed in Tables 1 and 2. DCB, 4ENF, and in-plane crashworthiness tests are described in detail below.

1.2 DCB and 4ENF

Double Cantilever Beam (DCB) tests were performed to evaluate the Mode I interlaminar fracture toughness G_{Ic} , according to ASTM D5528-94a. The specimens have a

Table 1. Experimental tensile properties of flax and hemp specimens. E: Young modulus; σ_u : ultimate strength; G: shear modulus⁶.

	Orientation	E [MPa]	σ_u [MPa]	G [MPa]
Flax	0°	16079	152	
	45°	7330	84	2227
	90°	19518	170	
Hemp	0°	13429	117	
	45°	7041	75	2188
	90°	21064	231	

Table 2. Experimental flexural properties of flax and hemp specimens. E_B : Flexural modulus; $\sigma_{u,B}$: ultimate flexural strength⁶.

	Orientation	E_B [MPa]	$\sigma_{u,B}$ [MPa]
Flax	0°	12446	163
	45°	6905	144
	90°	13251	168
Hemp	0°	10948	150
	45°	6318	132
	90°	16363	198

rectangular shape (180 mm x 20 mm) with an initial crack length of 100 mm and a_0 equal to 85 mm. Opening forces are applied to the specimens using loading blocks attached to one end of the specimen, as shown in Fig. 1a. The test speed was equal to 5 mm/min. For flax and hemp, the following G_{Ic} values were obtained: 676 and 642 J/m².

Subsequently, 4-point End Notched Flexure (4ENF) tests were performed to compute the Mode II interlaminar fracture toughness G_{IIc} , according to the ASTM D6272 standard. This is the same used for 4-point bending tests, with the only difference being the presence of an initial crack of 50 mm in

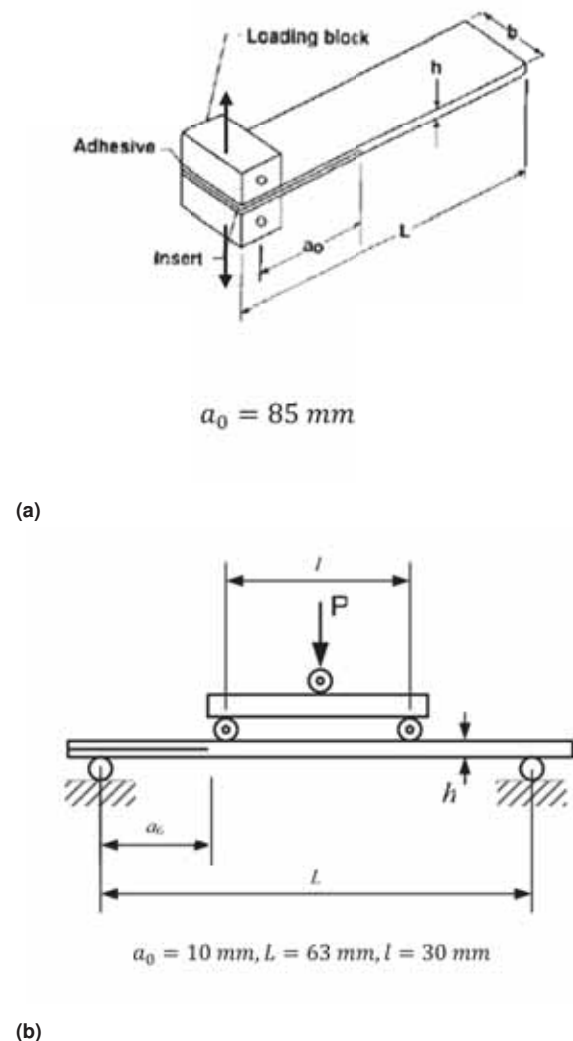

Figure 1. Schematic test representation for (a) DCB and (b) 4ENF tests¹⁸.

the specimen and a value for a_0 equal to 10 mm (see Fig. 1b). Rectangular specimens (130 mm x 20 mm) were used and the test speed was set to 2 mm/min. It is worth noting that for both these tests the initial crack was made exactly at half the thickness of the specimen. For flax and hemp, the following G_{IIC} values were obtained: 874 and 894 J/m^2 .

1.3 In-plane Crashworthiness

The experimental results discussed until now highlight that flax and hemp have more or less the same mechanical properties. Therefore, it was decided to perform in-plane crashworthiness tests only on flax. These tests were carried out at Instron, in Turin, to evaluate the crush energy absorption capabilities and investigate the failure modes under both quasi-static and dynamic conditions. The specimens are rectangular (100 mm x 150 mm) with one of the shorter sides having a sawtooth-shaped release feature as in Fig. 2a. To ensure that the specimen wouldn't break at the top, a reinforcement tab was added. Moreover, under quasi-static conditions, a 10 mm initial crack was done on the same side of the trigger. It helps to properly initiate delamination in the desired portion of the sample and to avoid undesirable failure modes such as tearing or buckling. This crack was not necessary for the dynamic case, for which both cracked and not-cracked samples were tested. The first ones were used to provide a comparison with the quasi-static case, while the others to validate the finite element numerical model. Since there is still no recognized standard for testing the in-plane crashworthiness of composite materials, the fixture used in this research is the one presented by Vigna et al. in ¹⁹. This anti-buckling fixture (Fig. 2b) was designed to perform in-plane compression tests on flat samples under both quasi-static and dynamic conditions. This device consists of four lateral steel columns that support the specimen for its full length and two shorter central steel columns coated with Teflon to better fix the specimen ^{19,20}. In particular, all these six columns leave an unsupported height in the lower part of the sample, where failure occurs, to avoid over-constraining and to leave enough space to remove debris and foils during failure. This distance between the end of the columns and the lower crash plate remains constant during the test: in our case 10 mm, but it can be changed to obtain different test configurations ²¹. The sample must be positioned so that the sawtooth is in the lower part to initiate failure in the unsupported part. The load is transferred to the plate through a flat circular impactor with a diameter of 70 mm, which hits the upper part of the specimen. For the quasi-static case, a universal testing machine with a speed of 10 mm/min and a clamping force of 4 kN was used. For the dynamic tests, instead, the impact mass is 23.39 kg, the initial velocity is 5.14 m/s, and the impact energy is 300 J, since it corresponds to the average energy absorbed by the specimen during the quasi-static tests.

2 Numerical modelling

The FE models for the above experimental tests were created using Altair HyperMesh software and simulated using the explicit finite element software LS-DYNA ⁷. In this work, the following material models were adopted: *MAT_ENHANCED_COMPOSITE_DAMAGE

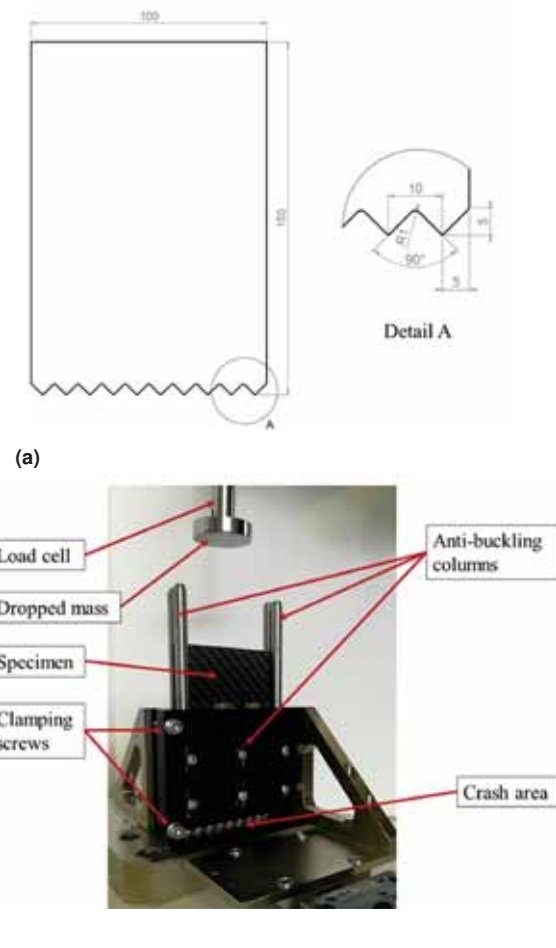

Figure 2. (a) Geometry of the specimens used for the in-plane crashworthiness tests, with trigger dimensions. (b) Anti-buckling fixture for compression crash testing of flat plates in impact conditions ¹⁹.

(*MAT54/55) which describes the laminate behavior, and *MAT_COHESIVE_MIXED_MODE (*MAT138) which models the cohesive layer. Since in this case woven fabrics were analyzed, the 2WAY flag was activated to correctly reproduce the 2-way fiber behaviour. The Chang-Chang failure criterion was here considered, as suggested in ^{7,22}. However, it is well known that there are some parameters in the definition of these numerical models that cannot be obtained from experimental tests. To overcome this issue, a trial-and-error procedure is approached to determine the unknown parameters.

The model for the DCB tests is shown in Fig. 3a: it consists of 440 fully-integrated solid elements, with a single element in thickness for each of the two half-laminates ¹⁸. The model was equipped, on the left side, with initial conditions of opening forces with constant velocity at the upper and lower edges, acting on the initial crack; on the right side, instead, translations and rotations were fixed as boundary conditions. This model is able to reproduce the progressive crack opening by gradual elimination of the failed cohesive elements at the interface. Fig. 3b shows the model for the 4ENF tests: compared to the model for DCB, no changes were made to the material, neither for the laminate nor for the cohesive elements.

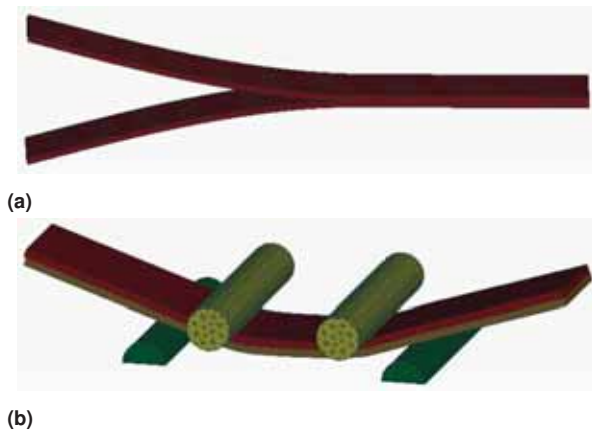

Figure 3. Finite element numerical models for (a) DCB and (b) 4ENF tests.

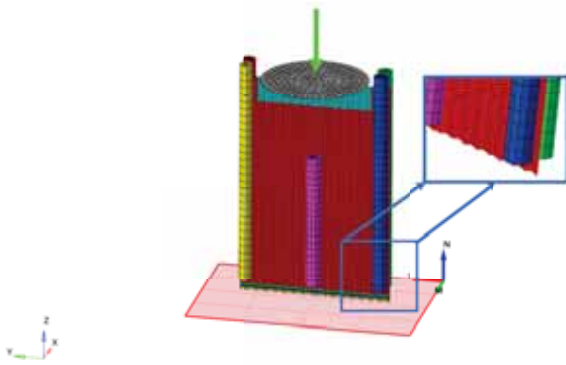

Figure 4. Numerical crashworthiness model with a close-up view of the single layer.

In modelling the in-plane crashworthiness test, the specimen is presented in a simplified configuration with a single shell layer since the main objective was to provide a first good approximation of the experimental tests. The numerical model is shown in Fig. 4. The obtained results are detailed enough to reproduce the laminate behavior with reasonable computational effort, even if the delamination phenomenon cannot be detected, as it will be described in the Section below. Also in this case, the *MAT54/55 material card is used for the laminate, while the *MAT20.RIGID modelled the steel columns of the fixture.

3 Results and discussion

In this section, the experimental and numerical results of the FE simulations on natural fiber composites are discussed in order to explain the behavior of the laminates and the different damage phenomena that characterize them. In particular, the approaches described in the previous Section are validated on flax and hemp laminates for DCB and 4ENF tests, while they are applied only to flax for in-plane crashworthiness tests due to their similar behavior.

For DCB and 4ENF tests, a comparison between the experimental and numerical results is shown in Figs. 5 and 6 in terms of load vs. opening plots. This comparison allows to set the parameters required by the MAT138 material card, whose values are collected in Table 3. Except for G_{Ic} and

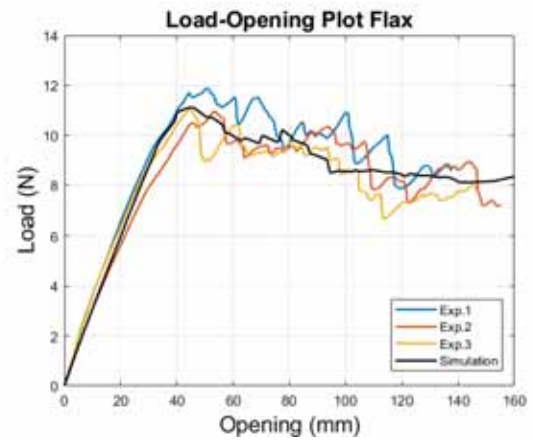

(a)

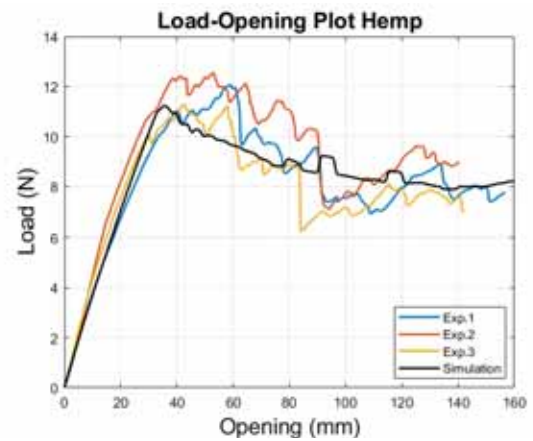

(b)

Figure 5. Comparison between experimental and numerical results of DCB test for (a) flax and (b) hemp laminates.

G_{IIc} , whose values come from the experimental tests, the others were obtained by trial and error.

A look at this plots highlights that the two numerical models (Figs. 3a, 3b) are able to reproduce well the experimental trends and also the delamination phenomenon.

On the other hand, for the in-plane crashworthiness tests, a first comparison between quasi-static and dynamic conditions for flax specimens oriented at 0° and 90° , was presented in Fig. 7, in terms of load vs. displacement plots. This choice is related to the need to understand the differences obtained performing a quasi-static or a dynamic test. From reviewing current literature, emerged that there exist two different crush failure modes: global splaying failure crush mode (GSF) and local fragmentation failure crush mode (LFF). This difference can be attributed to the strain-rate effect. In particular, when the specimen is loaded in a dynamic loading condition, intermolecular

Table 3. MAT138 Material properties. G_{Ic} and G_{IIc} are expressed in kJ/mm^2 , density in kg/mm^3 . For parameters description see⁷.

MAT_COHESIVE_MIXED_MODE (MAT138)		
RO	EN	ET
1.00 E-8	3.2	2
GIC	GIIC	UND = UTD
0.0007	0.0009	0.2

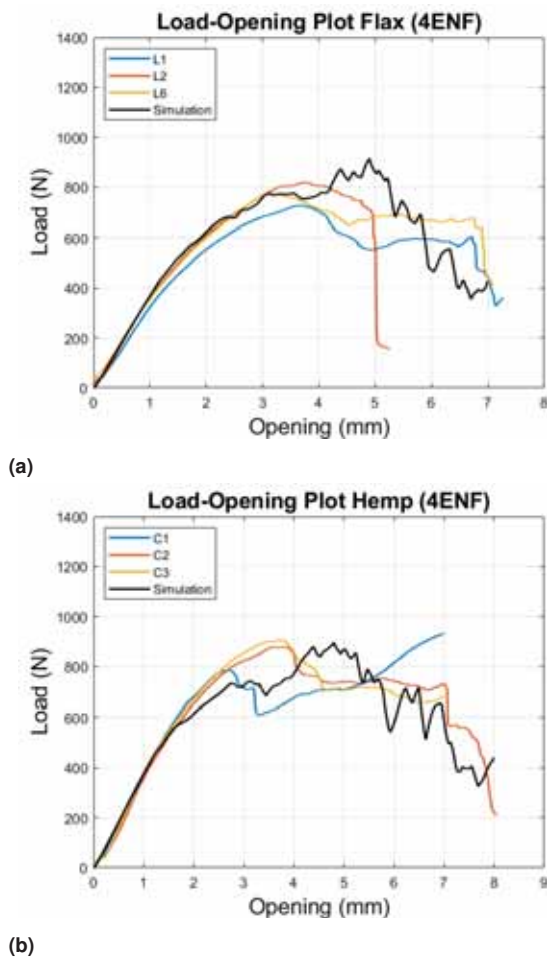

Figure 6. Comparison between experimental and numerical results of 4ENF test for (a) flax and (b) hemp laminates.

interactions between polymer chains are limited to a short time, resulting in a brittle failure. On the contrary, under quasi-static conditions, these interactions are extended to the intramolecular level, resulting in a ductile behavior.^{23,24}

Looking at the results in Fig. 7, it can be seen that the specimens crushed in a stable manner under dynamic conditions, since the variation of the force has a limited dispersion, and so it stands on a constant value. On the other hand, in the quasi-static case, the curves reach higher values of the acquired load, which are related to the variation of the fracture modes; in particular, this led to a major amount of absorbed energy, despite the reported instability. The failure mode is a mixture of frond formation of the outer layers and fragmentation of the remaining inner layers of the laminates, but some buckling phenomena are also observed, as shown in Fig. 8a. Under dynamic conditions, instead, no folding or local buckling is observed, as shown in Fig. 8b. Thus, the experimental results highlight the advantages of the dynamic tests, in which all the specimens follow a more stable crushing trend, suggesting that in-plane crashworthiness is the best for future applications and is more consistent with the actual application of these materials, which, for example, do not come into contact with static loads in the event of an accident. However, it is not always simple to perform dynamic tests, therefore it is important to quantify the variation in terms of energy absorption between the two conditions. The plots in Fig. 7

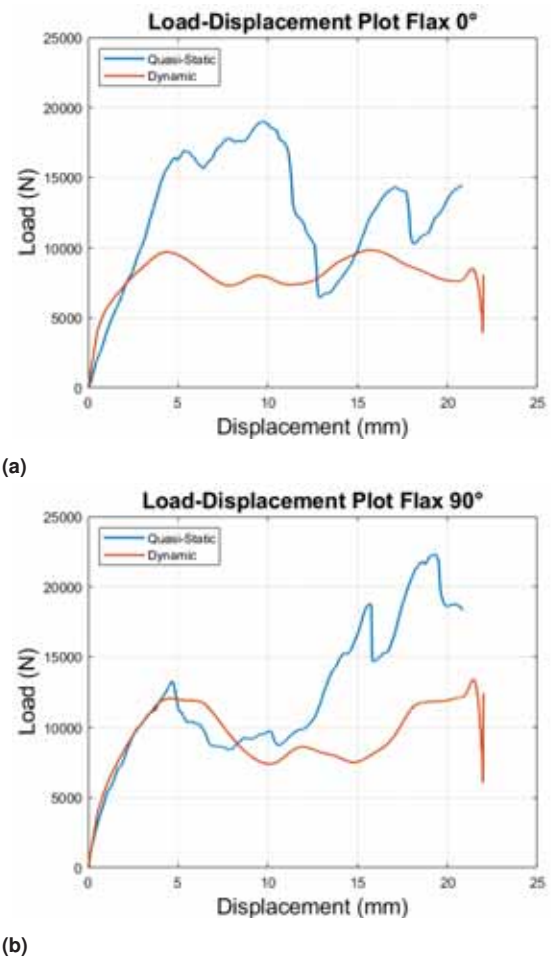

Figure 7. Experimental comparison between in-plane crashworthiness quasi-static and dynamic conditions for flax laminates at (a) 0° and (b) 90°.

provide a comparison in such sense, in presence of tabs and initial crack on the samples. In particular, an absorbed energy loss of almost 35% is observed in the transition from quasi-static to dynamic conditions. This suggests that, in the modeling phase of a component, it is necessary to take into account this loss of energy if quasi-static and dynamic conditions need to be compared.

Since for this work it was possible to perform both tests, only the dynamic case was numerically reproduced for flax specimens oriented at 0° and 90°. The results shown in Fig. 9 confirm the ability of the numerical model to reproduce well the experimental behavior, although it consists of a single shell layer. To confirm the validity of the model, Table 4 was added. It provided a comparison between experimental and numerical results in terms of absorbed energy and average force. A decreasing of almost 10% was registered in the numerical results with respect to

Table 4. Numerical vs. experimental comparison in terms of absorbed energy E_{abs} (J) and average force P_{av} (N). The reported values are averaged between 0° and 90°.

	E_{abs} (J)	P_{av} (N)
Experimental	275.8	12474
Numerical	248.9	11449



(a)



(b)

Figure 8. Damages under (a) quasi-static and (b) dynamic in-plane crashworthiness conditions.

the real trend. The experimental results were also filtered to reduce the high number of oscillations resulting from the test: this was done using a bandstop filter between 1 kHz and 40 kHz and a smoothing of 700 points. Due to the limited number of samples available, three tests for each material and orientation were performed under both conditions. However, since the aim is to compare quasi-static and dynamic trends, only one curve was shown as a reference. The numerical values required by the MAT54/55 material card were collected in Table 5. All the physical parameters required by the material card came from the experimental campaign, except for the maximum strain for fiber tension (DFAILT) and the maximum shear strain (DFAILS), whose experimental values were too small. Therefore, a trial-and-error approach was used to select the most appropriate values. The same strategy was used to determine the maximum longitudinal and transversal compression stresses (XC, YC) and strain (DFAILC), since they were not available from the experiments.

To properly reproduce the splaying phenomenon of the samples, a model with at least two layers connected by tie-break contacts or cohesive elements is required, and the authors are interested in investigating this aspect further.

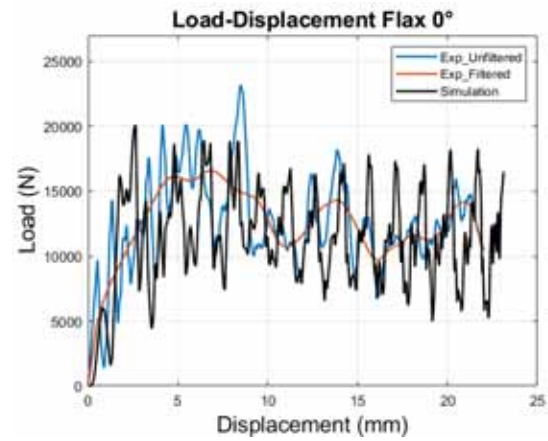

(a)

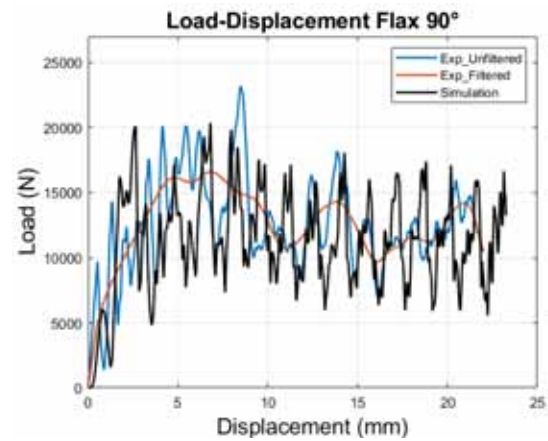

(b)

Figure 9. Comparison between experimental and numerical results of dynamic in-plane crashworthiness test for flax laminates at (a) 0° and (b) 90°.

4 Conclusions

Delamination and in-plane crashworthiness tests were first conducted on flax and hemp reinforced laminates, and then numerically modelled using FE.

The experimental campaign showed that these NFC exhibit interesting mechanical behavior. Therefore, among natural fibers, flax and hemp are good potential candidates for partial or total replacement of synthetic fibers in composites for structural components, also considering their availability and processability. After a proper material parameter tuning, the results of the numerical simulations were able to reproduce the experimental trends and capture the phenomena of fracture and delamination.

Table 5. MAT54/55 Material properties for flax laminates. Moduli and strengths are expressed in GPa, density in Kg/mm³. For parameters description see⁷.

MAT_ENHANCED_COMPOSITE_DAMAGE (MAT54/55)				
RO	EA	EB	PRBA	2WAY
1.30 E-6	17.8	17.8	0.17	1
GAB	GBC	GCA		
2.2	2.2	2.2		
DFAILS	DFAILT	DFAILC		
0.09	0.80	-0.50		
XC	XT	YC	YT	SC
0.1	0.16	0.1	0.16	0.084

The trial-and-error approach adopted in this study lead to identify the appropriate values for the material model parameters. A refinement of the identified values could be obtained by means of an optimization process in order to consider the global configuration and to include all the parameters involved in the material card that affect the FE model response. Once the model is well calibrated and detailed enough, FE simulations prove to be a valid tool for predicting the behavior of more complex structures in the mechanical design phase, before the test prototypes are manufactured. In view of future applications, further investigations will be conducted to numerically reproduce the in-plane crashworthiness test with a 2-layer shell model.

References

1. Topics for Environment, European Commission. https://environment.ec.europa.eu/topics_en.
2. Road transport: Reducing CO₂ emissions from vehicles. https://climate.ec.europa.eu/eu-action/transport_en.
3. Stewart, R. *Automotive composites offer lighter solutions*, Volume 54. Reinforced Plastics, 2010. doi:10.1016/S0034-3617(10)70061-8
4. Mohammed, L., Ansari, M.N.M., Pua, G., Jawaid, M., Islam, M.S. *A Review on Natural Fiber Reinforced Polymer Composite and Its Applications*. International Journal of Polymer Science, 2015. doi:10.1155/2015/243947
5. Colamartino, I., Pinato, E., Cavasin, M., Tagliabue, M., Anghileri, M., Boniardi, M. *Static, dynamic and impact properties of a high-performance flax-fiber composite*. Results in Materials, 2023. doi:10.1016/j.rinma.2023.100493
6. Del Bianco, G., Giammaria, V., Boria, S., Fiumarella, D., Ciardiello, R., Scattina, A., Belingardi, G., Castorani, V. *Flax and hemp composites: Mechanical characterization and numerical modeling*. Proceedings of the Institution of Mechanical Engineers, Part C: Journal of Mechanical Engineering Science, 2023. doi:10.1177/09544062231182036
7. LS-DYNA Keyword User's Manual, Vol II, Material Models, R13, Livermore Software Technology, 2021.
8. Maria Rosaria Ricciardi, Ilaria Papa, Valentina Lopresto, Andrea Calzolari, Lorenzo Vigna, Vincenza Antonucci, *Experimental characterization of the crashworthiness of carbon fiber reinforced epoxy composites*. Progress in Aerospace Sciences, 2024. doi:10.1016/j.paerosci.2024.101003
9. Zhang, Z., Sun, W., Zhao, Y., Hou, S. *Crashworthiness of different composite tubes by experiments and simulations*, Volume 143. Composites Part B: Engineering, 2018. doi:10.1016/j.compositesb.2018.01.021
10. Boria, S., Scattina, A., Belingardi, G. *Axial energy absorption of CFRP truncated cones*, Volume 130. Composite Structures, 2015. doi:10.1016/j.compstruct.2015.04.026
11. Isaac, C.W., Ezekwem, C., *A review of the crashworthiness performance of energy absorbing composite structure within the context of materials, manufacturing and maintenance for sustainability*, Volume 257. Composite Structures, 2021. doi:10.1016/j.compstruct.2020.113081
12. Capretti, M., Del Bianco, G., Giammaria, V., Boria, S. *Natural Fibre and Hybrid Composite Thin-Walled Structures for Automotive Crashworthiness: A Review*, Volume 17. Materials, 2024. doi:10.3390/ma17102246
13. Feraboli, P., Deleo, F., Garattoni, F. *Efforts in the Standardization of Composite Materials Crashworthiness Energy Absorption* 22nd American Society for Composites Technical Conference, 2007.
14. Feraboli, P. *Development of a Corrugated Test Specimen for Composite Materials Energy Absorption*, Volume 42. Journal of Composite Materials, 2008. doi:10.1177/0021998307086202
15. Feraboli, P., Wade, B., Deleo, F., Rassaian, M., Higgins, M., Byar, A. *LS-DYNA MAT54 modeling of the axial crushing of a composite tape sinusoidal specimen*, Volume 42. Composites: Part A, 2011. doi:10.1016/j.compositesa.2011.08.004
16. Vigna, L. *Development of an innovative procedure to assess the crashworthiness of composite materials*. Doctoral Dissertation Doctoral Program in Mechanical Engineering, 2023.
17. Garg, R., Babaei, I., Paolino, D.S., Vigna, L., Cascone, L., Calzolari, A., Galizia, G., Belingardi, G. *Predicting Composite Component Behavior Using Element Level Crashworthiness Tests, Finite Element Analysis and Automated Parametric Identification*, Volume 13. Materials, 2020. doi:10.3390/ma13204501
18. Belingardi, G., Boria, S., Scattina, A. *Delaminazione sperimentale e numerica di laminati in composito*. AIAS, 40° Convegno Nazionale, 2011.
19. Vigna, L., Calzolari, A., Galizia, G., Belingardi, G., Paolino, D.S. *Effect of friction on a crashworthiness test of flat composite plates*, Volume 6. Forces in Mechanics, 2022. doi:10.1016/j.finmec.2021.100070
20. Babaei, I., Garg, R., Vigna, L., Paolino, D.S., Belingardi, G., Cascone, L., Calzolari, A., Galizia, G. *Newly Developed Anti-Buckling Fixture to Assess the In-Plane Crashworthiness of Flat Composite Specimens*, Volume 10. Applied Sciences, 2020. doi:10.3390/app10217797
21. Vigna, L., Calzolari, A., Galizia, G., Belingardi, G., Paolino, D.S. *Effect of impact speed and friction on the in-plane crashworthiness of composite plates* Volume 33. Procedia Structural Integrity, 2021. doi:10.1016/j.prostr.2021.10.069
22. Rabiee, A., Ghasemnejad, H. *Finite Element Modelling Approach for Progressive Crushing of Composite Tubular Absorbers in LS-DYNA: Review and Findings*, Volume 11. Journal of Composites Science, 2022. doi:10.3390/jcs6010011
23. David, M., Johnson, A.F., Voggenreiter, H. *Analysis of crushing response of composite crashworthy structures*, Volume 20. Appl Compos Mater, 2013. doi:10.1007/s10443-012-9301-8
24. David, M., Johnson, A.F. *Effect of strain rate on the failure mechanisms and energy absorption in polymer composite elements under axial loading*, Volume 122. Composite Structures, 2015. doi:10.1016/j.compstruct.2014.11.010