

Assessment of a Brain Stroke Microwave Scanner Based on Off-the-Shelf Solid-State Switching

Original

Assessment of a Brain Stroke Microwave Scanner Based on Off-the-Shelf Solid-State Switching / Gugliermine, M.; Rodriguez-Duarte, D. O.; Origlia, C.; Tobon Vasquez, J. A.; Bolomey, J. C.; Scapatucci, R.; Crocco, L.; Vipiana, F.. - ELETTRONICO. - (2024), pp. 281-282. (Intervento presentato al convegno 2024 IEEE INC-USNC-URSI Radio Science Meeting (Joint with AP-S Symposium) tenutosi a Firenze (Italy) nel 14-19 July 2024) [10.23919/inc-usnc-ursi61303.2024.10632247].

Availability:

This version is available at: 11583/2992303 since: 2024-09-16T07:51:16Z

Publisher:

IEEE

Published

DOI:10.23919/inc-usnc-ursi61303.2024.10632247

Terms of use:

This article is made available under terms and conditions as specified in the corresponding bibliographic description in the repository

Publisher copyright

IEEE postprint/Author's Accepted Manuscript

©2024 IEEE. Personal use of this material is permitted. Permission from IEEE must be obtained for all other uses, in any current or future media, including reprinting/republishing this material for advertising or promotional purposes, creating new collecting works, for resale or lists, or reuse of any copyrighted component of this work in other works.

(Article begins on next page)

Assessment of a Brain Stroke Microwave Scanner Based on Off-the-Shelf Solid-State Switching

M. Gugliermi⁽¹⁾, D. O. Rodriguez-Duarte⁽¹⁾, C. Origlia⁽¹⁾, J. A. Tobon Vasquez⁽¹⁾, J. C. Bolomey⁽²⁾⁽³⁾, R. Scapaticci⁽⁴⁾, L. Crocco⁽⁴⁾, and F. Vipiana⁽¹⁾

⁽¹⁾ Dept. Electronics and Telecommunications, Politecnico di Torino, Torino, Italy (francesca.vipiana@polito.it)

⁽²⁾ Université Paris-Saclay, Paris, France

⁽³⁾ eV-Technologies, Caen, France

⁽⁴⁾ Institute for Electromagnetic Sensing of the Environment, National Research Council, CNR, Naples, Italy

Abstract—This work presents the preliminary experimental validation of an updated device for brain stroke imaging using an off-the-shelf solid-state-based switching network interfacing with a four-port transceiver system with twenty-two radiating elements. These are custom-made wearable antennas placed around the head. The testing consists of an in-lab simulated, simplified hemorrhage condition mimicked with realistic anthropomorphic phantoms. The system showcases its proficiency for real-time tracking of the stroke evolution via 3-D contrast dielectric maps. It employs multi-view and single-frequency data collected at 1 GHz, processed with a differential linear inversion imaging algorithm based on the distorted Born approximation and truncated singular value decomposition (TSVD). The study outcomes verify the imaging capabilities of the system. They are a crucial milestone toward implementing a low-complexity, compact, portable microwave scanner for brain stroke imaging to monitor stroke evolution in clinical scenarios.

I. INTRODUCTION

Stroke is a cerebrovascular accident that remains a major global health concern due to its profound impact on individuals' well-being and, in severe cases, its life-threatening consequences [1]. Prompt medical attention is crucial when a stroke is suspected, as timely and adequate intervention can minimize brain damage and improve the chances of recovery. However, the early detection and monitoring of strokes are medical paramount and hardly approachable with the current image-based diagnostic standard: magnetic resonance (MRI) and computed tomography (CT). Their drawbacks leave open complementary on-develop medical support alternatives such as microwave imaging (MWI) [2], [3].

MWI is a non-invasive and safe option for repeated examinations, which relies on the ability of microwaves to penetrate biological tissues without ionizing radiation and its sensitivity to physiological variations induced by strokes in the dielectric properties of brain tissues. A MWI system analyzes the back-scattered response of a region of interest when exposed to an electromagnetic (EM) field at microwave frequencies, retrieving a spatial distribution of the electric contrast within the examined area via imaging algorithms [4]–[7].

This work introduces and preliminary validates an updated version of the MWI scanner introduced in [8], in which the electromechanical switches are replaced with off-the-shelf solid-state-based. This accelerates the switching time speed, enhances the portability and stability of the system, and

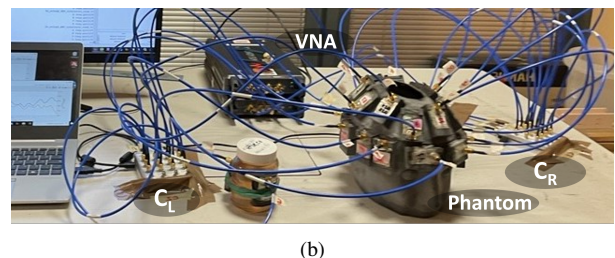
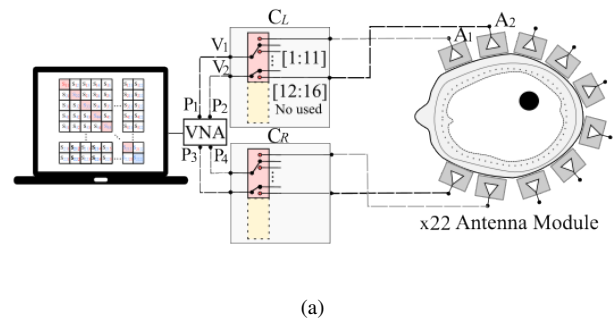

Fig. 1. Scheme of the 4×22 MWI system architecture: (a) scheme of the device and (b) image of the set-up in the laboratory.

extends its durability and lifespan. In the following, we detail the upgraded hardware implementation, the experimental validation, and the imaging results.

II. MICROWAVE SCANNER ARCHITECTURE

The microwave scanner comprises a 4-port transceiver system implemented with two Vector Network Analyzer (VNA), P9375A Keysight Streamline USB VNA in a parallel configuration [9], providing the stimulus and receiving the response. It is connected to a pair of 4×16 correlators (EVT1016) [10], a solid-state switching matrices, interfacing with twenty-two antennas conformally positioned on the head [8] as illustrated in Fig. 1. Here, it is worth noticing that the implemented architecture partially used each matrix's available channels for the sake of the application but could be extended up to 32 output channels.

Then, the switches present a switching time of approximately 10 ms, isolation below the -80 dB between channels, and repeatability variation on the order of 0.01 dB under the

same conditions. Hence, the new version needs a shorter stabilization time after each cycle than electromechanical switches, i.e., each time the selected transmitting and receiving antennas are changed. This helps reduce the acquisition time, although it remains constrained by the intermediate filter (IF) of the VNA. The VNA is set with an input power of 0 dBm and the IF to 100 Hz. As two correlators are employed, the process begins by individually acquiring two 11×11 scattering matrices from each one, C_L and C_R in the scheme, L and R standing for left and right, respectively. Subsequently, two additional 11×11 matrices are built by combining the data acquired from C_L and C_R . Then, the four parts are merged to form a 22×22 scattering matrix.

III. EXPERIMENTAL VALIDATION

For the validation, we replicate the experiment outlined in [8], focusing on a case mimicking an evolution between a healthy condition and a 15 mm^3 hemorrhage placed on the middle back part of the right brain lobe. The head is modeled with an anthropomorphic plastic container filled with an alcohol-based liquid with the average permittivity and conductivity of the brain, $\epsilon_r = 45$ and $\sigma = 0.8$ [S/m] at 1 GHz, respectively, which are characterizing using the Keysight “N1500a materials measurement suite” software [11]. Then, the imaging is tested using the differential scheme described in [7], retrieving the images in real-time. We use 1 GHz considering resolution and penetration, following the procedure described in [12]. This approach exploits the “weak” and localized stroke nature to linearize the problem via a distorted Born approximation while inverting and regularizing it using a truncated singular value decomposition (TSVD) algorithm [13]. Thus, by adopting these techniques, we address non-linearity, providing instantaneous feedback, a crucial advancement in meeting medical needs for effective stroke monitoring and timely interventions.

Figure 2 shows the system’s capabilities to detect and localize the affected area (yellow zone) correctly, providing a visual representation where (a) illustrates the 3-D render of the normalized differential dielectric contrast amplitude above -3 dB and (b) is a transverse slide of the 3-D retrieved map center in the middle of the stroke region.

IV. CONCLUSION AND PERSPECTIVES

This study evaluated a compact, low-complexity MWI system for brain stroke monitoring in which the switching network is updated with an off-the-shelf solid-state one. Thanks to these switches, as compared to electromechanical ones, there is an increased switching speed and greater device compactness while the imaging capabilities are kept. For future work, the aim is to expand the measurement campaign, exploring continuous monitoring of stroke and employing a multi-tissue phantom [14] to create an experimental setup that closely mimics real-world conditions.

ACKNOWLEDGEMENT

This work was supported in part by the project PON Research and Innovation “Microwave Imaging and Detection

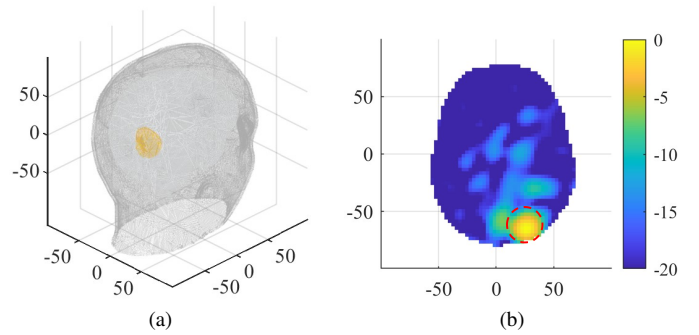

Fig. 2. Normalized differential dielectric contrast amplitude: (a) 3-D render of values above -3 dB , and (b) transverse view sliced in the middle of the stroke region. Colorbar in [dB]. The dotted contour indicates the estimated position of the stroke.

powered by Artificial Intelligence for Medical and Industrial Applications (DM 1062/21)”, funded by MUR. It was carried out partially within the Agritech National Research Center, funded by the European Union Next-Generation EU (Piano Nazionale di Ripresa e Resilienza (PNRR) – MISSIONE 4 COMPONENTE 2, INVESTIMENTO 1.4 – D.D. 1032 17/06/2022, CN00000022). We thank eV-Technologies, for the fruitful discussion and providing us with the correlators.

REFERENCES

- [1] C. W. Tsao et al., “Heart disease and stroke statistics—2022 update: a report from the american heart association”, *Circulation*, vol. 145, no. 8, pp. e153–e639, 2022.
- [2] Fhager et al., “Microwave diagnostics ahead: Saving time and the lives of trauma and stroke patients”, *IEEE Microwave Magazine*, vol. 19, pp. 79–90, 2018.
- [3] L. Guo et al., “Stroke diagnosis using microwave techniques: Review of systems and algorithms”, *IEEE Journal of Electromagnetics, RF and Microwaves in Medicine and Biology*, pp. 1–14, 2022.
- [4] L. Guo et al., “Adaptive clustering distorted born iterative method for microwave brain tomography with stroke detection and classification,” *IEEE Transactions on Biomedical Engineering*, , vol. 69, no. 4, pp. 1512–1523, 2022.
- [5] A. Fedeli et al., “Nonlinear s-parameters inversion for stroke imaging,” *IEEE Transactions on Microwave Theory and Techniques*, , vol. 69, no. 3, pp. 1760–1771, 2021.
- [6] Ilja Merunka et al., “Microwave Tomography System for Methodical Testing of Human Brain Stroke Detection Approaches,” *Hindawi International Journal of Antennas and Propagation*, vol. 2019 Article ID 4074862, pp. 1-9, 2019.
- [7] D. O. Rodriguez-Duarte et al., “Experimental validation of a microwave system for brain stroke 3-d imaging,” *Diagnostics*, vol. 11, no. 7, 2021.
- [8] D. O. Rodriguez-Duarte et al., “Experimental Assessment of Real-Time Brain Stroke Monitoring via a Microwave Imaging Scanner”, *IEEE Open Journal of Antennas and Propagation*, vol. 3, pp. 824–835, 2022.
- [9] “Keysight.” Available at <https://www.keysight.com/us/en/product/P9375A/streamline-usb-vector-network-analyzer-26-5-ghz.html>.
- [10] “Dual EVT1016”, eV Technologies Available at <https://ev-technologies.com/portfolio-items/dual-evt1016/>.
- [11] “N1500a materials measurement suite.” Available at <https://www.keysight.com/it/en/product/N1500A/materials-measurement-suite.html>.
- [12] Scapatucci, Rosa, et al. “Design and numerical characterization of a low-complexity microwave device for brain stroke monitoring”, *IEEE Transactions on Antennas and Propagation*, 66(12), pp. 7328-7338, 2018.
- [13] M. Bertero and P. Boccacci, “Introduction to inverse problems in imaging” *CRC Press*, 1998.
- [14] C. Origlia, M. Gugliermi, D. O. Rodriguez-Duarte, J. A. Tobon Vasquez, F. Vipiana, “Anthropomorphic Multi-tissue Head Phantom for Microwave Imaging Devices Testing”, *European Conference on Antennas and Propagation (EuCAP)*, pp. 1–4, 2023.