

Design of an Integrated Monitoring System for Multiple-Unit Freight Trains

*Original*

Design of an Integrated Monitoring System for Multiple-Unit Freight Trains / Gurri', Simona; Zara, Gilberto; Di Paola, A.; Dalla Chiara, B.. - ELETTRONICO. - 7:(2024), pp. 1-15. (Intervento presentato al convegno The sixth international conference on railway technology: research, technology and maintenance tenutosi a Prague (CZ) nel 1-5 September 2024) [10.4203/ccc.7.8.3].

*Availability:*

This version is available at: 11583/2992207 since: 2024-09-04T10:15:08Z

*Publisher:*

Computational & Technology Resources

*Published*

DOI:10.4203/ccc.7.8.3

*Terms of use:*

This article is made available under terms and conditions as specified in the corresponding bibliographic description in the repository

*Publisher copyright*

(Article begins on next page)



Proceedings of the Sixth International Conference on  
Railway Technology: Research, Development and Maintenance  
Edited by: J. Pombo  
Civil-Comp Conferences, Volume 7, Paper 8.3  
Civil-Comp Press, Edinburgh, United Kingdom, 2024  
ISSN: 2753-3239, doi: 10.4203/cc.7.8.3  
©Civil-Comp Ltd, Edinburgh, UK, 2024

# Design of an Integrated Monitoring System for Multiple-Unit Freight Trains

**S. Gurri<sup>1</sup>, G. Zara<sup>2,1</sup>, A. Di Paola<sup>2</sup> and B. Dalla Chiara<sup>1</sup>**

<sup>1</sup> **Department of Transport and Infrastructure Engineering DIATI,  
Politecnico di Torino Italy**

<sup>2</sup> **Engineering division, Alstom SA Savigliano (CN), Italy**

## Abstract

Lately the world of passenger rail transport has undergone profound changes that have brought rail back to the centre of both policy and market attention. However, rail is now facing another revolution: policies are pushing toward a modal shift for freight as well, hoping to increase rail modal share by tapping into a larger pool of freight (e.g. refrigerated goods) and make it more sustainable both on an environmental and social level. To fulfil this purpose, freight trains must take advantage of existing high-speed infrastructure designed for promiscuous use, but only used for passengers. A necessary condition toward this goal is for the trains to be equipped with monitoring systems that enable the rolling stock to be continuously diagnosed in order to increase their safety, quality, and reliability. In this paper, after providing an overview of the Technical Specification for Interoperabilities applied on passenger trains in Europe and of the needs of the freight market, an innovative monitoring system for the next generation high-speed freight electric multiple unit is designed with a model based systems engineering approach, defining functional, logical and physical architectures. Then its future technological implications are evaluated, in a context where artificial intelligence is increasingly central in all industries, especially in predictive maintenance.

**Keywords:** freight train, monitoring, system architecture, model based system engineering, accident prevention, safety equipment, machine learning.

# 1 Introduction

The world of freight trains has stagnated for decades. Passenger trains, on the other hand, have made great leaps forward over the past years, transforming from being purely mechanical jewels to complex *Cyber-Physical Systems* (CPSs). Embedded systems ensure better performance, reliability, and continuous monitoring of the train's status for a more efficient service. The fourth industrial revolution has brought unexpected technologies, such as low-cost sensor technology, high-bandwidth digital communication systems (4G and 5G) and new data analytic techniques. If the world of passenger trains, especially *high-speed* (HS) trains, is gradually adopting these technologies, freight rail transport has lagged, only now envisaging small steps toward digitization, yet insufficient for it to be a driver of a modal shift. Due to this backwardness, freight transport still relies on road transport, which, by contrast, has benefited from considerable investment in research and development, becoming steadily more competitive and cost-effective. It must be a stimulus for the rail logistics sector to create technologies that endorse it by becoming a demand attractor.

This work is intended to be placed within this framework: it aims at proposing a new technology that constitutes a building block to the generational leap of freight trains, which, in approaching new shares of the market, need to change their paradigm, becoming *Freigh-Electric Multiple Units* (F-EMUs). Taking inspiration from passenger EMUs, which successfully redirected the modal share from car or air to rail, the objective is to develop a freight train capable of exploiting the remaining capacity of HS lines, which in most of Europe, are built for mixed-use, but currently only used for passenger traffic. The intended outcome is not achieving freight trains capable of operating on the lines at speeds of 250-340 km/h, but rather ensuring they own characteristics such as reliability, availability, maintainability, safety, and security. They would offer attractive and comprehensive services even when running at only 160 km/h, a speed still higher than road transport, facilitating the exploitation of intermodal transport. To reach this objective, it's crucial to pinpoint the challenges in railway freight haulage and leverage technology to drive further advancements.

Hence, this paper discusses the possibility of using an *integrated Bogie Monitoring System* (BMS) architecture - based on one already in use on Alstom's passenger EMUs - on *innovative* F-EMU. "Innovative" refers to the introduction of new systems aimed at monitoring dynamic parameters related to rolling stock, enhancing competitiveness and reducing transport costs/disruptions through predictive maintenance techniques. Conversely, "integrated" describes a unified sensor framework where signals are consolidated into a central unit (referred to as *Bogie Monitoring Equipment* (BME)), enabling efficient information processing and interaction with the *Train Control Management System* (TCMS).

The contribution of this work is twofold: first, the possibility of using the platform of an Alstom's passenger HS EMU, already natively equipped with BMS in compliance with TSI LOC and PAS 1302/2014/EU (1), reconverted to the transport of groupage-type freight (named *Passenger to Freight Electric Multiple Unit*

(P2F-EMU)) was investigated, similarly to what Mercitalia Rail did in 2018 with Mercitalia Fast; in this case, additional sensors are implemented to monitor the cargo. Secondly, modelling the integration of BMS onto the new-generation distributed power freight electric train, known as the F-EMU, developed at *Politecnico di Torino*, has been undertaken. Distinctions exist between the two architectures, especially concerning the diverse load modes on the P2F-EMU and the F-EMU. Following the identification of system needs and requirements, architectures were formulated, accompanied by a list of technical specifications pertinent to sensor implementation.

The paper is structured as follows: it begins with an introduction, followed by Sec. 2 discussing state-of-the-art technologies in rail freight transport, and Sec. 2.2 detailing the main characteristics of the considered trains. The methodology is outlined in Sec. 3, covering the collaboration with Alstom for designing the bogie monitoring system. Section 4 elaborates on requirements, functional models (Sec. 4.1 and Sec. 4.2), and progresses to logical and physical architectures (Sec. 4.3 and Sec. 4.4). Section 5 analyzes the signals collected by the monitoring system, while Sec. 6 proposes new research directions and highlights the development of the analyzed rolling stock.

## 2 State of the art

In the last four to five decades, freight transport requirements and methods have evolved unfavorably for trains. Road transport, its primary competitor, has experienced advancements enhancing its commercial speed, safety, and competitiveness. This progress stems from innovations in engine efficiency, vehicle technology, and the implementation of tracking and monitoring systems for the cargo. One significant drawback of rail cars is their lack of onboard electricity. This limitation results in numerous outdated features specific to rail freight transport. However, this obsolescence hasn't impacted passenger transport, making a converted passenger electric train an optimal starting point for technological advancements in rail freight transport, albeit with limitations. These conversions may not cater to a wide range of transport needs due to space constraints and the ability to load only groupage. Repurposing outdated high-speed (HS) trains as freight trains could enhance the environmental sustainability of this mode, especially considering the potential for life extension. Instead of refurbishing, which would compromise fleet comfort due to outdated trains, inspiration can be drawn from practices in the aviation industry. Since the early 21st century, the demand for freight transport has expanded. This includes not only the transport of goods with diffuse traffic and low unit value but also a wider array of items such as consumer goods and e-commerce products, necessitating increased precautions during transit. This trend aligns with the use of intermodal transport units like containers, swap bodies, and trailers. Furthermore, in accordance with European guidelines (2), there's a growing necessity to assemble longer and heavier trains to lower unit transport costs, which strains the mechanical capabilities of wagons. Consequently, there's a need for train monitoring to minimize breakdowns and optimize maintenance.

## 2.1 Railway Freight Market Analysis

So far, the majority of sector players have favored maintaining the fundamental layout of rail cars while implementing wagon monitoring systems to facilitate supervision of car body systems and integrity. These innovative solutions rely on small, typically self-powered sensors to monitor various aspects of vehicle dynamics. In Italy, the state-owned company Mercitalia Rail, in collaboration with TX Logistik (both part of the Ferrovie dello Stato Group), has initiated a pilot project known as Smart Train (3). This project tests online monitoring technologies for parameters such as bearing condition, bogie condition, braking system, and semi-trailer saddle monitoring. Data can be stored or transmitted wirelessly.

Further exploration into aspects related to the braking system and driving dynamics can be found in studies by Zanelli et al. (4; 5), which detail the measurement campaign conducted. Similarly, Wang et al. (6) delve into predictive diagnostics based on brake system analysis. Another study by Wang et al. (7) focuses on monitoring wagons' attitudes using gyroscopes to prevent accidents such as sidetracks and rollovers. Furthermore, a study conducted by Alstom in collaboration with Politecnico di Torino (8) highlights the potential benefits of implementing condition-based maintenance (CBM) over traditional maintenance cycles based on predetermined kilometers traveled or hours spent.

More recently, the demand for enhanced data harvesting systems has led to the development of integrated platforms managing various aspects of train monitoring. An example of this is Hitachi's application of an integrated platform for monitoring wheelsets on GWR's high-speed (HS) passenger trains (9), which includes a set of sensors transmitting live data wirelessly about bogie components to improve maintenance cycles, safety, and train availability. However, solutions incorporating onboard monitoring systems are noted to be more flexible and robust (10; 11; 12).

Other significant considerations involve monitoring the temperature of axle boxes and the yaw motion of bogies (bogie hunting). While *Hot Axlebox Detection Pointss* (HADPs) already exist in rail infrastructure, placed at specific points along the line, bogie hunting phenomenon, stemming from tapered wheels, requires continuous monitoring and restriction due to its dual nature of normality and potential harm. However, HADPs have limitations as they only detect temperature at specific points on the line, such as near long descents, rather than continuously.

Moreover, the 2014 TSI mandate vehicles traveling at speeds  $\geq 250\text{km/h}$  to install an onboard *Hot Axlebox Detection System* (HABD) and a bogie hunting detection system *Yaw Detection System* (YDS) (1). While this regulation doesn't directly apply to freight trains, it becomes mandatory for trains capable of speeds  $\geq 250\text{km/h}$ , such as the P2F-EMU. Nonetheless, these systems are foreseen on the F-EMU for monitoring and safety purposes. Additionally, a traditional EMU has relatively low axle masses (ranging from 15 t/axle in category A to 17.5 t/axle in B), while a freight train can exceed 22 t/axle in category D4. This higher axle mass significantly impacts infrastructure and necessitates continuous monitoring of running dynamics.

## 2.2 Rolling stock evolutions

The research effort brought into this paper is not intended to suffer from limitations concerning the power source of the proposed monitoring platform, and this is for two main reasons:

1. Many monitoring systems for freight trains already feature a system for generating the energy needed to power the equipment, such as small solar panels (4) or axial generators (13), and the scope of this paper is not to propose one;
2. The implementation of this platform is tailor-made for new generation freight trains, such as converted passenger electric trains, P2F-EMUs, and new generation distributed power freight trains, F-EMUs, both of which already feature a power source onboard the wagons.

To delve further into this aspect, it's worth mentioning the experiments conducted by Mercitalia Rail, British Railways, and SNCF, which involve converting a high-speed (HS) passenger electric train to transport groupage and postal parcels. Specifically, in this paper, the reference for the P2F-EMU is the *Pedolino* ETR-675 manufactured by Alstom SA, hypothetically repurposed for transporting palletized goods. Regarding the F-EMU, we consider an architecture currently being studied at Politecnico di Torino, where research has already been published on its operation on certain Italian lines (14; 15). The overall architecture comprises a modular trainset consisting of modules of 3 wagons based on the latest-generation T3000e intermodal wagon. Each module retains the following characteristics:

- 4 motor axles, corresponding to an adhesion factor of 33%;
- electro-pneumatic (with disc brakes) and electro-dynamic braking;
- intermodal freight, featuring containers and swap-bodies;
- axial load of  $17.5t/axle$  (*cat.B*) and up to  $22.5t/axle$  (*cat.D*);
- high voltage *Digital Automatic Coupler* (DAC);
- possibility to carry both traditional and reefer goods, aiming for high-value goods;
- interoperability on all standard  $1435mm$  gauge European railways;
- possibility to run on HS lines at  $160km/h$ .

## 3 Methodology

### 3.1 Aim and scope

The objective of this paper is to propose the design of the bogie monitoring subsystem for freight trains utilizing *Model Based Systems Engineering* (MBSE) (16), ensuring a systematically validated and verifiable design. This subsystem is pivotal for the operation of these trains on HS lines, as standards mandate the monitoring of rolling stock. The necessity to exploit HS lines stems from their latent capacity, allowing freight trains to operate during off-peak hours, and the potential to attract modal shift

to rail with faster new-generation trains capable of transporting various goods safely, facilitated by the monitoring system (15). Thus, there is a clear need for sustainable, long-term innovations to replace existing systems that fail to address modal choice issues despite their cost-effectiveness.

The modernization of the freight train fleet must align with current technological trends, transitioning them into CPS that interact not only with each other but also with the infrastructure. To achieve this goal, market demands, the requirements of rolling stock manufacturers, and prevailing regulations in Europe were assessed to develop an interoperable, intermodal, and sustainable freight train.

### 3.2 Proposed approach

The proposed approach is therefore based on Complex Systems theory and in particular MBSE, which makes it possible to trace requirements and needs and automatically validate the analysis through formalization. The approach used is mixed: the needs are collected through qualitative analysis of supply and demand. These needs and requirements are first expressed in natural language and then transposed into formal language to eliminate all the ambiguities. This allows the hierarchy of functions to be identified and the functional decomposition to be performed. Thus, functions are characterized formally, and their attributes are expressed by the assignment of performance, efficiency, and constraints requirements.

Consequently, the design is created, via Mathworks (17) System Composer, in such a way as to establish traceability between system requirements and functional and behavioural elements. The physical architecture relates to the logical one, which in turn descends directly from the functional one. Here the functional analysis is done at a high level, without an excessively deep decomposition of functions. The depth is inferred from the operational scenarios produced by the analysis of a typical mission for the identified subsystem and from the knowledge of the pool of physical components from which it is possible to draw. Writing the system specifications and building the architectures constitutes the descending branch of the V model (18) of the system life-cycle development process.

The approach is presently undergoing further examination, focusing on formal test case development for system commissioning. Given the safety-critical nature of this CPS, formal methods are essential. After defining requirements and functions using formal methods, it is also imperative to formally establish inputs and outputs, enabling the tracking of various features throughout the design process. Formal methods offer rigorous verification of system properties, which cannot be achieved through empirical means alone, often proving too costly (*e.g.* building a prototype). As previously mentioned, physical components are sourced from an existing pool within the rail manufacturing industry. This strategy leverages economies of scale and mitigates maintenance procurement challenges. Such an approach aligns with Industry 4.0 principles and *Just In Time* (JIT) practices, facilitating lean processes.

## 4 Design of an innovative monitoring system

As discussed earlier, an integrated and innovative monitoring system would enable the F-EMU to operate on mixed-use HS lines, optimizing travel time and utilizing the remaining capacity of these lines. Beyond this capability, the system serves various functions including cargo control to attract high-value commodities, implementing cost-saving maintenance techniques, and enabling automatic wagon guidance at freight terminals for faster loading and unloading without third-party shunting services. With higher investment costs than a conventional train, the commercial marginal utility of the F-EMU is to be found in these features. Moreover, equipping the train with integrated monitoring systems could benefit the infrastructure manager by providing data on rail line health. This data could incentivize reduced tolls on HS lines for these trains, ultimately lowering specific transport costs.

To design such a system, it is imperative to address the main issues outlined in 2 and derive the primary requirements, which will serve as the foundation for applying the MBSE approach. By doing so, the architecture can effectively address market needs, bridging the technological gaps prevalent in traditional railway freight transport. This innovative approach revitalizes the rail sector, enhancing its competitiveness and expanding transport offerings. Leveraging the platform's innovative potential attracts greater demand while concurrently reducing transport costs through the implementation of more efficient maintenance cycles, facilitated by condition-based maintenance and predictive maintenance techniques, aided by the use of *Artificial Intelligence* (AI).

### 4.1 Requirements

This section collects the requirements of the integrated monitoring system of a high or medium-high-speed freight train.

First of all, as far as HS rail transport is concerned, the *Technical Specification for Interoperability* (TSI) 2014 (1) is taken as a reference. It requires equipping the train-set with systems for bogie hunting detection (YDS) and HADB.

Another requirement is to enhance the maintainability and availability of the train to improve its profitability. This necessitates continuous monitoring of certain subsystems deemed most safety-critical by train manufacturers, such as the electric motors, gearbox, and bogie structure. Presently, human resources analyze this data, prompting the need to boost efficiency and interpretability by employing machine-hours for analysis instead. As machine learning algorithms advance, predictive maintenance can be included as a sub-requisite, significantly reducing costs and optimizing maintenance cycles to enhance train maintainability and availability.

Furthermore, there's a need to enhance safety and security, both for cargo and train operations, mitigating potential failures. To attract higher-value commodities, cargo must undergo thermal and integrity control, coupled with near-point tracking of location over time.

As the demand for innovation persists, despite the time required to raise its *Technology*



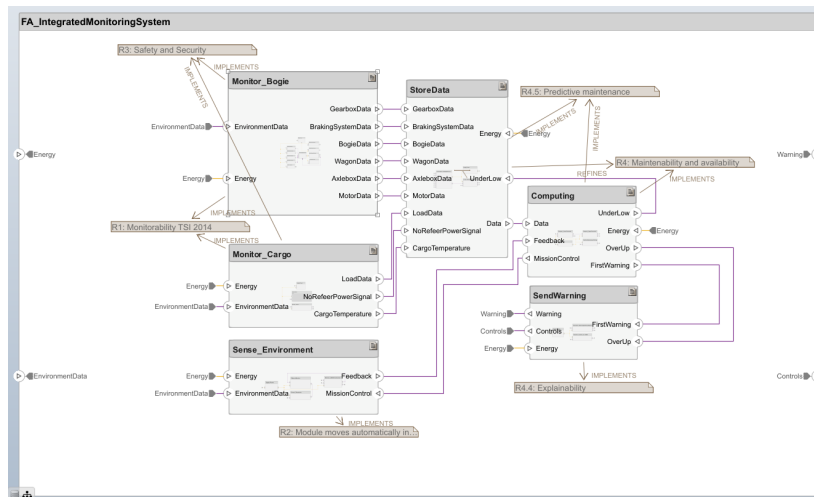

Figure 1: Functional Architecture and requirement traceability of the integrated monitoring system. Developed with System Composer (17)

Readiness Level (TRL), there's an expectation for expedited loading-unloading and train composition times. This is addressed through an autonomous guidance system in terminals, enabling wagon communication with the infrastructure control room and among themselves. To implement all the above-mentioned points, electricity is required along the entire trainset to power the sensors and control units of each subsystem.

## 4.2 Functional Model

The subsequent phase involves translating the high-level requirement list into a detailed functional layout, depicted in Fig. 1.

Requirement	Monitor_Bogie	Monitor_Cargo	Sense_Environment	Computing	SendWarning
R1 Monitorability TSI 2014	+	+			
R2 Module moves automatically in freight terminals			+		
R2.1 Module detects object or events			+		
R2.1.1 If anything is detected stop			+		
R2.2 Mission following					
R2.2.1 Max speed limit					
R2.3 Fall Safe ATO					
R3 Safety and Security	+				
R3.1 Thermal control of the load					
R3.1.2 Read temperature from the container					
R3.1.1 Ensure power continuously to the container					
R3.2 Load positioning					
R3.3 Load integrity					
R3.4 anti-lock					
R3.5 anti-slip & anti-skid					
R3.5.1 sanding capability					
R3.6 Fallsafe response					
R4 Maintainability and availability					
R4.1 Motor state of health					
R4.2 Gearbox state of health					
R4.3 Bogie state of health					
R4.4 Explainability					
R4.5 Predictive maintenance					
R5 Power along the convey					

Figure 2: Traceability of requirement and needs into the functional architecture Developed with System Composer (17)

The system’s definition begins with delineating its boundaries: the core function is ”monitoring.” Consequently, inputs include data from the environment—comprising the train and its surroundings—and energy to facilitate actions. Outputs consist of warnings and, if necessary, train controls.

Next, considering the requirements and needs, the system is segmented into three sequential components. The first component involves ”monitoring” the bogie, load, and external environment. The second component entails ”storing” the data received from these systems and ”computing” it for analysis, leading to the third component, which is ”sending” a warning if any signal deviates from expected results. Each function was further decomposed into sub-functions until it was intuitive to derive behavioural components for the logical architecture. Each identified function is correlated with a requirement or need, with traceability detailed in Fig. 2.

### 4.3 Logical architecture

The logical architecture of the integrated monitoring platform is created as follows: for each function, a specific sub-system is designed, as shown in Tab. 1.

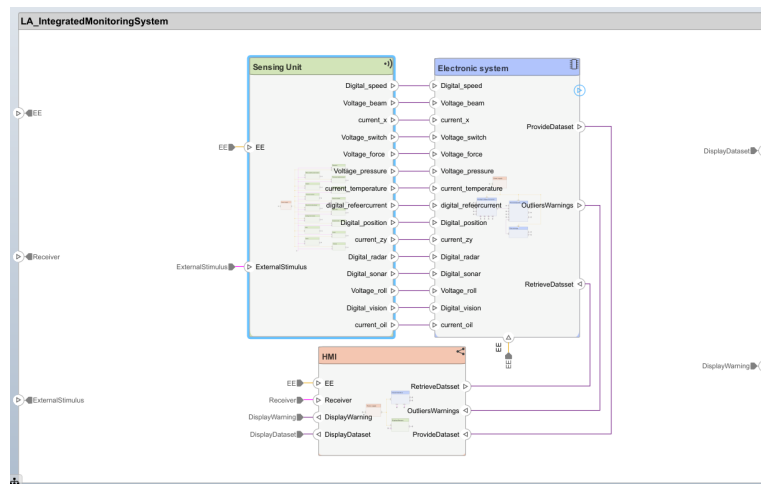

Figure 3: Logic Architecture and Stereotypes allocation of the integrated monitoring system. Developed with System Composer (17)

The final result of the logical architecture is shown in Fig. 3, where it is possible to find the behavioural components of the system. It consists of a sensing unit, an elec-

Table 1: List of logic sub-systems to be implemented

Component location	Function	Subsystem	Acronym
<b>Bogie</b>	<i>Axlebox Temperature monitoring</i>	Hot Axlebox Detection	<i>HABS</i>
	<i>Detect Excessive Bogie Hunting (as in TSI) and Lateral and Vertical bogie dynamics</i>	Yaw Detection System	<i>YDS and ACCYZ</i>
	<i>Detect if motor is not working as expected</i>	Traction Motor Temperature	<i>TMT</i>
	<i>Monitor Lubricant Status</i>	Gearbox Monitoring	<i>GBM</i>
<b>Braking System</b>	<i>Monitor braking phases</i>	Brake Plant Status	<i>BPS</i>
<b>Wagon</b>	<i>Monitor Wagon Roll</i>	Attitude Monitoring System	<i>AMS</i>
<b>Cargo</b>	<i>Check that the cargo is correctly secured and in place</i>	Payload Positioning	<i>PP</i>

	LA	Integrated Monitoring System	HMI	Visual Interface	Keyboard/Joystick	Power supply	Sensing Unit	Motion-said Accelerometer	Pressure sensor	Amplifier	GPS	Radar	Sonar	Camera	Switch	Odometer	Thermal optical sensor	Force sensor	Power supply	Cyclopede	Thermoelectric	Analog level sensor	Biaxial Accelerometer	Electronic system	Power supply	Analog to digital converter	Processing Unit	Data storage
[-] R1 Monitorability TSI 2014																												
[-] R2 Module moves automatically in freight terminals																												
[-] R2.1 Module detects object or events																												
[-] R2.1.1 If anything is detected stop																												
[-] R2.2 Mission following																												
[-] R2.2.1 Max speed km/h																												
[-] R2.3 Fail Safe ATO																												
[-] R3 Safety and Security																												
[-] R3.1 Thermal control of the load																												
[-] R3.1.2 Read temperature from the container																												
[-] R3.1.1 Ensure power continuously to the container																												
[-] R3.2 Load positioning																												
[-] R3.3 Load integrity																												
[-] R3.4 anti-lock																												
[-] R3.5 anti-slip & anti-skid																												
[-] R3.5.1 sanding capability																												
[-] R3.6 Failsafe response																												
[-] R4 Maintainability and availability																												
[-] R4.1 Motor state of health																												
[-] R4.2 Gearbox state of health																												
[-] R4.3 Bogie state of health																												
[-] R4.4 Explainability																												
[-] R4.5 Predictive maintenance																												
[-] R5 Power along the convey																												

Figure 4: Traceability of requirement and needs into the functional architecture. Developed with System Composer (17)

tronic system that processes and stores data, and a *Human Machine Interface* (HMI). Each of these is further divided into smaller components, e.g. the HMI includes a power supply unit, a visual aid, and a keyboard or mouse-type interface for interaction between the receiver (typically a human) and the system.

In this case, both the components and their interconnections reflect reality more closely: for example, from "gearbox data" to "current\_oil" and "current\_temperature", namely the current signals coming from the analog oil level measurement sensor and the thermostat that measures oil temperature.

Each sub-system interfaces with the monitoring boards, connected via appropriate wiring from the central unit—one per vehicle for both P2F-EMU and F-EMU—to the terminal units positioned near each system to be monitored, as indicated by the functional diagram. These terminal units encompass various sensors, and the monitoring system collects data from them and provides power.

Furthermore, all the functions are allocated to the behavioural components of the logical architecture. Because of these relationships the requirements and needs that were met by the functions are also met in this architecture, as can be seen in Fig. 4.

#### 4.4 Physical model

The translation of the logical model into a physical model involves selecting the actual components constituting the system. For the BME, a modular architecture is proposed, utilizing multiple boards to accommodate various sensor types. This design ensures system flexibility: boards can be easily swapped in case of failure, and inputs can be

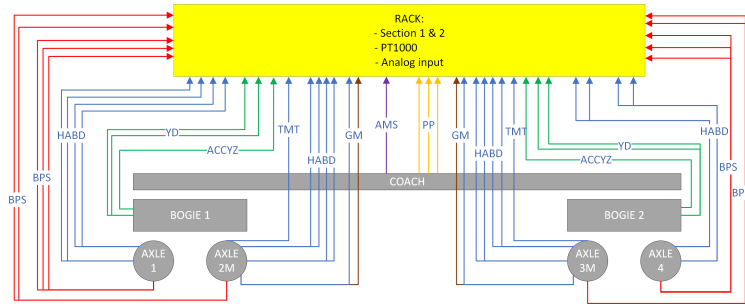

Figure 5: BMS wiring layout on P2F-EMU

quickly reconfigured if the number of sensors changes. Each BMS also necessitates a dedicated power supply management board, typically operating at low DC voltage (3 – 32V), which can be regulated using a PWM unit. Sensor boards gather their outputs and transmit them to the processing board, where software is executed to read and process data into reports or forward them to the storage unit. Complete physical models, including function and sensor descriptions, are summarized in Table 2.

Sensor characteristics are taken by official manufacturer data sheets, whose name is not reported. The final physical architecture for the F-EMU is shown in Figure 5.

The mentioned TSI regulation is currently enforced on HS trainsets, which already incorporate such equipment onboard, fulfilling this requirement for P2F-EMU architectures. Regarding the F-EMU, although not explicitly covered by the TSI, an on-board system detecting both bearing temperature and bogie hunting is implemented. This serves multiple purposes, including operation on secondary lines lacking suitable trackside systems and gathering information on key components' health, such as bearings and bogies. Despite lower speeds, the F-EMU bears higher loads, warranting continuous component monitoring to enhance safety. Notably, brake cylinders play a pivotal role in diagnostics, enabling the detection of system damage and ensuring proper braking manoeuvres. This system facilitates fault detection and predictive maintenance by accumulating diagnostic data.

Table 2: Detail of sensors and functions

Function	Description	Sensor Chosen
<i>HABD</i>	<i>Axlebox temperature monitoring</i>	PT 1000 sensor: 24 Vdc, current output
<i>YDS</i>	<i>X-axis acceleration monitoring</i>	mono-axial accelerometer: 24 Vdc, current output
<i>GMB</i>	<i>Oil level monitoring</i>	analog level sensor: 12 Vdc, current output
	<i>Oil temperature monitoring</i>	PT1000 sensor: 12 Vdc, current output
<i>ACCYZ</i>	<i>Y and Z axis accelerations monitoring</i>	bi-axial accelerometer: 24 Vdc, current output
<i>TMT</i>	<i>Stator winding temperature monitoring</i>	PT1000 sensor: 24 Vdc, current output
<i>BPS</i>	<i>Brake cylinder pressure monitoring</i>	Pressure sensor: 3.3 Vdc, voltage output
<i>AMS</i>	<i>Wagon roll monitoring</i>	Mono-axial gyroscope: 14 Vdc, voltage output
<i>PP(F-EMU)</i>	<i>Twist-lock and trailer turntable secure</i>	Roller microswitch: 4 Vdc
<i>PP(P2F-EMU)</i>	<i>Goods in position</i>	Thru-beam optical sensor: 24 Vdc Force sensor: 5 Vdc, voltage output

For motorized wagons, differing in architecture between P2F-EMU and F-EMU, data collection encompasses gearbox health and traction motor performance. Regarding gearboxes, monitoring oil temperature enables early detection of potential damage or deviations in optimal lubricant operating conditions, allowing preventive intervention. Real-time monitoring of oil quantity facilitates efficient refilling scheduling. Regarding traction motors, the focus is on verifying expected electrical capacity and preempting electrical or structural damage.

In addition to monitoring component health, the wagon's dynamics are observed to detect potential tipping risks associated with abnormal running dynamics stemming from bogie-level structural damage, external impacts, or load imbalances. Monitoring includes ensuring proper load positioning for both intermodal and groupage cargo. A two-section physical layout ensures sensor symmetry across bogies, with a separate board for coach-related sensors, incorporating redundancies for reliability.

Furthermore, to achieve a unified interface for all functions within a single train interface, such as the TCMS, all monitoring subsystems must be interconnected and capable of communicating with each other to transmit data. This data can be relayed to the cockpit for real-time assessment and immediate corrective actions by the driver, as well as to memory units for later downloading and processing. These memory units serve as a storage, either on the train or in the cloud, for a database used for planning both *Condition Based Maintenance* (CBM) and predictive maintenance operations.

## 5 Discussion

The presented framework aims to fulfil the functions of monitoring aspects of both key components of the convoy, including safety aspects, and the status of the payload. To this end, it is necessary to correctly manage the information collected, whether it is warning or danger signals, for which a corrective action or emergency manoeuvre must be taken promptly; or events being recorded for maintenance purposes.

Therefore, a three-level detection system of the events is developed:

- storage event: data acquisition to store parameters of the operation.
- warning event: automatic acquisition of all running parameters if a sensor detects abnormal values. This event corresponds to the detection of a certain parameter out of the expected ranges for that component.
- alarm event: its operating principle is like a warning event, but is of greater severity and may include structural damage or safety aspects.

Threshold values are scripted in the software code, and are editable with special manoeuvres (e.g. a dedicated terminal operated during maintenance), and can therefore be customised as required, making the architecture even more flexible.

For each of the above levels, BMS can trigger actions, as shown in Table 3. For storage events, the data acquisition occurs on a periodic event governed by the TCMS, such as a time or kilometre recurrence, or a braking or traction command, and the BMS will send the data set to the storage unit or a ground receiver. In the case of a

warning, a signal is sent to the display of the TCMS in the cab, and a yellow lamp lights up: the driver is then left free to investigate the signal. This event is recorded so that it can be analysed later together with the rest of the data. In the case of an alarm, the procedure is similar to that of the warning, but with a red light and handing over the control to the TCMS, since a prompt action must be taken, given the seriousness of the event and the compromise of safety aspects. Such an action might be an emergency braking, or a speed limitation, as well as the exclusion of a traction motor, etc.

Table 3: Three-level event detection system

<i>Level</i>	<i>Detection</i>	<i>Action</i>
0	TCMS event	data acquisition & storage
1	value beyond lower threshold	yellow lamp & storage
2	value beyond critical threshold	red lamp, storage & TCMS takeover

## 6 Conclusion

This paper proposes an integrated monitoring system for a next-generation freight electric multiple-unit, developed using MBSE techniques. This subsystem enables the monitoring of both freight and rolling stock, a requirement for compatibility with Italian HS lines managed by RFI. The implementation of a monitoring system for freight trains is crucial for the advancement of these vehicles, serving as a fundamental factor in attracting demand to rail transport, which currently lacks security and reliability. The Reliability, Availability, Maintainability, and Safety (RAMS) aspects of rail freight would significantly benefit from such an integrated system, offering customers the ability to track and control the goods being transported, among other features.

Currently, freight trains are being retrofitted with self-powered sensors to address these concerns. While the applications explored thus far are beneficial, they are only considered temporary solutions. The DAC marks an initial milestone in this regard by enabling the flow of electricity necessary to power the sensors throughout the convoy. In contrast, the F-EMU represents a complete revolution in the concept of freight trains, with the system designed here specifically tailored to the subsystems mounted on the multiple-unit train in question. The presented system is still undergoing validation, with ongoing studies aimed at demonstrating that the sensors will effectively trigger the appropriate alarms and signals to the TCMS and the cockpit.

The F-EMU holds the potential to break through the stagnation that characterizes contemporary freight transport. In alignment with European Union directives aimed at reducing the environmental footprint of logistics chains, there's a growing imperative to shift goods from road to rail. To facilitate this transition, the transport supply must align with market demands. The integrated monitoring system serves as a vital subsystem of the train, addressing some of these demands by enhancing the safety, reliability, and security of rail transport.

## References

- [1] “Technical specifications for interoperability,” pp. 33–34, 2014. ERA, European Union Agency for Railways.
- [2] “30 by 2030 rail freight strategy to boost modal shift,” *Rail Freight Forward*, 2020.
- [3] A. Mandelli, “Smart train,” *Tecnica Professionale*, vol. 4, pp. 10–11, 2022.
- [4] F. Zanelli, M. Mauri, F. Castelli-Dezza, E. Sabbioni, D. Tarsitano, and N. Debatisti, “Energy autonomous wireless sensor nodes for freight train braking systems monitoring,” *Sensors*, vol. 22, no. 5, 2022.
- [5] F. Zanelli, A. Sabbioni, M. Carnevale, M. Mauri, D. Tarsitano, F. Castelli-Dezza, and N. Debatisti, “Wireless sensor nodes for freight trains condition monitoring based on geo-localized vibration measurements,” *Proceedings of the Institution of Mechanical Engineers, Part F: Journal of Rail and Rapid Transit*.
- [6] Q. Wang, T. Gao, H. Tang, Y. Wang, Z. Chen, J. Wang, P. Wang, and Q. He, “A feature engineering framework for online fault diagnosis of freight train air brakes,” *ScienceDirect*, vol. 182, p. 109672, 2021.
- [7] Q. Wang, T. Gao, H. Tang, Y. Wang, Z. Chen, J. Wang, P. Wang, and Q. He, “Platform of attitude monitoring for freight high speed trains,” *Journal of Physics: Conference Series*, 2021.
- [8] M. Corfiati, B. Dalla Chiara, and M. Galfré, “Evolution lines in the maintenance of rolling stock,” *Ingegneria Ferroviaria*, vol. 9, pp. 751–772, 2011.
- [9] T. May, “Hitachi rail is installing a world-first live monitoring system on great western railway’s (gwr) high-speed fleet to provide digital data on train wheelset performance,” *Railway News*, 2022.
- [10] W. H. Sneed and R. L. Smith, “On-board real-time railroad bearing defect detection and monitoring,” in *Proceedings of the 1998 ASME/IEEE joint railroad conference*, pp. 149–153, IEEE, 1998.
- [11] N. Bosso, A. Gugliotta, M. Magelli, and N. Zampieri, “Monitoring of railway freight vehicles using onboard systems,” *Procedia Structural Integrity*, vol. 24, pp. 692–705, 2019.
- [12] C. Li, S. Luo, C. Cole, and M. Spiriyagin, “An overview: modern techniques for railway vehicle on-board health monitoring systems,” *Vehicle system dynamics*, vol. 55, no. 7, pp. 1045–1070, 2017.
- [13] N. Bosso, A. Gugliotta, M. Magelli, and N. Zampieri, “Monitoring of railway freight vehicles using onboard systems,” *Procedia Structural Integrity*, vol. 24, pp. 692–705, 2019. AIAS 2019 International Conference on Stress Analysis.

- [14] B. Dalla Chiara, “Distributed-power freight train,” *Ingegneria Ferroviaria*, vol. 4, pp. 257–287, 2021.
- [15] S. Gurri, M. Bocchieri, D. Galasso, V. Operti, and B. Dalla Chiara, “Assessing the speed of an electric multiple-unit freight train on high-speed lines,” *Ingegneria Ferroviaria*, 2023.
- [16] R. Adcock (EIC) and N. Hoboken, *The Guide to the Systems Engineering Body of Knowledge (SEBoK)*. 2014.
- [17] MATLAB, *version R2022b*. Natick, Massachusetts: The MathWorks Inc., 2022.
- [18] T. Weilkiens, *Systems engineering with SysML/UML: modeling, analysis, design*. Elsevier, 2011.