

Reducing Ground Impact Hazards of a Solar UAV Through Modelling and Analysis

Original

Reducing Ground Impact Hazards of a Solar UAV Through Modelling and Analysis / Dalla Vedova, M. D. L.; D'Amico, F. A.; De Maria, T.; Maggiore, P.; Pitarresi, G.. - In: JOURNAL OF PHYSICS. CONFERENCE SERIES. - ISSN 1742-6588. - ELETTRONICO. - 2716:(2024). (Intervento presentato al convegno 13th EASN International Conference on Innovation in Aviation and Space for Opening New Horizons tenutosi a Salerno (ITA) nel 2023) [10.1088/1742-6596/2716/1/012065].

Availability:

This version is available at: 11583/2991500 since: 2024-08-05T14:48:16Z

Publisher:

Institute of Physics

Published

DOI:10.1088/1742-6596/2716/1/012065

Terms of use:

This article is made available under terms and conditions as specified in the corresponding bibliographic description in the repository

Publisher copyright

(Article begins on next page)

PAPER • OPEN ACCESS

Reducing Ground Impact Hazards of a Solar UAV Through Modelling and Analysis

To cite this article: M D L Dalla Vedova *et al* 2024 *J. Phys.: Conf. Ser.* **2716** 012065

View the [article online](#) for updates and enhancements.

You may also like

- [Dynamic modeling of shaping-changing cross parachute](#)
Chunhui Wang, Hongmiao Zhou and Jianqiao Yu
- [An infinitely differentiable model for deploying parachutes](#)
H Rodrigues, A L Soares, A C dos Santos et al.
- [Supporting mechanism design of parachutes for 2.4m×2.4m transonic wind tunnel in CARDC](#)
Dong Hao, Lin Zhang, Jing Yu et al.

PRIME
PACIFIC RIM MEETING
ON ELECTROCHEMICAL
AND SOLID STATE SCIENCE

HONOLULU, HI
October 6-11, 2024

Joint International Meeting of
The Electrochemical Society of Japan (ECSJ)
The Korean Electrochemical Society (KECS)
The Electrochemical Society (ECS)

Early Registration Deadline:
September 3, 2024

**MAKE YOUR PLANS
NOW!**

Reducing Ground Impact Hazards of a Solar UAV Through Modelling and Analysis

M D L Dalla Vedova¹, F A D'Amico², T De Maria¹, P Maggiore¹ and G Pitarresi¹

¹ Department of Mechanics and Aerospace Engineering, Politecnico di Torino, Italy

² Engineering, Leonardo Divisione Velivoli, Torino, Italy

E-mail: matteo.dallavedova@polito.it

Abstract. The research described was conducted by a student team dedicated to finding sustainable and long-endurance systems and outlines an innovative solar panel UAV aircraft solution. Our prototype demonstrated the feasibility of the concept, while the second aircraft, currently in the design phase, aims to improve performance further and allow for extended self-powered flight time. The sustainable approach of our project addresses the growing need to reduce the environmental impact of transportation technologies. The main objective of this study is to address the requirements of the Specific Category - Civil Drones regulation, promulgated by EASA, regarding the risk associated with the impact of the aircraft on the ground in case of an in-flight failure. To address this issue, we conducted an in-depth analysis of possible failure scenarios and their consequences on the safety of the aircraft and people on the ground. Furthermore, the team developed models for risk assessment to evaluate the risk associated with solar panel UAV operation. To mitigate the risk of impact, we considered using a parachute, the effectiveness of which was analysed using a dynamic model implemented in Simulink. The analysis allowed us to evaluate the semi-controlled descent of the aircraft with the parachute attached, providing valuable information to optimize the safety system further. In conclusion, our study significantly contributes to ensuring the safety of our model in flight and on the ground through ground-impact risk management while promoting the development of sustainable and innovative solutions in the aviation field.

List of Abbreviations

EASA	European Union Aviation Safety Agency
RA	Record Aircraft
UAV	Unmanned Aerial Vehicle
UAS	Unmanned Aircraft System
EAR	Easy Access Rules
SORA	Specific Operation Risk Assessment
ConOps	Concept of Operation
GRC	Ground Risk Class
ARC	Air Risk Class
SAIL	Specific Assurance and Integrity Level
VLOS	Visual Line Of Sight
OSO	Operational Safety Objectives
ISA	International Standard Atmosphere



1. Introduction

In the following, the project developed in the context of a student team is described focusing on the requirements set forth in European Commission Implementing Regulation 2019/947 of the European Commission. The scope of this Regulation is to standardize the rules and procedures for the operation of unmanned aircraft. In the Regulation, not only the rules and procedures for the operations of unmanned aircraft are presented, but also the provisions for the personnel, including remote pilots and organizations involved in those operations.

1.1. Project Introduction

The Record Aircraft (RA) project (Figure 1), within the team Icarus of the Politecnico di Torino, aims to design and build a solar-powered Unmanned Aircraft System (UAS) whose main challenge is to achieve self-sustaining energy during daylight flight hours. An Unmanned Aircraft System means – as defined in the regulation – an unmanned aircraft and the equipment to control it remotely.

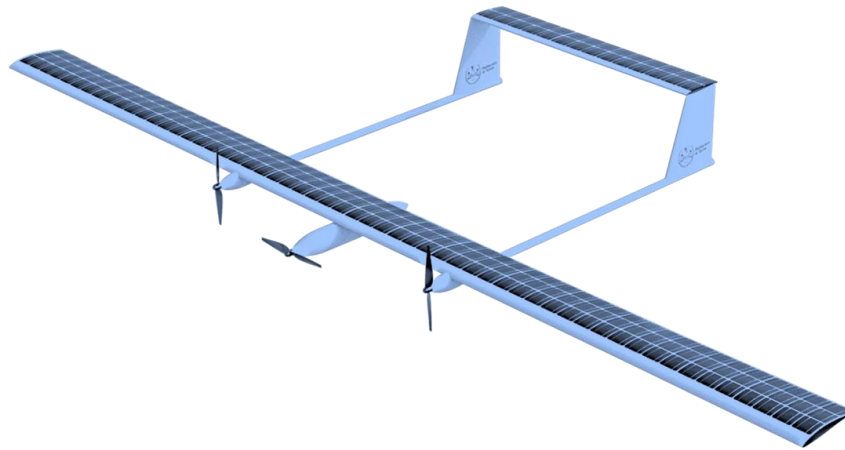

Figure 1. Schematic of the UAV developed by the Icarus team for the Record Aircraft (RA) project.

2. Certification Workflow

The requirements set forth in the European Commission Implementing Regulation 2019/947 define the rules for all the operations concerning unmanned aircraft [1]. At first, the Regulation foresees the category of the operation that the unmanned aircraft should perform (Article 3).

Our mission, for the dimensional characteristics of the UAV, falls into the “specific” category. The “specific” category requires an operational authorisation issued by the competent Authority pursuant to Article 12. To obtain the operational authorisation, the applicant shall prepare and submit to the Authority an operational risk assessment which must contain information like characteristics of the UAS operation, a range of possible risk mitigation measures etc.

The regulation 2019/947 describes in Article 11 all the rules for conducting an operational risk assessment. However, the regulation sets forth general requirements and contents of the operational risk assessment but does not give a procedure on how to develop the operational risk assessment from the applicant perspective. To implement the requirements of Article 11 – as per all the general requirements set forth by the regulation 2019/947 – the European Aviation Safety Agency (EASA) issued the “Easy Access Rules (EAR) for Unmanned Aircraft Systems” with the aim to combine all the Acceptable Means of Compliance and Guidance Material as well as the EU regulations.

In the Guidance Material for Article 11, EASA presented various acceptable means of compliance that can be used by the applicant for the preparation of the operational risk assessment. After an evaluation of all the methodologies proposed applicable to the UAS in consideration, only the Specific Operations Risk Assessment (SORA) developed by JARUS resulted valuable for our project [2].

3. Specific Operation Risk Assessment – Workflow

For its definition, the SORA provides a methodology to guide both the competent Authority and the UAS operator in determining whether the UAS operation can be conducted in a safe manner. The SORA workflow presented by JARUS guide the UAS operator step by step beginning by the Concept of Operations description concluding with the comprehensive safety portfolio. Before applying the SORA, the applicant should obviously verify that the proposed operation is feasible, it does not fall into the “open” or “certified” category and shall verify that the operation is not covered by a “standard scenario” or a Predefined Risk Assessment (PDRA). The Concept of Operations (ConOps) description is the most crucial part of the entire SORA workflow because is the foundation of all the other activities, it should be as detailed and accurate as possible. It should also include information like the manners of interaction with the Air Navigation Service Provider (ANSP)/Competent Authority. The ConOps shall take into account all the other steps, mitigations and Operational Safety Objectives (OSOs) for this reason, it is considered an iterative process. Before going on with the ConOps description applied to our case – which for brevity is the only step of the SORA process deepened – it is meaningful to present the workflow of the SORA and describe in couple words all the steps. In the following, for brevity, only the main considerations concerning each step are presented.

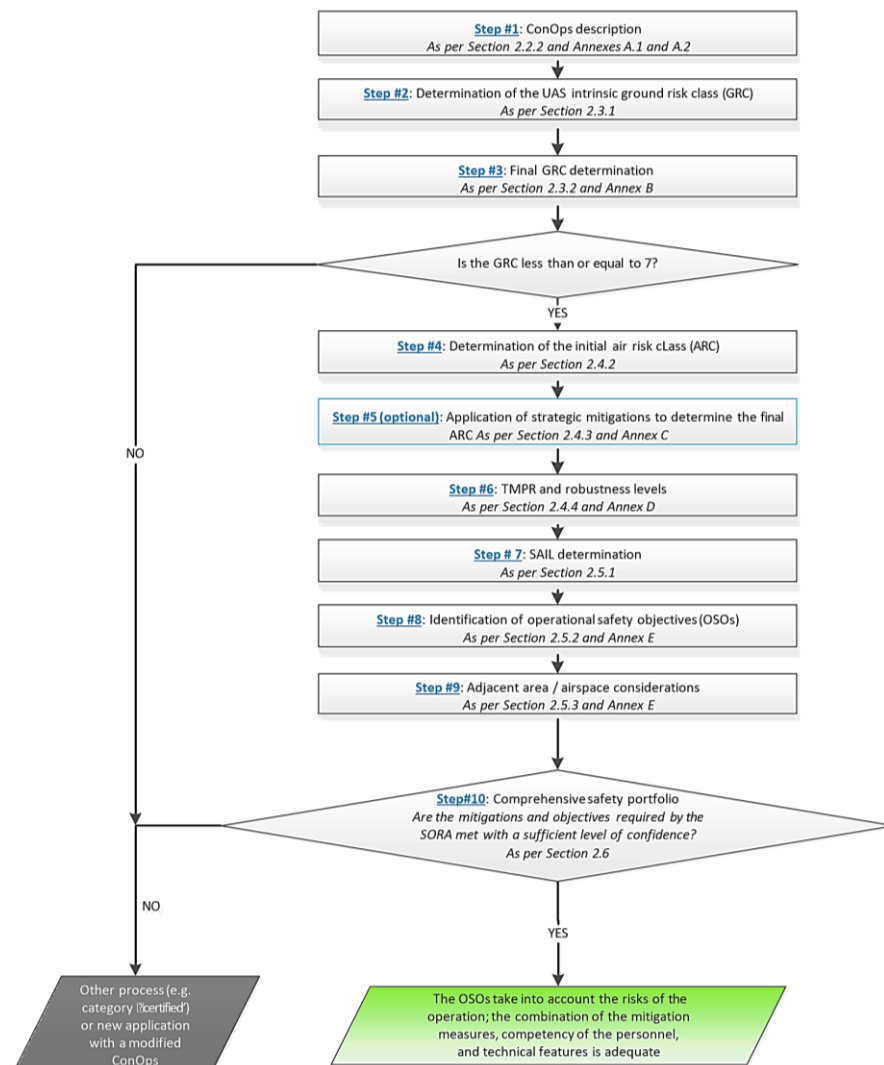

Figure 2. The workflow above reported summarizes the steps needed for the SORA.

- **ConOps description:** The main characteristics concerning the organization, the aircraft performances as well as the responsibilities and operations are described here.
- **Ground Risk Class (GRC):** The Ground Risk Class relates to the risk of a person being struck by the UAS. Here, the operational scenario shall be considered to determine this value as well as the mitigations used by the applicant to reduce the intrinsic Ground Risk Class to a smaller value, in particular, to increase the robustness of the mitigation “M2 – Effects of ground impact”, additional considerations have been done and later presented.
- **Air Risk Class (ARC):** As for the GRC, the ARC relates to the risk of mid-air collision. The aim of the ARC is to determine – basing on the operational airspace described in the ConOps and the tactical mitigations considered – the rate at which a UAS would encounter a manned aircraft in typical generalised civil airspace.
- **Specific Assurance and Integrity Level (SAIL):** Given the final value of the GRC as a consequence of the mitigations applied and given the final value of the ARC as a consequence of the tactical mitigations – whether “see and avoid” for VLOS operations or “detect and avoid” – the SAIL parameter can be calculated. The SAIL value combines the risk associated to the ground impact and mid-air impact. This value is crucial because defines the OSOs to be compliant with and the description of the activities that might support the compliance with those objectives.
- **Operational Safety Objectives (OSOs):** The last step of the process is to use the SAIL level to evaluate the defences within the operation in the form of OSOs and the associated level of robustness.

3.1. Mitigation M2 to reduce the GRC

The GRC determined in the step #2 shall be subjected to additional considerations before being considered as final. While evaluating the Mitigation M2, to furtherly ensure a “medium robustness” given by the usage of a parachute system, it has been developed a simulator of its activation in case of failure. With this simulator, the kinetic energy on the ground has been calculated with and without the parachute to show its performance and assure its effectivity.

4. Failure and Parachute Activation Simulation

4.1. Hypothesis

A number of assumptions have been made in the physical modelling of the system. The following key assumptions have been made based on a reasoned approach that does not introduce significant approximations that deviate the model from the actual phenomenon. Equations implemented in the model are an approximation of those described in Guglieri [7], which describes the motion of a payload attached to a parachute smaller than ours. It is not ruled out that in future developments of the project some of these assumptions may be revised to improve the approximation and make the Simulink model more closely resemble the real event. The ultimate goal of the model is to provide data on the fall speed, both vertical and horizontal, to evaluate the kinetic energy the aircraft possesses upon impact.

1. The simulation was performed considering the problem in two dimensions, completely ignoring all phenomena occurring along the body y-axis positioned along the wingspan. The axes reported in the results are inertial axes with the z-axis perpendicular to the ground and the x-axis in the horizontal direction of the aircraft's motion.
2. No wind consideration was taken into account.
3. All movable surfaces do not contribute to the force exerted on the aircraft, thus we assume that the malfunction occurs when the aircraft is cruising or, if the malfunction occurs while in manoeuvre, the aircraft is positioned in cruising conditions before deploying the parachute. This control system, although not modelled, is plausible as there are 15 seconds from engine shutdown to parachute deployment.
4. Density data in relation to altitude were obtained from the standard ISA atmosphere, even though we know that the density does not change much in 250 m (about a 2% variation).

5. The cable connecting the parachute to the aircraft is rigid, so the two are modelled as two bodies moving rigidly connected by this cable, which instantly moves the parachute to a certain distance and opens within a certain time.
6. A consequence of point 3 is that the aircraft flies at a constant attitude, with a cruising incidence of about 3° (approximate), and all aerodynamic force coefficients C_D, C_L, C_Z were evaluated using VSP software (developed by NASA). This is not entirely correct because we assume that the aircraft lands perpendicularly to the ground without any oscillation on the y-axis, so it is a rigid body, and the only thing moving is the parachute pivoting on the aircraft. On the one hand, this is not ideal because changes in attitude do occur and these necessarily cause a variation in the force coefficients, so ideally the polar should be inserted and these coefficients evaluated based on the angle of attitude. On the other hand, the error is not too significant because the parachute simply slows down the horizontal speed very quickly, so the contributions of Resistance in the x direction and Lift almost immediately cancel out. The assumption of a constant C_Z is as if the aircraft fell like a flat body.
7. All the parameters input into the model, such as mass, wing surface area, etc., are based on actual data derived from an existing project that has already been designed and built by the ICARUS team.

4.2. Parachute simulation Consideration

Prior to simulating aircraft deceleration using a parachute, a few observations about the parachute configuration need to be considered. The parachute is essential for reducing the force of impact that could be hazardous due to the weight of the aircraft and the size of the wing surface needed for energy production. We chose a commercially available parachute because the manufacturer has already tested it for reliability. We have chosen a parachute made by Manta-Air [3], which is certified to ISO 9001:2015 and supplies its products to various businesses, such as Elbit System, Alpha Unmanned Systems, IAI, and others. The following table displays the data for the selected parachute.

Diameter	2.7	[m]
Area	5.72	[m²]
Mass	0.210	[Kg]
Max Load	39	[Kg]
w	5.1	[m/s]
Length suspension line	3.050	[m]

The fuselage will integrate the launcher tube for the parachute, which will be linked to the flight control system. The launcher will receive a PWM input signal, which will trigger a spring to deploy the parachute and enable inflation. The parachute is connected to the aircraft's structure to distribute the load uniformly and minimise undue stress on the structure. The parachute model supposes two degrees of freedom and assumes a rigid connection between it and the payload. During inflation and deployment, parachute canopy and the air have dynamic interactions that generate forces affecting both the parachute and the surrounding fluid. The mass addition improves the modelling of parachute behaviour and fall.

$$m_a = k_a \cdot \frac{4}{3} \cdot \pi \cdot \rho \cdot r^3$$

Various values of k_a were estimated [4][5]. In this study, we utilized Heinrich's estimation, which sets the value of k_a at 0.92. The parachute opening process can be divided into two stages: deployment and inflation. Deployment is the primary step when the parachute gets released from its launcher and begins to unfold. We cannot take the parachute pilot forces into account since we can consider the parachute ejection stage as instantaneous through an expulsion spring. The inflation process takes place once the parachute is deployed, where air fills the canopy, causing it to expand and create drag to reduce the descent speed. The canopy model used in this study is based on specific assumptions.

The model assumes that the canopy remains aligned with the velocity vector in the simulation without accounting for the parachute's lift and moment coefficients. Furthermore, the model assumes that the added mass of the parachute remains constant during both inflation and operation. The model maintains a conservative constant added mass based on the fully inflated parachute value while gradually increasing the drag area value as the parachute inflates. This feature of the model enables the simulation of the inflation process. The inflation is modelled by gradually increasing the drag area value ($C_D \cdot S$), which is the product of the drag coefficient (C_D) and the projected area (S), from 0% to 100% over a specific time (t_f) [6].

$$t_f = \frac{8 \cdot D_0}{V_s^{0.9}}$$

Where D_0 is the nominal parachute diameter and V_s is the velocity at line stretch.

4.3. Simulation Model

Simulating model for UAV recovery was developed using Matlab/Simulink software, including ISA Atmosphere Subsystems, Motion Equation Subsystem, parachute Subsystem, and UAV Subsystem. An accurate simulation is necessary to comply with SORA methodology, ensuring a smooth descent process.

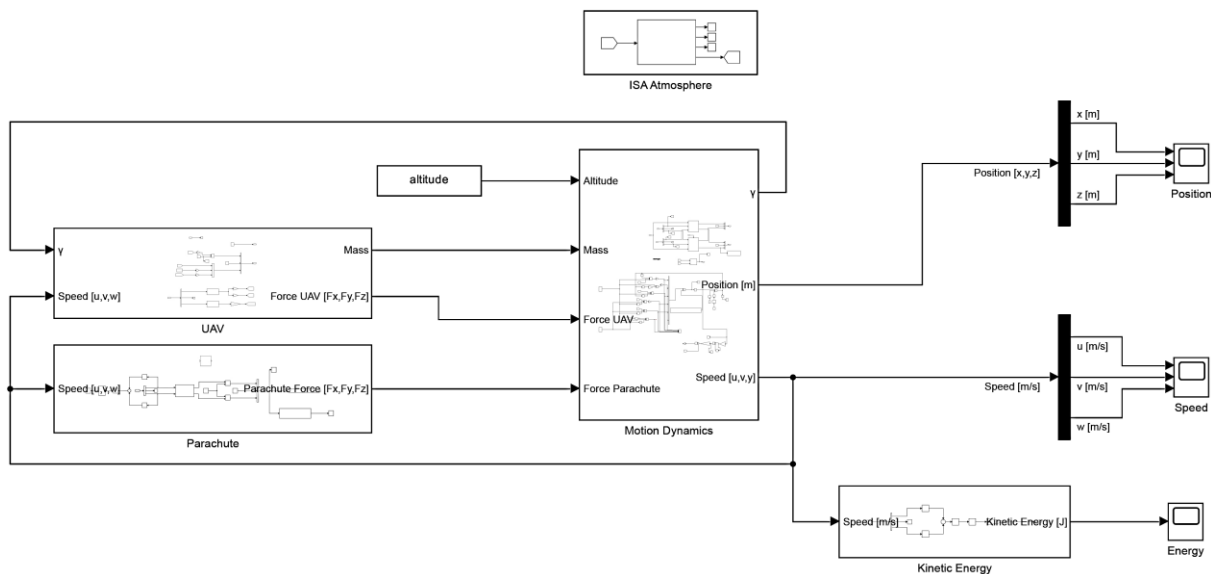

Figure 3. Schematic of the proposed UAV simulating model.

4.4. Simulation Result

In the final section of this paper, we shall delve into an analysis of the most salient quantities derived from our simulations, comparing them to scenarios in which the selected parachute is not integrated.

1. Initially, we assess the force exerted on the parachute. As illustrated in Figure 4, the timespan from the parachute's deployment can be evaluated. The transient response indicates that a peak occurs post-deployment due to the parachute's longitudinal direction, which nearly halts the longitudinal velocity of the aircraft. As the parachute aligns vertically, the transient exhausts, and the force countering the weight force, now perpendicular to the aircraft, settles at a steady-state value. With results comparable to those described in Panta et al. [8]
2. The second graph, Figure 5, illustrates the trajectory of the rigid body formed by the UAV and parachute in space. As mentioned, a two-dimensional simulation was carried out, with time represented as the third axis on the graph. We can observe that within 45 seconds of deployment, the aircraft reaches the ground.

3. The third graph, presented in Figure 6, presents the UAV's horizontal and vertical velocities compared to a scenario without a parachute. It is evident that without a parachute, the descent speed is significantly higher, and the horizontal speed does not decrease. This results in a higher impact energy upon crashing into the ground. With the parachute, the horizontal speed is almost null, as it is immediately reduced once the parachute opens in the direction of the cruising speed, and the vertical speed remains at a relatively constant value of approximately 5 m/s, as expected from the parachute's datasheet.
4. Finally, Figure 7 displays the kinetic energy values derived from $E = \frac{1}{2} m_{tot} (\vec{V}^2)$, compared with the value that would be obtained if the parachute were not deployed. It is noticeable that due to the high fall speed (and also horizontal speed), the value is significantly high, and the crash into the ground occurs in significantly less time, about 25 seconds (About half the time it takes if you use the parachute), considering an initial altitude of 250 meters. The drastic reduction in descent speed and consequently energy caused by the parachute's deployment highlights the essentiality of integrating a parachute into an aircraft of this size to mitigate the risks associated with a catastrophic fall due to loss of control and subsequent aircraft crash.

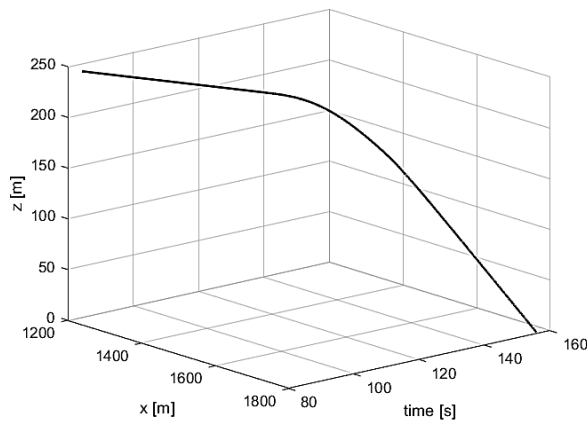

Figure 4. Trajectory.

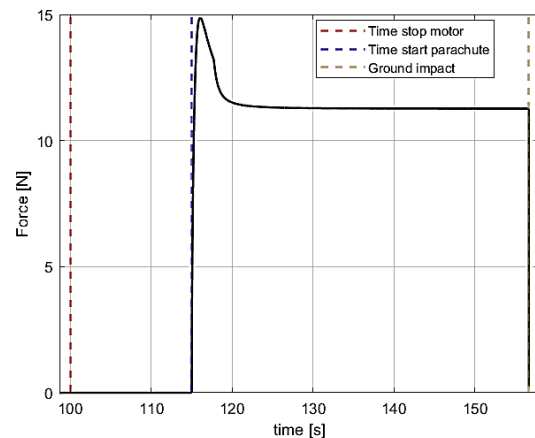

Figure 5. Force on Parachute

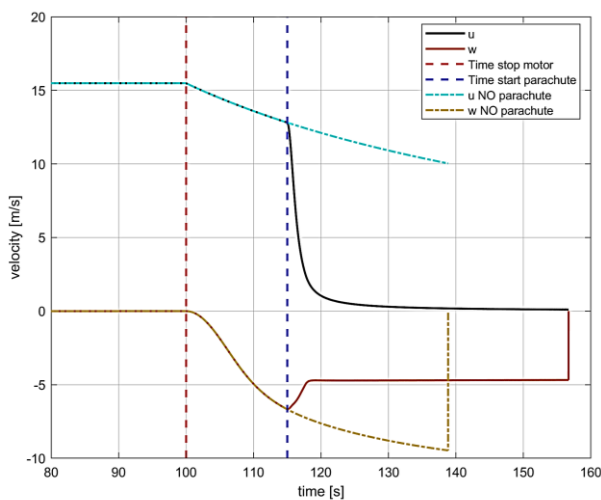

Figure 6: Speed Comparison

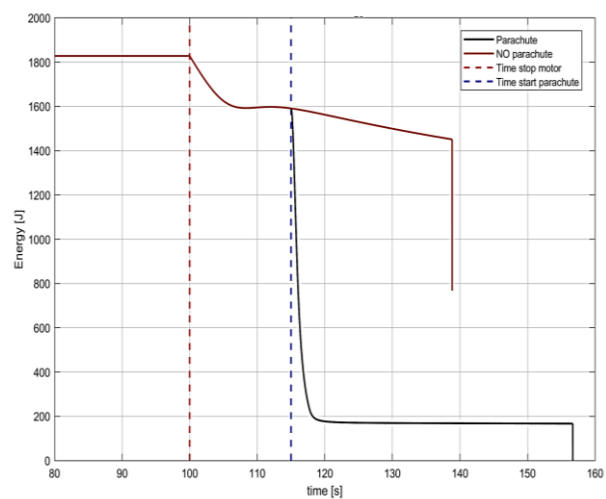

Figure 7: Kinetics comparison

However, the model used should be regarded as an initial version, and it is planned to refine and complete the aircraft's dynamics by incorporating a more comprehensive version of the phenomenon such as pitch axis oscillation and implementing a non-constant angle of attack by inserting the aircraft's polar for the evaluation of various force coefficients.

5. Conclusions

In this paper, we analysed the SORA process and simulate a Flight Termination System, like parachute, to demonstrate which M2 mitigation work appropriately. Our UAV operations denote a considerable yet controllable risk, as evidenced by the acquired values of GRC level of 3 and an ARC-B which involve in a SAIL value of 2. This value allows us to identify mandatory and optional OSOs. These OSOs, which cover different areas from UAV design and maintenance to pilot training, mission planning, and emergency management, have performed an important role in guaranteeing that UAV operate securely and in a reliable way. To meet the robustness of each OSO, additional mitigations and considerations must be taken into account which make all this process iterative. This iterative approach ensures that all aspects of the operation are thoroughly evaluated and addressed. The result show which Ground Impact Hazards are reduced, and simulation is used to verify the mitigation of the ground impact risk. Further improvement will be performed to the simulation model.

References

- [1] COMMISSION IMPLEMENTING REGULATION (EU) 2019/947 of 24 May 2019 on the rules and procedures for the operation of unmanned aircraft 2019 Official Journal L 152
- [2] Easy Access Rules: Unmanned Aircraft Systems (Regulation (EU) 2019/947 and Regulation (EU) 2019/945) 2022 EASA Document Library
- [3] Manta Air 2019 UAV and Drone Parachute Recovery - Manta Air [Online]. Available: https://manta-air.com/uav_safety_and_recovery_systems/. [Accessed: 12-Aug-2023].
- [4] Development, N. A. T. Organization. A. G. F. A. R. A., 1991, Design and Testing of High-Performance Parachutes.
- [5] Hume R G, 1973, "A Two - Dimensional Mathematical Model of a Parachute in Steady Descent," AERONAUTICAL RESEARCH COUNCIL.
- [6] Knacke T W, 1992, Parachute Recovery Systems, Para Pub.
- [7] Guglieri G 2012 Parachute-Payload System Flight Dynamics and Trajectory Simulation. *International Journal of Aerospace Engineering*, pp. 1–17.
- [8] Panta A et al 2018 Dynamics of a Small Unmanned Aircraft Parachute System. *Journal of Aerospace Technology and Management*, 10 8. <https://doi.org/10.5028/jatm.v10.752>.