

A new proposal for the Architectural Stratigraphic Analysis and the resulting diagram

*Original*

A new proposal for the Architectural Stratigraphic Analysis and the resulting diagram / Villalobos, Roberto. - In: ACTA IMEKO. - ISSN 2221-870X. - ELETTRONICO. - 13:2(2024). [10.21014/actaimeko.v13i2.1729]

*Availability:*

This version is available at: 11583/2988811 since: 2024-05-17T08:35:06Z

*Publisher:*

International Measurement Confederation.

*Published*

DOI:10.21014/actaimeko.v13i2.1729

*Terms of use:*

This article is made available under terms and conditions as specified in the corresponding bibliographic description in the repository

*Publisher copyright*

(Article begins on next page)

# A new proposal for the Architectural Stratigraphic Analysis and the resulting diagram

Roberto Villalobos<sup>1</sup>

<sup>1</sup> Dipartimento di Architettura e Design, Politecnico di Torino, Viale Pier Andrea Mattioli 39, Torino (TO), Italy

## ABSTRACT

The stratigraphic analysis is a non-destructive method based on archaeology that illustrates the relationships and sequences of the stratigraphic layers of excavations by listing all their constituting elements, to be later represented in a stratigraphic diagram. Although the constant improvements and applications of the stratigraphic analysis in several scientific fields since 1973, this study proposes specific modifications to the current method as well as an adaptation of the diagram scheme to each case study of conservation. The main goal of this study was the elaboration of a detailed and comprehensive diagram that encompasses the entire monument, rather than one for each individual section of the monument. The first step was the identification of the main stratigraphic units and their classification based on their primary function: structural or decorative. The second step concerned a simplification of the current relationships of the architectural units into three groups, according to their roles within the entire system to obtain a simpler stratigraphic sequence. The final step was the new incorporation of pathology-related information and the addition of the missing elements as a reconstruction process. These adjustments allowed the diagram to arrange all data gathered from heritage analysis and will permit historians, architects, archaeologists, and others to engage in a global reading of the built. The stratigraphic diagram will serve as a tool to visually represent the analysis and synthesis in a coded manner, which will be comprehensible to both the researchers and the scientific community.

**Section:** RESEARCH PAPER

**Keywords:** Stratigraphic diagram; stratigraphic units; stratigraphic sequence

**Citation:** R. Villalobos, A new proposal for the Architectural Stratigraphic Analysis and the resulting diagram, Acta IMEKO, vol. 13 (2024) no. 2, pp. 1-8. DOI: [10.21014/acta\\_imeko.v13i2.1729](https://doi.org/10.21014/acta_imeko.v13i2.1729)

**Section Editor:** Fabio Leccese, Università Degli Studi Roma Tre, Rome, Italy

**Received** December 15, 2023; **In final form** January 25, 2024; **Published** June 2024

**Copyright:** This is an open-access article distributed under the terms of the Creative Commons Attribution 3.0 License, which permits unrestricted use, distribution, and reproduction in any medium, provided the original author and source are credited.

**Corresponding author:** Roberto Villalobos, e-mail: [roberto.villalobos@polito.it](mailto:roberto.villalobos@polito.it)

## 1. INTRODUCTION

The Harris Matrix is the name given to a printed sheet of paper which contains a grid of rectangular boxes where all the elements found in the excavation should be listed. The resulting diagram represents the stratigraphic sequence of the site defined as “the order of the deposition of layers and the creation of interfaces that have divided those layers through the course of time” [1]. This method analyses the soil and wall periodization, the strata, and all the “finds” “by numbering the layers with the understanding that such enumeration allows the artefacts to be given a systematic provenance and seen to be peculiar to the stratum in which they were found”...“where the upper units of stratification are younger and the lower are older” [1]. The early implementation of the stratigraphic method in the study of standing structures consisted of the stratigraphic analysis of the masonry, which had the description and interpretation of the different construction phases as first objective [2]. Subsequently

the process came to be known as archaeology of architecture, when more sophisticated survey and measurement methods, such as mensiochronology and archaeometry, were added [3].

The archaeology of architecture has evolved in Italy since the 1970s. Edward Harris, is acknowledged as the creator of the stratigraphic study of walls, as archaeological site elements. However, the systematization and the development of the stratigraphic study of vertical structures are mainly due to a group of Italian architects who, from the beginning of the eighties, began the debate on the subject, publishing their work in the journal “Archeologia Medioevale” [4]. The stratigraphic lecture supports the restoration process by documenting and providing sufficient scientific information that allows material conservation, reducing the loss or elimination of the same [2]. Consist on analyzing the built to formulate hypothesis and understand all the phases of construction, the later interventions, the proportions, and how the elements are connected to recreate their history [5]. Is the reading of the currently visible building

walls, a process of identification and transcription of the data into plans, sections, isometrics, details, and all scale drawings to comprehend a specific part or the object as a whole [4].

But why the archaeology of architecture and the stratigraphic diagram are relevant? Because the data collected in the stratigraphic analysis constitute the material documents that allow the knowledge of the history of the building and, at the same time, make up the material of the construction that the designer could restore [5]. The overall procedure should be accompanied by an extensive knowledge of the elements composing the opera, of the historical background and the ancient constructive technique, and a familiarity with the diverse typologies [6]. Therefore, it is suggested to undertake the analysis in partnership with multiple experts, or by “an archaeologist who knows the history of architecture or, better, an architectural historian who has assimilated the conceptual tools of stratigraphic archaeology” [7]. Numerous trials of implementing this approach have disclosed a fundamental issue: the large number of diagrams obtained upon identifying all compounds within the system, along with the challenge of incorporating additional information, such as the degradation state or missing units, into a single schema. Doing so would render the current scheme incomprehensible and unmanageable in its size.

Although it is a first-order approximation tool, the main objective is to change its rigid scheme and suggest a new way of application to standing structures, to generate a more complete stratigraphic diagram rather than one diagram per each specific part. The idea is to not only identify and list the components of the building, but also order them according to the function and a specific chronology. It is worth remarking that there is a considerable literature on modifications made to Harris's original proposal. However, the present theoretical approach aimed to maximize the diagram's potential by adding as many variables as possible, using a case study simple in the number of units but complex in the way the information is placed in the matrix. It is important to point out that the possibilities are many, and in the future more details may be added to meet the objective of achieving a scheme capable of organizing all the information obtained from the heritage analysis and having a global reading of the object, where historians, architects, archaeologists, and others can participate. As mentioned before, the goal is to change the rigidity through the inclusion of more data and try to adapt the scheme to each specific case, enhancing its capability to manage a greater volume of information, all in a single matrix.

## 2. THE SCALE OF ANALYSIS AND THE REFERENCE UNIT

The Reference Unit (*Unità di riferimento*) is defined as the main element that is going to be studied, and it can be a whole (*complesso architettonico*) or a specific part (*elemento architettonico*), which allows the analysis of the vertical structure to be focused on different degrees, considering the scale of study as well. In the case of architectural monuments, it is to recognize the architectural elements that make up the object and to decide the scale of study: microstratigraphy which study each element individually or macrostratigraphy, focusing on bigger portions with similar characteristics [8]. However, the election of the degree of analysis depends also on the availability of the resources and on the main goal of the research [6]. The first step of this theoretical approach is the definition of stratigraphic units (USM) by the main function fulfilled within system, stop focusing on the relationships. Accordingly, the architectural element could be catalogized as structural or decorative. The Structural

Stratigraphic Units (USS) consider all the pieces that support the others or share the load, even if they are shaped or decorated, while the Decorative Stratigraphic Units (USD) bring together the parts that provide aesthetic characteristics. This reorganization into two main Reference Units is the result of a taxonomic classification based on the most important quality inherent in each element. As a result, the diagram would have the tools to recognize not only the constructive phases [6], but also the stylistic aspects, and the structural transformation and behavior.

The individualization into specific groups is not a new proposal. Gian Pietro Brogiolo considered the “*elemento architettonico*” as the single architectonic part of a construction, either structural, column or pillar, or decorative as a frieze, and added the “*unità stratigrafiche di rivestimento*” to represent the surface finishing or the plaster. In his proposal is possible to reduce the “*elemento architettonico*” into a necessary number of units that ensure the record of every single detail, but it will lead to create many diagrams and forget the main purpose of the study, i.e., the historical understanding of the whole monument [9]. The division into two groups provides a full lecture of the structural behavior and at the same time of the decorative characteristics, as well as the modifications caused by the time. It is not a recording of each element without a precise and clear methodology in a vague and improvised way, but rather to adapt the methodology to each specific case [2]. The method's evolution has always kept in mind how to adapt the stratigraphic archaeological diagram to heritage documentation, attempting to use the chart not as a mere list of elements found on site. It could be a tool that can provide the needed information to understand the entire monument and each specific part, useful for the redaction of a conservation project. Furthermore, the recognition of the elements as structural or decorative provides the option to group elements that share similar characteristics. Depending on the object size the scale of analysis could consider as a minimum unit a single (one column) or a group of elements, (a set of columns on a church) always based on the function performed.

An implementation was carried out over a curtain wall of the Aurelian Walls of Rome, specifically on the exterior facade between the towers L39 and L40 during the author's master thesis. A survey and analysis campaign were carried out to assess the state of the monument and to propose a restoration project with re-use purposes. The process consisted of direct dating (mensiochronology and a kind of chrono-typology) and indirect dating through the study of archives and other written sources. In Figure 1 the different steps of the heritage analysis procedure are recognizable: the photogrammetry, the architectural survey, the masonry mapping, and the degradation diagnosis, from which it was possible to identify the original parts and the subsequent interventions over time, as well as the state of conservation. Figure 2 provides instead detailed information on the different materials used in each phase of construction and their arrangement on site.

## 3. NEW STRATIGRAPHIC SEQUENCE

The stratigraphic sequence is the order in which the USM (in this case, USS and USD) are placed within the matrix. They follow a relative order of anteriority and posteriority [6], according to their location in the stratum and their physical connection with other units. The way the units are arranged in the matrix is given by the Law of Stratigraphic Succession

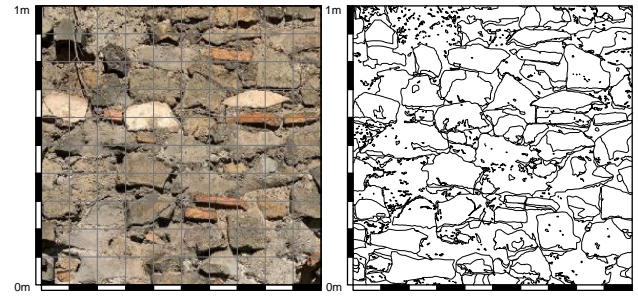

Figure 1. Direct documentation and representation of the Aurelian Walls of Rome, Towers L39-40: from the photogrammetry to the degradation analysis.

established by E. Harris, which considers only the most basic relationships between two units: above, below, or in contact with, where all other relationships are redundant [1]. Three types of relationships among the elements found in excavations were identified: 1, the units have no physical relationship; 2, they are in superposition; and 3, the units are correlated as parts of a once-whole deposit that has been modified [1]. The objective is to provide a first overview of the area and the features.

Once this method was applied to the understanding of vertical structure, it is possible that one USM could be younger than the USM that is physically above. Accordingly, a modification was necessary to order the components inside the diagram. Two groups were proposed according to their temporary physical contact: contemporaneity and antero-posteriority [10]. The first group includes the units that do not have physical contact but were built for similar purposes with similar constructive characteristics or were once united. The second group considers the following relations: on top of or supported by, attached to, covers a, fills a, and cuts to. The latter is usually related to covers by or filled by [10].

The difficulty arises when all these relationships are transferred to the matrix, as one or more units may have several relationships with others in the stratigraphic sequence. Therefore, it is important to reduce the relationships between the units as much as possible and thinking that the contact between the elements is due to a function. Each unit, USS, or USD contemplates three or four types of relationships. The first one is whether one unit touches the other: above, below, supported by, attached to, or cut to. The second type deals with the fact that an element represents a stage of intervention, conservation, maintenance, or restoration. Accordingly, one unit interact with the other one: it covers to, it protects to, or is a new element in



SAMPLE CODE	CLASSIFICATION	DATE			
N° 4 - OUTSIDE FACADE	--	XII-XIII centuries			
STATIC FUNCTION	STATE OF CONSERVATION	STRATIGRAPHIC RELATIONSHIP			
TOWER 40: LOWER PART	DISCRET	MEDIOEVAL INTERVENTION			
MATERIALS					
<b>STONE</b>	ORIGIN REUSE	TYPE PEPERINO	COLOR GRAY	SHAPE --	DIMENSIONS --
<b>BRICKS</b>	ORIGIN REUSE	--	COLOR RED	SHAPE RECTANGULAR	DIMENSIONS --
<b>MORTARS</b>	COLOR LIGHT GRAY	BINDER LIME	AGGREGATE --	AGGREGATE GRAVEL, CHALK OF STONEMAN PUMICE + POZZOLANA	CONSISTENCE AVERAGE JOINT --
MASONRY DISPOSITION IRREGULAR DISPOSITION, MIXING GRAY STONES, MARBEL, TRAVERTINE, GRAVELS AND FRAGMENTS OF TUFFA BLOCKS					
REMARKS VARIOUS BRICK INSERTIONS					

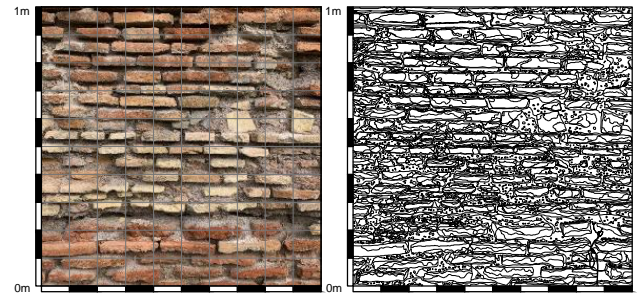

SAMPLE CODE	CLASSIFICATION	DATE			
N° 5 - OUTSIDE FACADE	OPUS LATERICIUM	LATER INTERVENTION			
STATIC FUNCTION	STATE OF CONSERVATION	STRATIGRAPHIC RELATIONSHIP			
WALL: NEAR THE GROUND	DISCRET	--			
MATERIALS					
<b>STONE</b>	ORIGIN --	TYPE --	COLOR --	SHAPE --	DIMENSIONS --
<b>BRICKS</b>	ORIGIN REUSE	--	COLOR FROM RED TO YELLOW	SHAPE RECTANGULAR	DIMENSIONS W: 9 - 21 cm H: 2,6 - 3,8 cm
<b>MORTARS</b>	COLOR GRAY	BINDER LIME	AGGREGATE --	AGGREGATE POZZOLANA	CONSISTENCE AVERAGE JOINT M: 2,9 cm m: 1,2 cm
MASONRY DISPOSITION HORIZONTAL COURSES, REUSED BRICKS TO COMPLETE THE MASONRY					
REMARKS IS POSSIBLE TO GET SOME SAMPLES OF TRIANGULAR SHAPE					

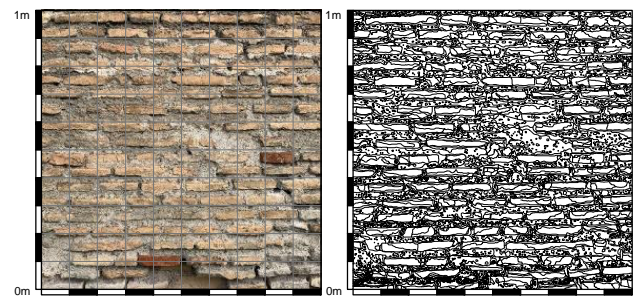

SAMPLE CODE	CLASSIFICATION	DATE			
N° 6 - OUTSIDE FACADE	--	271 - 275			
STATIC FUNCTION	STATE OF CONSERVATION	STRATIGRAPHIC RELATIONSHIP			
WALL	GOOD	FIRST PHASE			
MATERIALS					
<b>STONE</b>	ORIGIN --	TYPE --	COLOR --	SHAPE --	DIMENSIONS --
<b>BRICKS</b>	ORIGIN REUSE	--	COLOR FROM RED TO YELLOW	SHAPE RECTANGULAR	DIMENSIONS W: 7 - 26 cm H: 3 - 3,9 cm
<b>MORTARS</b>	COLOR GRAY	BINDER LIME OR CEMENT	AGGREGATE --	AGGREGATE POZZOLANA	CONSISTENCE AVERAGE JOINT M: 2,9 cm m: 1,5 cm
MASONRY DISPOSITION HORIZONTAL COURSES, BRICKS AND JOINTS SHARE SAME HEIGHT					
REMARKS BRICKS HAVE SAME SIZE, IS POSSIBLE TO UNDERSTAND THAT BRICKS BELONG TO SAME PHASE BUT WITH THE INTERVENTION OVER THE JOINTS					

Figure 2. Masonry analysis.

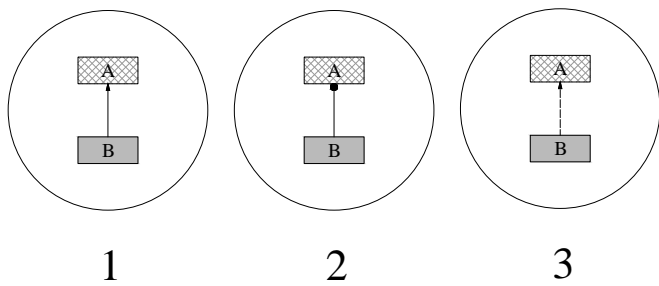

Figure 3. Graphical explanation of the modified relationships between units of architectural stratification.

contact with. The third type is the reading of the missing units, namely from the negative interface it is possible to read a unit that is no longer there but that was part of it. As Figure 3 shows, A is in contact with B, or B represents an intervention of A, then B could be a missing part of A, each situation per each USS or USD. A modification of the arrow and lines in the matrix can help to better understand the diagram.

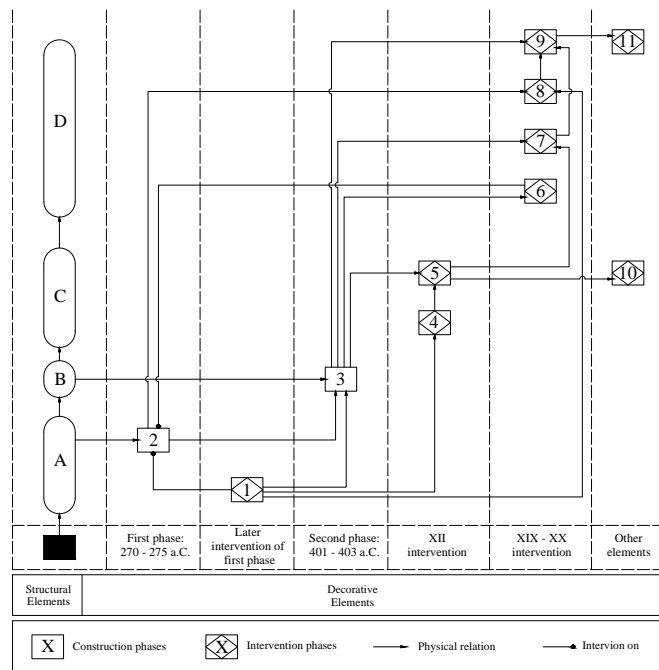
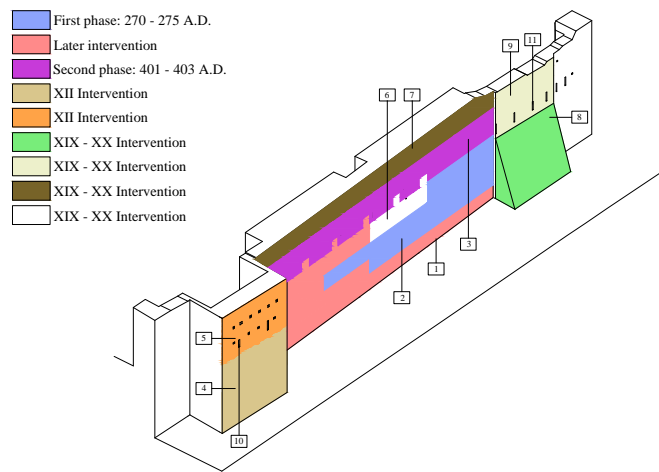

Figure 4. Resulting diagram considering the new types of interaction between units in a relative chronological sequence.

Let us focus on the example of the Aurelian Walls: the resulting diagram, in Figure 4, shows the elements grouped into decorative and structural. Letters A, B, C, and D correspond to the structural materials that represent the Roman concrete used as the inner core of the wall and the additions of XII, XIX, and XX centuries. Conversely, the numbers 1 to 11 belong to the decorative units: bricks and loopholes. The square and the square with a figure inscribed help to differentiate the planned phases of construction and the intervention phases. It was possible to link the letter A with the number 2 after an exhaustive investigation and in accordance with the masonry charts, since they are both made of original materials: Roman concrete covered in bricks. The same concept is true for the letter B and the number 3. The other letters and numbers are related to a certain period as well, but it was impossible to tell whether they were used at the same execution time. In this study, concrete and brick are not considered as a single load-bearing element; conversely, the concrete is assumed as a structural element and the brick coating a decorative element.

One of the earliest adjustments to the Harris method focused on the dating of the units and was applied by Martin Davis. He suggested that the “chronological late elements” should be placed in the diagram above the elements that are physically over them [11]. According to his statement, if a column or set of columns were added or replaced after the building was complete, they should be written over the number that represents on site the element on top; accordingly, the diagram would not illustrate the real position of the elements. It is a suggestion to add the variable of time when the diagram is in process of elaboration, even if it is just a relative chronology. In this proposal time was added in the lower part of the diagram, while the units must be located in the columns they could belong to. A continuous line with a circle will identify if one unit is an intervention of another, as shown in Figure 4 with the number 1 and 2. Furthermore, it is considered for this approach to change the symbol that contains the number and specify in the legend that there is an intervention phase that could have occurred after the following period, presenting a diagram that faithfully represents the actual on site situation with proper correlation of function and a relative time connection.

#### 4. STRATIGRAPHIC UNITS OF PATHOLOGIES (USP)

Despite the previous steps show a different way to classify and organize the units of the vertical structures, the information is still the same as that reflected by other proposals to configure the stratigraphic diagram. Accordingly, more data should be included to obtain a diagram that truly displays all the information resulting from the documentation stage. The new aspect of this proposal is that degradation agents are considered other types of units that are present in constructions since they have the function of “damaging” the elements mentioned above. The pathogenic agents are assumed as phenomenon that affect the material causing its lost or alteration. For a proper explanation, it is needed a specific table with the information of each agent, not just their description and location, but to understand its cause [12].

The “Unità Stratigrafiche Post deposizionali” (UP) was defined as the transformations that occurred in the construction due to actions of detachments, disruptions or degradation, after the end of the construction [1]. According to Brogiolo this unit can be referred to crack pattern, deformations and/or physical chemical and anthropic alterations over time. Another proposal that aimed

to include the degradation as stratigraphic units was developed by Giovanni Leonardi and his team in Padova. They suggested the “*unità di trasformazione*” understood as a specific problem that affect a single unit or part of the construction in a specific period, or as a group of pathologies that transformed a group of units in a synchronic manner [8].

The suggestion of this proposal is to combine all the types of pathologies, assuming that they should share similar characteristics or provenances. All the pathologies affecting the studied object were obtained from the degradation diagnosis (see Figure 5). Each description includes the cause, the effect, and the possible method to reverse the problem. Green pathologies composed the first group, and includes the vegetation on top (1), the ground vegetation (2) and the dried plants: all of them can be removed mechanically and/or by using herbicides. Other members of this group are the biological agents such as mosses or algae. The affectations originated by the presence of water (efflorescence, sub florescence, water filtration, rain, etc.) belong to the second group. In the case of the exterior facade of the Aurelian Wall (same case of study) there is just one pathology originated strictly by the presence of water: efflorescence (6). A third group is composed of the ones which represent the loss or physical modifications of material by mechanical or chemical processes: loss of mortar (4), blistering (5), deposit (7), soling (8), powdering and weathering (9). The fourth group contains the structural or decorative modifications/affectations caused by nature or human activities: cracks or fractures, inappropriate integrations, graffiti, etc.

The inclusion of pathologies as stratigraphic units provides historical information about the affectations that monument suffers and their duration. It is important that whoever is in charge has prior training on heritage analysis or has participated in previous campaigns. The objective of this re-organization of the method is to show a full reading of the monument as much as possible. As well as its elements and its current state in an easier and faster

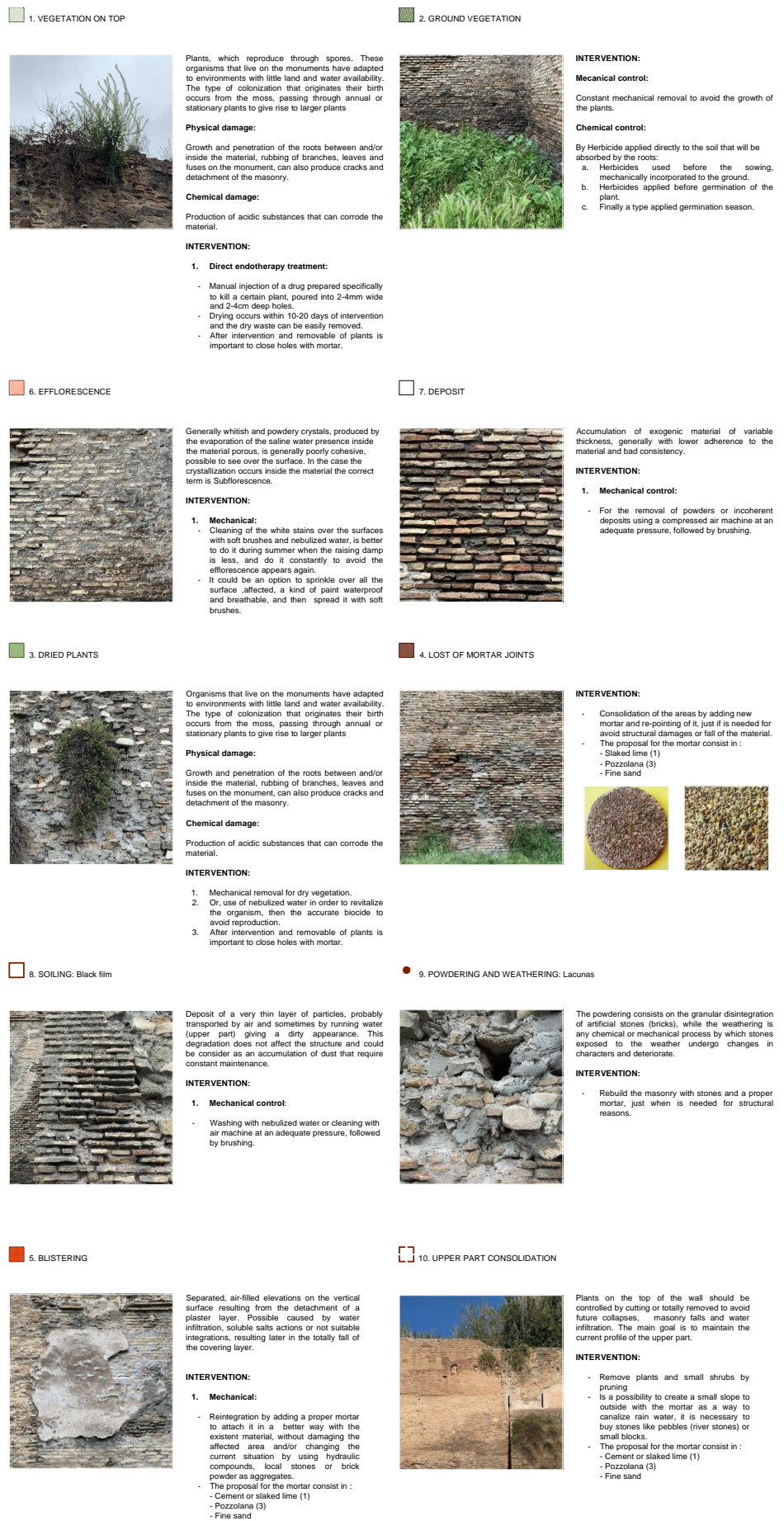

Figure 5. Recognition of the pathologies present on the façade of the wall before include each of them in a specific group.

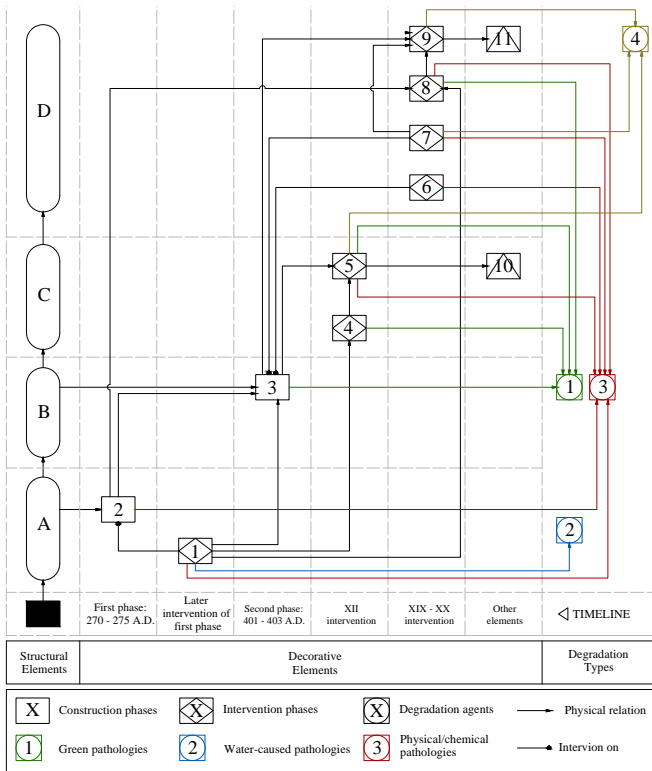

Figure 6. Stratigraphic diagram including the types of degradation.

way (see Figure 6). In this way the possibilities of the diagram are expanded, as well as its capability to manage, order, and display more data than just the elements that compose each stratigraphic layer.

### 5. RECONSTRUCTED UNITS

The study of the USS or USD through, for instance, mensiochronology allows establishing an absolute chronology of each element individually through the comparison of the objects of study with others previously catalogued and a relative chronology of the constructive phases of the monument. It is possible to identify which units were made specifically for the activity at hand and which others may have been utilized for any intervention stage thanks to this kind of examination. This procedure allows to order all the USS chronologically, from the oldest to the newest (vertically), and the USD to have double readings from bottom to top and left to right. In this way, a timeline-like feature may be added to the diagram, in which the elements are placed with a time criterion. Having some precise data in a related chronological scheme is beneficial. It is just at this moment that missing elements or reconstructed units can be added in a pertinent part of the diagram, because they will provide information about the transformation of the monument.

The reconstructed units are elements that are no longer in existence but were rebuilt using hypothesis that appeared as the result of the survey of the “negative stratigraphic units”, a surface which indicates a missing volume [13]. Emanuel Demetrescu, in his paper *Archaeological Stratigraphy as a formal language for virtual reconstruction*. Theory and practice, mentioned that missing parts can be re-constructed by analyzing the physical surface destroyed. An example at hand are the broken ancient friezes, a marble fragment indicates that the missing element that completed the frieze was done with the same material. The first type of re-constructed units is called “structural gaps”,

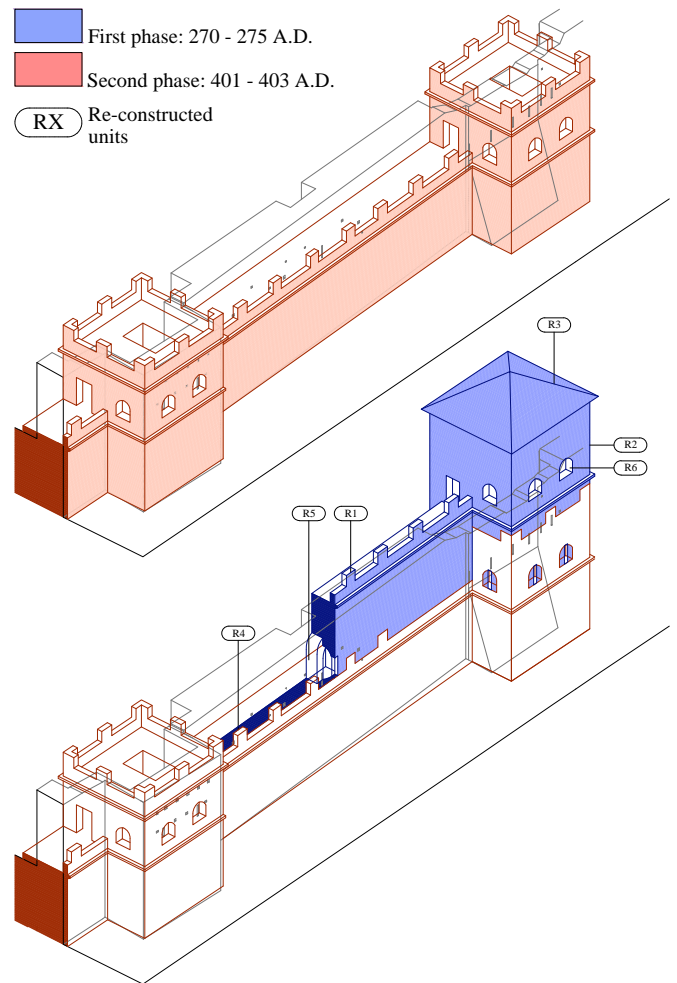

Figure 7. Reconstruction hypothesis after indirect survey and observation of the remains.

“information directly related to a tangible unit” [13]. A second group is called “non-structural gaps”, and refers to the elements that are assumed to have been located in such a position only by the analysis of other sources.

Following with the same case of study, a good example of a negative stratigraphic unit is the surface on top of the Aurelian Wall. If the specialist observes carefully the discontinuity of the current upper part it is possible to assume that there is a missing piece, a structural gap that completed the wall, which can be confirmed by the archives or bibliographic resources, as well as the other parts of the wall. As an exercise and to exemplify a non-structural gap unit, let’s consider this curtain wall as the unique preserved remain. Only archives might confirm that the upper missing element was a Battlement: a set of parapets and merlons with a rampart-walk at the back. Figure 7 illustrates the reconstruction of the two phases of construction of the Aurelian Wall after proper reading of archives, bibliography, and figures (indirect dating), and Figure 8 the completed diagram with the inclusion of the stratigraphic units of the inner façade (which followed same process of analysis and scheme elaboration), and the possible time variable. As shown in Figure 8, it is possible that the diagram provides two stratigraphic sequences: the first one is the current stratigraphic sequence, while the second consists of the original stratigraphy of the monument.

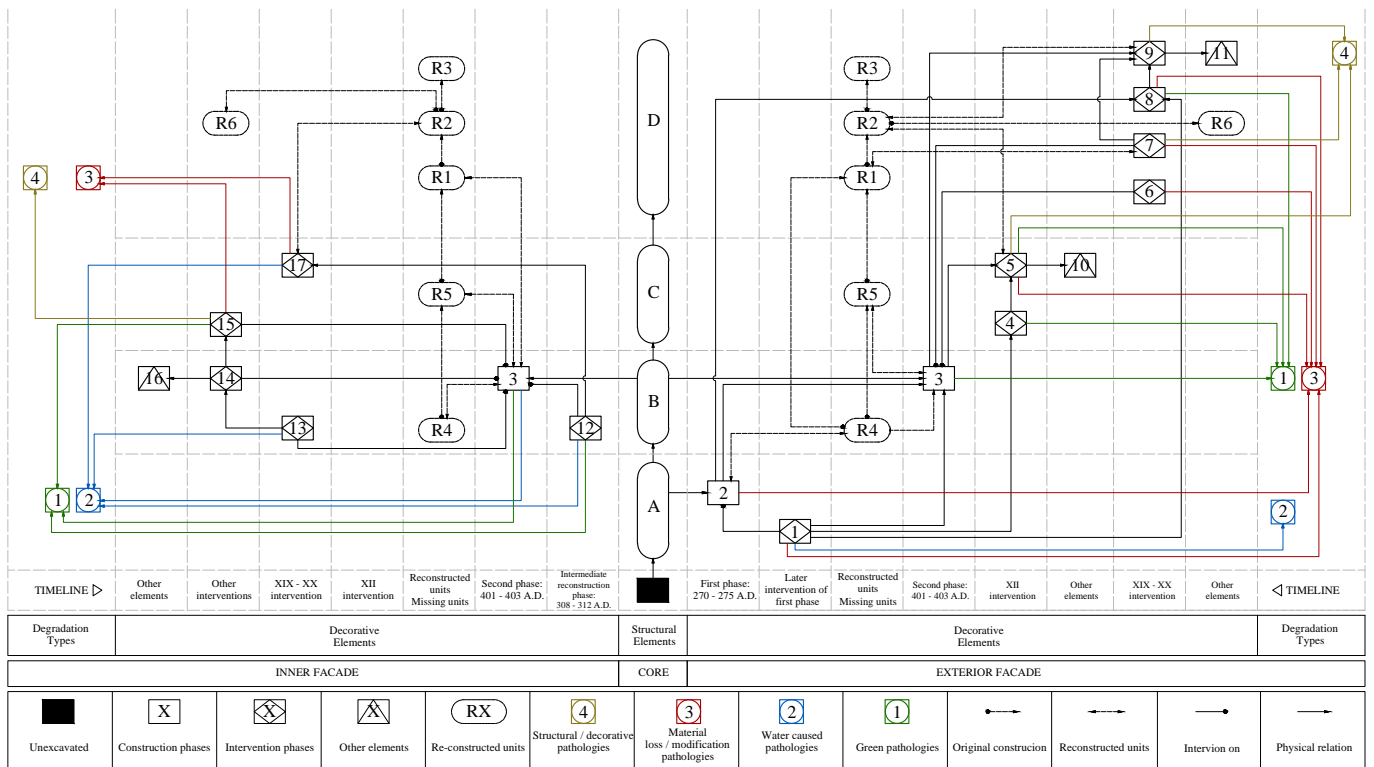

Figure 8. Full diagram.

## 6. CONCLUSIONS

This new approach to stratigraphic analysis of architecture is proposed to rethink the theory and unify the symbology and way of working to establish the same application system. The stratigraphy and the stratigraphic diagram are presented as tools that are part of the development of the restoration project. It is necessary to formalize a unified and unambiguous language that allows not only to correctly select, interpret, and transmit the historical data or the object of study itself, but also to understand the built material and the natural and anthropogenic changes as great sources of information [12]. It is not possible to restore a building without knowing the characteristics in detail and in depth. This is how the construction itself, tangible material consistency, is assumed as a source of knowledge [14].

In this way, data are not obtained through syllogisms or abductions [15], but rather the conclusions are the result of observation and the formulation of hypotheses. The first step is to understand the USM (USS and USD) not as in archaeology but as elements that fulfill a function within a complex system and that, based on these functions, they are grouped and establish relationships. The law of stratigraphic succession applied to the "built" identifies every unit in a stratigraphic layer and arranges them in the diagram in a particular order based on the relationship it has with other units, i.e., not only whether it is above or below, but also whether it represents a restoration or intervention act, or a reconstructed element that was once part of another unit but is no longer present. Based on this understanding, the paper suggests adding the time variable to create a kind of chronological order and simplifying the interactions between the units. Thus, it is possible to obtain a diagram that is the result of an analysis that differs from that of archaeology, representing a three-dimensional object in a two-dimensional diagram. This proposal aims to read vertical

structures where the stratigraphic laws of archaeology are not applicable or that require a re-theorization. This simplification process does not include documentation of interfaces or negative units. Interfaces allow specialists to understand where an element is cut, where a construction process ended, or where an intervention exists, so the three established relationships already include the interfaces. While the negative units are transformed into reconstruction units obtained from guesses and analysis of the files.

The stratigraphic diagram of architecture makes a contribution by not only identifying the components of the building but also by allowing for their order to be determined by the function based on the disposition on site. On this basis, it is able to identify the various stages of construction or the subsequent interventions, and the transformations through time. As a result, the diagram will show an absolute order instead of a relative one; therefore, it will be possible for anyone to read the elements, understand their function, realize their state and comprehend the monument's former or original image, as well as dispose them with proper correlation of anteriority, posteriority or contemporaneity [11]. The idea is to adapt the scheme as much as possible to each specific case.

Although it is true that there is a considerable bibliography on modifications to Harris's initial proposal, this theoretical approach looked to fully exploit the diagram's potential by adding as many variables as possible using a case of study simple in the number of units but complex in the way in which the information is placed in the matrix. It is important to point out that the possibilities are many, and in the future more details may be added to meet the objective of achieving a scheme capable of organizing all the information obtained from the heritage analysis and having a global reading of the object, where historians, architects, archaeologists, and others can participate. As mentioned before, the goal of this paper was to change the

rigidity through the inclusion of more data and enhance its capacity to manage a greater volume of information, all in a single matrix.

## REFERENCES

- [1] E. Harris, *Principles of archaeological stratigraphy*, 2<sup>nd</sup> Edition, Academic Press, California, USA, 1989.
- [2] C. Mileto, Algunas reflexiones sobre el Análisis Estratigráfico Murario, *Loggia, Arquitectura & Restauración*, vol.9 (2000), pp. 80–93. [In Spanish]  
DOI: [10.4995/loggia.2000.5265](https://doi.org/10.4995/loggia.2000.5265)
- [3] C. Mileto, F. Vegas, El análisis estratigráfico constructivo como estudio previo al proyecto de restauración arquitectónica: metodología y aplicación, *Arqueología De La Arquitectura*, vol.2 (2003), pp. 189-196. [In Spanish]  
DOI: [10.3989/arq.arqt.2003.46](https://doi.org/10.3989/arq.arqt.2003.46)
- [4] G. P. Brogiolo, L'archeologia dell'architettura in Italia nell'ultimo quinquennio (1997-2001), *Arqueología De La Arquitectura*, vol. 1 (2002), pp. 19-26. [In Italian]  
DOI: [10.3989/arq.arqt.2002.3](https://doi.org/10.3989/arq.arqt.2002.3)
- [5] C. Mileto, F. Vegas, El análisis estratigráfico constructivo y el proyecto de restauración, *Arqueología De La Arquitectura*, vol. 3 (2004), pp. 155-162. [In Spanish]  
DOI: [10.3989/arq.arqt.2004.67](https://doi.org/10.3989/arq.arqt.2004.67)
- [6] G. P. Brogiolo, A. Cagnana, *Archeologia dell'architettura: metodi e interpretazioni*, Edizione All'Insegna del Giglio, Firenze, Italy, 2012. [In Italian]
- [7] G. P. Brogiolo, *Arqueología estratigráfica y restauración, Informes de la construcción*, vol.46 (1995), pp. 31–36. . [In Spanish]  
DOI: [10.3889/ic.1995.v46.i435.1095](https://doi.org/10.3889/ic.1995.v46.i435.1095)
- [8] S. Beltramo, *Stratigrafia dell'architettura e ricerca storica*, Carocci editore, Roma, Italy, 2009. [In Italian]
- [9] C. Tosco, Una proposta di método per la Stratigrafia dell'architettura, Edizione All'Insegna del Giglio, Firenze, Italy, vol. 9 (2003), pp. 17-28. [In Italian]
- [10] A. Azkarate Garai-Olaun, C. Doménech-Belda, S. Escribano-Ruiz, S. Gutiérrez Lloret, D. M. Kiss, I. Sánchez Pinto, J. L. Solaun Bustinza, *Arqueología de la Arquitectura. Una experiencia práctica para el análisis arqueológico de edificios históricos*, Instituto Universitario de Investigación en Arqueología y Patrimonio Histórico (INAPH) Alicante, España, 2022. Online [Accessed 7 May 2024] [In Spanish]  
<http://hdl.handle.net/10045/130142>
- [11] D. Martin, *The Archaeology of Standing Structures*, *Australian Journal of Historical Archaeology*, vol. 5, pp. 54-64. Online [Accessed 7 May 2024]  
<http://www.jstor.org/stable/29543184>
- [12] F. Doglioni, *Stratigrafia e Restauro. Tra conoscenza e conservazione dell'architettura*, Edizione LINT Trieste, Italy, 1997. [In Italian]
- [13] E. Demetrescu, Archaeological stratigraphy as a formal language for virtual reconstruction. Theory and practice, *Journal of Archaeological Science*, vol.57 (2015), pp.42-55.  
DOI: [10.1016/j.jas.2015.02.004](https://doi.org/10.1016/j.jas.2015.02.004)
- [14] A. Boato, *L'archeologia in architettura. Misurazioni, stratigrafie, datazioni, restauro*, Italy, 2008. [In Italian]
- [15] D. Gallina, Sillogismo deduttivo o adduzione? Alcune porposte per l'abbandono/superamento del matrix di Harris nell'analisi dell'architettura, VI Congresso Nazionale di Archeologia Medievale, Edizione All'Insegna del Giglio, Firenze, Italy, 2012, pp. 75-78. Online [Accessed 7 May 2024] [In Italian]  
<https://hdl.handle.net/10807/28625>