

POLITECNICO DI TORINO
Repository ISTITUZIONALE

A parametric model for thermal management system for more electric and hybrid aircraft

Original

A parametric model for thermal management system for more electric and hybrid aircraft / Caggese, S.; Fioriti, M.; Di Fede, F.. - 37:(2023), pp. 76-79. (Intervento presentato al convegno 27th Congress of the Italian Association of Aeronautics and Astronautics, AIDAA 2023 tenutosi a Padova nel 2023) [10.21741/9781644902813-17].

Availability:

This version is available at: 11583/2988389 since: 2024-05-10T09:25:39Z

Publisher:

Association of American Publishers

Published

DOI:10.21741/9781644902813-17

Terms of use:

This article is made available under terms and conditions as specified in the corresponding bibliographic description in the repository

Publisher copyright

AIP postprint versione editoriale con licenza CC BY/Version of Record with CC BY license

Copyright 2023 Author(s). This article is distributed under a Creative Commons Attribution (CC BY) License <https://creativecommons.org/licenses/by/4.0/>."

(Article begins on next page)

A parametric model for thermal management system for more electric and hybrid aircraft

Sofia Caggese^{1,a*}, Marco Fioriti^{1,b} and Flavio Di Fede^{2,c}

¹Department of Mechanical and Aerospace Engineering, Politecnico di Torino, C.so Duca degli Abruzzi n.24, Turin, Italy

²Leonardo Labs, Future Aircraft Technologies, Leonardo S.p.A., c.so Castelfidardo 22, 10138 Turin, Italy

^asofia.caggese@polito.it, ^bmarco.fioriti@polito.it, ^cflavio.difede.ext@leonardo.com

Keywords: Thermal Management System, Hybrid Aircraft, Liquid-to-Liquid Heat Exchanger, Nanofluid

Abstract. In the last decade, the hybrid and electric propulsive systems have been gaining increasing interest to cut down greenhouse gas emissions and thus reduce the environment impact of the aerospace sector. The paper reports the development of a parametric model to design and simulate the Thermal Management System (TMS) of an hybrid electric regional aircraft. Considering the need for a compact design and avoiding the generation of additional drag, a liquid-to-liquid offset strip fin surface heat exchanger is selected. Analysis and modelling of the system are performed for both traditional and innovative coolant, namely, as nanofluids. Five different thermal load conditions are analyzed, which correspond to five different levels of hybridization defined in terms of reduction of CO₂ emission. The most demanding one entails a reduction up to 50% of CO₂ and a thermal load of 67.2 kW to be dissipated. The paper also aims to investigate the most challenging conditions for TMS design and whether the suitability of nanofluids as superior heat carriers. In fact, using nanofluids it is possible to reduce the size of heat exchanger, thanks to the higher thermal conductivity compared to conventional coolant.

Introduction

The primary concerns for climate change are emission of CO₂, NO_x and non-volatile particulate matter (nvPM). In 1983 ICAO Council established the Committee on Aviation Environmental Protection (CAEP), as technical assistant to formulate new strategies and to adopt new Standards and Recommended Practices (SARPs) related to international civil aviation noise and emissions [1]. In 2019, the European Parliament declared a climate emergency and established the European Green Deal. The main goals are to reduce emissions by 55% by 2030 and to achieve net carbon neutrality in Europe by 2050, in order to limit global warming below the 1,5 °C rise [2]. The aviation target is to halve emissions from 2005 levels by 2050. To reach this task new technologies and policies are improved. Electrified systems, biofuels, synfuels, hydrogen, fuel cells, electric motors and batteries are potential sustainable solutions[1]. One of the main challenges is the thermal power control and dissipation of new adopted propulsive system. The Thermal Management System (TMS) is the appropriate system to accomplish these tasks. The TMS acquires, through heat acquisition techniques, the generated thermal power from the heat sources and transfers it, through heat rejection mechanisms, to the terminal heat sinks. The new components needed to implement the electrified propulsion systems, such as the electric motor, the PEM fuel cell, and the battery, are sources of “low grade” heat [2]. For the traditional thermal engine, the heat load is higher than the new heat sources, due to the lower efficiency, but it is directly dissipated from combustion gases. Consequently, for traditional aircraft, little attention is paid to the TMS design. Therefore, the waste heat temperature of low-grade heat source is lower than traditional propulsive system. The absence of exhaust gases is a limitation for the new adopted

heat sources and the thermal load to dissipate could exceed one megawatt. Traditionally, aircraft TMS adopts ram air cooling system or liquid cooling system using water, oil or fuel. Heat exchanger is the major implemented device in both conventional and innovative propulsive system. Especially compact heat exchangers are used into aerospace applications [4]. The reference aircraft is a regional aircraft with parallel hybrid propulsion system [5].

Architecture and design

The devised concept features a liquid cooling system involving a coolant, such as water-ethylene glycol mixture, in the main loop, and fuel as the working fluid in the second loop. The main loop transfers the thermal load from the heat source to the liquid-to-liquid heat exchanger, while the second loop transfer it from the heat exchanger to the heat sink. Using fuel as the working fluid, wing fuel tanks are used as terminal heat sinks. The fuel is taken from the hub of the wing tanks and, after the heat exchange with the coolant, it is then returned to the tip of the wing tanks. A schema of TMS concept is reported in Fig. 1.

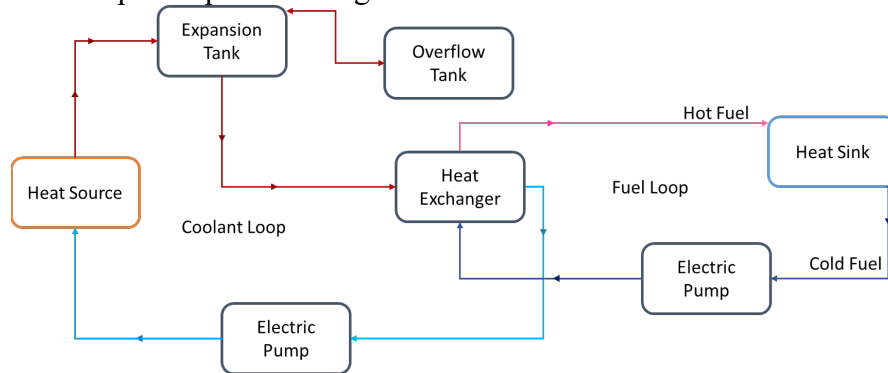

Fig. 1 – Simplified schema for architecture of liquid cooling system

The work aims to design a parametric model of a liquid-to-liquid heat exchanger and to integrate it into the TMS. The heat exchanger is a device that allow heat exchange between two fluids operating at different temperatures. The design differs according to the field of application. In the aerospace domain, the use of compact heat exchangers, characterized by small volumes due to lamellar surfaces that expand the heat exchange surface area, is favoured. The developed device is an offset strip fin surface heat exchanger, considering their typical compactness, with unmixed crossflow arrangement. Sizing is implemented through an iterative python code. At each iteration, the heat exchanger grows in the three dimensions to reach the size to satisfy the design temperature convergence. Type of internal geometry, types of fluids involved in, inlet temperature of both fluids and relative mass flow rates are input required by the parametric model. As output, the python script provides the spatial dimensions, effectiveness, volume and mass of the heat exchanger, core pressure drop, outlet temperature and regimes established of the two fluids involved, and also addresses the system electric consumption, distribution pipe’s characteristics and overall TMS mass. The effectiveness-NTU method is used as design approach for heat exchanger. The model is based on the formulation presented by [4]. Effectiveness, ϵ , is defined as

$$\epsilon = \frac{\dot{Q}}{\dot{Q}_{max}} = \frac{C_h(T_{h,i} - T_{h,o})}{C_{min}(T_{h,i} - T_{c,i})} = \frac{C_c(T_{c,o} - T_{c,i})}{C_{min}(T_{h,i} - T_{c,i})}, \quad (1)$$

where C_c and C_h are respectively the cold and hot stream heat capacity rates, $T_{h,i}$ and $T_{h,o}$ indicate inlet and outlet hot stream temperatures, $T_{c,i}$ and $T_{c,o}$ indicate inlet and outlet cold stream temperatures. Defining NTU, the number of thermal units, ϵ -NTU relationship (Eq. 2) can be used.

$$\epsilon = f(NTU, C^*) = f\left(\frac{UA}{C_{min}}, \frac{C_{min}}{C_{max}}\right). \quad (2)$$

ϵ -NTU relationship differs for each configuration, for crossflow arrangement configuration is:

$$\epsilon = 1 - \exp \left\{ \frac{NTU^{-0.22}}{C^*} [\exp(-C^*NTU^{0.78}) - 1] \right\} \quad (3)$$

Test case

Analysis and modelling of the system are performed for the electric motor and the inverter as heat sources. The selected heat source sets the design temperature for coolant convergence loop. The outlet coolant temperature from the heat source is 90 °C and the inlet coolant temperature in the heat source is expected to reach 65 °C. The analyses are performed in hot day condition for both ground and ceiling conditions (FL250), considering both traditional and innovative coolant, respectively 40% water-ethylenic glycol mixture and nanofluids. Both heat source and heat exchanger are located into the engine nacelle, and the heat sinks are represented by wing tanks, so 80% of wingspan is considered as distance to be covered by fuel. The five test cases represent the requirements for five different levels of hybridization, corresponding to a progressive reduction in carbon dioxide emissions due to the increased propulsive power generated from electric motor at the expense of conventional propulsion. They are proposed to evaluate the operation of liquid cooling system with several levels of thermal load, as indicated by Table 1.

Table 1 – Test Case Input

Test case	ΔCO_2	Thermal power EM+PE [kW]		TMS coolant mass flow [kg/s]	
		Take Off	Ceiling	Take Off	Ceiling
Test case 1	-10%	14.3	14.3	0.136	0.136
Test case 2	-20%	28.3	28.3	0.270	0.270
Test case 3	-30%	41.2	41.2	0.393	0.393
Test case 4	-40%	54.2	54.2	0.517	0.517
Test case 5	-50%	67.2	67.2	0.641	0.641

Fig. 2 reports the sizing script outputs: ground condition in blue line, ceiling condition in green line. Each dot depicts a test case. The dimensioning condition is identified in Test case 5, -50% CO2 emission, in the ground condition.

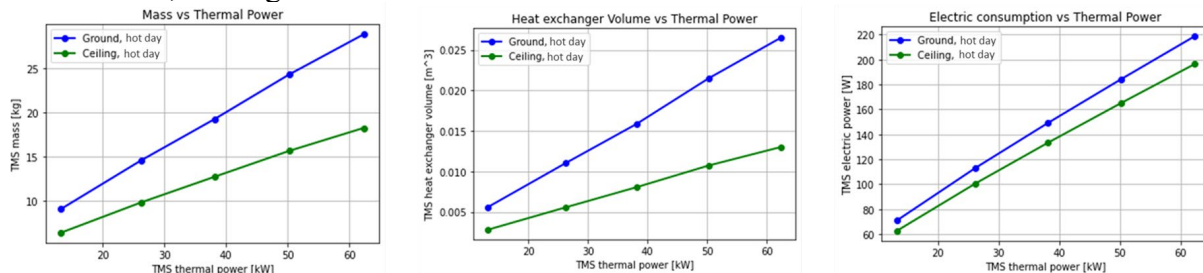

Fig. 2 – Test Case Output

The mass of heat exchanger is 6.6 kg, that is 22.7% of overall TMS weight, 28.9 kg and its volume is 0.026 m³. The electric consumption amounts to 219 W, distributed in 135 W required by coolant loop dedicated electric pump and 84 W required by fuel loop dedicated electric pump. Table 2 reports significant output of heat exchanger model for test case 5 at ground level.

Table 2 - Test Case 5 output: ground condition

Output Test Case 5 - ground					
Efficiency	[-]	0.450	Volume	[m³]	0.026
Pressure Drop - coolant	[Pa]	244.307	Length side 1	[m]	0.325
Pressure Drop - fuel	[Pa]	311.548	Length side 1	[m]	0.325
Weight	[kg]	6.56	Height	[m]	0.251

A sensitivity analysis is performed for three values of fuel mass flow rate, a design parameter. The increase in fuel flow rate achieves a reduction on heat exchanger mass of 15.8% and a 15.5% reduction on volume, but with an 11.4% increase on electric consumption. Despite the lower weight of the heat exchanger, due to the other components of the TMS, the TMS overall mass does not achieve the same benefit.

Nanofluids

Nanofluids are a new class of nanotechnology. Escalating interest of the last decade is based on the higher thermal conductivity compared to conventional coolant. They are engineered by suspending nanoparticles (1-100 nm) in a base fluid, such as water, oil, mixture of water and ethylenic glycol or traditional heat transfer fluids. The goal is to reach a significant improvement in thermal properties by a uniform and stable suspension of nanoparticles, thanks to a small concentration, less than 1% by volume. A lot of experiments are reported in the state of the art [5] of nanofluids coolant, with ceramic oxides nanoparticles, metallic carbides, metals, carbon nanotubes and others and for each of them experimental equations are presented. In this work, theoretical thermophysical equations are adopted, as defined in Chapter 5 of [5] Thanks to 0.502% of Al_2O_3 , TMS obtains a mass reduction of 10% and a smaller heat exchanger. Different types of nanoparticles at different concentrations are tested. The best case resulted in a 12% overall weight loss and 15% heat exchanger volume reduction.

Conclusion

The developed parametric model provides the design of a liquid-to-liquid heat exchanger integrated into TMS concept. For the most demanding test case, over 67 kW to be dissipated, the overall TMS weight is 29 kg and the heat exchanger volume is 0.026 m³. The sensitivity analysis reports, by increasing the fuel flow rate, an increase in the electrical power required by the electric pumps, a marked reduction in the heat exchanger dimensions and a slight reduction of TMS mass. If the purpose of design is volume optimization, the increasing fuel flow rate is promising, without achieving significant mass benefits. The use of nanofluids offers a good potential, but presently, not so great as promise in state of the art. Further investigation is needed to better understand the interactions between nanoparticles and base fluids and to predict the actual behavior.

References

- [1] ICAO, 2019 Environmental Report, Aviation and Environment, [https://www.icao.int/environmental-protection/Documents/ICAO-ENV-Report2019-F1-WEB%20\(1\).pdf](https://www.icao.int/environmental-protection/Documents/ICAO-ENV-Report2019-F1-WEB%20(1).pdf)
- [2] <https://eur-lex.europa.eu/legal-content/EN/TXT/HTML/?uri=CELEX:52019DC0640>
- [3] A.S.J. van Heerden, D.M. Judt, S. Jafari, C.P. Lawson, T. Nikolaidis, D. Bosak, Aircraft thermal management: Practices, technology, system architectures, future challenges, and opportunities, (2021). <https://doi.org/10.1016/j.paerosci.2021.100767>
- [4] J. E. Hesselgreaves, R. Law, D. Reay, Compact Heat Exchangers. Selection, Design and Operation, 2nd ed., Elsevier Ltd, 2017. <https://doi.org/10.1016/B978-0-08-100305-3.00002-1>
- [5] <https://www.clean-aviation.eu/about-us/who-we-are>
- [6] S. K. Das, S. U. S. Choi, W. Yu, T. Pradeep, NANOFUIDS, Science and technology, Wiley, 2008. <https://doi.org/10.1002/9780470180693>