

Reading, Transmission, Storage, and Display of Near Real-Time Data Acquired by Fiber Bragg Grating Sensors Installed on an Unmanned Aerial Vehicle

*Original*

Reading, Transmission, Storage, and Display of Near Real-Time Data Acquired by Fiber Bragg Grating Sensors Installed on an Unmanned Aerial Vehicle / Marceddu, ANTONIO COSTANTINO; Montrucchio, Bartolomeo. - ELETTRONICO. - 42:(2024), pp. 47-50. (Intervento presentato al convegno IV Aerospace PhD-Days tenutosi a Scopello, Sicily (ITA) nel 6-9 May 2024) [10.21741/9781644903193-11].

*Availability:*

This version is available at: 11583/2987730 since: 2024-06-03T14:18:03Z

*Publisher:*

Materials Research Forum LLC

*Published*

DOI:10.21741/9781644903193-11

*Terms of use:*

This article is made available under terms and conditions as specified in the corresponding bibliographic description in the repository

*Publisher copyright*

(Article begins on next page)

# Reading, transmission, storage, and display of near real-time data acquired by fiber Bragg grating sensors installed on an unmanned aerial vehicle

Antonio Costantino Marceddu<sup>1,a,\*</sup>, Bartolomeo Montrucchio<sup>1,b</sup>

<sup>1</sup>Politecnico di Torino, Corso Duca degli Abruzzi 24, 10129 Torino, ITALY

<sup>a</sup>antonio.marceddu@polito.it, <sup>b</sup>bartolomeo.montrucchio@polito.it

**Keywords:** Aerospace, Computer Graphics, Data Visualization, Database, Fiber Bragg Grating, Graphical User Interface, Middleware, Optical Fiber, Remotely Piloted Aircraft, Wireless Communication

**Abstract.** Fiber Bragg grating (FBG) sensors are a particular type of optical sensor capable of measuring multiple physical properties, like strain, temperature, and vibration. Their properties are of great interest for several use cases, including telecommunications, security, medicine, and biotechnology. This paper will discuss the progress of a project that uses them to monitor the health of an instrumented Unmanned Aerial Vehicle (UAV). Such operation is carried out on the ground in near real-time using software for intuitive data visualization.

## Introduction

Optical fibers are thin, flexible strands of glass or clear plastic used to transmit light signals over long distances with minimal loss of signal strength. They have a layered structure:

- In the innermost part is the core, where the light signal travels.
- Next is the cladding, which has a composition that maximizes internal reflection and prevents light from escaping from the core so it can travel through the fiber.
- Finally, there are one or more polymer coatings that have a protection function from environmental and mechanical agents.

Inside the core, it is possible to carry out a periodic modulation of the refractive index. These changes modify the light passing through the fiber, causing it to reflect a specific wavelength of light called the Bragg wavelength. This microstructure is called Fiber Bragg Grating (FBG) and can be used as a sensor to measure various engineering parameters such as temperature, strain, vibration, pressure, and load. Fig. 1 depicts the FBG operation principle. The advantages optical fibers offer, such as lightweight and small size, immunity to electromagnetic interference, and reliability, make FBG sensors suitable for different applications, such as Structural Integrity Monitoring (SHM), medical sensing and imaging, environmental monitoring, and more. These applications are then widely used in geodynamics, telecommunications, civil structural engineering, the energy industry, and aerospace [1-11].

This paper precisely concerns this last example, as it deals with a research project concerning the use of FBG sensors for the structural monitoring of an Unmanned Aerial Vehicle (UAV). It will be discussed in detail in the next section.



### Flying test bench

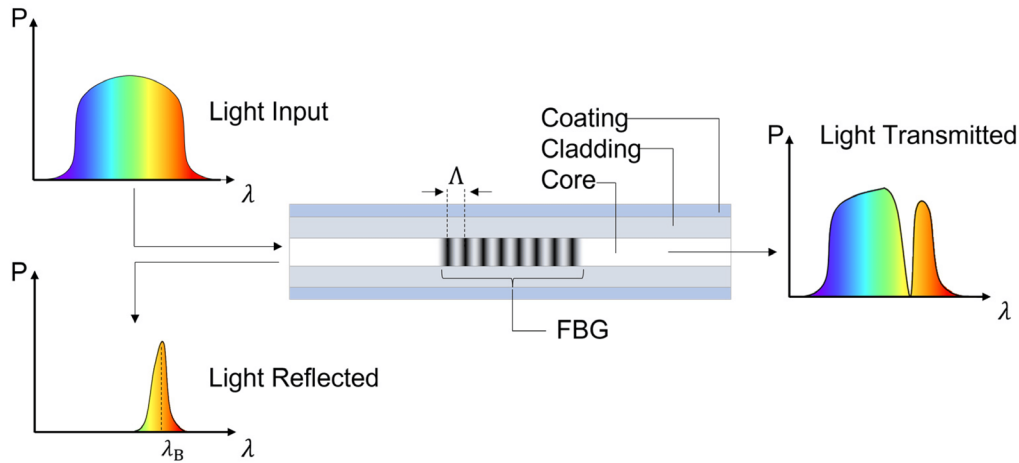

*Figure 1 – An illustration of FBG working principle. When the light signal is transmitted through the fiber, a part of it, associated with the Bragg wavelength  $\lambda_B$ , is reflected back towards the source. The image was taken from [1].*

The research project discussed in this paper is related to the use of optical sensors for an aerospace application. It was born as an internal collaboration at the PhotoNext Interdepartmental Center, a hub for applied optics of the Politecnico di Torino created in the summer of 2017 as a cornerstone of its strategic research initiatives. In detail, it involves the Department of Control and Computer Engineering (DAUIN) and the Department of Mechanical and Aerospace Engineering (DIMEAS) in the creation of a flying test bench to experiment with the use of FBG sensors in the aerospace sector and monitor the related values remotely [12-15]. The flying test bench, whose operating diagram is shown in Fig. 2, mainly consists of a UAV called Anubi. It was constructed in 2017 by the ICARUS student team of the Politecnico di Torino to participate in the Air Cargo Challenge (ACC) 2017, an important biennial European student competition for the field of aeronautical engineering. FBG sensors have been strategically placed on the wing, fuselage, and tail of the Anubi UAV to monitor its structure in real-time while in flight, providing valuable data for structural integrity assessment. The measured values can be read using an optical interrogator, to which the FBG sensors themselves must be connected. In the specific case in question, the optical interrogator used is the SmartScan produced by Smart Fibres Ltd. The remote monitoring operation can be made through a dedicated software application chain, which allows reading, transmitting, storing, and displaying the FBG sensor values directly on the ground via Personal Computers (PC). The Middleware represents the first element in this chain, an application written in C/C++ made to run directly on a Raspberry Pi mounted on the UAV itself and connected to the SmartScan via Ethernet. It is responsible for reading the data coming from the optical interrogator and sending it to a NoSQL Cloud Database based on MongoDB. One of the key advantages of NoSQL databases, which store data differently than relational tables, is that they are designed to provide fast read and write operations, making them suitable for use cases that require low latency and real-time data processing. Among the features of MongoDB is Change Stream, a real-time data update notification feature that allows applications that interface with the database to respond instantly to data changes. The last element of the chain is represented by the Viewers, whose primary purpose is to guarantee a simple and intuitive vision of the sensory data by researchers working on the type of optical sensors under examination. At the moment, there are two different Viewers, which allows the intuitive displaying of sensory data directly on the ground.

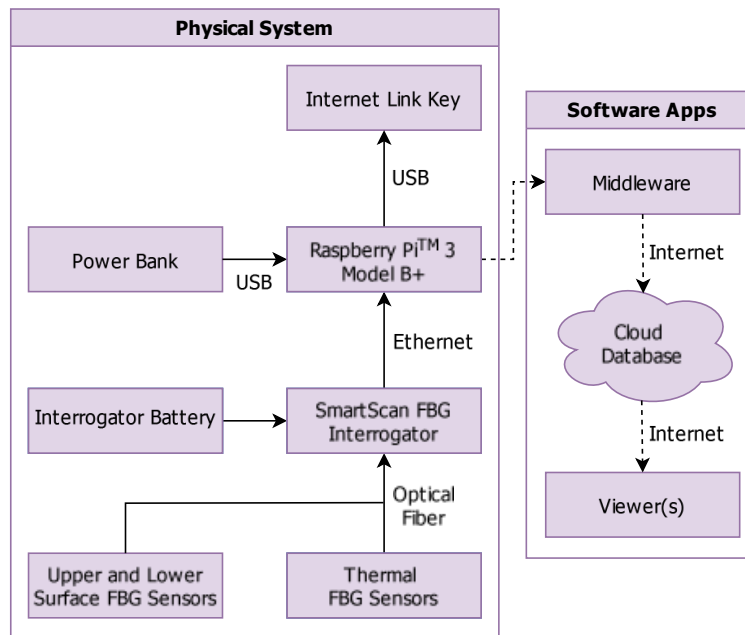

Figure 2 – A diagram depicting the operation of the flying test bench.

The PhotoNext 3D Viewer, realized with Unity, allows to display data in two ways [12]:

- A 3D heat map view offers a qualitative depiction of sensor values directly on a 3D model of the UAV. This is done by adjusting the color gradients of the 3D model near the area where each sensor is located.
- A graphical view shows the fluctuation of sensor values from their baseline.

PhotoNext FBG Data Analyzer was created without an actual game engine to make it more performant [15]. It has, therefore, lost the ability to view data via 3D heat map, but it is rich in multiple features and views, including tabular visualization of individual values, that are not present in PhotoNext 3D Viewer.

## Conclusions

This paper discusses the current state of implementation of the flying test bench. Its purposes are multiple: to test the use of FBG sensors for the aerospace sector and to implement a remote monitoring system. So far, three flight test campaigns have been successfully conducted at the Tetti Neirotti runway, near Turin, to test both new FBG sensors and new applications. A new flight campaign is currently planned to test novel sensors.

## Funding

This work was carried out under the PhotoNext initiative at Politecnico di Torino (<http://www.photonext.polito.it/>).

## References

- [1] F. Falcetelli, A. Martini, R. Di Sante, and M. Troncossi, Strain Modal Testing with Fiber Bragg Gratings for Automotive Applications, *Sensors* 22(3) (2022), 946. <https://doi.org/10.3390/s22030946>
- [2] C.-Y. Hong, Y.-F. Zhang, M.-X. Zhang, L. M. G. Leung, and L.-Q. Liu, Application of FBG Sensors for Geotechnical Health Monitoring, a Review of Sensor Design, Implementation Methods and Packaging Techniques, *Sensors and Actuators A: Physical*, 244 (2016), 184-197, <https://doi.org/10.1016/j.sna.2016.04.033>.

- [3] M. A. Riza, Y. I. Go, S. W. Harun, and R. R. J. Maier, "FBG Sensors for Environmental and Biochemical Applications—A Review," *IEEE Sensors Journal* 20(14) (2020), 7614-7627. <https://doi.org/10.1109/JSEN.2020.2982446>
- [4] J. Leng and A. Asundi, Structural Health Monitoring of Smart Composite Materials by Using EFPI and FBG Sensors, *Sensors and Actuators A: Physical*, 103(3) (2003), 330-340. [https://doi.org/10.1016/S0924-4247\(02\)00429-6](https://doi.org/10.1016/S0924-4247(02)00429-6)
- [5] C. Rodrigues, C. Félix, A. Lage, and J. Figueiras, Development of a Long-Term Monitoring System based on FBG Sensors Applied to Concrete Bridges, *Engineering Structures* 32(8) (2010), 1993-2002. <https://doi.org/10.1016/j.engstruct.2010.02.033>
- [6] M. Mieloszyk and W. Ostachowicz, An application of Structural Health Monitoring system based on FBG sensors to offshore wind turbine support structure model, *Marine Structures* 51 (2017), 65-86. <https://doi.org/10.1016/j.marstruc.2016.10.006>
- [7] X. Qiao, Z. Shao, W. Bao, and Q. Rong, Fiber Bragg Grating Sensors for the Oil Industry, *Sensors* 17(3) (2017), 429. <https://doi.org/10.3390/s17030429>
- [8] O. De La Torre, I. Floris, S. Sales, and X. Escaler, Fiber Bragg Grating Sensors for Underwater Vibration Measurement: Potential Hydropower Applications, *Sensors* 21(13) (2021), 4272. <https://doi.org/10.3390/s21134272>
- [9] A. Aimasso, C. G. Ferro, M. Bertone, M. D. L. Dalla Vedova, and P. Maggiore, Fiber Bragg Grating Sensor Networks Enhance the In Situ Real-Time Monitoring Capabilities of MLI Thermal Blankets for Space Applications, *Micromachines* 14(5) (2023), 926. <https://doi.org/10.3390/mi14050926>
- [10] A. Aimasso, Optical fiber sensor fusion for aerospace systems lifecycle management, *Materials Research Proceedings* 33 (2023), 288-293. <https://doi.org/10.21741/9781644902677-42>
- [11] A. Aimasso, G. Charruaz, M. Bertone, C. G. Ferro, M. D. L. Dalla Vedova, and P. Maggiore, Test Bench and Control Logic Development for Dynamic Thermal Characterization of Optical Sensors, *International Journal of Mechanics and Control* 24 (2023).
- [12] A. C. Marceddu, G. Quattrocchi, A. Aimasso, E. Giusto, L. Baldo, M. G. Vakili, M. D. L. Dalla Vedova, B. Montrucchio, and P. Maggiore, Air-to-Ground Transmission and Near Real-Time Visualization of FBG Sensor Data via Cloud Database, *IEEE Sensors Journal* 23(2) (2023), 1613-1622. <https://doi.org/10.1109/JSEN.2022.3227463>
- [13] A. C. Marceddu, A. Aimasso, A. Scaldaferrì, P. Maggiore, B. Montrucchio, and M. D. L. Dalla Vedova, Creation of a Support Software for the Development of a System for Sending and Visualizing FBG Sensor Data for Aerospace Application, *2023 IEEE 10th International Workshop on Metrology for AeroSpace (MetroAeroSpace)* (2023) 487-491. <https://doi.org/10.1109/MetroAeroSpace57412.2023.10190008>
- [14] A. C. Marceddu and B. Montrucchio, Storage and visualization on-the-ground and in near real-time of the data measured by the optical sensors connected to a flying test bench, *Materials Research Proceedings* 33 (2023), 277-280.
- [15] A. C. Marceddu, A. Aimasso, S. Schiavello, B. Montrucchio, P. Maggiore, M. D. L. Dalla Vedova, Comprehensive Visualization of Data Generated by Fiber Bragg Grating Sensors in *IEEE Access* 11 (2023). doi: <https://doi.org/10.1109/ACCESS.2023.3329425>