

Direct Measurement of Laser Noise Spectrum with a Frequency-to-Voltage Converter

*Original*

Direct Measurement of Laser Noise Spectrum with a Frequency-to-Voltage Converter / Antona, G.; Costanzo, G. A.; Gozzelino, M.; Micalizio, S.; Calosso, C. E.; Levi, F.. - ELETTRONICO. - (2022). (Intervento presentato al convegno Joint Conference of the European Frequency and Time Forum and IEEE International Frequency Control Symposium (EFTF/IFCS) tenutosi a Paris (France) nel 24-28 April 2022) [10.1109/efft/ifcs54560.2022.9850473].

*Availability:*

This version is available at: 11583/2987227 since: 2024-03-27T16:55:43Z

*Publisher:*

IEEE

*Published*

DOI:10.1109/efft/ifcs54560.2022.9850473

*Terms of use:*

This article is made available under terms and conditions as specified in the corresponding bibliographic description in the repository

*Publisher copyright*

IEEE postprint/Author's Accepted Manuscript

©2022 IEEE. Personal use of this material is permitted. Permission from IEEE must be obtained for all other uses, in any current or future media, including reprinting/republishing this material for advertising or promotional purposes, creating new collecting works, for resale or lists, or reuse of any copyrighted component of this work in other works.

(Article begins on next page)

# Direct measurement of laser noise spectrum with a frequency-to-voltage converter

G. Antona, G. A. Costanzo  
Electronics and Telecommunications Department  
Politecnico di Torino  
Torino, Italy  
gaspare.antona@studenti.polito.it

M. Gozzelino, S. Micalizio, C. E. Calosso, F. Levi  
Quantum Metrology and Nanotechnologies Division  
INRIM - Istituto Nazionale di Ricerca Metrologica  
Torino, Italy  
m.gozzelino@inrim.it

**Summary**— The stability performance of laser-pumped Rb-cell atomic clocks is affected by the laser spectral characteristics. It is then important to investigate the laser spectrum, especially since laser noise measurements are rarely found in the literature. We present a frequency-noise power spectrum characterization of a laser diode currently employed in a high-performing Rb clock. The measurement is performed by using a narrow-linewidth reference laser. The beatnote between the two sources is processed with a custom frequency-to-voltage (f/V) converter whose output is finally digitized with an FFT spectrum analyzer.

**Keywords**— laser; frequency noise; frequency-to-voltage converter; rubidium; atomic clocks.

## I. INTRODUCTION

Technological sectors such as aerospace, global navigation satellite systems, telecommunication, and defense require very stable atomic oscillators for timekeeping. Compact atomic clocks based on Rb are currently employed as frequency references and they provide the required stability and uncertainty. In the current scenario of atomic frequency standards, vapor-cell clocks [1] based on alkaline atoms pumped by a laser are suited for those activities that demand good frequency stability performances. The laser noise is transferred to the clock signal through the interaction with the atomic medium and represents one of the main factors limiting the clock stability [1],[2]. Thus, the laser spectral behavior becomes crucial to be investigated, also because frequency noise measurements are rarely found in the literature for diode lasers at 780 nm [3],[4].

In this work, we characterize the frequency noise of a DFB laser diode employed in a Rb clock experiment [1]. The measurement is based on the beatnote signal between the device under test and a narrow-linewidth frequency-doubled telecom laser [5]. The phase noise of the DFB laser is too high to be characterized by high-performance commercial phase meters, usually designed to measure low-noise radio-frequency (RF) oscillators. Therefore, at INRIM, we developed a dedicated frequency-to-voltage (f/V) converter to allow direct measurement of the beatnote frequency noise.

## II. METHODS

The proposed method involves the analysis of the optical beatnote generated between the laser under test and a reference laser. The beatnote signal is proportional to the frequency difference between the two lasers, thus its analysis enables the measurement of the sum of the frequency noises of the two lasers in the radio-frequency domain. Assuming the reference laser to have negligible frequency noise, in the Fourier-frequency region of interest, we can attribute all the measured noise to the device under test. This will be checked later.

The reference is a low-noise Koheras Adjustik (NKT Photonics), co-doped Erbium/Ytterbium fiber laser at 1560 nm. The source is amplified by a fiber amplifier (Koheras Boostik) and a frequency-doubled to be resonant with the Rb D2 line at 780.241 nm. The DFB laser under test and the reference laser are superimposed, with the same polarization and power level on a dedicated optical bench, represented in Fig. 1.

Fig. 2 shows the measurement scheme of the beatnote generation. The beatnote between the two lasers is set within the working range of the f/V converter (<150 MHz) and it is acquired by a fast photodiode (250 MHz bandwidth). The sinusoidal photodiode signal is sent to the f/V converter. This device outputs a DC voltage proportional to the input frequency. A Fast Fourier Transform (FFT) spectrum analyzer (SA) is used to obtain the power spectral density (PSD) of the DC voltage. Finally, the voltage PSD is converted into the laser frequency noise simply by knowing the frequency-to-voltage sensitivity of the converter.

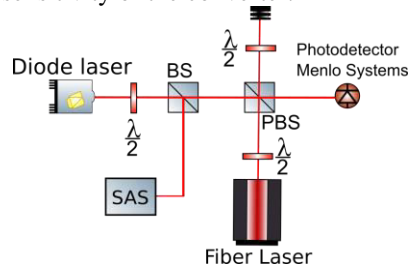

Fig. 1: Laser setup for beatnote generation. The optics are used to overlap the beams, to have the same laser beam's polarization and power. The saturated absorption spectroscopy setup (SAS) is used to stabilize the laser system to an external cell.

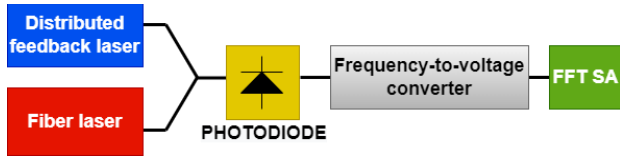

Fig. 2: Measurement scheme. The beatnote is generated between the two lasers and detected by the photodiode. The RF beatnote is converted into the DC voltage, and a Fast Fourier Transform spectrum analyzer (FFT SA) is used to obtain the power spectral density of the laser frequency noise.

Since the device under test is a free-running diode laser, its phase noise is orders of magnitude larger than low-noise RF oscillators, due to the huge leverage between the optical and RF domain. Usual laboratory phase meters are thus not suitable to measure the frequency noise of the beatnote. To overcome this limitation, the beatnote frequency noise is measured using a custom frequency-to-voltage converter, whose scheme is shown in Fig. 3. The device converts the beatnote signal into a DC voltage. The voltage noise can finally be digitized, and its Fourier spectrum derived.

The f/V converter transforms the input RF signal into a train of pulses a fixed area whose repetition rate is the same as the input frequency. The device is configured as a Complex Programmable Logic Device (CPLD), based on a D-latch and NAND logic port. As reported in Fig. 3, at every zero crosses, this device transforms the input signal into a pulse of a fixed area. The pulse has a constant amplitude, and the duration is set by the self-resetting mechanism. At last, the result is a train of pulses with the same frequency as the input sinusoid. The series of impulses arrive at an analogical low-pass filter, with a cutoff frequency of 1 MHz, that averages the standard pulses and produces an output voltage proportional to the input frequency [6], [7].

The frequency-to-voltage converted is powered by a single 5 V supply, followed by a voltage regulator, to maximize the power supply rejection ratio. The device accepts measured sinusoidal inputs from -6 dBm to 15 dBm. It has a wide input frequency range by design (from 1 MHz to 200 MHz) and an acceptable output voltage (from 0 V to 3.3 V). To have precise noise measurements the f/V converter is calibrated, and its residual noise is measured to understand the impact on the laser frequency-noise measurement [8].

A synthesizer is used as input to give a frequency sweep at different input powers, to have a complete characterization of the device under test. The calibration curve is retrieved by performing a least-square method.

The device behavior was found to be linear in the limited range of 10 MHz to 160 MHz. Within this range, the device can be characterized by a single sensitivity coefficient that turns out to be  $a = 5.4$  (1) mV/MHz.

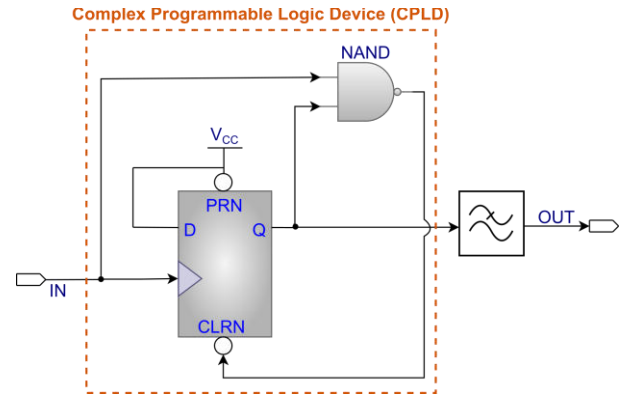

Fig. 3: f/V converter scheme. Commercial Programmable Logic Device (CPLD) implemented using a NAND and a D-latch. The insets show the voltage signals at significant points of the circuit.

We characterize the instrument noise as a function of the input frequency and we found that the noise level, measured at different carrier frequencies from 10 MHz to 160 MHz in octaves is proportional to the input frequency. The voltage power spectral density values  $S_V(f)$  obtained before are converted into frequency  $S_v(f)$ , using the calibration coefficient found before.

$$S_v(f) = \frac{1}{a^2} S_V(f)$$

The device has a flicker behavior, increasing about 6 dB/Oct with the carrier frequency.

To define better what class of lasers can be characterized within the f/V converter, the measured instrument noise is converted in terms of a contribution to the beatnote linewidth. Thus, the linewidths of the spectra are measured using the  $\beta$ -line method [9].

$$\beta(f) = 8 \ln 2 \frac{f}{\pi^2}$$

The contribution to the beatnote linewidth is less or equal to 10 kHz at all carriers. So, the frequency-to-voltage converter is suitable for lasers having a linewidth as low as 10 kHz.

### III. DISCUSSION

The frequency noise is measured with the fiber laser free-running and with the laser diode in two conditions: stabilized on a reference Rb cell or free-running. The measured noise spectrum has roughly a flicker-frequency slope ( $f^{-1}$ ) as reported in Fig. 4 when both the DFB and the fiber laser are free-running. With the DFB stabilized, the low-frequency noise is reduced as expected, at low Fourier frequencies. While for Fourier frequencies above the locking bandwidth (50 Hz), the two spectra match.

From the  $\beta$ -line method [9] we derived a linewidth of the laser diode of about 2 MHz, much larger than the reference, which is on the order of 50 kHz from the test report [10].

The instability of Rb clocks [11] is related to the noise spectrum at multiples of the clock cycle frequency ( $f_c = 1/T_c = 100$  Hz). So, the range [100 Hz  $\div$  some kHz] is correctly measured within instrument capabilities. It is suitable to characterize the laser diodes for atomic clocks. So, we can observe in Fig. 4 that the diode laser noise spectrum at 100 Hz is equal to 80 dB Hz<sup>2</sup>/Hz, where there is a plateau.

The f/V converter residual noise and the fiber laser noise contribution taken from the test report at least 20 dB below the distributed feedback laser frequency noise are also represented in Fig. 4, and there are negligible for the measured frequency noise. The black and the violet curves are representative only of the DFB and fiber laser measurements.

As a further characterization, the current driver contribution to the laser performances is analyzed. We characterized independently the laser driver used in the experimental setup as current noise, then converted it into frequency noise, as the red curve in Fig. 5 using the diode current-to-frequency sensitivity coefficient [8]. From this analysis, it is found that the current driver noise contribution is not negligible limiting the performances of the diode laser, for Fourier frequencies above 500 Hz.

Finally, the intrinsic noise of the diode laser is evaluated as the subtraction between the beatnote frequency noise and the current driver noise, as reported in Fig. 6.

$$S_{v,intrinsic} = S_v - S_{v,current\ driver}$$

The laser diode intrinsic noise is almost flicker of frequency ( $f^{-1}$ ) for two decades, from 10 Hz to 1 kHz [8]. A laser driver with a lower frequency noise contribution can be used to improve the diode laser performance and to obtain a better measurement of the intrinsic laser frequency noise.

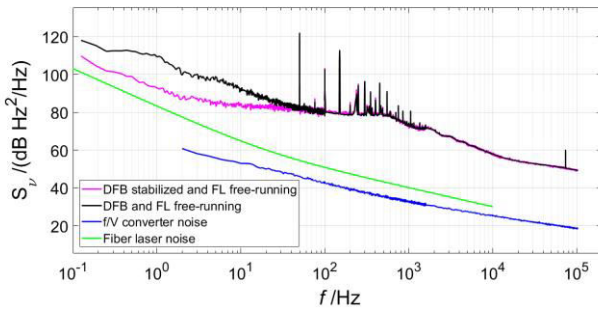

Fig. 4: Beatnote frequency noise with fiber laser free-running and DFB in two conditions. The f/V converter contribution in blue and the fiber laser noise taken from the test report in green are about 20 dB below the laser diode frequency noise.

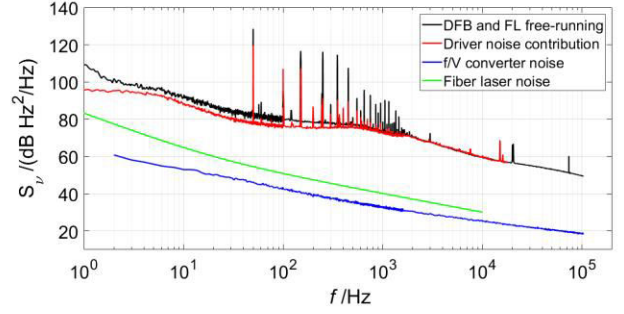

Fig. 5: Beatnote frequency noise with fiber laser and diode laser both in free-running, in the black curve. Driver noise contribution in red and how it impacts the measurement. From these two curves can be evaluated the intrinsic noise. Also, the two negligible f/V and fiber laser contributions are represented.

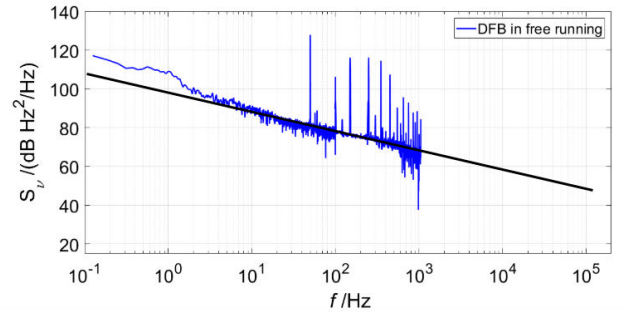

Fig. 6: Laser diode intrinsic noise is measured as the subtraction of the beatnote and the current driver frequency noise. It is almost a flicker of frequency from 10 Hz to 1 kHz.

#### IV. CONCLUSIONS

In conclusion, we report the frequency noise characterization of a commercial DFB laser. The measurement is obtained by performing a beatnote with a reference laser.

The intrinsic diode laser is estimated by subtracting the noise contribution coming from the current driver. A better measurement of the intrinsic laser frequency noise can be obtained using current drivers with lower frequency noise contribution.

The frequency noise is converted into voltage noise through a dedicated fast converter, and then easily measured with an FFT spectrum analyzer. The instability of Rb clocks [11] is related to the noise spectrum at multiples of the clock cycle frequency ( $f_c = 1/T_c = 100$  Hz). This measurement scheme covers the most critical Fourier frequency range [100 Hz  $\div$  10 kHz], thus is suitable to characterize the laser diodes for atomic clocks.

We characterized the f/V converter noise also as a function of the input frequency, and we found that the noise level is proportional to the input frequency. Therefore, it is suitable for characterizing diode lasers with a linewidth as low as 10 kHz.

The proposed measurement setup can be generalized for synchronously measuring multiple sources. This solution is also suitable for measuring the laser frequency noise without having a lower-noise source as a reference, taking benefit from the cross-correlation technique [12].

#### V. ACKNOWLEDGMENTS

We would like to thank Elio Bertacco for his help in developing and testing the frequency-to-voltage converter.

#### REFERENCES

- [1] S. Micalizio, F. Levi, C.E. Calosso, M. Gozzelino and A. Godone, "A pulsed-Laser Rb atomic frequency standard for GNSS applications". Springer, vol. 25, no. 3, pp. 1-13, 2021.
- [2] N. Almat, M. Pellaton, W. Moreno, F. Gruet, C. Affolderbach and G. Mileti. "Rb vapor-cell clock demonstration with a frequency-doubled telecom laser ", Opt. Soc. of America, vol. 57, no.16, pp. 4707-4713, 2018.
- [3] C. Affolderbach, and G. Mileti, "A compact laser head with high-frequency stability for Rb atomic clocks and optical instrumentation". Rev. of Sc. Instr., vol. 76, no. 7, 2005.
- [4] O. Llopis, G. Bailly, A. Bougaud, and A. Fernandez. "Experimental investigations on lasers FM and AM noise", Joint Conference of the IEEE International Frequency Control Symposium and International Symposium on Applications of Ferroelectrics (IFCS-ISAF), 2020.
- [5] M. Schiemangk, S. Spießberger, A. Wicht, G. Erbert, G. Tränkle, and A. Peters, "Accurate frequency noise measurement of free-running lasers". Appl. Opt., vol. 53, n. 30, pp. 7138-7143, 2014.
- [6] D. Cohen, I. Tiroshi, and S. Eylon, "High-Speed Frequency-to-Voltage Converter with 0.01-Percent Accuracy". IEEE Trans. on Instr. and Meas., vol. 22, n. 2, pp. 108-113, 1973.
- [7] L. Yan, Y. Zhang, Z. Tai, P. Zhang, R. Yuan, S. Zhang, and H. Jiang, "Frequency to voltage converter with ultra-low residual frequency noise", Conference on Lasers and Electro-Optics/Pacific Rim, 2018.
- [8] G. Antona, "Laser frequency characterization for new generation atomic clocks", Master's Thesis, Politecnico di Torino, 2021.
- [9] G. Di Domenico, S. Schilt, and P. Thomann, "Simple approach to the relation between laser frequency noise and laser line shape", App. Opt., vol. 49, n. 25, pp. 4801-4807, Opt. Soc. of America, 2010.
- [10] NKT Photonics, "Bootstik HPA Users Manual", Sep 2016.
- [11] S. Micalizio, C. E. Calosso, A. Godone, and F. Levi, "Metrological characterization of the pulsed Rb clock with optical detection". Metrologia, vol. 49, no. 4, pp. 425-436, May 2012.
- [12] F. Vernotte, C.E. Calosso, E. Rubiola, "Three-cornered hat versus Allan covariance", IEEE Int. Freq. Control Symposium (IFCS), pp. 1-6, 2016.