

Power Decoupling Method for Grid Inertial Support Provided by Ultra-Fast Bidirectional Chargers

Original

Power Decoupling Method for Grid Inertial Support Provided by Ultra-Fast Bidirectional Chargers / Roveri, Alessandro; Mallemaci, Vincenzo; Mandrile, Fabio; Bojoi, Radu. - ELETTRONICO. - (2023), pp. 6544-6546. (Intervento presentato al convegno 2023 IEEE Energy Conversion Congress and Exposition (ECCE) tenutosi a Nashville, TN, USA nel 29 October 2023 - 02 November 2023) [10.1109/ECCE53617.2023.10362280].

Availability:

This version is available at: 11583/2984952 since: 2024-01-10T17:41:59Z

Publisher:

IEEE

Published

DOI:10.1109/ECCE53617.2023.10362280

Terms of use:

This article is made available under terms and conditions as specified in the corresponding bibliographic description in the repository

Publisher copyright

IEEE postprint/Author's Accepted Manuscript

©2023 IEEE. Personal use of this material is permitted. Permission from IEEE must be obtained for all other uses, in any current or future media, including reprinting/republishing this material for advertising or promotional purposes, creating new collecting works, for resale or lists, or reuse of any copyrighted component of this work in other works.

(Article begins on next page)

Power Decoupling Method for Grid Inertial Support Provided by Ultra-Fast Bidirectional Chargers

Alessandro Roveri
Prima Electro S.p.A.
Moncalieri (TO), Italy

alessandro.roveri@primaelectro.com

Vincenzo Mallemaci
Dipartimento Energia
Politecnico di Torino, Italy

vincenzo.mallemaci@polito.it

Fabio Mandrile
Dipartimento Energia
Politecnico di Torino, Italy

fabio.mandrile@polito.it

Radu Bojoi
Dipartimento Energia
Politecnico di Torino, Italy

radu.bojoi@polito.it

Abstract—The Active Front-End (AFE) converter unit of ultra-fast battery chargers can contribute to the inertial frequency response by embedding the Virtual Synchronous Machine (VSM) control algorithm. However, the injection of inertial active power involves a non-negligible reactive power contribution due to the active-reactive power coupling, thus increasing the current output of the converter. Therefore, this paper proposes an active-reactive power decoupling solution to minimize the AFE current rating for frequency support.

Keywords—grid support, ultra-fast chargers, power decoupling

I. INTRODUCTION

The widespread penetration of bidirectional ultra-fast charging infrastructures opens up the possibility to make grid-connected battery chargers able to provide ancillary services (i.e., inertial behaviour and grid support during faults [1-3]). Recent papers [3] demonstrated that a charging station can fulfil both the charging process and the provision of grid services by integrating the Virtual Synchronous Machine (VSM) algorithm into the bidirectional Active Front End (AFE) control. In case of grid frequency variation, the AFE can inject/absorb active power by emulating the inertial behaviour of Synchronous Generators (SGs), thus limiting the grid frequency deviation. The charging operation is the main functionality of the infrastructure, while the inertial support is an add-on feature, which should impact as little as possible on the hardware design. However, it is well known [4] that VSMs feature a coupling between active and reactive power. This undesired effect means that a larger amount of current is needed when providing the inertial support. Therefore, the implementation of a decoupling solution should be considered to limit the current injection. The power coupling issues are widely discussed in literature for VSM controls [4]. These algorithms assume that the active power depends linearly only on the load angle (P - δ), while the reactive power only depends on the voltage amplitude (Q - V). This assumption is based on a purely inductive transmission line and a small load angle. However, in many cases (e.g., low voltage networks and microgrids) the grid and VSM resistances and the load angle are not negligible. Consequently, the active and reactive power are coupled (i.e., when the active power varies, the reactive power changes as well) [4]. The main consequences are the dynamic performance degradation, the risk of system instability and the capability reduction in providing the grid support [5]. Many power decoupling algorithms are available in literature. The virtual impedance method [6,7] is widely used. However, its decoupling capability is limited, as demonstrated in [8]. Furthermore, this method guarantees the decoupling only at steady-state, as also happens for the virtual power [9] and

feedforward based [10,11] solutions. Moreover, such methods only compensate for the coupling due to the line resistance. More recent papers focused on the dynamic decoupling [12-14]. However, the power coupling issue was only investigated with the goal of the dynamic response and the stability of the converters, while the effects on the provision of the ancillary services were not discussed. Motivated by the limits of the above mentioned methods, this paper proposes a straightforward decoupling solution, based on the implementation of two feedforward terms in the excitation control loop of the VSM model employed for the AFE unit of bi-directional chargers. Such solution guarantees the complete active-reactive power dynamic decoupling and reduces the needed amount of current to ensure the inertial support. Thanks to the proposed method, the stress on the AFE for the grid support is minimized and a larger amount of the rated current can be used for the charging process. This paper is organized as follows. Section II provides a physical description of the power coupling mechanism and the proposed decoupling method. Section III is dedicated to the experimental results and the validation of the solution in performing the decoupling during the inertial support. Section IV concludes the paper.

II. PROPOSED DECOUPLING METHOD

The adopted VSM solution is the S-VSC control algorithm proposed in [15], whose control scheme in per unit is reported in Fig. 1. In this model, the measured voltage v_c is aligned to the q-axis. Therefore, the active power depends on the $i_{v,q}$ current component (i.e., $P_v \approx v_{c,q} i_{v,q}$), while the reactive power on $i_{v,d}$ (i.e., $Q_v \approx v_{c,d} i_{v,d}$). The injection of $i_{v,d}$ during the inertial support is caused by a voltage drop on the total equivalent inductance of the system in q-axis, as shown in (1)-(2):

$$\Delta v_{l,q} = \Delta \omega_r \lambda_e - (R_g + R_v) \Delta i_{v,q} \quad (1)$$

$$\Delta i_{v,d} = \frac{\Delta v_{l,q}}{\omega_r (L_g + L_v)} \quad (2)$$

where $\Delta v_{l,q}$ is the inductance q-axis voltage drop, ω_r the virtual rotor speed, λ_e the excitation flux, R_g , L_g , R_v and L_v the resistive and inductive elements of the grid and the VSM.

From (1) two terms can be derived. These terms are added as a feedforward to the excitation control loop as highlighted in red in Fig. 1. They compensate for the inductance voltage drop, thus limiting $i_{v,d}$ and consequently the reactive power injection. The term λ_{ω} compensates for the voltage drop due to the speed variation with respect to the nominal value ω_n and consequently

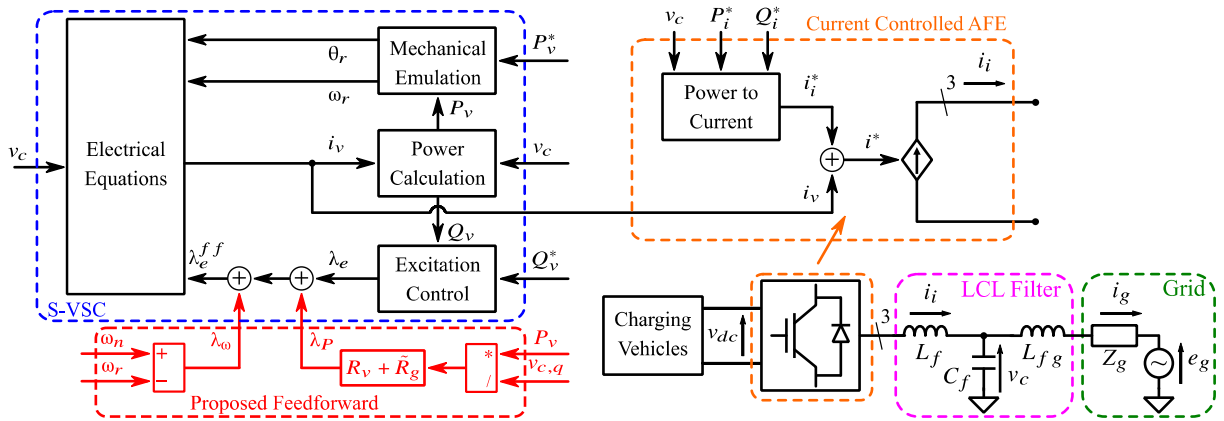

Fig. 1. Control scheme of the VSM with the proposed feedforward power decoupling method.

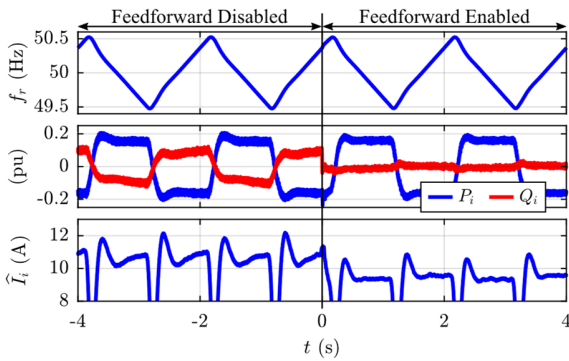

Fig. 2. Results of Test 1. From top to bottom: virtual frequency, active and reactive power, peak phase current of grid inverter.

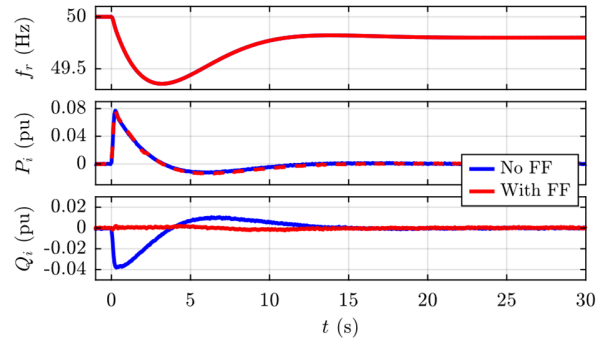

Fig. 3. Results of Test 2. From top to bottom: virtual frequency, active power and reactive power.

to the load angle deviation. Instead, the term λ_p limits the power coupling due to the total system resistance.

III. EXPERIMENTAL RESULTS

The proposed feedforward decoupling method has been experimentally validated on a 15 kVA two-level three-phase inverter controlled by a dSPACE 1005 platform with 10kHz of switching/sampling frequency. The inverter is connected through an LCL filter ($L_f = 545 \mu\text{H}$, $C_f = 22 \mu\text{F}$ and $L_{fg} = 120 \mu\text{H}$) to a 50 kVA grid emulator able to provide a 50 Hz 120 V_{rms} phase voltage. A three-phase inductor ($L_g = 270 \mu\text{H}$) is placed between the power converter and the grid emulator as grid impedance. The measured equivalent resistance of the grid is $R_g = 115 \text{ m}\Omega$. A constant DC source supplies the inverter. The main parameters of the VSM are: virtual inductance $L_v = 0.1 \text{ pu}$, virtual resistance $R_v = 0.02 \text{ pu}$, inertia constant $H = 4 \text{ s}$, excitation control time constant $\tau_e = 1 \text{ s}$ [15]. Two different tests have been performed to evaluate the effects of the proposed decoupling method during the inertial support. In Test 1 (Fig. 2) the grid frequency varies triangularly in the range 49.5-50.5 Hz with a period of 2 s. Initially, the power decoupling is not performed and a maximum reactive power of 0.1 pu is provided. This reactive power is not required to the inertial support and the inverter is overstressed. Then, at time $t = 0 \text{ s}$, the feedforward terms are enabled and the reactive power injection is almost cancelled without affecting the active power injection. Furthermore, the amount of injected current into the grid is

reduced by 10.4%. In Test 2 (Fig. 3) a realistic grid frequency drop due to a large power imbalance is emulated, as in [15]. The test was performed with and without the proposed feedforward decoupling. The obtained results confirm the outcomes of Test 1, i.e. the proposed decoupling method does not affect the inertial behaviour and at the same time allows to limit the reactive power, thus minimizing the injected current to perform the inertial support.

IV. CONCLUSION AND FUTURE WORKS

This paper proposes an active-reactive power decoupling solution for VSM controls to minimize the AFE current stress when providing inertial support. Indeed, it cancels the reactive power injection due to the power coupling. This method results well suitable in ultra-fast charging systems, where the current effort for the grid support has to be minimized and the largest possible power capability has to be used for the charging operation. Experimental results validate the proposed method, confirming that VSM controls implemented in the AFEs of ultra-fast charging systems are a promising solution to guarantee the stability of the electric power system. Therefore, further studies regarding the power coupling for these applications are expected. Future works will focus on studying the coupling in case of voltage dips and swells, when the AFE should only inject reactive current. Moreover, future works will also include the sensitivity of the proposed feedforward method to the grid resistance estimation.

REFERENCES

- [1] J.A. Suul, S. D'Arco, and G. Guidi, "Virtual Synchronous Machine-Based Control of a Single-Phase Bi-Directional Battery Charger for Providing Vehicle-to-Grid Services," *IEEE Trans. Ind. Appl.*, vol. 52, no. 4, pp. 3234–3244, Jul.-Aug. 2016.
- [2] M. Kesler, M.C. Kisacikoglu, and L.M. Tolbert, "Vehicle-to-Grid Reactive Power Operation Using Plug-In Electric Vehicle Bidirectional Offboard Charger," *IEEE Trans. Ind. Electron.*, vol. 61, no. 12, pp. 6778–6784, Dec. 2014.
- [3] F. Mandrile, D. Cittanti, V. Mallemaci, and R. Bojoi, "Electric vehicle ultra-fast battery chargers: a boost for power system stability?" *World Electr. Veh. J.* 2021, 12, 16.
- [4] M. Li, Y. Wang, W. Hu, S. Shu, P. Yu, Z. Zhang, and F. Blaabjerg, "Unified modeling and analysis of dynamic power coupling for grid-forming converters," *IEEE Trans. Power Electron.*, vol. 37, no. 2, pp. 2321–2337, Feb. 2022.
- [5] D. Yang, X. Wang, F. Liu, K. Xin, Y. Liu, and F. Blaabjerg, "Adaptive reactive power control of PV power plants for improved power transfer capability under ultra-weak grid conditions," *IEEE Trans. Smart Grid*, vol. 10, no. 2, pp. 1269–1279, Mar. 2019.
- [6] J. M. Guerrero, L. Garcia De Vicuna, J. Matas, M. Castilla, and J. Miret, "Output impedance design of parallel-connected UPS inverters with wireless load-sharing control," *IEEE Trans. Ind. Electron.*, vol. 52, no. 4, pp. 1126–1135, Aug. 2005.
- [7] H. Mahmood, D. Michaelson, and J. Jiang, "Accurate reactive power sharing in an islanded Microgrid using adaptive virtual impedances," *IEEE Trans. Power Electron.*, vol. 30, no. 3, pp. 1605–1617, Mar. 2015.
- [8] T. Wen, D. Zhu, X. Zou, B. Jiang, L. Peng, and Y. Kang, "Power coupling mechanism analysis and improved decoupling control for virtual synchronous generator," *IEEE Trans. Power Electron.*, vol. 36, no. 3, pp. 3028–3041, Mar. 2021.
- [9] J. Rocabert, A. Luna, F. Blaabjerg, and P. Rodriguez, "Control of power converters in AC microgrids," *IEEE Trans. Power Electron.*, vol. 27, no. 11, pp. 4734–4749, Nov. 2012.
- [10] X. Yan, and Y. Zhang, "Power coupling analysis of inverters based on relative gain method and decoupling control based on feedforward compensation," in *Proc. Int. Conf. Renewable Power Gener.*, pp. 1–5, Oct. 2015.
- [11] T. Wen, X. Zou, X. Guo, D. Zhu, L. Peng, and X. Wang, "Feedforward compensation control for virtual synchronous generator to improve power decoupling capability," in *Proc. 14th IEEE Conf. Ind. Electron. Appl. (ICIEA)*, pp. 2528–2533, Jun. 2019.
- [12] B. Li, L. Zhou, X. Yu, C. Zheng, and J. Liu, "Improved power decoupling control strategy based on virtual synchronous generator," *IET Power Electron.*, vol. 10, no. 4, pp. 462–470, Mar. 2017.
- [13] A. Liu, J. Liu, and Q. Wu, "Improvement of VSG transient performance based on power feedforward decoupling control," *IET Power Electron.*, vol. 16, no. 20, pp. 4080–4095, Oct. 2022.
- [14] N. Dong, M. Li, X. Chang, W. Zhang, H. Yang and R. Zhao, "Robust power decoupling based on feedforward decoupling and extended state observers for virtual synchronous generator in weak grid," *IEEE J. Emerg. Sel. Topics Power Electron.*, vol. 11, no. 1, pp. 576–587, Feb. 2023.
- [15] F. Mandrile, E. Carpaneto, and R. Bojoi, "Grid-feeding inverter with simplified virtual synchronous compensator providing grid services and grid support," *IEEE Trans. Ind. Appl.*, vol. 57, no. 1, pp. 559–569, Jan./Feb. 2021.