

Application of Advanced Model Reference Adaptive Control for Bidirectional AC-DC Converters

*Original*

Application of Advanced Model Reference Adaptive Control for Bidirectional AC-DC Converters / Qureshi, Muhammad Ahmed; Musumeci, Salvatore; Torelli, Francesco; Reatti, Alberto; Mazza, Andrea; Chicco, Gianfranco. - ELETTRONICO. - (2023), pp. -5. (Intervento presentato al convegno 58th International Universities Power Engineering Conference (UPEC) tenutosi a Dublin (Ireland) nel 30 August 2023 - 1 September 2023) [10.1109/UPEC57427.2023.10294442].

*Availability:*

This version is available at: 11583/2984650 since: 2024-01-09T14:19:14Z

*Publisher:*

IEEE

*Published*

DOI:10.1109/UPEC57427.2023.10294442

*Terms of use:*

This article is made available under terms and conditions as specified in the corresponding bibliographic description in the repository

*Publisher copyright*

IEEE postprint/Author's Accepted Manuscript

©2023 IEEE. Personal use of this material is permitted. Permission from IEEE must be obtained for all other uses, in any current or future media, including reprinting/republishing this material for advertising or promotional purposes, creating new collecting works, for resale or lists, or reuse of any copyrighted component of this work in other works.

(Article begins on next page)

# Application of Advanced Model Reference Adaptive Control for Bidirectional AC-DC Converters

Muhammad Ahmed Qureshi  
*Dip. Energia "Galileo Ferraris"*  
*Politecnico di Torino*  
Torino, Italy  
muhammad.queshi@polito.it

Salvatore Musumeci  
*Dip. Energia "Galileo Ferraris"*  
*Politecnico di Torino*  
Torino, Italy  
salvatore.musumeci@polito.it

Francesco Torelli  
*Dip. Ing. Elettrica e dell'Informazione*  
*Politecnico di Bari*  
Torino, Italy  
francesco.torelli@poliba.it

Alberto Reatti  
*Dip. Ingegneria dell'Informazione*  
*University of Florence*  
Florence, Italy  
alberto.reatti@unifi.it

Andrea Mazza  
*Dip. Energia "Galileo Ferraris"*  
*Politecnico di Torino*  
Torino, Italy  
andrea.mazza@polito.it

Gianfranco Chicco  
*Dip. Energia "Galileo Ferraris"*  
*Politecnico di Torino*  
Torino, Italy  
gianfranco.chicco@polito.it

## Abstract

Bidirectional AC-DC converters are used in many applications such as renewable energy systems, communication systems, and grid connection of electric vehicles. In this paper, a non-linear controller based on the Lyapunov-based model reference adaptive control approach is proposed for single-phase bidirectional AC-DC converters that incorporate active power factor correction circuits. The proposed controller dynamically adjusts the output power according to the grid conditions and user preferences while maintaining a nearly unitary power factor and a constant output DC voltage set as the reference value. The proposed controller also ensures the stability and robustness of the system under various operating conditions and disturbances. The performance of the proposed controller is compared with another Lyapunov-based control proposed in the literature to show that the proposed controller performs at least on par with the other controller in all aspects.

## Index Terms

Power converter, Model reference, Tracking control, Lyapunov theory, Sensitivity theory, Torelli Control Box, AC-DC Converter, Vehicle to Grid

## I. INTRODUCTION

Bidirectional converters are an integral part of many modern-day electronics used in power system applications. They find uses in a multitude of applications, ranging from photovoltaic-based renewable energy systems to the latest grid connection of electric vehicles (EVs). For example, recently EVs have become popular as they are considered beneficial for the environment in many contexts, with various advantages over conventional vehicles, such as lower emissions, lower fuel costs, lower maintenance costs, and higher efficiency. Under the hood, the power transfer system of the EVs consists of bidirectional DC-AC converters and DC-DC converters, among other power electronic components.

The EVs are also able to contribute to the stability and security of the power grid by providing ancillary services through their operation in Vehicle-to-Grid (V2G) mode [1], which enables bidirectional power flow between EVs and the grid. Therefore, EVs can act as distributed energy resources that can supply or absorb power from the grid depending on the grid conditions and user preferences. The energy flow during the two operations is shown in Fig. 1. When the vehicle is charging, the mode of operation is called Grid to Vehicle (G2V) mode, while the vehicle supports the grid from appropriately operating in the V2G mode.

V2G can offer multiple benefits, such as peak shaving, frequency regulation, voltage support, renewable energy integration, and emergency backup [2]. To offer these V2G services, the EVs use bidirectional converters to transfer power from the battery to the grid and vice versa. This bidirectional transfer of the power still faces some technical issues. One important challenge is to overcome the decrease in power quality caused by the non-linear behaviour of the EV chargers. This happens because these converters are prone to drawing non-sinusoidal currents from the grid, which can distort the grid voltage and reduce the power factor. This low power factor then leads to higher losses, higher currents, and lower voltage levels in the grid [3].

A typical V2G system consists of a bidirectional AC-DC power converter and a DC-DC power converter as shown in Fig. 2. The AC-DC converters used in EV chargers, in addition to converting AC power from the grid to DC power for charging the batteries, are also responsible for Power Factor Correction (PFC). Fig. 3 shows a single phase AC-DC power converter usually used in EV chargers. During the charging mode, it acts as a boost rectifier using the controller to maintain the output voltage at the reference value, while the DC-DC converter attached to it operates in buck mode. During the discharging mode,

the DC-DC converter steps up the output voltage of the battery while AC-DC converter acts as an inverter and controls the active and reactive power injected into the grid.

The controller of the PFC circuit plays a crucial role in improving not only the power quality but also the efficiency of the V2G system. Several linear controllers have been proposed in the literature, such as Proportional Integral Derivative (PID) and linear quadratic based controller for regulating the charging and discharging of electric vehicles (EVs) [4], [5]. Although these controllers can perform adequately, they have a limited range of operation that is confined to a small region near the operating point. Additionally, these controllers are not robust against external disturbances and uncertainties. Lyapunov-based controllers have also been proposed in the literature [6]–[8]. The sliding mode controllers proposed offer robustness against uncertainties, however, they suffer from the issue of chattering which results in power losses of the system. An alternative is the use of higher-order sliding mode control techniques but those require the use of additional integrators or derivatives in the control law, which give rise to additional complexity in their practical implementation.

In this paper, a Lyapunov-based model reference adaptive control is applied by using an advanced controller based on the Torelli Control Box (TCB) formulation for a single-phase V2G technology. The system incorporates an active PFC circuit to improve the power quality and efficiency of EV chargers. The TCB methodology has been previously used for the regulation of DC-DC converters [9] and for maximum power point tracking applications in [10]. Its application to bidirectional converters is shown in this paper for the first time. The proposed controller can dynamically adjust the output power of the EV charger according to the grid conditions and user preferences, while maintaining a high power factor. The proposed controller also ensures the stability and robustness of the V2G system under various operating conditions and disturbances.

The rest of this paper is organized as follows. Section II presents the system model and assumptions. Section III describes the design of the proposed controller and its Lyapunov stability analysis. Section IV shows the simulation results and performance evaluation of the proposed controller. Section V concludes the paper and indicates future work.

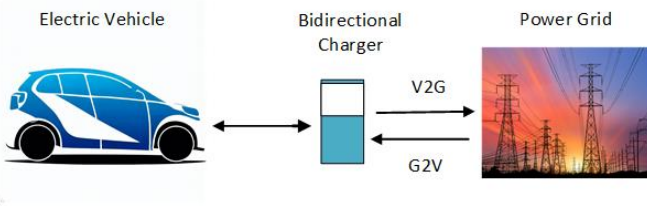

Fig. 1. Energy flow direction during V2G and G2V operating modes

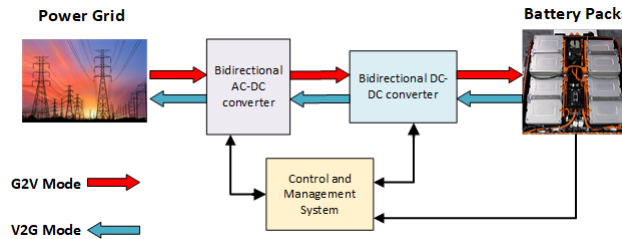

Fig. 2. Block diagram of an Electric Vehicle charger

## II. DERIVATION OF THE AC-DC CONVERTER MODEL

The scheme of the AC-DC converter is shown in Fig. 3. The full-bridge bidirectional AC-DC power converter works by using four switches to control the flow of the current between the input source and the output. When the current flows from the grid to the DC converter output, the converter shown in Fig. 3 acts as a boost rectifier, increasing the output voltage ( $V_{dc}$ ) to be higher than the input source voltage  $E$ . The inductor and capacitor are used to filter the grid current and voltage respectively, to reduce ripples and ensure a smooth and stable output.

### A. System Scheme

The converter, as shown in Fig. 3 has two switching legs. The switches  $S_1$  and  $S_4$  are operated in a complementary way with respect to the switches  $S_2$  and  $S_3$ . The duty cycle  $u$  is used by the pulse width modulation (PWM) circuit to generate the signals as shown in Fig. 4 to operate the switches.

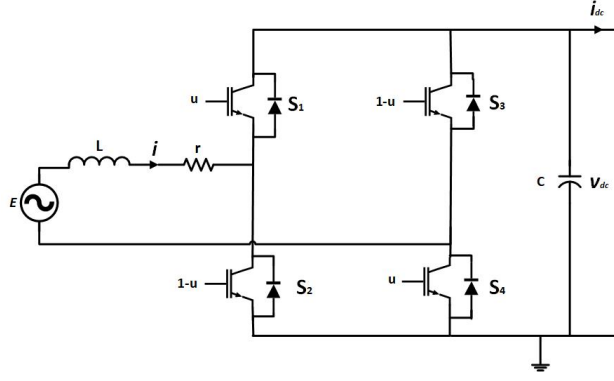

Fig. 3. Bidirectional AC-DC converter

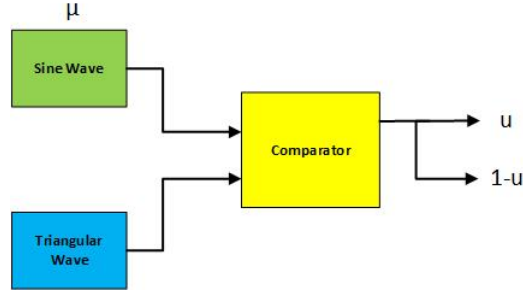

Fig. 4. PWM signal generation

During the positive half part of the cycle, in the first switching mode, the direction of current flow is shown in Fig. 5 by the arrows. The starting arrow is shown in green while the switches that are in operation during the first switching mode are shown in blue color. As seen from Fig. 5, the switches  $S_1$  and  $S_4$  are operational, while the other switches remain off.

During the negative half part of the cycle, in the second switching mode, the other pair of switches  $S_2$  and  $S_3$  are operated with a duty cycle, while the switches  $S_1$  and  $S_4$  are off. The direction of the current flow during this mode is shown in Fig. 6.

Using the Kirchoff's voltage and current laws, following averaged mathematical model of the converter has been derived in literature [6], [11]:

$$\begin{cases} \dot{x}_1 = \frac{1}{L}[-x_1 r - x_2(2u - 1) + E] \\ \dot{x}_2 = \frac{1}{C}[x_1(2u - 1) - I_{dc}] \end{cases} \quad (1)$$

where  $x_1$  and  $x_2$  are the average grid current and the average DC bus voltage, respectively, and  $u$  is the duty ratio that is used to generate the PWM signals for the switches.

### III. CONTROLLER FORMULATION OF THE TCB CONTROL APPROACH FOR THE AC-DC CONVERTER

This paper shows the applications of the technique whose mathematical formulation has been shown in [9] and [10].

As mentioned in the above papers, the approach consists of the following three steps. The first step is the generation of reference values that govern the behavior of the converter parameters. The vector of the state variables is  $\mathbf{x} = \{x_1, x_2\}$ , the control variable vector is  $\mathbf{u} = \{u\}$ , and the algebraic variable, is  $\mathbf{y} = \{y_{r0}\}$ . Here  $y_{r0}$  is the main output variable that is considered as variable of interest.

In the second step, the coordinates of the equilibrium point in the composite domain  $(\mathbf{x}, \mathbf{u})$ , denoted as  $(\mathbf{x}^*, \mathbf{u}^*)$ , are determined. This step is done by setting the derivatives in Equation (1) to zero and, hence, finding the steady-state values of the equilibrium point:

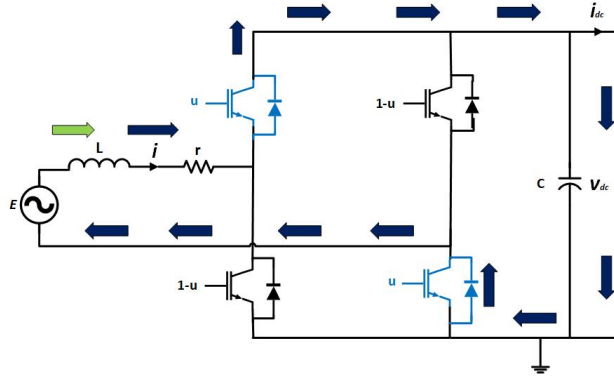

Fig. 5. Direction of current flow during the first switching mode in the positive half cycle

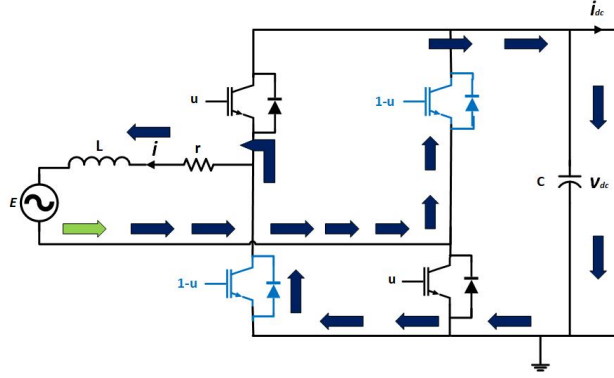

Fig. 6. Direction of current flow during the second switching mode in the negative half cycle

$$\begin{cases} x_1^* = \alpha E \\ x_2^* = y_{r0} \\ u^* = \frac{E + 2y_{r0} - \sqrt{E_1^2 - 4I_{dc}r y_{r0}}}{4y_{r0}} \end{cases} \quad (2)$$

where  $\alpha$  is given by:

$$\alpha = \frac{y_{r0}}{V^2} (-c_2 e_{x_2} C + i_{DC}) \quad (3)$$

This expression has been derived in [6] and establishes the relationship between the desired grid current and the grid voltage. The third step is to design the adaptation mechanism for the minimization of the following tracking errors:

$$\begin{cases} e_{x_1} = \alpha_1 (x_1 - x_1^*) \\ e_{x_2} = \alpha_2 (x_2 - x_2^*) \\ e_u = \beta (u - u^*) \end{cases} \quad (4)$$

Based on Equation (2) and the error vectors defined above, the expression for the control equation becomes:

$$\dot{u} = -K \left[ \frac{dx_1}{du} \alpha_1^2 (x_1 - x_1^*) + \frac{dx_2}{du} \alpha_2^2 (x_2 - x_2^*) + \beta (u - u^*) \right] \quad (5)$$

where  $K$  is the gain factor, with constant value and  $\alpha_1$ ,  $\alpha_2$  and  $\beta$  are weights defined for the errors, respectively.

The sensitivity parameters  $s_1 = \frac{dx_1}{du}$  and  $s_2 = \frac{dx_2}{du}$  are calculated based on the converter model given in Equation (1):

$$\begin{cases} \dot{s}_1 = -\frac{1}{L} (-s_1 r - 2s_2 u - 2x_2 + s_2) \\ \dot{s}_2 = \frac{1}{C} (2s_1 u + 2x_1 - s_1) \end{cases} \quad (6)$$

#### IV. SIMULATION RESULTS FOR THE AC-DC CONVERTER

The simulation for the bidirectional converter has been executed in the Matlab/Simulink environment using the ODE 45 solver. The parameters used for the converter and the values of controller gains are given in Table I and Table II. The test bench for the system is shown in Fig. 7.

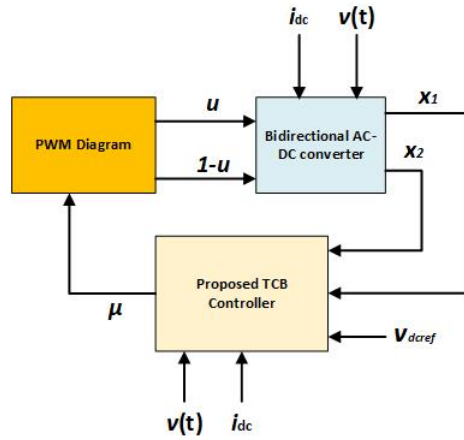

Fig. 7. Test bench setup for controller testing

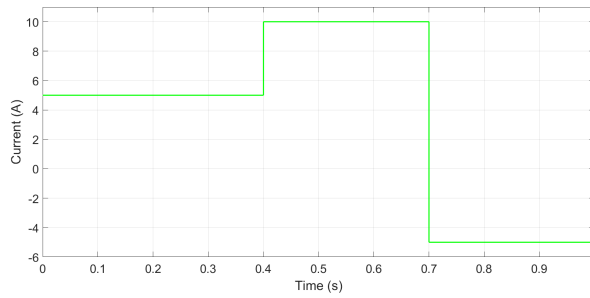

Fig. 8. DC load current

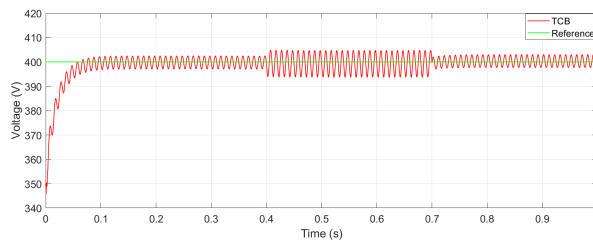

Fig. 9. DC bus Voltage

As mentioned before, the aim of the controller design is to ensure constant reference voltage tracking of the DC voltage and unitary power factor of the grid voltage and current in face of variations in the load conditions.

In each test result, the load current of the converter has been varied as shown in Fig. 8. The load current is kept constant at 5 A for time  $t = 0$  to  $t = 0.4$  s, before being increased to 10 A till time  $t = 0.7$  s. At this moment, the load current is stepped down to -5 A to show the performance of the controller in the reverse mode as well. The large sudden variations in the load current have been introduced to test the robustness of the controller under stressed conditions.

Fig. 9 shows the DC output voltage of the converter with the reference voltage set to 400 V, while Fig. 10 shows the grid current under conditions of variable load current. The starting point for the voltage in the simulation has been set to 350 V to show the initial fast adaptation to the reference target. Both figures show the effects of sudden variations in the load current.

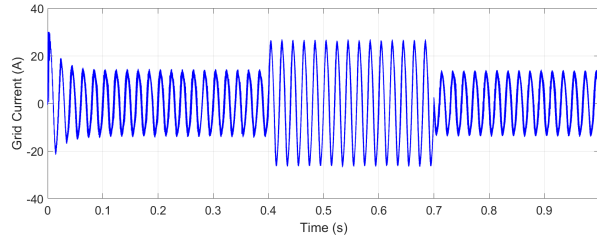

Fig. 10. Grid Current

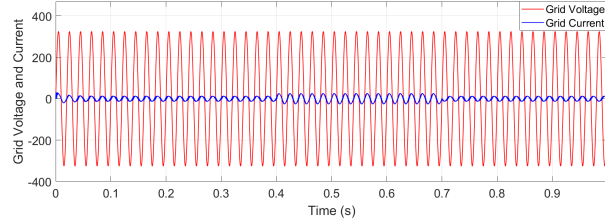

Fig. 11. Grid Voltage and Grid Current

At 0.4 s as the load current requirement is increased, the grid current also increases, but as the load current requirement is reversed the phase of the grid current shifts. This change in phase of the grid current can be better seen in Fig. 11, which shows that the phase of the grid current is opposite to that of grid voltage after  $t = 0.7$  s.

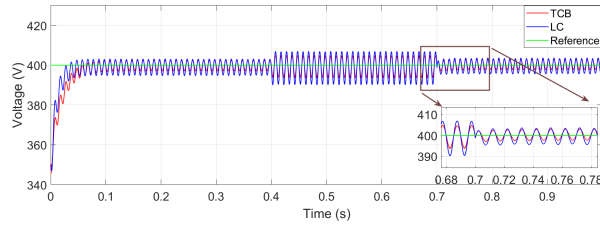

Fig. 12. DC Voltage output comparison of both controllers

TABLE I  
SPECIFICATIONS OF AC-DC CONVERTER

Description of parameters	Nominal value
Input voltage, $E$ (RMS)	230 V
Reference output voltage, $V_o$	400 V
Capacitance, $C$	3000 $\mu$ F
Inductance, $L$	4.06 mH
Load Current, $A$	5 A
Switching frequency, $f_s$	10 kHz
Inductor resistance, $R_L$	0.1 $\Omega$

TABLE II  
CONTROLLER GAINS

Description of parameters	Nominal value
TCB Gain, $K$	0.035
$\alpha_1$	3
$\alpha_2$	0.5
$\beta$	7
$c_2$	50

### A. Comparison with other controllers

To judge the performance of the proposed controller, a Lyapunov redesign based controller (LC) proposed in the literature [6] has been replicated. Both controllers were once again subject to the same external disturbances in the load current. The DC output voltage of both controllers is shown in Fig. 12.

As seen in Fig. 12, both controllers perform satisfactorily under the given circumstances. There is no overshoot voltage for both controllers with almost comparable rise time. For the TCB controller, in the case shown, there is the additional benefit of slightly smaller ripple magnitude. Both controllers have no steady state errors.

For the practical implementation of both controllers, the number of sensors required will be the same as both of them need inductor current and output DC voltage as an input. However, the LC control law implemented in [6] requires the use of derivative of the reference current which can give rise to additional complexity as derivatives of signals can be very sensitive to noise. The TCB controller does not need information on the derivatives of the signals.

## V. CONCLUSION

This paper has presented the application of a Lyapunov-based TCB controller on a bidirectional converter that acts as a single-phase active PFC circuit. The proposed controller can dynamically adjust the output power according to the grid conditions and user preferences while maintaining a high power factor, i.e., voltages and currents remain in phase in the different operational modes.

The simulations have been performed in the MATLAB/ Simulink environment. The robustness of the controller has been thoroughly tested by imposing large and stressful changes in the load current demanded from the AC-DC bidirectional converter. The results show that the proposed TCB controller performs at the same level as the other Lyapunov redesign based controller proposed in the literature, taken as the benchmark. Overall, exploiting the TCB controller appears a promising approach for improving the effectiveness of bidirectional converters such as the one considered in this paper. Our findings will be useful for researchers and practitioners working in the field of electric vehicles and power systems. In future work, the TCB methodology will be extended to three-phase systems and its performance under different grid conditions will be validated experimentally through a hardware in the loop setup.

## REFERENCES

- [1] "Electric vehicles – analysis - iea," International Energy Agency, 2022. [Online]. Available: <https://www.iea.org/reports/electric-vehicles>
- [2] M. Yilmaz and P. T. Krein, "Review of the impact of vehicle-to-grid technologies on distribution systems and utility interfaces," *IEEE Transactions on Power Electronics*, vol. 28, no. 12, pp. 5673–5689, 2013.
- [3] M. Bharathidasan and V. Indragandhi, "Review of power factor correction (pfc) ac/dc-dc power electronic converters for electric vehicle applications," *IOP Conference Series: Materials Science and Engineering*, vol. 906, no. 1, p. 012006, aug 2020. [Online]. Available: <https://dx.doi.org/10.1088/1757-899X/906/1/012006>
- [4] L. Pan and C. Zhang, "An integrated multifunctional bidirectional ac/dc and dc/dc converter for electric vehicles applications," *Energies*, vol. 9, no. 7, 2016. [Online]. Available: <https://www.mdpi.com/1996-1073/9/7/493>
- [5] K. Sayed and H. A. Gabbar, "Electric vehicle to power grid integration using three-phase three-level ac/dc converter and pi-fuzzy controller," *Energies*, vol. 9, no. 7, 2016. [Online]. Available: <https://www.mdpi.com/1996-1073/9/7/532>
- [6] A. Rachid, H. EL Fadil, F. Z. Belhaj, K. Gaouzi, and F. Giri, "Lyapunov-based control of single-phase ac–dc power converter for bev charger," in *Recent Advances in Electrical and Information Technologies for Sustainable Development*, S. El Hani and M. Essaïdi, Eds. Springer International Publishing, 2019.
- [7] R. Sabzehgar, Y. M. Roshan, and P. Fajri, "Modelling and sliding-mode control of a single-phase single-stage converter with application to plug-in electric vehicles," *IET Power Electronics*, vol. 12, no. 3, p. 620–626, 2019.
- [8] G. Mohebalizadeh, H. Alipour, L. Mohammadian, and M. Sabahi, "An improved sliding mode controller for dc/dc boost converters used in ev battery chargers with robustness against the input voltage variations," *International Journal of Industrial Electronics Control and Optimization*, vol. 4, no. 2, pp. 257–266, 2021.
- [9] M. A. Qureshi, S. Musumeci, F. Torelli, A. Reatti, A. Mazza, and G. Chicco, "Application of a novel adaptive control approach for the regulation of power converters," in *2022 57th International Universities Power Engineering Conference (UPEC)*, 2022, pp. 1–6.
- [10] M. A. Qureshi, F. Torelli, S. Musumeci, A. Reatti, A. Mazza, and G. Chicco, "A novel adaptive control approach for maximum power-point tracking in photovoltaic systems," *Energies*, vol. 16, no. 6, 2023. [Online]. Available: <https://www.mdpi.com/1996-1073/16/6/2782>
- [11] I. Ahmed, I. Ahmad, S. Ahmed, and H. M. M. Adil, "Robust nonlinear control of battery electric vehicle charger in grid to vehicle applications," *Journal of Energy Storage*, vol. 42, p. 103039, 2021.