

Energy assessment of a district by integrating solar thermal in district heating network: a dynamic analysis approach

Original

Energy assessment of a district by integrating solar thermal in district heating network: a dynamic analysis approach / Bilardo, M., Kaempf, J.H., Fabrizio, E.. - In: JOURNAL OF PHYSICS. CONFERENCE SERIES. - ISSN 1742-6588. - ELETTRONICO. - 2600:(2023), pp. 1-6. (CISBAT International Conference 2023 Lausanne (CH) 13/09/2023 - 15/09/2023) [10.1088/1742-6596/2600/5/052005].

Availability:

This version is available at: 11583/2984603 since: 2023-12-19T09:44:33Z

Publisher:

IOP Publishing

Published

DOI:10.1088/1742-6596/2600/5/052005

Terms of use:

This article is made available under terms and conditions as specified in the corresponding bibliographic description in the repository

Publisher copyright

(Article begins on next page)

PAPER • OPEN ACCESS

Energy assessment of a district by integrating solar thermal in district heating network: a dynamic analysis approach

To cite this article: M Bilardo *et al* 2023 *J. Phys.: Conf. Ser.* **2600** 052005

View the [article online](#) for updates and enhancements.

You may also like

- [The burden of premature mortality from coal-fired power plants in India is high and inequitable](#)
Dweep Barbhaya, Vittal Hejjaji, Aviraag Vijayaprakash et al.
- [Industrial symbiosis potential and urban infrastructure capacity in Mysuru, India](#)
Marian Chertow, Matthew Gordon, Peter Hirsch et al.
- [Estimation of load curves for large-scale district heating networks](#)
Kai Nino Streicher, Stefan Schneider and Martin K. Patel

PRIME
PACIFIC RIM MEETING
ON ELECTROCHEMICAL
AND SOLID STATE SCIENCE

HONOLULU, HI
Oct 6–11, 2024

Abstract submission deadline:
April 12, 2024

Learn more and submit!

Joint Meeting of
The Electrochemical Society
•
The Electrochemical Society of Japan
•
Korea Electrochemical Society

Energy assessment of a district by integrating solar thermal in district heating network: a dynamic analysis approach

M Bilardo^{1,2}, J H Kaempf¹, E Fabrizio²

¹ Energy Informatics Group, Idiap Research Institute, Rue Marconi 19, 1920 Martigny, Switzerland

² TEBE Research Group, Department of Energy, Politecnico di Torino, Corso Duca Degli Abruzzi 29, 10129 Turin, Italy

* Corresponding author m.bilardo@idiap.ch

Abstract. This work focuses on the energy upgrade of a neighbourhood located in Yverdon-les-Bains, Switzerland. Starting from a potential low-temperature district heating network, the possible integration of new buildings equipped with solar thermal collectors capable of interacting with the network is explored. The methodology proposed in this work focuses on the study of the energy balance of the district at reduced time intervals. Bringing the level of detail to every single hour of the year, the concept of energy balance is superseded by the hourly averaged power balance as a specific tool for a detailed exploration of the energy flows exchanged within the district. Self-sufficiency has also been identified as key performance indicators to better understand the ability of the entire district to satisfy its heating and domestic hot water needs, modelled in CitySim's urban energy environment. The outcomes have shown that an annual energy balance is ineffective and unrealistic for describing performances of the district. On the other hand, the hourly averaged power balance proves to be a powerful tool for understanding the dynamics of the neighbourhood. The district's energy flexibility, which relies on energy sharing, is a characteristic that cannot be assessed annually. Using the new proposed methodology to evaluate the district's thermal energy sharing, it was discovered that the district functions as a Zero Energy District for 28.9% of the year. With the outcomes presented in this study, it is now possible to comprehend how a dynamic performance assessment positively impacts a district's redevelopment strategies.

1. Introduction

The energy consumption in buildings is a significant sustainability concern as they account for a significant portion of global energy demand. Addressing this issue is crucial to minimize their environmental impact and ensure a sustainable future [1]. Heating and domestic hot water usage are particularly important factors to consider in reducing overall energy demand in buildings. In urban areas, where energy demand is concentrated and population growth is rapid, the issue becomes even more critical [2]. Energy-based communities have emerged as a viable solution [3], encouraging the sharing of resources like renewable energy generation and storage, along with the adoption of energy-efficient technologies and practices [4]. In the pursuit of sustainability and energy efficiency at the community level, district heating technologies have emerged as a promising option [5], offering opportunities for energy sharing and technical implementations. One notable advantage of district heating is their ability to integrate renewable technologies seamlessly. Solar thermal collectors, waste



heat recovery systems, and biomass generators can be easily incorporated into these networks, promoting district heating as a viable alternative to electrification [6]. Governments worldwide have set ambitious decarbonization goals, and exploring district heating networks as an efficient and sustainable heating solution aligns with these objectives. Additionally, research efforts have focused on improving and optimizing thermal networks, as well as integrating state-of-the-art renewable technologies [7].

1.1. Aim of the work

This paper focuses on the energy performance assessment of a realistic district heating network layout that is potentially expanding by integrating new buildings and renewable sources within the network. The study aims to evaluate energy performances by adopting a novel methodological framework that accounts for the dynamics of the buildings and technical systems involved. In particular, this paper compares an energy assessment conducted on an annual basis with an hourly dynamic assessment, shifting the focus from a static annual energy balance to an hourly averaged power balance, comparing a state of design with a possible expansion of the thermal network by integrating new buildings and solar thermal panels. This research has a twofold objective: on the one hand, it emphasizes the importance of a dynamic approach in assessing the energy performance of buildings. On the other hand, it contributes to the existing body of knowledge on district heating networks and their role in sustainable energy transitions. The findings of this study are expected to provide insights into the effective utilization and energy assessment of district heating networks, offering a novel methodological approach for enhancing energy efficiency and sustainability at the neighborhood level.

2. Material and methods

2.1. Case study and energy systems

The case study consists of a small district made up of nine existing buildings connected to a 4th generation low temperature district heating network (DHN), located in the municipality of Yverdon-les-Bains, Switzerland. Currently (2022 scenario), the DHN provides heating and domestic hot water for all connected buildings. Future expansions are planned, including the construction of nine new buildings that can be connected to the existing DHN. These new buildings may also have solar thermal systems on their roofs, contributing to their energy needs and potentially exporting thermal energy to the district heating network [8]. The choice of the case study is relevant since it presents itself as a perfect scenario for demonstrating how a dynamic evaluation approach on an hourly basis can both support the design phase of thermal network expansion and be used as an accurate method for evaluating realistic system performance. Figure 1 illustrates the district expansion plan, showcasing the existing buildings (blue and pink) representing the 2022 scenario, and potential future expansions by 2030 (orange and green buildings - from Block 1 to 9) integrated into the district heating network (DHN) in the 2030 scenario. All buildings, both existing and new, are connected to the same DHN and utilize a double thermal storage system for heating and domestic hot water. Figure 1 also depicts the simplified layout of the district heating network, emphasizing the potential for thermal energy sharing among the buildings in the 2030 scenario [9].

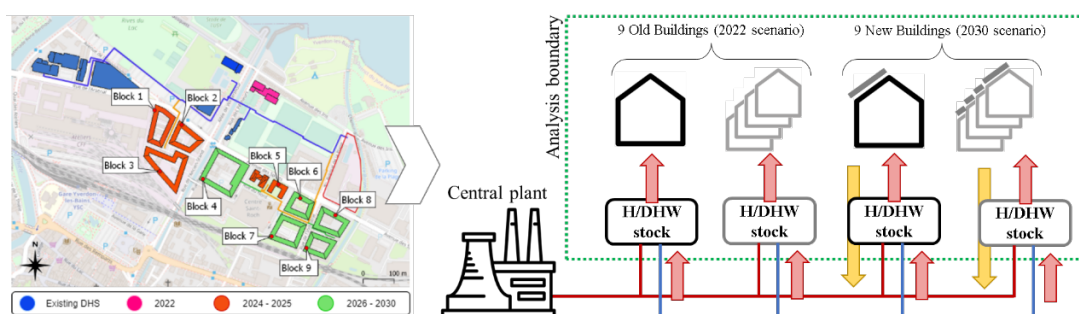

Figure 1. District case study and system layout comparison (2022 scenario vs 2030 scenario).

Specifically, all buildings are equipped with a similar system to satisfy heating and DHW need ($Q_{H,nd}$ and $Q_{DHW,nd}$ respectively), composed of two separate storage tanks (H_{st} and DHW_{st}) fed from the DHN through the $Q_{DH,H}$ and $Q_{DH,DHW}$ flows for heating and domestic hot water respectively. HVAC system layout is described in Figure 2.

In addition, the new buildings are equipped with a solar thermal system, capable of producing thermal energy ($Q_{ST,prod}$) for H_{st} and DHW_{st} (by means of the $Q_{ST,H}$ and $Q_{ST,DHW}$ flows respectively), and exporting excess heat to DHN ($Q_{ST,exp}$). The system control logic gives priority to the DHW requirement over H. As regards buildings with a solar thermal system, self-consumption always takes priority over export. The main geometric and physical characteristics of the buildings and their respective HVAC systems are based on previous studies on the case study [10]. For existing buildings, real properties have been investigated and implemented in the model, whereas for buildings under construction, choices have been made based on design data and thermals energy needs of buildings. DHW_{st} can satisfy the daily usage of the occupants (50 lt/day), while H_{st} is able to meet the heating demand of an average winter day. Solar thermal systems have been designed to cover 70% of the roof surfaces in all new buildings.

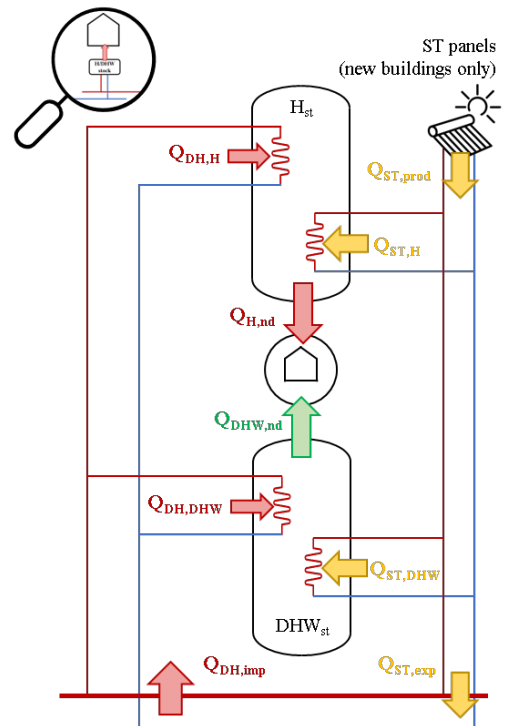

Figure 2. Storage tanks system layout integrated in the simulation environment.

2.2. Simulation environment

The entire district was modeled using the dynamic city-scale simulation environment CitySim [11], [12]. Previous studies have focused on building modeling and their calibration with real data [10], while HVAC systems have been implemented for the purposes of this work. The result is a dynamic model capable of simulating the trend of hourly energy flows shown in Figure 2.

2.3. Dynamic assessment methodology: hourly-averaged power balance and the Zero Power concept

This paper proposes a new methodology for a detailed energy assessment that is more consistent with reality. The case study district is assessed solving a power balance on an hourly basis, over the entire district boundary. This approach aims to evaluate the dynamic behavior of the district, understanding real opportunities for energy sharing. From this point of view, the averaged power balance aims to overcome the classic concept of yearly energy balance, often used as a performance assessment metric to evaluate whether a district can be considered a net Zero Energy District. The methodology applied in this work starts from the well-known concept of Zero Energy Building/District (ZEB/ZED) [13], based on the null result of the energy balance described by Equation (1).

$$E_{bal} = E_{exp} - E_{imp} \quad [\text{kWh}] \quad (1)$$

Where E_{bal} represents the difference between exported (E_{exp}) and imported (E_{imp}) energy from the entire district. A zero value of E_{bal} means achieving the net ZED target. The main weakness of this approach lies in the time interval over which the energy balance is solved, usually on an annual or monthly basis, which is not representative of the real behavior of the building and above all with the risk of generating misleading results [14]. This work proposes to go beyond the concept of an annual energy balance by proposing an hourly averaged power balance, where the ZED definition of Equation (1) is superseded by the Zero Power District (ZPD) definition, represented by Equation (2), in which the district's performance is evaluated with a reduced hourly timestep by solving the balance of the energy flows involved.

$$\bar{P}_{bal,t_{ref}} = \sum_{i=1}^{t_{ref}/\Delta t} \frac{1}{\Delta t} \int_{(i-1)\Delta t}^{i\Delta t} P_{exp}(t) dt - \sum_{i=1}^{t_{ref}/\Delta t} \frac{1}{\Delta t} \int_{(i-1)\Delta t}^{i\Delta t} P_{imp}(t) dt \quad [\text{kW}] \quad (2)$$

Where $\bar{P}_{bal,t_{ref}}$ represents the difference between exported and imported energy flows, evaluated with an hourly detail (analysis timestep $\Delta t=1\text{hr}$) for each i -th interval composing the total reference time of the analysis $t_{ref}=1\text{yr}$. In the selected case study, the concept of power balance was applied to the thermal flows involved in the energy import/export boundary between the district heating network and the buildings integrated in the network. To support the hourly averaged power balance, the dynamic evaluation of the district's energy performance can be complemented by the use of KPIs. Even for them, an evaluation based on aggregated yearly values often leads to misleading and unreliable results. Therefore, in this paper, a dynamic hourly KPIs evaluation methodology is proposed, describing the dynamic trend of an entire year by means of the KPI accuracy (a_{KPI}) evaluation in Equation (3).

$$a_{KPI} = \frac{1}{N} \sum_{i=1}^N \text{count}[|KPI_i - KPI_{target}| < \varepsilon] \quad [-] \quad (3)$$

Where N is the total number of samples. In this work $N = \Delta t/t_{ref}$, KPI_i is the evaluated KPI at the i -th time interval, KPI_{target} is the KPI target value, set to 100%, and ε is the acceptable error set to 20%. For the purposes of this work, Self-Sufficiency (SS) of the district was evaluated as KPI, representing the ability of the network to be self-sufficient from external energy sources (represented by the DHN central plant). SS was evaluated using Equation (4), referred to energy flow presented in Figure 2.

$$SS = \frac{Q_{ST,H} + Q_{ST,DHW}}{Q_{H,nd} + Q_{DHW,nd}} \quad [-] \quad (4)$$

3. Results and discussion

3.1. Yearly energy balance vs Hourly averaged power balance

The annual energy balance of the entire district is shown in Figure 3. In particular, the annual energy balances before and after the district upgrading are compared in Figure 3a and Figure 3b, respectively. The construction of the new buildings results in an increase of the district's heat demand for H and DHW from approximately 7 to 15.4 GWh (red bars). However, the installation of the solar thermal system gives the district 14.8 thermal GWh that are potentially exported to the thermal grid and made available to the existing buildings. Through this preliminary analysis it is possible to draw up a thermal balance of the district, which after the installation of the solar thermal system, is able to bring the district's thermal balance closer to zero, approaching the Zero Energy District target. This result, obtained by solving Equation (1), is represented by the grey bar in Figure 3, which describes the E_{bal} quantity.

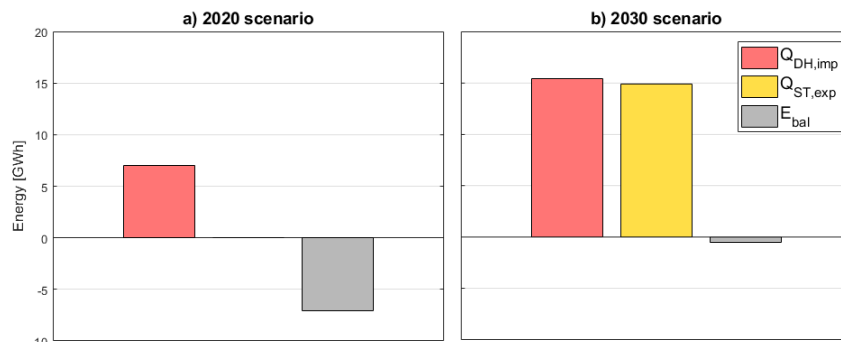

Figure 3. Yearly energy balance: 2022 scenario (a) vs 2030 scenario (b).

Shifting the focus to a reduced temporal analysis, the result of the application of the hourly averaged power balance, obtained by solving Equation (2), is presented in Figure 4. Equation (3) was solved during every hour of the year, for the 2030 scenario, the only one capable of generating a positive balance result due to renewable production. Figure 4 shows both the annual evolution (a) and the sorted representation of the results (b). The result obtained, when compared to the annual analysis, is discordant. In fact, the district only reaches the Zero Power District target for 2562 hours per year

(28.9% of the year), behaving as a thermal energy exporter (positive balance), mainly during the summer season. During the rest of the year, the heat demand is not covered by onsite production. This approach demonstrates how the classical annual analysis often tends to overestimate the district's energy performance without taking into account the dynamic behavior of the buildings involved.

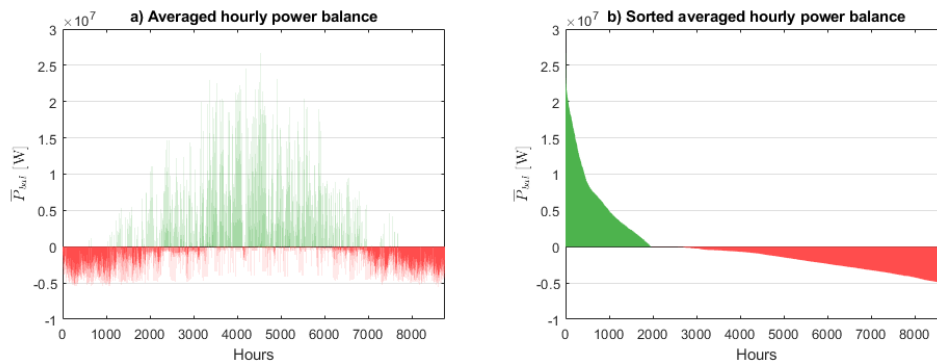

Figure 4. Hourly averaged power balance in 2030 scenario: yearly evolution (a) and sorted values (b).

3.2. Self-sufficiency accuracy (a_{SS}) for 2030 scenario

The specific performance of the 2030 scenario was also assessed through Self-sufficiency. In particular, SS was assessed dynamically by solving Equation (4) at each hour of the year. Again, the results were limited to the 2030 scenario, the only one capable of generating non-zero results. Figure 5a depicts the annual KPI trend, while Figure 5b orders the results in a decreasing manner. According to this methodological approach, it is straightforward to understand how the district's SS is clearly favored during the summer months, given the higher solar thermal production. In addition, the dynamic study of the KPI evolution makes it possible to understand when the district behaves as a self-consumer hour by hour, opening up numerous possibilities not only for evaluation but also for optimization.

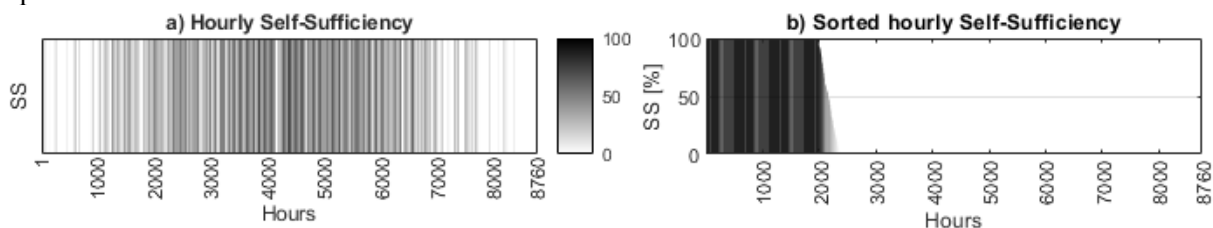

Figure 5. Hourly Self-Sufficiency in 2030 scenario: yearly evolution (a) and sorted values (b).

From the dynamic analysis of self-consumption, it is possible to assess the SS accuracy (a_{SS}) as a summary indicator of the district's annual performance. By applying Equation (3), after establishing an accuracy margin of $\varepsilon=20\%$, it is possible to compute the value of a_{SS} , which for the selected case study is 23.39%. This result indicates that for 23.39% of the hours during the year, the district performs highly in terms of self-consumption ($SS>80\%$). The choice of an accuracy margin ε of 20% was adopted for the sole purpose of this work. The variation of ε is closely related to the result of a_{SS} . The relationship that exists between these two quantities will be explored further in subsequent studies of the proposed methodology, especially in terms of suggesting new benchmark indices for building assessment. The concept of SS accuracy clashes with the static SS result assessed on cumulative energy flows over the whole year, which stands at 21.67%. Although the two results are not comparable, a_{SS} better describes the performance dynamics of the district, which is impossible to capture through the annual evaluation of a KPI.

4. Conclusion

The work presented in this paper focused on the performance evaluation of a realistic district undergoing redevelopment. The evaluation of energy performance was performed through a new

methodological approach based on the definition of the hourly averaged power balance, which can dynamically describe the district's energy balance. In addition, the district's self-consumption was evaluated by defining its accuracy over the course of an entire year. The results obtained, compared with classical methods based on annual aggregate analyses, made it possible to describe the district's energy behavior without neglecting the dynamics of performance. For 28.9% of the hours, the district performs as Zero Energy District, while the accuracy of its self-consumption is around 23.39%.

The potential of the applied method lies in its ability to consider the real dynamic evolution of the phenomena involved in building performance, especially when on-site renewable generation systems are involved. The proposed methodology aims to provide stakeholders with a tool for a more flexible design and management of energy resources within a district. The results of this work lay the foundation for possible optimization activities of energy systems, both in design and operation. The possible implications brought about by the application of the proposed method certainly lie in an increased effort in the design and evaluation phase. However, the proposed approach not only guarantees greater accuracy in the results, as demonstrated in this work, but also anticipates future regulatory developments, which will certainly tend towards a dynamic analysis of building performance. For instance, the dynamic evaluation method proposed in this work set up a novel framework for future energy certification methods for buildings, aiming to limit the gap between design and operation that often plagues current annual static performance indices. Furthermore, the evaluations achieved in this paper have highlighted the often-invisible gaps in the annual static analysis of the performance of a solar thermal system serving an entire district. Just as the proposed method is able to offer an accurate and realistic analysis of energy performance, it could likewise be used as an evaluation benchmark to propose new technologies to be integrated in the district, such as a seasonal thermal storage system.

References

- [1] IEA - International Energy Agency, *Energy and CO2 emissions in the OECD*. 2016.
- [2] V. Todeschi, R. Boghetti, J. H. Kämpf, and G. Mutani, "Evaluation of Urban-Scale Building Energy-Use Models and Tools—Application for the City of Fribourg, Switzerland," *Sustainability 2021, Vol. 13, Page 1595*, vol. 13, no. 4, p. 1595, Feb. 2021, doi: 10.3390/SU13041595.
- [3] H. Roby and S. Dibb, "Future pathways to mainstreaming community energy," 2019, doi: 10.1016/j.enpol.2019.111020.
- [4] M. Bilardo, F. Cattaneo, E. Dioni, E. Liberi, L. Milocco, and G. Serale, "Community Energy for enhancing the energy transition," *CERN Ideasq J Exp Innov*, vol. 4, no. 2, pp. 7–18, Dec. 2020, doi: 10.23726/CIJ.2020.1050.
- [5] B. Talebi, P. A. Mirzaei, A. Bastani, and F. Haghghat, "A review of district heating systems: Modeling and optimization," *Front Built Environ*, vol. 2, 2016, doi: 10.3389/fbuil.2016.00022.
- [6] H. Lund *et al.*, "4th Generation District Heating (4GDH). Integrating smart thermal grids into future sustainable energy systems.," *Energy*, vol. 68, pp. 1–11, 2014, doi: 10.1016/j.energy.2014.02.089.
- [7] M. Bilardo, F. Sandrone, G. Zanzottera, and E. Fabrizio, "Modelling a fifth-generation bidirectional low temperature district heating and cooling (5GDHC) network for nearly Zero Energy District (nZED)," *Energy Reports*, Jun. 2021, doi: 10.1016/j.egy.2021.04.054.
- [8] M. Sameti and F. Haghghat, "Optimization approaches in district heating and cooling thermal network," *Energy and Buildings*, vol. 140, Elsevier Ltd, pp. 121–130, Apr. 01, 2017, doi: 10.1016/j.enbuild.2017.01.062.
- [9] E. Guelpa and V. Verda, "Thermal energy storage in district heating and cooling systems: A review," *Appl Energy*, vol. 252, 2019, doi: 10.1016/j.apenergy.2019.113474.
- [10] P. Van Brockhoven, "Solar Thermal Energy In A District Heating System: A Case Study Analysis," Haute Ecole Libre Mosane, Liège, 2021.
- [11] G. Mutani, S. Coccolo, J. Kaempf, and M. Bilardo, *CitySim Guide: Urban Energy Modelling*, 1st ed. CreateSpace Independent Publishing Platform: CreateSpace Independent Publishing Platform, 2018. Accessed: Oct. 17, 2022. [Online]. Available: <https://www.amazon.de/CitySim-Guide-Urban-Energy-Modelling/dp/1987609735>
- [12] F. Johari, G. Peronato, P. Sadeghian, X. Zhao, and J. Widén, "Urban building energy modeling: State of the art and future prospects," *Renewable and Sustainable Energy Reviews*, vol. 128, p. 109902, 2020, doi: 10.1016/j.rser.2020.109902.
- [13] I. Sartori, A. Napolitano, and K. Voss, "Net zero energy buildings: A consistent definition framework," *Energy Build*, vol. 48, pp. 220–232, 2012, doi: 10.1016/j.enbuild.2012.01.032.
- [14] J. Salom, A. J. Marszal, J. Widén, J. Candanedo, and K. B. Lindberg, "Analysis of load match and grid interaction indicators in net zero energy buildings with simulated and monitored data," *Appl Energy*, vol. 136, pp. 119–131, 2014, doi: 10.1016/j.apenergy.2014.09.018.