

N.Georgescu-Roegen's production model for EROI evaluation. Case study: Electrolytic H2 production using solar energy

*Original*

N.Georgescu-Roegen's production model for EROI evaluation. Case study: Electrolytic H2 production using solar energy / Ruggeri, B; Gomez Camacho, Carlos. - In: ENERGY CONVERSION AND MANAGEMENT. - ISSN 0196-8904. - STAMPA. - 283:(2023), pp. 1-17. [10.1016/j.enconman.2023.116915]

*Availability:*

This version is available at: 11583/2984468 since: 2023-12-12T12:14:27Z

*Publisher:*

Elsevier

*Published*

DOI:10.1016/j.enconman.2023.116915

*Terms of use:*

This article is made available under terms and conditions as specified in the corresponding bibliographic description in the repository

*Publisher copyright*

(Article begins on next page)



# N.Georgescu-Roegen's production model for EROI evaluation. Case study: Electrolytic H<sub>2</sub> production using solar energy

Bernardo Ruggeri<sup>a,\*</sup>, Carlos E. Gómez-Camacho<sup>a,b</sup>

<sup>a</sup> DISAT, Dep. Applied Science and Technology, Politecnico di Torino, C/so Duca degli Abruzzi, 24, 10129 Torino, Italy

<sup>b</sup> EMPA Swiss Federal Laboratories for Materials Science and Technology, Technology and Society Laboratory, Lerchenfeldstrasse 5, St. Gallen CH-9014, Switzerland

## ARTICLE INFO

### Keywords:

Green hydrogen production  
N.G. Roegen stocks/funds production function  
NEA Analysis  
EROI methodology  
CED (Cumulative Energy Demand)  
GER (Global Energy Requirement)

## ABSTRACT

Nowadays there is a considerable interest in studying the direct and indirect energies involved in products and services. This is particularly critical when novel energy resources are exploited by complex technological chains and to determine if they can indeed guarantee a *useful energy* societal supply. Unfortunately, there is no universally accepted procedure for doing this. The present paper aims to suggest a new procedure to evaluate the EROI of technologies producing energy carriers based on the *stocks/flows-funds/services* production model of N.G. Roegen. The suggested method can uniquely identify the energy flows involved in the technology consistent with biophysical and anthropological boundaries. This analytical formulation can be used either for single technologies or combination of them in series or parallel using different energy resources. Specific recommendations in the use of the Cumulative Energy Demand and Global Energy Requirements in the Net Energy Analysis, as well as in the evaluation of both for an electrical system are reported. The approach is here applied to the analysis of electrolytic H<sub>2</sub> production using electricity produced by a photovoltaic panel ("green hydrogen"). The resulting EROI = 0.97 means that the technology is not sustainable, requiring 3% energy from the anthropological sphere to support it. The paper is organized as follows: providing a narrative model for EROI evaluation consistent with anthropological and biophysical spheres; covering the definition of *stocks/flows-funds/services* model for EROI evaluation; analysing and suggesting uses of the model for energy technologies scoring and selection based on sustainability and presenting a numerical case study.

## 1. Introduction

Sustainability results to be in different range of meanings, being a flexible concept used with different scope in specific context suggesting the diversity of many valid meanings of versions of sustainability [1]. The concepts of *sustainable development* and *sustainability* have acquired great relevance in scientific research on environmental issues, policy-making linked to environmental management, industrial and agricultural productions patterns, among others. Frequently both terms are used as synonyms, but a great debate envelops them regarding their applicability in different specific contexts, being nations, environmental matrices, or technologies [2]. According to [3] the concept of

sustainability in the ground of systems theory implies its application to real systems endowed with material existence; these systems must be necessary open and therefore capable of exchanging matter, energy, and information with their surroundings. These exchanges tend to be represented as input/output flow variables, which ultimately determine the state variation of systems over time.

This article focuses on the energy sustainability of technologies for energy carriers (EC) production. This aspect is crucial for novel energy technologies development entailing three synergistic domains: technological/environmental, political/social, and economical/financial, as a set of interrelated elements of real complex systems [4].

Modern society exhibits an ever-increasing energy demand trend: the

*Abbreviations:* APER, Anthropological Primary Energy Resource; BOP, Balance-of-plant; BOS, Balance-of-system; CED, Cumulative Energy Demand; EC, Energy Carrier; EL, Electrolyser; EROI, Energy Return On Investment; ESI, Energy Sustainability Index; ETC, Energy Technology Chain; FS, Funds/services; GER, Global Energy Requirement; LCA, Life Cycle Assessment; LHV, Lower Heating Value; NEA, Net Energy Analysis; PEM, Polymer Electrolyte Membrane; PER, Primary Energy Resources; PHS, Pumping Hydro Storage; PV, Photovoltaics; R&D, Research and Development; SF, Stocks/flows; SFFS, stocks/flows-funds/services; SMR, Steam Methane Reforming; T, Transmission grid; TRL, Technology Readiness Level.

\* Corresponding author.

E-mail address: [bernardo.ruggeri@formerfaculty.polito.it](mailto:bernardo.ruggeri@formerfaculty.polito.it) (B. Ruggeri).

<https://doi.org/10.1016/j.enconman.2023.116915>

Received 20 September 2022; Received in revised form 21 February 2023; Accepted 7 March 2023

Available online 22 March 2023

0196-8904/© 2023 The Authors. Published by Elsevier Ltd. This is an open access article under the CC BY license (<http://creativecommons.org/licenses/by/4.0/>).

electricity demand is forecasted to further grow at a yearly rate of  $>3\%$  [5], the share of harvested renewable Primary Energy Resources (PER) is expected to increase to partially to cover the growth. The demand will be driven in the short-term by different factors in developing countries and developed ones. In the first group the electrification of key energy services will play the main role, while in the second one the increased number of electricity users, mainly for private transportation [5] will be the predominant drive. In the long-term, the need to substitute fossil PER with renewable one will heavily impact on the electrification of energy services [6]. However, the effects of the 2020 crisis on the energy sector has disrupt previous predictions, the total energy demand seems to have undergone a reduction of c. 5.3 % and of 6.6 % for CO<sub>2</sub> emissions compared to 2019, while renewables modestly increased (0.9 %) [7]. But whereas the true extend of the effects of pandemic still need to be assessed, policy makers and the civil society might be in front of one unique opportunity to accelerate the transition towards sustainable energy production and consumption patterns.

Although there is an urgent need to reshape energy supply chains and the global shares of fossil and renewable PER [8], the energy sector still lacks a straight-forward common vision, to guide scientist in the development of novel technologies, consumers into sustainable choices and policymakers into suitable allocation of economic resources [9]. The crux of the matter involves a basic and intuitive concept: *energy is required to convert primary energy resources (PER) into energy carriers (EC)*. Consequently, all energy expenses become unusable to covering energy services in the anthropological domain (e.g., food production, health care, education, culture in a broad sense, mobility, etc.). Indeed, the anthropogenic exploitation of PER either of renewable or non-renewable nature, requires effort and energy expenses. For an accurate energy accounting, a labelling phase of these energy flows is necessary.

Energy from a semantic point of view can be labelled, as follows:

i) *available energy*: the energy present in a PER, such as the solar photon energy arriving on a surface, the geodetic difference of a watercourse or the energy contained in petroleum/natural gas in reservoirs etc.

ii) *accessible energy*: the maximum attainable energy by a process (a fraction of the *available energy*), considering the thermodynamic efficiency limit of the process imposed by the operative conditions. Carnot

efficiency in the case of thermal process and Gibbs's efficiency in processes involving chemical end electrochemical reactions. The *accessible energy* differs from the exergy concept, since the latter does not depend on the operating conditions of the process, but rather from fixed reference conditions called "*dead state*" (the ambient temperature/pressure and for elements, some reference chemical compositions in environmental matrices) [10].

iii) *useful energy*: actual share of energy as EC produced by a specific Energy Technology Chain (ETC) discounting all the energy required by the technology itself for the construction and operation. This share is the only one which can cover then societal energy services.

The notion of energy services belongs to the anthropological sphere and in techno-economic contexts its introduction was motivated by the consideration that people do not demand energy *per se* but desire the services provided by its use [11]. For example, humans do not demand electricity or gasoline, but they use these ECs as means to fulfil different social purposes. However, the quality of *useful energy* (even if different types are measured quantitatively in the same units) plays an important role determining the type of energy service that can be provided. This energy share (needed to transform resources into adequate EC) is subtracted from the anthropological sphere (Fig. 1) and, hence, it is no longer available to cover energy services. Human (animal) bodies energetically require edible carbon forms (e.g., carbohydrates, lipids, proteins), while transportation services (provided by machines) are covered by hydrocarbons. Hence, technological steps require to meet a specific EC quality add complexity to EC technology chains (and further decrease the *useful energy* supply). This occurs in the transformation of fossil energy into edible energy through the production of H<sub>2</sub> from methane or oil, its conversion into NH<sub>3</sub>, the production of fertilizers and the use of them to produce cereals for the food supply chain. The *useful energy* represents only a fraction of the *accessible energy*, since all the energy necessities of the technology chain have been discounted. All over, EC producing technologies are sustainable to the extent that they produce *useful energy* and they can be ranked based on these flows. These ideas have been present in the scientific community during the last century, but they have only recently received proper attention [12].

Nowadays, the energetics of a technology are analysed through two broad methodologies: Life Cycle Assessment (LCA) [13] and Net Energy Analysis (NEA) [14]. Unfortunately, drawing thorough energy balances

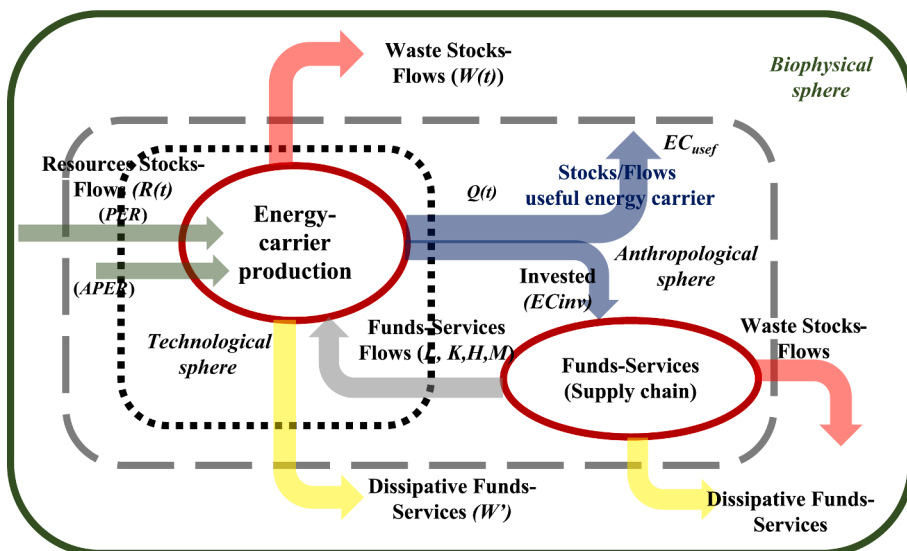

**Fig. 1. Bioeconomic model of Energy Carrier (EC) production.** The technology system presents two boundaries with different spheres: anthropological and biophysical.  $R(t)$ : energy stocks/flows inputs cross the boundary of the biophysical sphere in the case of renewable resources, while they arrive from the anthropological sphere in the case of non-renewable ones. This semantic distinction is fundamental since, in the second case, a share of EC has already been spent to obtain the stocks/flows at the gate of the technology. Particular attention should be paid to cultivated biomass resources which, although renewable, also require EC expenditures.  $W(t)$ : waste stocks/flow are generated by entropic degradations due to the transformation of resources into ECs; it can be constituted either by energy alone (heat) as occurs in the case of *immaterial* resources (solar radiation, hydro, waves, wind, etc.) or by energy and matter as for *material* resources (gas, oil, coal, biomass).  $W'$ : dissipative funds-services flows, are the fluxes due to the entropic degradation of the other class of production factors  $L, K, H, M$  (see text), which are necessary for the transformation of resources into carriers.  $Q(t)$  output stocks/flows as the produced EC.  $EC_{inv}$ : invested energy, the EC necessary to maintain funds/services in adequate conditions during their

technological life.  $EC_{usef}$ : the *useful energy carrier* for the coverage of energy services in the anthropological sphere. *Funds-Service (Supply chain)*: all the activities at the anthropological sphere necessary to maintain and operate the system (see text).

based on these methodologies requires consistent tracking and labelling energy contributions [15], and in many situations, the two techniques are confused and mixed [16]. To proceed with a correct analysis of energy sustainability it is well to recall the aims and purposes of the two approaches which are very different. LCA applied to process energetics tends to focus on the depletion of (energy) resources extracted from the biophysical sphere (i.e., including the fossil PER depletion and the additional quantity of required ECs) to obtain a certain product or service. In LCA, the energy footprints are referred to the biophysical sphere, including the renewable PER share. The results of LCA are computed using different indicators to assess the impact on a given biophysical component (atmosphere, biosphere, hydrosphere, cryosphere, etc.) of the planet, following specific methods of aggregation and characterization factors. On the other hand, NEA seeks rather the net energy balance of the technology, hence NEA focuses on technosphere footprints and not on the biophysical sphere. NEA is a scientific discipline out of the energetic theory of value in economics, belonging to the groove created by Nicholas Georgescu-Roegen, who deserves a category unto himself in the energy analysis of the economy [17]. Despite, the two approaches present some equivalent characteristics (i.e., life cycle thinking or input–output accounting), they provide different results due to their above-mentioned conceptual differences. LCA makes a clear distinction between the use of renewable and non-renewable resources, conversely, the NEA yields the net energy regardless of the shares to transform PER or Anthropological Primary Energy Resource (APER) as wastes or corn [18] into ECs.

Both energy accounting procedures (LCA and NEA) are also susceptible to subjective aspects, which are critical for energy statistics and energy assessments. Common issues regarding energy accounting include: the boundaries between the biophysical-anthropological-technology systems, the validity of the underlying epistemological representation of the EC process as a *black-boxes* (i.e., exclusively in terms of inputs-outputs), the asynchronicity of production factors at the different life stages of a process (i.e., R&D, construction, operation, decommissioning) and relative energy intensities. In addition, the controversial use of energy conversion factors between renewables, nuclear, biomass-based and fossil resources [19], as well as the correct utilization of heating values (e.g., higher or lower) are source of misunderstandings and tend to lead to different results.

Under the NEA approach, the Energy Return On Investment (EROI) has received increasing attention [20]. Despite its simple definition as the ratio between the produced *net energy* and the *invested energy* in the system, over time several mathematical formulation have been proposed [21]. Although in [22] several aspects for EROI calculation are highlighted (e.g., the accounting of fossil and renewable resources), the lack of a general mathematical framework prevents the comparison of different estimations, although attempts at standardization have been made [23]. EROI metrics have proven useful to study energy in different contexts, notwithstanding, most of the research relies on large-scale macroscopic data (historic collection of sectors and/or nations), which is often difficult to couple with single level technological realities. Hence, direct comparisons between facility-scale EROIs and aggregated geographical regions/industries EROIs as a ratio of annual energy flows [24] can significantly diverge (particularly for technologies at infancy state [25]). Indeed, recent debates [26] have also addressed the choice of production factors and life stages that should be considered for EROI calculations, and the significance of “*energy investments*” required for the construction and decommissioning of the plant [27]. This is of utmost importance referring to the calculation of EROI of electrical energy production [28]. The lack of consensus in the scientific community regards several aspects: how to consider the thermal content of “*electricity*” as the product of power plants or/and “*the product produced with the electricity output of the power plant*” [29]. In the *rebuttal* [30] additional questions are raised as the weighting factor to be used for renewable technologies involving suggested guidelines [31], too. Most of these debates have been centred on the photovoltaic (PV) case-study,

which is only one key technology for the future renewables mix. Unfortunately to date, there is a lack of usable conceptual frameworks able to guide scientists, practitioners, and policy makers into game-changer EC producing technologies. In addition, considering that estimates of renewable EROIs are lesser than fossils and the need of increasing their use towards net zero carbon energy systems, a careful evaluation of the EROI of these technologies is strongly requested [32].

The novelty of this work is the use of Roegen’s production function to formalize EROI calculations for technologies that produce ECs. The Roegen’s production function distinguishes between *stocks/flows* and *funds/services* and hence, it can help to reduce all issues of either methodological or substantive nature above recalled, for EROI calculations on a comparable basis. The paper analyses all the energies involved in a technology and for each of them suggests an accounting procedure for the calculation. Particular attention is devoted to the evaluation of the embedded energy shares in the materials/chemicals required to run the process. To this end, a critical analysis of the values reported in databases (Cumulative Energy Demand, CED and Global Energy Requirement, GER) is conducted, suggesting suitable calculation methods. Lastly, a numerical example as case-study concerning the production of *green hydrogen* by PV electricity and electrolysis is proposed and analyzed in detail.

## 2. Methods

### 2.1. Conceptual framework for the energy carrier technology

The application domain of NEA and EROI calculations is restricted to technologies, whose objective is the transformation of energy resources into ECs. Here it is important to underline the difference between energy and EC. Energy can be defined as an entity contained in a resource, potentially able of producing a change, it can belong either to the biophysical sphere PER or to the anthropological one APER, it can be neither created nor destroyed. Conversely, ECs can (must) be produced in an adequate form to cover energy services, and are destroyed; obviously the energy they contain is conserved but it is entropically degraded. The difference between energy resources and carriers lies in the technology, the former are “*gifts*”, the latter are the “*fruit of human activity*” hence their production requires the expenditure of ECs. Consequently, only those technologies that produce a positive value of *useful energy* can be considered sustainable. The energy analysis performed by NEA tries to give answers to main questions as:

- i) Is the EC gained in a process greater than energy expenses for its production?
- ii) Are such EC technologies “*vital*” and not merely “*possible*”? Is the produced EC capable of supporting the construction/operation of the technology?
- iii) How to choose between different technologies that use the same (A)PER the one that produces more EC?
- iv) How to choose from the plethora of EC producing technologies at infancy state (i.e., Technology Readiness Level, TRL < 3) those that are likely to be energy sustainable?

These considerations are important to fully understand the key elements for the evaluation of energy sustainability metrics. Since a technology is a complex open system that exchanges flows with the external environment, one of the available tools that scientists might find useful to represent it is the bioeconomic and biophysical models [33]. The term bioeconomy has been used in recent years to highlight an economic sector organized around industrial activities to access biomasses [34]. In the energy field, analogously to what happens in living organisms, processes can be seen as catabolic and anabolic reaction subsystems; the anthropological sphere includes catabolic technologies (i.e., those that produce ECs and those that consume them to produce services). Both can be analyzed in terms of sustainability, here NEA is only considered for

the early technologies. Over the years, due to the existence of different stakeholders, the notion of bioeconomy has crystallized in different narratives [33] that revolve around the way in which resources are considered in the production systems. The different narratives have materialized around two concepts of sustainability: *strong sustainability* and *weak sustainability* both applicable to the anthropological sphere and not to the biophysical one [35]. The first is based on Roegen's suggestions [36], who considers the finiteness of resources, the entropic degradation of matter and energy, the pending *Prometheus III*, and recommends a thrifty attitude in the use of resources, envisaging a *de-growth* paradigm. This paradigm postulates the use of resources primarily to cover the vital and most urgent needs, recently returned preponderantly to the attention of economists [37]. The *weak sustainability*, triggered by Solow in 1957 [38] and become very popular later (and still is today!) based on the concept that resource productivity can be increased indefinitely by replacing resources with capital, based on the *unbounded resource productivity* hypothesis. Stiglitz [39] later (1974), modified the Cobb-Duglas production function ( $Q = K^\alpha \cdot L^\beta \cdot R^\gamma$ ) further introducing an external parameter the *rate of technological progress* ( $\lambda$ ) meaning as technological progress the capability of increasing the productivity of resources, by suggesting the following production function:  $Q = e^{\lambda \cdot t} \cdot K^\alpha \cdot L^\beta \cdot R^\gamma$ . He concluded that growth is *permanently* ensured if the *rate of resource augmenting technical progress exceed the population growth rate*, hence the per capita demand [39]. Even if the Stiglitz's hypothesis has not been verified (to our knowledge) for any production sector, probably due to the vagueness of the so-called *technological progress* (replacement of resources, change in the composition of the output, transformation of the production system, etc.), the so-called *Solow/Stiglitz vs. Roegen/Daly controversy* on the use of resources, including energy ones, after more than fifty years, does not seem to diminish of intensity and greatly animates the debate within the ecological economics field. In [40] the Stiglitz's model is criticized concerning  $\lambda$  and the substitution criterion between capital and resources. Because the first is assumed to be independent of other production factors and for the second, substitution methods can be multiple. Germain in [41] considers whether a growth model ignoring the physical constraints with a non-renewable resource, can generate a satisfactory medium-term evolution of the economy. Krysiak [42] has suggested an integrated production and consumption model of that takes into account the conservation/degradation laws of thermodynamics and comes to the conclusion that the Solow/Stiglitz model is unfeasible, while Stiglitz confirms his hypotheses [43].

For EROI calculations, a major problem remains the identification of production factors and the correct operation of them [44]. Moreover, this problem worsens as the complexity of technologies increases. Suggestion is to use Roegen's production function [45] also known as *stocks/flows-funds/services* (SFFS) model. The Roegen's SFFS production model is used to describe complex production systems either in anthropological or in biophysical sphere [46]. Although the SFFS describes the flows of matter and energy, for the present case all the flows are evaluated in energy units including those of matter converted into energy by adequate indices (see below). The SFFS approach is bottom-up, and it serves to bridge the gap between large scale top-down EROI evaluation and facility-scale EC. Additionally, the results of R&D of the specific technological chain can also be included. Thorough bottom-up energy balances include not only evaluating the performance in the transformation of PER/APER into EC (i.e., the efficiency), but also considering the necessary direct and indirect energy flows for its functioning. Fig. 2 shows a general Sankey diagram for non-renewable (Fig. 2a) and renewable-fed (Fig. 2b) EC production; note that besides the energy contained in PER or APER, all the other terms cross the technology boundary and go into the anthropological sphere. Fig. 2 a) shows that for the case of non-renewable PER there is an energy current F, which represents the energy necessary to bring the resource from the natural environment to the plant. For petroleum/natural gas for example, it is the energy necessary for extraction, refining and

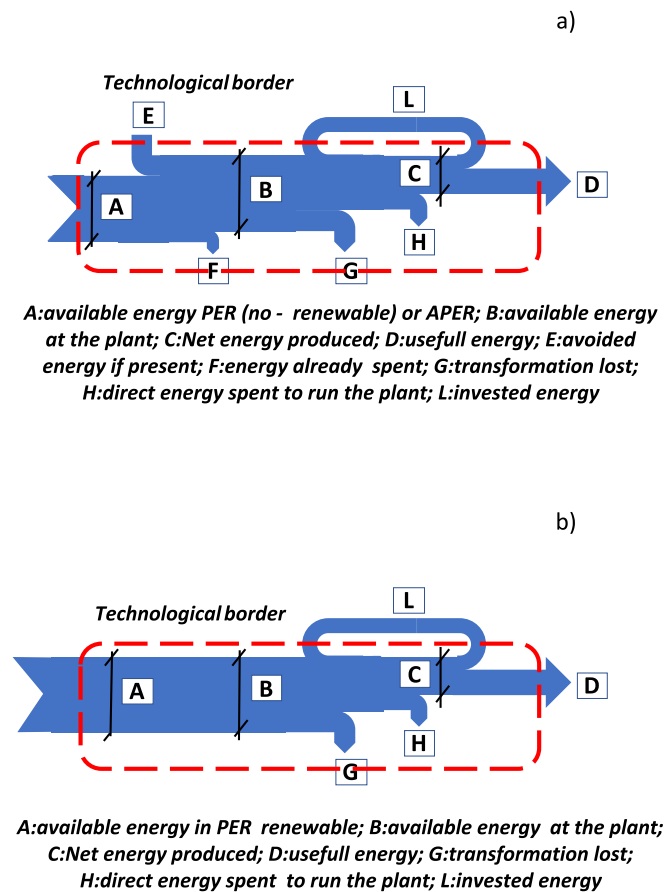

**Fig. 2.** Energy Sankey diagram of for EC production. Energy flows involved in EC production: a) non-renewable Primary Energy Resource (PER) or Anthropological Primary Energy Resource (APER); b) renewable Primary Energy Resource (PER). The dotted red line represents the technology boundary. (For interpretation of the references to colour in this figure legend, the reader is referred to the web version of this article.)

transportation including fugitive losses on route; while, for APER the energy necessary for its collection, transportation and pre-treatment. When APER is waste, there is a positive term energy flow E, accounting for the avoided energy in the anthropological sphere for its correct sanitary disposal. In Fig. 2b) F flow is absent because no EC is spent from the anthropological sphere to bring the resource across the technology boundaries. In other words, there is no expense to make solar radiation hit the PV panel or wind to the turbine etc. The flow L in Fig. 2a) and b) represents the EC which is produced by the plant but which "necessarily" must be invested in the plant itself after a passage in the anthropological sphere. The transformation losses G (Fig. 2) depend on the particular process in accordance with thermodynamics and actual yields. Other key energy flows are required to run the plant as H, and they are sensitive the chosen boundaries of the EC technology production. For example, if the produced carrier is "electricity from a PV panel", this term includes losses to the inverter and transformer. While if the technology in question is "H<sub>2</sub> produced with PV electricity fed electrolyser", the energy costs for the operation of the overall balance of plant (BOP) must be added, which weighs from 20 to 30 % of the electricity supplied [47] (Section 3.3).

Following Roegen [48], the production system is an *open system* governed by thermodynamics laws. *I principle*: the incoming flows are quantitatively the same as the outgoing ones, *II principle*: during the operation of the process, there is a dissipation of both matter and energy in a form that is no longer usable (entropic dissipation) and the production factors are divided into *stocks/flows* and *funds/services*.

Referencing to Fig. 1, it represents a graphical compartmentalization for applying the SFFS model at the technological-anthropological-biophysical spheres intersection. EC technologies have different boundaries, with the anthropological as well as biophysical spheres, through which energy flows are exchanged. Within these analytical barriers, the SFFS model discriminates between incoming stocks/flows PER (either renewable or non-renewable) or APER from biophysical and technological sphere, respectively that are transformed into outgoing stocks/flows streams (EC the desired products) plus the waste stock/flow, the amount of inputs which are not transformed into EC. ECs and wastes go to the anthropological and biophysical sphere, respectively. The other class of production factors funds/services are the share of energy invested in the technology that takes part in the process without being directly transformed into output ECs with no substantial modification of its nature, at short term. Using Daly words [46], stocks are the ingredients (e.g., flour, tomato, salami, etc.) to make a pizza, while funds are the used tools (e.g., table, rolling pin, oven, the pizza maker, etc) to do it.

The use of the funds/services typically involves a specific duration inherently to their physical nature: they also undergo entropic degradation. All the energy terms involved in the funds/services system belong to the anthropological sphere, while the stocks/flows wastes and the dissipative fundsflows (matter and energy), dynamically move from the anthropological sphere to the biophysical one.

To maintain the technology in adequate conditions it is necessary to ensure from the anthropological domain a flow of energy and matter, to cover the dissipative losses (e.g., corrosion, wear, consumption etc.) of the funds including the workforce. Using Roegen's words, funds "must be kept in good working conditions" [49]; however, this requires not only direct energy flows, but also indirect energy to provide a specific quality of matter (embedded energy), which both are subtracted from the anthropological sphere (and hence are no longer useful to cover energy services). These energy flows should be accounted as diverted from the net stock flow production and invested in funds supply production system (Fig. 2). As depicted in Fig. 1, this opens a question of truncation, which require some sort of compromise in the anthropological energy chain level, otherwise the entire productive sector at the World level [49] should be included especially regarding the conversion of labour into energy flows equivalent unit (Section 2.2).

The time dimension is essential, both resource and waste stock flows characterize the productivity of the technology at short time, while funds flows, both dissipative and supply, act on a larger time window (i. e., the entire technology life). This consideration requires the execution of the sustainability analysis over two-time horizons: short and long terms (see Section 3.2).

## 2.2. Definition of model as reference for EROI evaluation

The relative balance of different energy and their quota in SFFS approach depends on the degree of knowledge of the fundamentals and technology implementation. Typically the degree of the Technology Readiness Level (TRL 1–9) is used, where 1 = basic research and 9 = full-scale application. For each TRL degree, the output of the process is given by the combination of the stocks/flows and the funds/services based on the actual efficiency of the process and the magnitude of the fund (i.e., the power). For example, the exploitation of an underground oil reservoir requires a certain number of wells and pumping systems (funds/services) to reach some adequate level of oil production (bbl/day) (output stocks/flows); the electricity output (stocks/flows) of a PV field system, can be increased by capturing a higher flow of solar irradiance using multiple PV modules (funds/services). The conversion efficiency may be increased by the advancement in R&D (more efficient PV module, fracturing, etc.), or changing the nature of funds/services as new processes. Therefore, the use of resources can be anthropogenically controlled if qualitative and quantitative adequate funds/services production factors are given. The semantic dissymmetry between the two

classes of factors stocks/flows and funds/services is thus evident: while the nature of stocks/flows and knowledge of technology, limit the output of the process based on efficiency (in fact, before 1861, first oil well in operation, the oil extraction efficiency was equal to zero), the extension and properties of funds/services govern the production rate (i.e., the power of the system). Then the two factors therefore, are qualitatively different, and are not interchangeable as assumed in the neoclassical theory of production [38]. The formal representation of the Roegen's SFFS for the production of a specific good in term of matter and energy flows, is:

$$F(t) = \int_0^T f \left[ \overbrace{R(t), I(t)}^{\text{input stocks/flows}}; \overbrace{Q(t), W(t)}^{\text{output stocks/flows}}; \overbrace{L(t), K(t), H(t), M(t)}^{\text{funds/services}} \right] dt \quad (1)$$

for:  $R$  energy resources,  $I$  material resources,  $Q$  output products,  $W$  produced wastes,  $L$  Ricardian land,  $K$  capital equipment,  $H$  labour,  $M$  maintenance inputs (matter and energy) to maintain  $K$  efficient, and  $T$  is the technology life. Rearranging the Eq. (1) and for a system using only one PER/APER to produce a specific EC:

$$\overbrace{Q(t), W(t)}^{\text{output stocks/flows}} = \int_0^T f \left[ \overbrace{R(t)}^{\text{input stocks/flows}}; \overbrace{L(t), K(t), H(t), M(t)}^{\text{funds/services}} \right] dt \quad (2)$$

$I(t)$  is neglected because the analysis is energy centred;  $R(t)$  is the quantity of PER/APER that enters to the EC production system whose unit of measurement depends on the chosen reference base, for example MJ/m<sup>2</sup>, MJ/year, bbl/unit time, kWh/MJ, MJ/mol, etc. The distinction between APER and PER depends on the resources: for example, while the methane used in power plants and the waste valorised through Waste-to-Energy (WtE) processes are APER, the wind or the solar irradiance are PER. The  $R(t)$  input stock/flow is considered in energy terms, although its conversion may also involve matter transformations (e.g., coal, oil, gas, biomass) where it is converted into CO, CO<sub>2</sub>, NO<sub>x</sub> and other compounds. For immaterial PER (e.g., solar, wind, hydro, marine waves, etc.) the matter does not undergo any changes.  $Q(t)$  is the product EC which should be computed in consistent energy units as for example MJ per unit of mass, surface, or kWh.  $W(t)$  is the outgoing energy flow not converted:  $W(t) = R(t) - Q(t)$ , whose nature can be thermal (in most cases) or chemical type (e.g., non-biologically degraded compounds in a fermentation process, bioethanol production, Anaerobic Digestion).  $W(t)$  indicates the output energy stocks/flows which is no longer exploitable by the technology under analysis, other technologies might be able to further transform a share of  $W(t)$  into  $Q(t)$ . For example, a power plant that produces electricity using methane, the sustainability analysis could be evaluated by considering the electricity alone as useful energy or electricity&heat as  $Q(t)$  in the case of "cogeneration" plants. The embedded energy in the incoming matter  $M(t)$ , as the required share to keep the funds in adequate conditions, will analysed in detail in Section 3.1.  $T$  is the overall life of the technology, i.e., the time required for its construction/assembly plus the operation time and decommissioning/closure and in addition, the time required for the wastes treatment. This consideration seeks to indicate that each EC process is unique, due to the patterns of stocks/flows and to the magnitude of funds/services. In addition, the degree and extension on which funds/services are used must be considered at each TRL point value. Accordingly, the traditional paradigms of unbounded resources productivity [38], the elasticities of substitution and the learning curves [39] do not hold valid for the SFFS represented by Eq. (2) since stocks/flows and funds/services are not interchangeable on the scale of facilities. The SFFS model presents a higher complexity, compared to the of neoclassic production model, Eq. (2) is suitable to analyse a specific EC production systems either at microlevel

(facility scale), or at macrolevel as the aggregation of different EC technologies. In Section 3.2, a methodology will be proposed to simplify the modelling of complex energy systems, and it will be exemplified for the electricity production.

Once the SFFS has been applied to a EC production technology, by drawing proper system boundaries and identifying and labelling productions factors as *stocks/flows* and *funds/services*, it is possible to evaluate the energy performance. Using the NEA approach EC process are analysed in terms of the return of energy into the anthropological sphere to cover energy services. Hence a reformulation of EROI is proposed, taking into account Eq. (2) as follows:

$$EROI = \frac{\overbrace{Q(t)}^{\text{output stocks/flows}}}{\underbrace{K(t), H(t), M(t)}_{\text{funds services}}} \quad (3)$$

more specifically, a useful formulation of Eq. (3) is:

$$EROI = \frac{\text{Net energy of stocks/flows}}{\text{Energy (invested) in funds/services}}; \quad EROI = \frac{EC_{net}}{EC_{inv}} \quad (4)$$

The *net* term means that the quantity of  $Q(t)$  arriving in the anthropological sphere minus all the energy flows spent (if present) from this sphere to convert the input *stock/flow*  $R(t)$  from the biophysical sphere into adequate EC form, which is no longer available to cover any type of energy service. Therefore, differently from what is reported in [50], *net* does not mean energy balance at the plant, but rather done from the plant to the anthropological sphere,  $R(t)$  is not computed as energy expended in the denominator, because it is a *stock*; considering it as expense, would lead to  $EROI < 1$ . In more operational terms Eq. (4) can be rewritten as:

$$EC_{net} = EC_{prod} - EC_{dir} - EC_{already\ spent} + EC_{avoided\ energy}$$

$$EC_{inv} = \sum_{i=1}^n EC_{inv,i} \quad (5)$$

hence wastes and entropic dissipative flows, which are no longer usable, are not considered in Eq. (5), because they belong to the biophysical sphere, even if materially they make their devastating effects in the anthropological sphere, this in accordance with the economic concept of externality. In the following the meaning of each term of Eq. (5) is clarified.

$EC_{net}$  is the net energy produced by the system discounting the energy spent to operate the technology and that to obtain the input *stock/flows* in adequate EC quality at the entrance, if any. For example, the bioalcohol fuel production needs to have corn grains at the entrance of the plant, and this requires an energy expenditure which must be subtracted from the energy incorporated in the produced biofuel.

$EC_{prod}$  is the EC produced by the system, discounting the actual efficiency of the system i.e., the *accessible* energy.

$EC_{dir}$  is the direct EC expended (heat and/or electricity) to run the system to produce  $EC_{prod}$ , hence, subtracted from the anthropological sphere (e.g., the electricity consumption of a thermoelectric plant for auxiliaries or the energy necessary to heat an anaerobic reactor till the working temperature). Care must be taken in the calculation of  $EC_{dir}$  being energy subtracted at the anthropological level, it is necessary to consider the efficiencies for supplying both thermal and electrical energy to the point of use. In the case of thermal energy it is enough to consider the combustion plus heat exchanger efficiencies, vice versa particular attention must be paid to the evaluation of electrical energy. If the electricity is produced *in loco*, it can be assessed by considering the consumption of the resource used (gas, coal, other). Particular attention should be paid to the case in which electricity is taken from the national grid, which involves knowledge of the global efficiency of the electricity system. In the case of Italy, in 2017 the system efficiency was 0.64, i.e.,

for 1.000 kWh at the consumer 1.564 kWh of non-renewable resources was spent, for renewables only the quota of electricity transmission and distribution losses [51] was accounted. Since  $EC_{dir}$  is a *stock/flow* (potentially it could be the EC produced, as the self electricity consumption of a thermal power plant) but not available to cover energy services it is considered in terms of GER or CED for EC obtained from renewable and non-renewable resources, respectively (see Section 3.1).

$EC_{already\ spent}$  is the EC spent to have the *stock/flow* to the technology boundary, which is the sum of the all energies spent to extract or produce the *stock/flow* plus the energy share for transportation and losses if any (as for example in the case of the methane the fugitive quota in the pipeline or during its use).  $EC_{already\ spent}$  is subtracted to the produced *stocks/flows* as it is no longer available to cover energy service. For example if an APER is used, (as for example corn feeding a fermentation process to produce bioethanol) the produced EC (under form of bioethanol) must be discounted by the energy spent in the anthropological domain to produce corn (sowing, fertilization, harvesting etc.) and for the transportation of the grains from crop fields to the bioethanol production plant. In the case of electricity generation by fossils, the ECs spent for extraction, purification, and transportation of fossil resources up to the gate of thermal power plant must be subtracted. As for electricity from nuclear sources, all the necessary energy expenditure to transform radioactive ores into nuclear fuel rods must be considered in the  $EC_{already\ spent}$  share. Vice versa PV electricity, as other technologies using renewables, the produced electricity is within the technology boundary without subtracting EC from the anthropological sphere: there is no energy expenditure to produce renewable resources as *stock/flows* to feed the technologies. The only expenses are those incurred for the *funds/services*, i.e., to produce the PV panels or the hydroelectric power plants. This approach for the EROI evaluation overcomes the discrepancies between calculation methods. It does not require energy equivalence factors for the renewable resources, because only EC produced enters in the calculation, i.e., electricity in the case of PV panel or thermal energy in the case of thermal solar technologies. Fig. 3 shows examples of  $EC_{net}$  numerator calculation of EROI, for 4 typical technologies, to clarify the applicability of Eq. (5) for PER and APER. Attention should also be paid to the technology for the production of  $H_2$  (Fig. 3 c) by Steam Methane Reformer (SMR) in which methane is used both as a chemical and as a fuel to heat the reactors till the working temperatures. In the case of  $CH_4$  as chemical, the GER must be used because the “feedstock” (i.e., lower heating value or LHV, Section 3.1) energy of  $CH_4$  is accounted by efficiency of chemical reaction together with the energy spent to have the methane at the plant to produce  $H_2$ , while in the use of  $CH_4$  as fuel, the CED must be accounted (Section 3.1).

$EC_{avoided\ energy}$  is the “saved” energy if the resource, as in the case of wastes, is not used to produce EC and must be treated to make it environmentally acceptable.

$EC_{inv}$  is the totality of the invested EC in the specific technology (*funds/services*), as further detailed in Table 1, measured in the same unit of the numerator.  $EC_{chem}$  is the energy that is spent elsewhere in world to produce the chemicals required by the process, if they are needed:  $EC_{chem} = \sum CED_{chem,i} \cdot m_{chem,i}$ , similarly  $EC_{mat} = \sum CED_{mat,i} \cdot m_{mat,i}$  for the construction of components of the technology, (for the specific contribution CED in MJ/kg see Section 3.1).  $EC_{constr}$  and  $EC_{decom}$  are similar as they represent the energy consumed for construction and for dismantling the plant, respectively. Their evaluation may be achieved using the following:  $EC_{constr} = (EC_{chem,c} + EC_{mat,c} + EC_{dir,c} + EC_{lab,c}) \cdot \sigma$  and  $EC_{decom} = (EC_{chem,d} + EC_{mat,d} + EC_{dir,d} + EC_{lab,d}) \cdot \tau$ . As a first approximation  $\sigma$  and  $\tau$  can be considered in the 20–30 % range, or can be evaluated on a case-by-case basis; subscript *c* and *d* stand for construction and for dismantling, respectively.  $EC_{ind\ dir}$  considers the quantity of energy invested in the devices to produce and use the  $EC_{dir}$  it can be evaluated similarly to  $EC_{mat}$ .  $EC_{maint}$  estimates the energy consumed in maintenance operations, and its evaluation strongly depends on the indirect energy for materials, during the working life of the technology. In fact, many parts of the plant could be repaired or replaced because of wear,

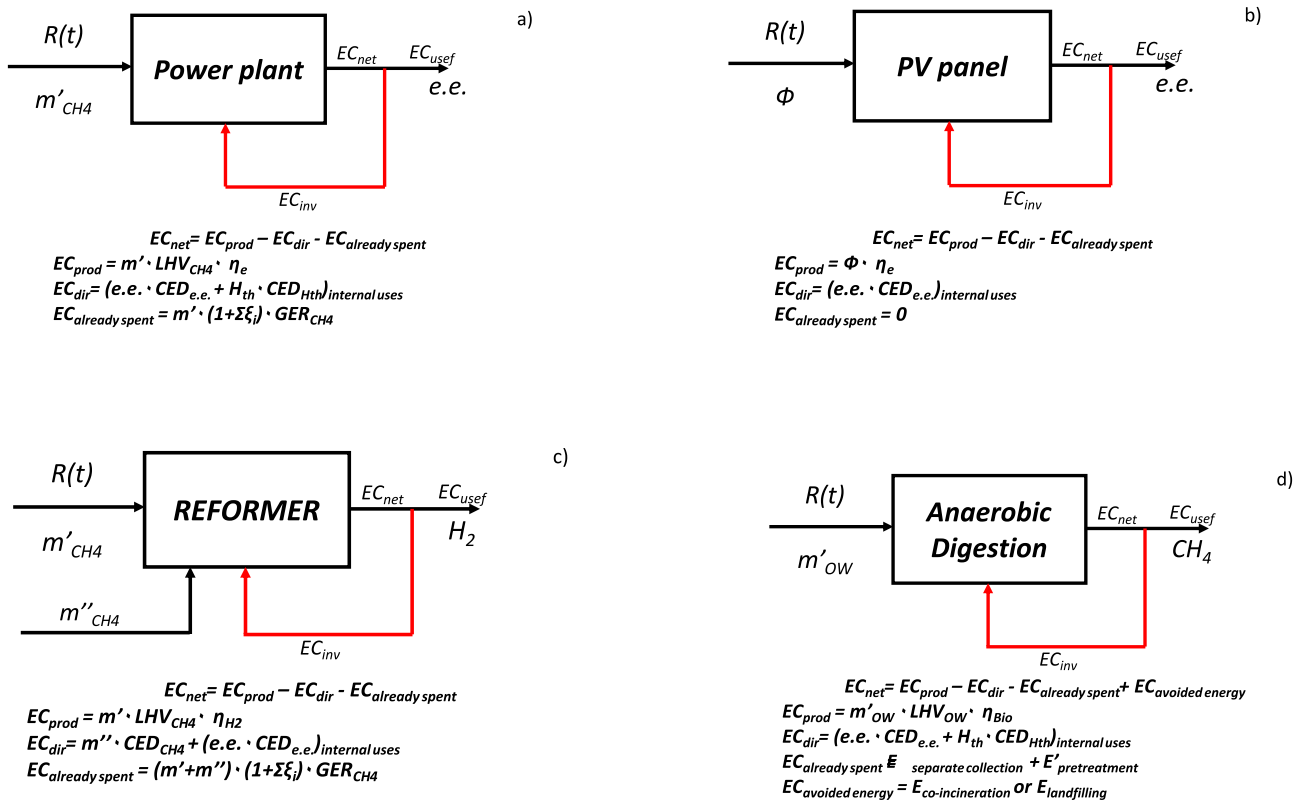

**Fig. 3. Some examples of  $EC_{net}$  evaluation for different technologies.** a) Power plant using methane:  $m'$  input flow rate of methane;  $LHV_{CH_4}$  low heating value of methane;  $\eta_e$  electrical conversion efficiency of the plant;  $e.e.$  internal uses of electrical energy;  $CED_{e.e.}$  cumulative energy demand of  $e.e.$ ;  $H_{th}$  thermal internal heating necessities covered by fossils;  $CED_{Hth}$  cumulative energy demand of fossils used;  $\sum \xi_i$  summation of all methane losses in tube, compressors, valves, etc.;  $GER_{CH_4}$  global energy requirements of methane. b) PV panel producing electricity:  $\Phi$  input flow rate of solar radiation;  $\eta_e$  electrical conversion efficiency of PV;  $e.e.$  internal uses of electrical energy inverter/converter. c) Reformer plant for  $H_2$  production:  $m'$  input flow rate of methane as reactant;  $\eta_{H_2}$  chemical conversion efficiency of methane into hydrogen;  $m''$  input flow rate of methane as heating agent;  $e.e.$  internal uses of electrical energy;  $\sum \xi_i$  summation of all methane losses in tube, compressors, valves, etc. for  $m' + m''$ ;  $CED_{CH_4}$  cumulative energy demand of  $CH_4$ ; d) Anaerobic Digestion:  $m'_{OW}$  input flow rate of Organic Wastes (OW);  $\eta_{Bio}$  bioenergy conversion efficiency of the plant;  $E_{separate\ collection}$  energy spent for the separate collection of OW;  $E'_{pretreatment}$  energy spent for the pretreatment of OW;  $E_{co-incineration}$  or  $E_{landfilling}$  energy saved for the treatment of OW.

**Table 1**

Components of the invested energy (*funds/flows*) from the anthropological sphere.

$E_{inv,i}$	Description
1) $EC_{chem}$	Indirect energy carrier used to produce the <i>chemicals</i> of the process
2) $EC_{mat}$	Indirect energy carrier used to produce the <i>materials</i> of the process
3) $EC_{constr}$	Indirect energy carrier used for <i>construction</i> purposes
4) $EC_{decom}$	Indirect energy carrier used for <i>decommissioning</i> purposes
5) $EC_{labour}$	Indirect energy carrier used to sustain the <i>human labour</i>
6) $EC_{maint}$	Indirect energy carrier used for <i>maintenance</i> purposes
7) $EC_{amort}$	Indirect energy carrier allocated for the <i>amortization</i> of materials and chemicals for the facility replacement
8) $EC_{ind\ dir}$	Indirect energy carrier embedded in the devices to produce the <i>direct energy</i> for the process

tear or damage, it could be calculated in first approximation as  $EC_{maint} = EC_{mat} \cdot \zeta$  where  $\zeta$  is a percentage that can be assessed by knowing the history of similar plants or by knowing the schedule of maintenance interventions.

By bringing attention to the workforce and considering that it is a *fund* since it is not transformed into the product (EC), its conversion into energy units is particularly difficult; for this reason, in most of the studies on EROI evaluation is neglected. A solution is suggested in [52], here a brief consideration is reported. The quantity of EC invested in labour can be divided into two terms: *endosomatic* energy, biological support (c. 1,700 kcal/day worker) plus that EC necessary to produce and supply such energy from the field to the table, and *exosomatic*

energy, linked to daily activity of the worker outside the production system (use of household appliances, clothes, energy cost of transportation from home to factory, etc.) this term is very difficult to assess and is closely linked to wages and therefore to the geopolitical context in which technology has dropped. The suggestion is to consider only the contribution of endosomatic energy including that necessary for the production, transport, storage, and preparation of food, [53] the number of daily meals and the number of workers involved in the technology:  $EC_{labour} \approx EC_{food} = GER_{meal} \cdot 2 \cdot n_{workers} \cdot h_{work}$ , were  $n_{workers}$  and  $h_{work}$  are the number of workers and hours worked, respectively. This approach restricts the energy needs of the workforce only to working activities, which in the perspective of comparing different energy technologies seems to be an adequate criterion. In addition, it is not affected by the geopolitical location of the technological process: a gas thermal power plant requires the same number of workers for operation in China or in Finland, the only difference is given by the diet followed, which is known within a certain degree of uncertainty [53].

Another important term, which is fundamental for the sustainability assessment of EC producing technology is the necessity to assure its *viability*. Similar to living organisms which assure the continuity of the species by generating offspring, it is important to consider among *funds/services* producing factors the term  $EC_{amort}$  as amortization energy quota. It considers of storing somewhere in the world, the energy to reproduce the materials structure, chemicals and to assembly the technology. This is similar to the economic approach, where the monetary amortization quota ensures the reproduction of the invested capital. Following N.G. Roegen [45], this term is utmost of importance to assure not only the

technology to be *feasible* but its *viability*. Since at time  $T$  the demand for energy continues to exist, given the necessity to cover the energy services, hence Eq. (4) with particular reference to  $EC_{amorb}$  can be regarded as a *strong sustainability* index able to score different technologies towards energy sustainability.

The calculation of the EROI, following Eqs. (4) (5), avails of the classification of production factors *stock/flows* and *fund/services* within the outlined boundaries, corresponding to usual terminology of NEA *net energy obtained* (numerator) and *energy invested* (denominator). The SFFS-based approach along with the use of well-defined functional unit specifically for each technology, permits to compare the performance of different choices to cover similar energy services. For example, in the case of indoor air conditioning, it is possible to choose between centralized conditioning plant that burns a fossil to heat water that is circulated, or a heat pump technology, or even a bio-architecture approach with adequate glass surfaces and the use of adequate insulating materials. The choice must be made considering the technology that presents an higher EROI.

### 3. Results and discussion

#### 3.1. On the evaluation of the energy embedded in the matter

The greatest criticality in the application of the NEA of a technology is the evaluation of the energy incorporated in the materials. The direct estimation of these terms is extremely difficult as it would be necessary to analyze the production cycle or, in some cases, to compare several production cycles to evaluate energy costs. Therefore it is common practice to perform this estimate by accessing the so-called “secondary data” (i.e., data reported in databases that are usually used for LCA analysis). To apply Eqs. (4) (5) it is necessary to convert into energy unit all the matter crossing the *gate* of the technology (i.e., the boundary between the anthropological and technological spheres, ref. Fig. 1). The conversion regards  $K$  and  $M$  (*funds/flows*), but also the entering *stocks/flows* if it is the case (as occurs in the use of fossil or nuclear). While there is no energy expenditure from the anthropological sphere in the case of renewables, adversely energy is spent to extract, purify and transport the methane [54] that is present in natural gas to use as *stock/flow* in power plant. The same figure applies in the case of such APER as seen for the corn feeding a process to produced biofuel as bioethanol. For energy accounting procedures to produce goods, commodities, or services the most widely used terms are GER and CED. GER represents the sum of all the energy expenditures at anthropological sphere, while CED is the total energy expenditures at the anthropological sphere plus the depletion of energy resource at biophysical spheres, hence the total energy that must be extracted from the environment to deliver a good, commodities or to support a service. In fact, of summing the energy input to each of stage of production, the depletion of resources is accounted by means of the LHV of the resource, called in LCA terminology, *feedstock* energy, this in the case of non-renewable resources; unfortunately this is also done for renewable one, as reported in data base [55] but opening up a big question of what is the LHV of a renewable resource.

Initial LCA studies tended to focus on the energy impact using either GER or CED to account for the direct and indirect energy invested in the entire process chain. Nowadays, the utilization of common databases [55] and software [56] have increased the chances to produce comparable results. However, data quality plays an important role as well as the type of data selected for the analysis, *primary* by direct investigation on site or from the literature survey and *secondary* taken from existing databases. Table 2 shows some methodologies used to evaluate the energy footprint indicators in LCA analysis.

As it can be seen from Table 2, for each approach the energy indicator has a different meaning, hence not all impact methods in LCA studies evaluate the energy footprint in the same way. In addition, most of the methods also include in the index the *feedstock* energy. In the case of renewable resources, efforts are made to evaluate the thermal

**Table 2**  
General LCA energy indicators.

Method	Energy Indicators	Units	Feedstock energy
CML-IA	■ Abiotic depletion (fossil fuels)	MJ	Considered
Environmental Footprint (EF)	■ Resource use, energy carriers	MJ	Considered
Environmental Prices	■ Fossil depletion	Kg oil eq	Considered
EDP	■ Abiotic depletion, fossil fuels	MJ	Considered
IMPACT 2002+	■ Non-renewable energy	MJ primary	Considered
ReCiPe 2016	■ Fossil resource scarcity	USD2013	n.a.
BEES	■ Natural resource depletion	MJ surplus	Not considered
TRACI	■ Fossil fuel depletion	MJ surplus	n.a.
Cumulative Energy Demand (CED)	■ Total non-renewable (fossil, nuclear, biomass) Renewable (biomass, wind, solar, geothermal, water)	MJ (or MJ eq)	Considered
Eco-indicator	■ Energy resources	MJ LHV	Considered

equivalents of renewable resources [57]. In the Author’s opinion, this approach is questionable, first of all because the equivalence is possible only under certain technological conditions (e.g., production of equivalent electricity or equivalent thermal energy, etc.), and mainly since the use of renewables resources does not impoverish the biophysical sphere, therefore it is not clear why to take into account as expended energy. Lastly, it is not of neglecting the question of which unit of measurement should be used to compare the energy equivalent of renewables vs. fossils, which remains unsolved question [58]. The present method for EROI evaluation does not need to evaluate the equivalent of renewable PER because only the conversion of the renewable resources as electricity or heat, generated by the technology under analysis, is computed at the numerator of Eq. (5).

Table 3 shows some CED and GER values extracted from two frequently used software *SimaPro* and *OpenLCA*. A first consideration (Table 3) concerns the quality of the accounted energy, in fact in the second column (*OpenLCA*) only fossil-type energy is computed. A second aspect regard the numerical values that in some cases is significantly different between one database and another. Finally, some critical issues concern the energy contributions taken into consideration. Indeed, comparing the data of Table 3 to produce bioethanol the contribution of renewables seems to be enormous. This suggests that solar energy for the growth of the cereal was also accounted; which is not clear. Luckily, from Table 3 there is no doubt about the energy value of materials and chemicals: the GER coincides with the CED.

The distinction between GER and CED is of particular importance in NEA analysis in which the object is the quantification of how effective a technology is for supplying useful EC. Energy accounting in NEA requires special attention regarding the use of GER or CED data reported through databases, since the *feedstock* energy can be included or not (see Fig. 3) together with the other anthropogenic energy expenditures to produce the EC. If both terms are included in the value reported in data base CED, to have the GER, the *feedstock* (LHV) energy should be subtracted because it does not deplete energy at anthropogenic level, but only in the biophysical sphere. If there is no doubt about the use of the CED for the evaluation of the denominator of Eq. (4), the evaluation of  $EC_{net}$  needs clarification. As shown in Fig. 3, the evaluation of  $EC_{net}$  Eq. (5), means do the balance of the *stocks/flows* between the technology and the anthropological sphere. As seen in Fig. 3, the production of EC considers the GER in the calculation of  $EC_{already\ spent}$  at the numerator,

**Table 3**  
CED and GER for some materials & chemicals and Energy Carriers (EC).

		Cumulative Energy Demand (CED) <sup>a)</sup>	Resource use, fossil (total) <sup>b)</sup>	LHV	Gross Energy Requirement (GER) Anthropogenic Energy*	Unit
<i>Energy Carriers (EC)</i>	Diesel, at refinery	43.80	42.87	36.2	7.60	MJ/L
	Soy biodiesel, at plant	8.31	n.d.	32.6	8.30	MJ/kg
	Gasoline, at refinery	39.10	37.88	32.2	6.90	MJ/L
	Natural Gas processed, at plant	38.00	38.20	33.4	4.60	MJ/ Nm <sup>3</sup>
	LPG, at refinery	27.30	29.00	23.9	3.40	MJ/L
	Anthracite coal, at mine	47.60	28.03 <sup>c)</sup>	30.1	17.50	MJ/kg
	Biogas from manure, at plant	5.82	n.d.	22	5.82	MJ/ Nm <sup>3</sup>
	Synthetic Gas, from wood, at gasifier plant	9.28	n.d.	16	9.28	MJ/ Nm <sup>3</sup>
	Ethanol, from switchgrass, biochemical plant	85.20	43.09 <sup>d)</sup>	17.0	68.20	MJ/kg
	<i>Assorted materials and chemicals</i>	Drinking water, from groundwater, at plant	2.41E-03	7.8E-03 <sup>e)</sup>	–	2.41E-03
Drinking water, from surface water, at plant		3.37E-03	n.d.	–	3.37E-03	MJ/kg
Portland cement, at plant		5.17	3.24	–	5.17	MJ/kg
NaOH, production mix, at plant		15.90	12.22	–	15.90	MJ/kg
Hydrochloric acid, at plant		23.39	11.79	–	23.39	MJ/kg
Iron and steel, production mix		10.39	n.d.	–	10.39	MJ/kg
Steel, engineering steel, at plant		17.84	n.d.	–	17.84	MJ/kg

\*Evaluated considering the values reported in *SimaPro* of the first column less LHV.

a) From *SimaPro 9.1.1.1*, Method *Cumulative Energy Demand (LHV) 1.0*, using the *USLCI*, *ELCD*, *Ecoinvent 3.0* and *Industry Data 2.0* databases.

b) From *OpenLCA 1.10.3*, Method *Environmental Footprint (Mid-point indicator)*, using the *EF secondary data 2019* database (i.e., the chosen items correspond to either EU 27 or EU28+3 datasets).

c) OpenLCA data represents the item *hard coal, consumption mix*.

d) OpenLCA data represents the item *ethanol, production mix, at plant*.

e) OpenLCA data represents the item *tap water, technology mix, at user*.

f) Reference year of the Italian mix grid 2002.

g) Reference year of the Italian mix IEA 2012.

because the LHV is considered by the transformation efficiency of the technology, in addition the energy spent to bring the resource to the plant (if any) must be accounted. This means to consider the quantities of EC subtracted from the anthropological sphere and used to “extract” the energy from the biophysical reservoir till to the technology (refers to Fig. 3 a, c, d). The *feedstock* energy is not spent, it still is present in the input *stock/flow*, in fact, it is transformed into EC by technology itself. Considering the CED in *EC<sub>already spent</sub>* would mean counting LHV twice; in other words, the GER is one of the components of the term of *EC<sub>already spent</sub>*.

The evaluation of *EC<sub>dir</sub>* involves the use of the value of the CED, because the LHV is also subtracted from the anthropological domain and therefore no longer available to cover others energy services. In fact, it covers the service of “making the technology works” and therefore subtracted from the flow of EC produced.

As can be seen from Fig. 3, the use of the CED or GER is univocally determined if the flows of ECs within the technology under consideration are known. For example, in the case of the CH<sub>4</sub> reforming (refers to Fig. 3 c), methane is transformed into another EC that is hydrogen. In SMR technology, methane is used both as a chemical EC, (a *stock/flow* which is converted into H<sub>2</sub>), and as a service EC, (to bring the conversion reactor till the working temperature), hence spending also the LHV, no available for any other operation. This last consideration highlights that to perform a correct EROI evaluation of a certain technology it is utmost of importance to acquire all the technological information about it.

Another consideration regards the use of other available methods to evaluate the energy footprint (some reported in Table 2), which do not serve to the purposes of EROI evaluation of a technology since they use some special indicators such as: the depletion of resources through the increase in the energy or monetary costs of future extractions, etc. These are certainly important indicators, but they are not useful for the energy

sustainability analysis.

Particular attention must be paid in the evaluation of the CED and GER of a particular EC as electricity, which is at the origin of many inconsistencies in the energy sustainability analysis of electrical systems [29]. Electricity can be used either as a *stocks/flows* as for example in the case of the production of H<sub>2</sub> by electrolysis, or spent as *direct energy* to cover all the electrical needs of a process or service. In the first case GER must be accounted in the evaluation of the *EC<sub>already spent</sub>*, as occurs for all other resources used to produce such EC because the quota of *feedstock* of PER/APER which becomes electricity is still “embedded” in it, and can be converted into another form of EC. While in the second case, the CED must be considered, because in this case, it is the total energy spent at the anthropological level, including the *feedstock* spent to obtain the electricity, which is no longer available neither to produce another EC nor to cover other energy services.

Therefore, the knowledge of the CED and GER values of electricity is of fundamental importance. Unfortunately, in the available databases for the electricity only the value of the CED is reported. Table 4 shows some examples. Considering that is very difficult to evaluate the GER of the electrical network system (nation) from database, the only way is to make the analysis of such specific electrical system. This means that it is necessary to evaluate the actual total contribution of non-renewable resources spent to produce the electricity, to estimate an equivalent LHV considering only non-renewable resources and to subtract it from the CED to obtain the GER. Table 4 reports the results obtained by a detailed analysis (which is not the purpose of this work) of the Italian electricity system [51], from it one can see that to obtain 1 kWh of electricity by natural gas, 6.3 MJ of thermal energy of CH<sub>4</sub> are required (hence not 3.6 MJ, which is the thermodynamics equivalent of kWh). Obviously renewable resources do not give contributions to the value of the CED, they are affected only by the energy expenditures of the

**Table 4**  
Comparison of CED of electricity by different resources for the Italian electricity mix at 2017 year with value present in data base.

Electrical Energy technology production	CED <sup>a)</sup> [MJ/kWh]	CED <sup>a)</sup> [MJ/kWh]	GER <sup>a)</sup> [MJ/kWh]	Fraction Mix <sup>a)</sup> [%]	CED [MJ/kWh]	GER [MJ/kWh]
Electricity, natural gas, at power plant	11.40	6.40	0.05	47.09	3.01	0.022
Electricity, lignite coal, at power plant	20.50					
Electricity, bituminous coal, at power plant	14.10					
Electricity, anthracite coal, at power plant	17.10	9.40	0.12	16.22 <sup>b)</sup>	1.52	0.019
Electricity from hydroelectric power plants (< 1 kV)	4.64		0.11	13.21 <sup>c)</sup>		0.015
Electricity from hydroelectric power plants (230 V)	4.27					
Electricity, residual fuel oil, at power plant	12.60					
Electricity, diesel, at power plant	14.60					
Electricity with photovoltaics (low voltage)	5.19		1.18	8.45 <sup>d)</sup>		0.100
Electricity from onshore and offshore wind farms	0.13		0.34	6.18 <sup>e)</sup>		0.021
Bioelectricity (biogas + landfill + incineration) <sup>a)</sup>	–	1.60	0.59	6.81	0.11	0.040
Electricity geothermal <sup>a)</sup>			0.13	2.05		0.003
Italian MIX at 2017 <sup>a)</sup>				100.00	4.65	0.219

<sup>a)</sup> From SimaPro v.9.1.1.1.

a) Italian mix, in S. Colombatto, *Analisi energetica del Sistema elettrico nazionale e valutazione delle emissioni di CO<sub>2</sub> dirette ed indirette della filiera elettrica italiana*. Master Thesis, Politecnico di Torino (Italy), a.y. 2018/2019.

b) Combination of different types of coal, details in <sup>a)</sup>.

c) Italian hydroelectric mix: > 10 MW 84.7 %, (1–10) MW 11.6 %, < 1 MW 3.7 %, details in <sup>a)</sup>.

d) Photovoltaic systems combinations of: micrystalline 21%, polycrystalline 73%, amorphous 6%, power from 3 to 5000 kW, details in <sup>a)</sup>.

e) Only onshore wind farms, Italian mix: < 1 MW 3.9%, > 1 MW 96.1%, details in <sup>a)</sup>.

technology for their use, which contributes to the GER. Finally, it should be noted that the CED depends on the percentage of use of non-renewable resources within the electricity production system, hence it depends on the political and economical decision to use renewable resource, while the GER depends only on the technological efficiency in the production of electricity (i.e., efficiency technological improvements). Over time CED and GER have different trajectories, in fact, for the Italian system, the first varied of 56% and the second only of 15%, respectively in 15 years (ref. to Table 5).

Finally, particular care must be paid in the use of data from different databases; suggestion is to use the same database to compare different technologies to eliminate incorrect evaluations and distortions, in this

**Table 5**  
CED and GER variation over time of the Italian electrical system.

Year	2002	2012	2017
(CED) Electricity system medium voltage, consumption mix (IT)	10.55 <sup>a)</sup> [MJ/kWh]	6.62 <sup>b)</sup> [MJ/kWh]	4.65 <sup>c)</sup> [MJ/kWh]
(GER) Electricity system medium voltage, (IT mix)	0.258 <sup>d)</sup> [MJ/kWh]	0.232 <sup>d)</sup> [MJ/kWh]	0.219 <sup>d)</sup> [MJ/kWh]

<sup>a)</sup> Reference year of the Italian mix grid 2002, *SimaPro* 9.1.1.1, Method Cumulative Energy Demand (LHV) 1.0, using the USLCI, ELCD, *Ecoinvent* 3 and *Industry Data 2.0* databases.

<sup>b)</sup> Reference year of the Italian mix; from <https://www.iea.org/reports/world-energy-outlook-2012>.

<sup>c)</sup> Our estimate, See Table 4.

<sup>d)</sup> In S. Colombatto, *Analisi energetica del Sistema elettrico nazionale e valutazione delle emissioni di CO<sub>2</sub> dirette ed indirette della filiera elettrica italiana*. Master Thesis, Politecnico di Torino (Italy), a.y. 2018/2019.

way the comparison of different technologies is more consistent as performed in the same uncertainty range. Lastly, it is important to remember together with the use of the same database, to apply the *same method* to have a reliable and effective comparison of different technologies.

### 3.2. On the use of the model for the energy technologies development

For a viable development of energy technologies, attention must be paid to the two classes of production factors in SFFS. While the optimization and continuous improvement of *stocks/flows* efficiency conversion through R&D tends to get most of the attention of the researchers, the requirement of *funds/services* to keep them in perfect working conditions, does not receive much attention. Consideration should be paid to energy expenditure for the formulation of new materials (e.g., catalysts) for nascent process, which could require more energy per unit of produced EC. However, understanding that efforts to improve the efficiency conversion of *stocks/flows* is subjected to the thermodynamic limits the system cannot be viable nor sustainable if new materials or new catalysts, significantly increase the *funds/services* energy required (EROI < 1). The suggestion is in some situations to accept low efficiency conversion of *stocks/flows* but at low *funds/services* energy investment (i.e., less energy expensive materials), hence leading to increase EROI, understanding that technologies with lower EROI depress society as a whole [59].

The SFFS model is useful in the development of emerging energy technologies that are in the infancy state (TRL < 3) abundantly candidate in the present time. In these cases, the application of Eq. (5) is extremely difficult if not impossible, as all the terms that make up the energy *invested* are not known with a sufficient degree of reliability. For instance, the *maintenance* term of the *funds/services* as well as the technology life for many situation are unknown. In these cases, it is important to carry out a short-term sustainability analysis to scree different technologies. To this end and recalling the similarity between energy and economic analysis, the Energy Sustainability Index (ESI) was introduced, which is the equivalent of economic *cash flow* [60]. ESI is the relationship between only *stocks/flows* of different signs that characterize the technology under analysis:

$$ESI = \frac{EC_{prod} - EC_{already\ spent} + EC_{avoided\ energy}}{EC_{dir}} \quad (6)$$

it relates all the technological contributions i.e., the *relative* (to the technology) net energy to the direct energy required by the technology itself. ESI evaluates the energy performance on a typical operative condition, so only short-term information is collected. It is not able to give information about the performance of the technology over its technology life, rather, provides a picture at some fixed time point for

the specific technology development. Attention must be paid for the ESI evaluation for technologies using renewable PER, owing the biophysical environmental effects the performance of the system, therefore in these cases, assessments must be made in an adequate time frame due to the cyclical nature of resources (i.e., about 1 year is accepted). Only those technologies that have an  $ESI > 1$  merit to be implemented and amenable to a complete analysis by means of EROI evaluation. Conversely, technologies with  $ESI < 1$  require an in-depth study to reduce or limit the expenses of energy otherwise they must be abandoned. In these situations, the use of the ESI and EROI metrics demonstrates their effectiveness and serves as heuristics for intrinsic technology performances and selection among different technologies having  $TRL < 3$ .

One of the critical aspects of sustainable EC technologies development is the scale problem. The EROI metric can also be a useful parameter to determine the pathways towards efficient scale-down performing tests at R&D in research facilities. In addition as technologies present a scale-dependent *stocks/flows* efficiency conversion, additionally scale-up support can also be rationalized following the guide of the EROI as heuristics [52].

As regards the evaluation of the energy sustainability of systems made up of different combinations of technologies in series and parallel, which use different resources (renewable and non-renewable), the evaluation of the EROI of the system is an effective tool in forecasting the useful EC that the system produces. To this aim, it is important to remark, that EROI is a technology marker able to express the *useful* EC, which binds technology-specific *stocks/flows* and *funds/services*:

$$EC_{usef} = EC_{net} - EC_{inv}$$

$$EC_{usef} = EC_{net} \left( 1 - \frac{1}{EROI} \right) \quad (7)$$

$$EC_{net} = EC_{usef} \left( \frac{EROI}{EROI - 1} \right)$$

where  $EROI^{-1}$  represents the percentage of the energy produced, which conceptually goes back crossing the anthropological sphere to the technological for the energy necessities of the technology itself (e.g.,  $EROI = 5$  the 20% of CE produced goes back to the technology).

The evaluation of EROI of complex systems from the bottom (each technology) up (the system) requires the identification of subsystems in series or parallel and evaluate their respective EROI, and then to proceed to the evaluation of the system's overall EROI. Example of in-series technologies is the production of biomethane from biogas by up-grading process the gasoline production by distillation of oil, etc., in those cases the total useful EC decreases at each step.

Fig. 4 shows the calculation of the overall EROI for a system constituted by two technology steps in series and in parallel by applying Eq.s (7). Fig. 4 a) shows the maximum total  $EC_{usef,full}$  obtainable in the case of two step in series; the overall *useful energy* depends on the efficiency conversion of the net energy produced in the first step into the useful energy by the second step, because the *stocks/flows* entering at  $i$ -th step is the *useful* energy of  $(i-1)$ -th step. Fig. 4 a) shows the calculation of the useful energy, the generalization of the expression reported in it is:

$$EC_{usef,tot} = EC_{net,1} \prod_{i=1}^n \left( 1 - \frac{1}{EROI_i} \right) \quad (8)$$

$$\prod_{i=1}^n \left( 1 - \frac{1}{EROI_i} \right) = \left( 1 - \frac{1}{EROI_{Syst}} \right)$$

In the case of systems with technologies in parallel, for example, the electrical system using fossil and renewable resources, in which the useful EC of each is added as shown in Fig. 4b), considering the equations reported in it, the following generalized equation is obtained, which allows to evaluate the total EROI of the global system:

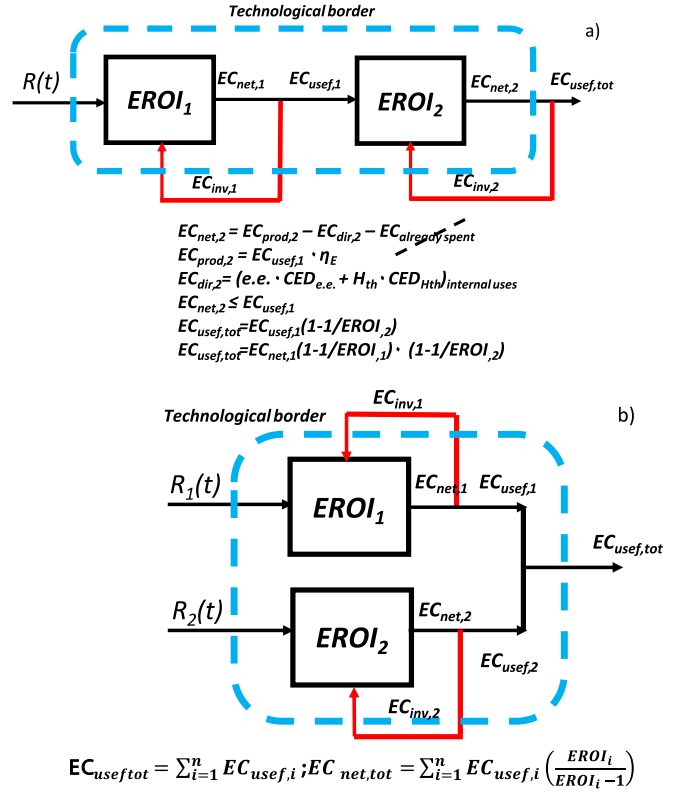

Fig. 4. Combinations of two technologies (ECPT) to produce EC. Reference schemes for the EROI evaluation of ECs technological systems consisting of two steps: a) series technologies, e.g., biogas production followed by an up-grading technology (note that for technology 2, the  $EC_{already\ spent} = 0$ , in this case  $EC_{usef,tot}$  is the max obtainable, see text); b) parallel technologies, e.g., electrical system in which electricity is produced from PER in parallel. The blue dotted line represents the boundary of technology. (For interpretation of the references to colour in this figure legend, the reader is referred to the web version of this article.)

$$EC_{usef,tot} = \sum_{i=1}^n EC_{net,i} \left( 1 - \frac{1}{EROI_i} \right) = EC_{net,tot} \left( 1 - \frac{1}{EROI_{Syst}} \right) \quad (9)$$

where  $i$  is the  $i$ -th component of the systems. Knowing each  $EC_{usef,i}$  and  $EROI_i$  it is possible to evaluate  $EROI_{Syst}$ . The Eq. (9) is of interest in modelling the evolution of the overall EROI of an electrical system that receives a share of technologies that use renewable sources either in addition to those that use fossil resources or to replace them according to a given replacement trajectory.

Fig. 5 shows the trend of the total  $EROI_{Syst}$  of an electrical system consisting of two technologies in parallel as function of a substitution parameter ( $\alpha$ ). It can be seen that the value of the  $EROI_{Syst}$  is an intermediate between the two technologies. For more complex systems, consisting of multiple of technologies in series and parallel, the modelling can be done using a combination of Eq.s (8) and (9) and to forecast the value of the  $EROI_{Syst}$  (hence its sustainability).

### 3.3. Case study: Production of H<sub>2</sub> via polymer electrolyte membrane

The SFFS approach for EROI calculations has been previously applied to EC, such as biogas from different feedstock [18] and distributed hydrogen production [60]. In [18] a detailed analysis of different substrates and their technological requirements for Anaerobic Digestion (AD) is presented and compared using energy metrics (ESI, EROI and EPT), while in [60] H<sub>2</sub> production with different ECPT such as SMR, water electrolysis (using electricity produced from PV panels) and AD are compared using data obtained from pilot-plants experimental

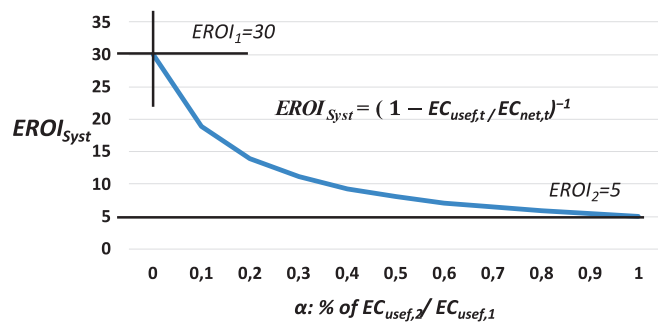

**Fig. 5. EROI evaluation of a system of technologies in parallel.** Example of EROI calculation of a system consisting of two parallel technologies having two different EROI values, providing the same energy carrier; technology 1) has an EROI of 30, while technology 2) has an EROI of 5 (e.g., an electricity system that produces electricity from non-renewable sources and renewable PER).  $\alpha$  is the replacement percentage evaluated on the  $EC_{useful}$ , keeping constant the energy demand. As it can be seen, the value of  $EROI_{System}$  is an intermediate between the two for single technologies.

campaigns. Here, a case study of EROI estimation through the SFFS approach for a  $H_2$ -producing technology is reported, using literature data. As shown in Fig. 6, the technology under analysis consists in the production of the so-called *green hydrogen* using an electrolyser, where the flow of solar radiation is transformed into  $H_2$ . This EC technology is currently under scrutiny by government agencies, and to public attention over all the world. Differently than [60] where, to keep the electrolyser running continuously, in the absence of solar radiation, the grid electricity was used, conversely in the present analysis, it is hypothesized that daily surplus electricity is stored in a pumping hydro storage system (PHS) to allow the continuous production. In addition, a survey of the main required components of the system was conducted and the results of the most advanced researches have been used, even if they are not yet deployed on an industrial scale.

The simplified block diagram depicted in Fig. 6 shows the essential components of the  $H_2$ -producing EC system under examination, here only a brief analysis is reported (for more details refer to the cited bibliography). The system consists of a dedicated photovoltaic field (PV), on the ground (not roof-mounted). Then an inverter (I) is required to transform the generated direct current electricity into alternating current (i.e., to render it compatible with direct use in houses and to be fed to the grid). The transmission (T) grid and the PHS are referred to the

Italian system. The chosen electrolyser for the example is of Polymer Electrolyte Membrane (PEM) type; the PEM type is simpler than the alkaline type albeit at a lower level of industrial development [47]. PEM electrolysers do not require large volumes of chemicals (other than  $H_2O$ ), in particular it does not need NaOH inputs, which is energy intensive ( $CED_{NaOH} = 16 \text{ MJ/kg}$  [55]). Balance Of Plant (BOP) refers to auxiliary and indispensable devices for the operation of PEM, such as circulation pumps, heat exchangers, temperature and pressure control and monitoring, gas-separator, de-oxygenation component, gas dryers, etc. The PEM and BOP reported in [61] were used as reference, since a detailed inventory of materials, which allows to evaluate the energy expenses for its construction (see Table 6 and 7). The PEM allows for operation under anode and cathode differential pressure, (typically 30 bar to 70 bars) hence thicker membranes are required to improve the mechanical stability and decrease gas permeation. PEM setups can also require additional catalysts to re-convert  $H_2$ , which due to higher pressures might permeate back to water. In order to limit this phenomenon and to avoid the use of compressors (to avoid efficiency reductions and additional energy expenses), optimal BOP components are considered. The reference BOP optimization is taken from [62], in which the pressure in the electrolyser stack increases following the evolution of  $H_2$  (without compressor), hence decreasing the energy expenses (about 4% of the LHV at 30 bar) [47].

**Table 6**  
Mass components and energy invested for 1 MW PEM electrolyser stack [61].

Component	Quantity (kg)	GER (MJ/kg) <sup>a)</sup>	Total energy (MJ)	Share (%)
Titanium	528.000	527.282	278404.767	56.78
Aluminum	27.000	54.613	1474.552	0.30
Stainless steel	100.000	54.445	5444.496	1.11
Copper	4.500	72.866	327.899	0.07
Nafion®	16.000	122.806	1964.892	0.40
Activated carbon	9.000	39.005	351.042	0.07
Palladium (Iridium)*	0.750	166547.073	124910.305	25.48
Platinum	0.075	1032435.544	77432.666	15.79
<b>Total (MJ)</b>			<b>4.90E + 05</b>	

\* Palladium dataset was used as substitute (i.e., iridium is not present in databases).

a) From SimaPro 9.1.1.1, Method Cumulative Energy Demand (LHV) 1.0, using the USLCI, ELCD, Ecoinvent 3 and Industry Data 2.0 databases.

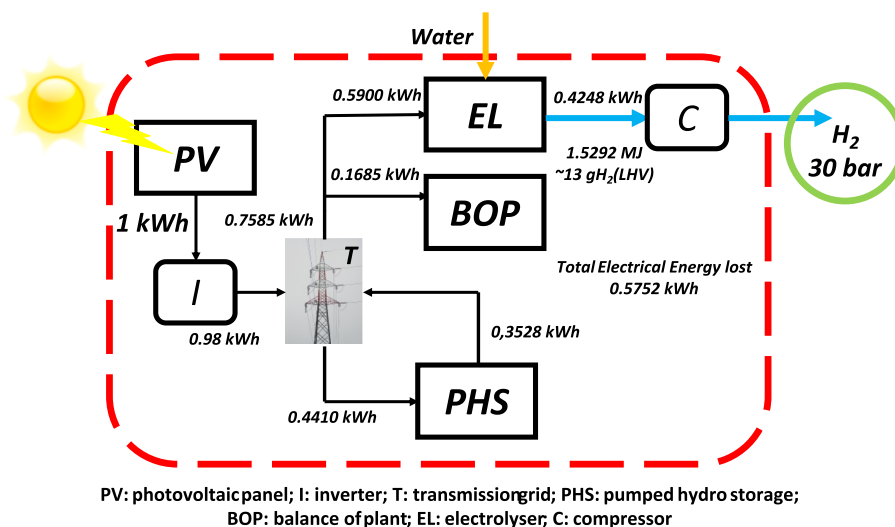

**Fig. 6. Technology reference scheme for solar  $H_2$  production at 30 bar by PEM electrolyser;** the dotted red line represents the technology boundary. (For interpretation of the references to colour in this figure legend, the reader is referred to the web version of this article.)

**Table 7**

Mass component and energy invested for the BOP for 1 MW PEM electrolyser [61].

Components	Quantity (kg)	GER (MJ/kg) <sup>a)</sup>	Total energy (MJ)	Share (%)
Low alloyed steel	4,800	24.083	115,600.00	1.29
High alloyed steel	1,900	54.445	103,445.40	14.57
Aluminum	100	54.613	5,461.30	0.77
Copper	100	72.866	7,286.63	1.03
Plastic	300	5.549	1,664.83	0.23
Electronic material	1,100	417.328	459,060.80	64.68
Process material	200	62.088	12,417.51	1.75
Concrete	5,600	0.866	4,849.04	0.68
<b>Total (MJ)</b>			<b>7.10E + 05</b>	

<sup>a)</sup> From SimaPro 9.1.1.1, Method Cumulative Energy Demand (LHV) 1.0, using the USLCL, ELCD, Ecoinvent 3 and Industry Data 2.0 databases.

Fig. 6 shows the electricity losses considering 1 kWh produced by PV taking into account the efficiencies of different component. For the current conversion, an efficiency for the I of 98% was considered, as reported on different datasheet by different producers. The electricity losses over T were considered of 10% as evaluated in [51], while the amount of energy stored in the PHS is only 50% of the produced one. An oversized PV field producing twice as much power as needed by the electrolyser is considered. Hence, during sunshine hours the overproduction is stored to be used during night hours (as shown in Fig. 7).

Indeed, continuous operation of PEM systems under constant electrical loads maximize their efficiency [47]. For storage, the PHS system was chosen with a round-trip energy efficiency of 80% [63] which is higher compared to other storage technologies with an useful life of around 150 years. The footprint of the accumulation basin is low, since the energy invested in the materials per unit of stored kWh is allocated over the operative life and the total stored energy [64]. Lastly, it was decided to consider PHS as storage because in Italy about 8 GW are available with 3.3 TWh average annual storage quantity [65]; PHS capacity remains underused but it is able to absorb, at least for now, large quantities of variable electricity production. Dedicated storage technologies, included within the boundaries of the H<sub>2</sub>-producing technology, were not considered since they would have increased the energy invested (i.e., the denominator of the EROI). The electricity split between the PEM stack electrolyser (EL) and the BOP auxiliaries, a stack efficiency of 72% and a system efficiency of 56%, respectively were used [62]. Hence 77.8% of the electricity arriving at the PEM is used by the stack for H<sub>2</sub> production. Thus the amount of produced energy is 1.5292 MJ/kWh under form of H<sub>2</sub> per unit of electricity produced by the PV field, which corresponds to about 13 g of H<sub>2</sub> on LHV, at 30 bar. To evaluate the numerator of the EROI, it is considered that:  $EC_{avoided}$  energy and  $EC_{dir}$  are equal to zero because as the first is obvious, being the stocks/flows solar energy and water, while for the second, no stocks/flows

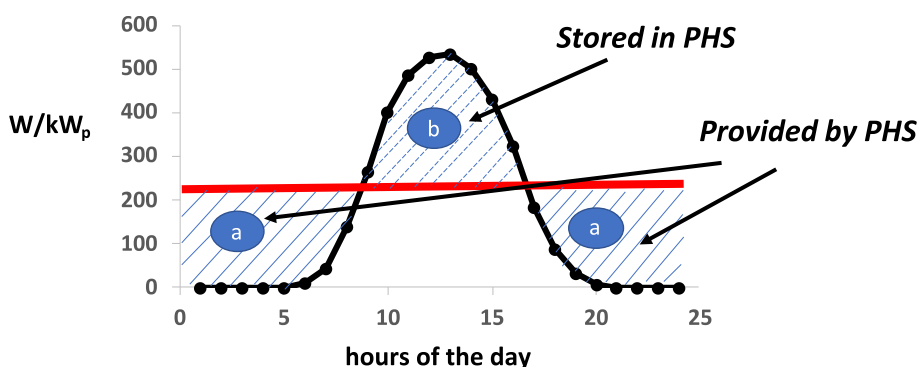

**Fig. 7.** Mean daily instantaneous power produced in Italy from PV fields (yearly averaged); incoming irradiance 1550 kWh/m<sup>2</sup>year. The power -W- is reported on Wp (Wp standard condition: Irradiance of 1000 W/m<sup>2</sup>, 25 °C, 1.5 Optical Air Mass). The electrolyser works continuously (horizontal red line) while the electric power is supplied directly by PV field from 9 a.m. until approximately 17p.m. For the remaining hours, it is partially or totally supplied by the PHS accumulation system (dotted area a) where the overproduction during the day is stored (dotted area b). (For interpretation of the references to colour in this figure legend, the reader is referred to the web version of this article.)

from the anthropological sphere are used to run the technology (i.e. all the energy needs are covered internally Fig. 6). As for the term  $EC_{already\ spent}$  it is the energy expended in the anthropological domain to bring stocks/flows within the boundaries of technology. Being the stocks/flows (the ingredients) the solar energy and the water, obviously only the term referring to the latter should be considered. The amount of water is equal to 9 kg for 1 kg of H<sub>2</sub> (stoichiometrically) which rises up to about 20 for all other needs [47]; therefore  $(9 \times 13 \times 10^{-3})$  kg<sub>H<sub>2</sub>O</sub>/kWh is the stocks spend in the stack, which required an energy expenditure of  $(9 \times 13 \times 10^{-3} \times 12 \times 10^{-3}) = 1.5 \times 10^{-3}$  MJ/kWh, ( $12 \times 10^{-3}$  MJ/kg is the CED of tap water [55]), and 11 kg is the quantity invested to run the plant. In fact, it has been labelled as a chemical to run the BOP. Ultimately, the numerator of EROI is:

$$EC_{net} = EC_{prod} - EC_{already\ spent} = 1.5292 - 1.5 \times 10^{-3} = 1.5277 \text{ MJ/kWh.}$$

The calculation of the denominator, i.e.,  $EC_{inv}$ , Tables 6 and 7 show the embedded energy of the EL and BOP materials, respectively, while Table 8 shows the results of the various items for each single component of the system; details for the execution of the calculation are given in the Appendix; the total  $EC_{inv}$  is 1.5790 MJ/kWh, finally:

$$EROI = 1.5277 / 1.5790 = 0.97.$$

This means that the technology it is not energetically sustainable. It requires a 3% of energy from the anthropological sphere for its energy sustainability, therefore it rather subtracts energy from other energy services. In addition, the value of EROI decreases in consideration of the fact that the produced H<sub>2</sub> at 30 bar requires further energy expenses for compression and transportation to the final point of use.

It is very difficult to compare this result with literature data as the methodologies used for EROI evaluation are completely different. For example, in [66] the EROI of H<sub>2</sub> production via solar-based high-temperature steam electrolysis is calculated. However, the definition of EROI is different and the net energy is not calculated considering the direct energy spent, but rather accounted for as invested energy. Or considering the definition of EROI as the ratio between LHV and CED, also in this case, being the CED the sum of the energy subtracted from the anthropological sphere plus that from the biophysical sphere (i.e., LHV) how it can be >1? Not to mention the difficulty of applying this definition to electricity. Even the comparison with other technologies is difficult because the applied methods are very different as in [67] where EROI is defined as the ratio between output and input LHV or in [68] where EROI is generically defined as output energy on input energy without further explanation.

EROI values obtained for similar ECs using the SFFS approach [60] also differ in a wide range. For example, in [60] low EROIs were obtained (below 0.1 compared to the current 0.97). The differences can be explained by considering several factors. In the present analysis more advanced research data (e.g., the PEM electrolyser) are used, while in [60] data derived from an experimental campaign. Additionally, the reference [60] had a different energy consumption pattern (without

**Table 8**Share of invested energy (*funds/flows*) for each component of the H<sub>2</sub> EC production, evaluated as MJ/kWh PV produced.

$E_{inv,i}$	PV	I	T	PHS	EL	BOP	Tot
$EC_{chem}$	0.000	0.000	0.000	0.000	0.000	0.002	0.002
$EC_{mat}$	0.381	$7.9 \times 10^{-4}$	$2.9 \times 10^{-3}$	0.000	0.006	0.073	0.461
$EC_{constr}$	0.229	$1.6 \times 10^{-5}$	$8.1 \times 10^{-4}$	0.000	$0.6 \times 10^{-4}$	0.022	0.251
$EC_{decom}$	0.152	$1.6 \times 10^{-5}$	$8.1 \times 10^{-4}$	0.000	$0.6 \times 10^{-4}$	0.022	0.174
$EC_{labour}$	$4.9 \times 10^{-3}$	0.000	0.000	0.000	0.000	0.000	0.005
$EC_{maint}$	0.153	0.000	$5.8 \times 10^{-3}$	0.000	0.003	0.055	0.216
$EC_{mort}$	0.381	$7.9 \times 10^{-4}$	$2.9 \times 10^{-3}$	0.000	0.006	0.073	0.461
$EC_{ind\ dir}$	0.000	0.000	0.000	0.000	0.000	0.000	0.000
<b>Tot</b>	<b>1.301</b>	<b>0.002</b>	<b><math>13.2 \times 10^{-3}</math></b>	<b>0.000</b>	<b>0.016</b>	<b>0.247</b>	<b>1.579</b>
<b>Share %</b>	<b>82.69</b>	<b>0.10</b>	<b>0.48</b>	<b>0.00</b>	<b>1.03</b>	<b>15.70</b>	

PHS) which required electricity from the grid in the absence of solar energy as  $EC_{dir\ spent}$ . Obviously these two aspects affect the EROI metric. In addition, the PEM electrolyser type does not require alkaline solutions (hence, reducing the energy of *funds/flows*). Moreover, the experimental PV plant consisted of photovoltaic cells built in the early 2000s, with a very high energy footprint of around 6,000 MJ/m<sup>2</sup> [69], while in the present analysis a value of the CED of 1,800 MJ/m<sup>2</sup> [70] was considered (i.e., incorporating all the energy efficiencies in the multi-crystalline Si PV panel manufacturing, including the decreased thicknesses). For the BOP, the auxiliary materials (including those for assembly) remained substantially unchanged [70]. Lastly, the PV efficiency has increased from 8, 9% [60] to above 20% of currently commercialized PV modules. Additionally, Table 8 shows that the research areas which can render this EC process more energy sustainable are: PV accounts for 82% of the invested energy, followed by BOP which accounts for 16%, while the PEM stack unexpectedly weighs only 1%.

The EROI evaluation of electricity production by PV, which is extensively present in the literature [74], with the present method is very simple. Considering I within the technology, i.e., EROI of the PV electricity fed into the grid, the numerator  $EC_{net} = 0.98 \times 3.6 = 3.523$  MJ/kWh (Fig. 6), while the sum of the first two columns of Table 8 goes to the denominator  $EC_{inv} = 1.303$  MJ/kWh, therefore EROI = 2.7, meaning that 37 % of electricity goes to support the technology and 63% is available to cover energy services using electricity as the EC. In the hypothesis of covering services that require other forms of EC, the energy costs of subsequent technologies must be considered, as in the present case, electricity converted into H<sub>2</sub> causes a drop in EROI towards the unsustainable range.

#### 4. Conclusions

The use of the SFFS production model of N.G. Roegen applied to ECs producing technologies represents a solid basis for being able to uniquely identify the terms necessary for the evaluation of the EROI and to perform energy sustainability analyses. In addition, the EROI metric can be applied to single level technologies and complex systems, although in series and/or in parallel technologies require a dedicated approach. Indeed, the method is also valid for fossil and renewable PER or for multiple input systems. The procedure applied to the production of “green hydrogen” via electrolysis using a PEM electrolyser powered by photovoltaic electricity lead to a value of EROI = 0.97, thus this EC is not energetically sustainable requiring at least 3% of energy from the anthropological sphere (i.e., subtracted from other energy services). Lastly, the SFFS approach should be used to guide the development and selection of EC technologies at infancy stages (TRL < 3) based on the most promising ones in term of energy sustainability, towards which human efforts and financial resources should be directed/invested.

#### Funding

This research did not receive any specific grant from funding agencies in the public, commercial, or not-for-profit sectors.

#### CRedit authorship contribution statement

**Bernardo Ruggeri:** Conceptualization, Methodology, Writing – original draft, Writing – review & editing, Visualization. **Carlos E. Gómez-Camacho:** Software, Data curation, Validation, Writing – review & editing.

#### Declaration of Competing Interest

The authors declare that they have no known competing financial interests or personal relationships that could have appeared to influence the work reported in this paper.

#### Data availability

No data was used for the research described in the article.

#### Appendix A

Calculation of the denominator of the EROI of the individual components of the H<sub>2</sub> production technology (ref. Fig. 6); base 1 kWh obtained by photovoltaic panels.

PV, photovoltaic panel.

- Total solar irradiation per unit of surface per year, mean value for Italy territory,  $I_r = 1,550$  (kWh/m<sup>2</sup>year) [71]
- PV module efficiency at factory:  $\eta = 22$  % under Standard Test Conditions (STC: incident sun light with a spectral distribution defined by AM1.5G, integrated intensity of 1000 W/m<sup>2</sup>, and module temperature of 25°; (value taken from commercial catalogues)
- PR performance ratio, (PR = actual electricity/nominal electricity) is the ratio of the actual to theoretical energy output of a PV module. It reveals how well a system behaves under actual conditions; it includes all inefficiencies in energy output, as the effects of variations in insolation, reduced efficiency associated with elevated module temperature, shading, soiling or snow cover, and inverter inefficiency, it is generally measured in 1 year time interval; value of 70 % was used in a measured range of (20–80) %<sup>(\*)</sup>;
- Areal nominal electricity of PV:  $I_r \times \eta = 1,550 \times 0.22 = 341$  (kWh/m<sup>2</sup>year) [72]
- Actual electricity generated:  $341 \times 0.7 = 239$  (kWh/m<sup>2</sup>year); duration 30 year, electricity generated 7,170 (kWh/m<sup>2</sup>)
- $EC_{mat}$ , considering the energy embedded in multi crystalline Si PV panel CED = 1,800 (MJ/m<sup>2</sup>) [70] plus that of Balance Of System (BOS) (wiring, switches, support racks, excluding inverter) for ground installation, as mean value 932 (MJ/m<sup>2</sup>) [72],  $EC_{mat} = 2,732/7,170 = 0.381$  (MJ/kWh)
- $EC_{constr}$ , 60% of  $EC_{mat}$  for supporting infrastructure, anticorrosion treatment, fence etc. including concrete<sup>(\*)</sup>,  $EC_{constr} = (2,732 \times 0.6)/7,170 = 0.229$  (MJ/kWh)

- $EC_{decom}$ , it is slightly lower than the energy expenditure for construction, as concrete structures are generally not removed, 40%; 0.152 (MJ/kWh)
- $EC_{labour}$ , for assembly and disassembly: 3 workers, 7 working days for 20 m<sup>2</sup>(<sup>2</sup>); considering 4,000 kcal/meal, (4,000 × 2 × 3 × 7 × 4.18\*10<sup>-3</sup>)/20 = 35 (MJ/m<sup>2</sup>), hence  $EC_{labour} = 4.9*10^{-3}$  (MJ/kWh)
- $EC_{maint}$ , two contribution needs to be considered: PV modules and the BOS; as regards the first two elements be accounted: i) the replacement of the surface module due to the drop of its efficiency over time, of about 0.6%/year [73], which over 30 years leads a loss of about 4% and ii) loss due to breakages, damages including thefts, for a ground systems, quantifiable around 1%/year (<sup>6</sup>), which over 30 years involves a loss of 26% of surface. It is supposed to restore these losses by adding more surface area, which in energy term is: [(0.26 + 0.04) × 1,800]/7,170 = 0.075 (MJ/kWh); BOS maintenance, quantifiable in 2%/year (active and passive corrosion control, restoration of parts, etc.): (932 × 0.02 × 30)/7,170 = 0.078 (MJ/kWh); total  $EC_{maint} = 0.153$  (MJ/kWh)
- $EC_{amort}$ , coincides with  $EC_{mat}$  (see text): 0.381 (MJ/kWh)
- $EC_{ind\ dir}$ , this term is equal to zero, since (I) inverter is accounted as a constituent of the system

I, inverter.

- $EC_{mat}$ , the inverter was chosen by selecting from the manufacturers' catalogs the one with the lowest mass (energy) intensity (see the following Table A1):

250 kW of power, duration 10 years; considering as constituted by 50% of steel and 50% of copper, the  $CED = 113x (CED_{Cu}x0.50 + CED_{steel}x0.5) = (72.866 × 0.5 + 54.445 × 0.5) × 113 = 7,193$  (MJ); considering an additional 20% of material for assembly:  $CED_{inverter} = 8,632$  (MJ). To evaluate the energy intensity per functional unit, the energy "handled" by the inverter is: 250 × 12 × 365 × 10 = 11\*10<sup>6</sup> (kWh), hence  $EC_{mat} = 8,632/11*10^6 = 7.9*10^{-4}$  (MJ/kWh).

- $EC_{constr}$ , considered as 2% of  $EC_{mat}$ :  $7.9*10^{-4}x0,02 = 1.6*10^{-5}$  (MJ/kWh)
- $EC_{decom}$ , as  $EC_{constr} = 1.6*10^{-5}$  (MJ/kWh)
- $EC_{labour}$ , negligible
- $EC_{maint}$ , negligible
- $EC_{amort}$ ,  $7.9*10^{-4}$  (MJ/kWh)
- $EC_{ind\ dir}$ , equal zero

T, grid of transmission.

- $EC_{mat}$ , Table A2 shows the characteristics of the Italian electricity grid [51] and its embedded energy:

a) Mean value from [55]

the total energy invested in the grid is 8.60E + 10 (MJ); considering a mean duration of 100 year and if the electricity transported per year equals 320\*10<sup>9</sup> (KWh) (\*\*\*) the  $EC_{mat} = 0.0029$  (MJ/kWh) transported.

- $EC_{constr}$ ,  $EC_{decom}$ , the same value, considered equal to 30% of  $EC_{mat}$
- $EC_{labour}$ , negligible
- $EC_{maint}$ , mean value 2% yearly of  $EC_{mat}$ ,  $EC_{maint} = 5.8*10^{-3}$  (MJ/kWh)
- $EC_{amort}$ , 0.0029 (MJ/kWh)
- $EC_{ind\ dir}$ , equale zero

PHS, pumping hydro storage.

- The storage systems briefly consist of two aggregates, the basin plus concrete structures and steel mechanical parts, the former have an average duration of 150 years while the latter 30 years. The primary question is to evaluate whether the PHS contribution is to be

**Table A1**  
Inverter characteristics, from brochures.

Power (kW)	3	30	250	1,000
Mass (kg)	22	50	113	4,000
Intensity (kg/kW)	7.3	1.6	0.45	4

**Table A2**  
Italian grid characteristics.

Partition (voltage)	Extension (km)	CED (MJ/km) <sup>a)</sup>	Energy (MJ)
Low	48,934	726,604.63	3.56*10 <sup>10</sup>
Medium	10,876	789,201.24	8.58*10 <sup>10</sup>
High	11,202	3,740,213	4.19*10 <sup>10</sup>

considered or not. The power of PEM electrolyser is 1 MW [61] with a duration of 6.5 years [47] hence the necessary electricity is 60\*10<sup>6</sup> kWh, which is supplied by PV; considering the italian PHS storage capacity of 7.3 GW (\*\*\*) , the "storable" electricity in 6.5 years would be 208\*10<sup>9</sup> kWh, therefore the PHS utilization coefficient is equal to 0.000288 i.e. the load of the energy incorporated in the materials of the PHS on PV electricity is of 0.0288%, hence its contribution was considered negligible using the LCA cut-off criterion.

EL, PEM electrolyser stack.

- $EC_{chem}$ , equal zero (see text)
- $EC_{mat}$ , from Table 6, the invested energy is 4.90\*10<sup>5</sup> (MJ), the electricity used by PEM stack during 6.5 year, in continuous operation for 320 day/year is 49.9\*10<sup>6</sup> (kWh), the energy intensity is 9.8\*10<sup>-3</sup> (MJ/kWh<sub>stack</sub>), which referred to kWh produces by PV (see Fig. 6) is: 9.8\*10<sup>-3</sup> × 0.6243 = 0.006 (MJ/kWh)
- $EC_{constr}$ ,  $EC_{decom}$ , the same value considered equal to 10% of  $EC_{mat}$
- $EC_{labour}$ , negligible
- $EC_{maint}$ , mean value 5% yearly of  $EC_{mat}$ , for replacement of electrode leakage and erosion [47]  $EC_{maint} = 3.0*10^{-3}$  (MJ/kWh)

BOP, balance of plant.

- $EC_{chem}$ , 11 kg of water, which corresponds 0.143 (kg<sub>H2O</sub>/kWh) (see Fig. 6), hence  $EC_{chem} = 0.143 × 12*10^{-3}$  (CED<sub>H2O</sub>) [55] = 0.002 (MJ/kWh)
- $EC_{mat}$ , from Table 7, the invested energy is 7.1\*10<sup>5</sup> (MJ), the necessary electricity is 1.73\*10<sup>6</sup> (kWh)<sub>BOP</sub>, referred to kWh produces by PV (see Fig. 6) is: 0.411 × 0.1783 = 0.073 (MJ/kWh)
- $EC_{constr}$ ,  $EC_{decom}$ , the same value equal to 30% of  $EC_{mat}$
- $EC_{labour}$ , negligible
- $EC_{maint}$ , mean value 5% yearly of  $EC_{mat}$ , for consumable materials, pump replacement and corrosion control [47]  $EC_{maint} = 0.055$  (MJ/kWh)

(\*)This information, like others regarding energy consumption for PV installation and maintenance, is private communication from installers and maintenance technicians of systems in Italy.

(\*\*) <https://www.terna.it/it/media/comunicati-stampa/dettaglio/consumi-elettrici-2022>.

(\*\*\*) <https://www.rinnovabili.it/energia/sistemi-di-accumulo/sistemi-di-accumulo-energy-storage-2021/>.

**References**

[1] Whyte P, Lamberton G. Conceptualising Sustainability Using a Cognitive Mapping Method. Sustainability 2020;12(1977). <https://doi.org/10.3390/su12051977>.  
 [2] Ruggerio CA. Sustainability and sustainable development: A review of principles and definitions. Sci Total Environ 2021;786:147481. <https://doi.org/10.1016/j.scitotenv.2021.147481>.

- [3] Gallopín GC. Sostenibilidad y desarrollo sostenible: un enfoque sistémico. CEPAL-NACIONES UNIDAS, Santiago de Chile: Serie Medio Ambiente y Desarrollo; 2003.
- [4] Glavič P, Lukman R. Review of sustainability terms and their definitions. *J Clean Prod* 2007;15:1875–85. <https://doi.org/10.1016/j.jclepro.2006.12.006>.
- [5] IEA. World Energy Outlook 2020. (2020). (available at <https://www.iea.org/report-s/world-energy-outlook-2020>).
- [6] BP, Statistical Review of World Energy. 69th Edition; 2020. (available at [www.bp.com/content/dam/bp/business-sites/en/global/corporate/pdfs/energy-economics/statistical-review/bp-stats-review-2020-full-report.pdf](http://www.bp.com/content/dam/bp/business-sites/en/global/corporate/pdfs/energy-economics/statistical-review/bp-stats-review-2020-full-report.pdf)).
- [7] IEA. Global Energy Review: CO2 Emissions (2021) (available at <https://www.iea.org/reports/global-energy-review-2020/global-energy-and-co2-emissions-in-2020> visited 4-5-2021).
- [8] IRENA, International Renewable Energy Agency, Global Energy Transformation, A roadmap to 2050, (2018). (available at <https://www.irena.org/publications/2018/Apr/Global-Energy-Transition-A-Roadmap-to-2050>).
- [9] Hall CAS. Will EROI be the Primary Determinant of Our Economic Future? The View of the Natural Scientist versus the Economist. *Joule* December 20, (2017);1: 635–8, <http://doi.org/10.1016/j.joule.2017.09.010>.
- [10] Moran MJ, Shapiro HN, Boettner DD, Bailey MB. Fundamentals of engineering thermodynamics, John Wiley & Sons, Inc. 2014.
- [11] Haber H, et al. Stocks, flows, services and practices: Nexus approaches to sustainable social metabolism. *Ecol Econ* 2021;182:106949. <https://doi.org/10.1016/j.ecolecon.2021.106949>.
- [12] Odum TH. *Energy, Ecology and Economics*. *Ambio* 1973;4(6):220–7.
- [13] Udo de Haes HA, Heijungs R. Life-cycle assessment for energy analysis and management. *Appl Energy* 2007;84(7-8):817–27. <http://doi.org/10.1016/j.apenergy.2007.01.012>.
- [14] Sgouridis S, Carbajales-Dale M, Csala D, Chiesa M, Bardi U. Comparative net energy analysis of renewable electricity and carbon capture and storage. *Nat Energy* 2019;4(456):456–465. <http://doi.org/10.1038/s41560-019-0365-7>.
- [15] Arvesen A, Hertwich EG. More caution is needed when using life cycle assessment to determine energy return on investment (EROI). *Energy Policy* 2015;76(1–6). <https://doi.org/10.1016/j.enpol.2014.11.025>.
- [16] Hong S, Kim E, Jeong S. Evaluating the sustainability of the hydrogen economy using multi-criteria decision-making analysis in Korea. *Renew Energy* 2023;204(485–492). <https://doi.org/10.1016/j.renene.2023.01.037>.
- [17] Mirowski P. Energy and Energetics in Economic Theory: A Review Essay. *Jei J Econ* September 1988;XXII(3). <https://doi.org/10.1080/00213624.1988.11504810>.
- [18] Gomez-Camacho CE, Pirone R, Ruggeri B. Is the Anaerobic Digestion (AD) sustainable from the energy point of view? *Energy Convers Manage* 2021;231: 113857. <http://doi.org/10.1016/j.enconman.2021.113857>.
- [19] Richard GN, Raimi D. Global Energy Outlook Comparison Methods: 2020 Update, Resources for the Future, Report 20-06 (2020) (available at [https://media.rff.org/documents/Global\\_Energy\\_Outlook\\_Comparison\\_Methods\\_2020.pdf](https://media.rff.org/documents/Global_Energy_Outlook_Comparison_Methods_2020.pdf)).
- [20] Murphy DJ, Hall CAS, Dale M, Cleveland C. Order from Chaos: A Preliminary Protocol for Determining the EROI of Fuels. *Sustainability* 2011;3:1888–1907. <http://doi.org/10.3390/su3101888>.
- [21] King CW. Matrix method for comparing system and individual energy return ratios when considering an energy transition. *Energy* 2014;72(254–265). <https://doi.org/10.1016/j.energy.2014.05.032>.
- [22] Brandt AR, Dale M. A General Mathematical Framework for Calculating Systems-Scale Efficiency of Energy Extraction and Conversion: Energy Return on Investment (EROI) and Other Energy Return Ratio. *Energies* 2011;4:1211–45. <https://doi.org/10.3390/en4081211>.
- [23] Mulder K., Hagens N.J. Energy return on investment: Toward a consistent framework. *AMBIO: J Hum Environ* 2008;37:74–79. [https://doi.org/10.1579/0044-7447\(2008\)37\[74:EROITAJ\]2.0.CO;2](https://doi.org/10.1579/0044-7447(2008)37[74:EROITAJ]2.0.CO;2).
- [24] Carbajales-Dale M. When is EROI Not EROI?, *BioPhysical Economics and Resource Quality* 2019;4:16. <https://doi.org/10.1007/s41247-019-0065-8>.
- [25] Franzese PP, Rydberg T, Russo GF, Ulgiati S. Sustainable biomass production: a comparison between Gross Energy Requirement and Emery Synthesis methods. *Ecol Indic* 2009;9(959–70). <https://doi.org/10.1016/j.ecolind.2008.11.004>.
- [26] Raugi M. Comments on “Energy intensities, EROIs (energy returned on invested), and energy payback times of electricity generating power plants” - Making clear of quite some confusion. *Energy* 2013;59:781–2. <http://doi.org/10.1016/j.energy.2013.07.032>.
- [27] Brockway PE, Owen A, Brand-Correa LI, Hardt L. Estimation of global final-stage energy-return-on-investment for fossil fuels with comparison to renewable energy sources. *Nat Energy* JULY 2019;4(612):612–21. <http://doi.org/10.1038/s41560-019-0425-z>.
- [28] Weißbach D, Ruprecht AG, Huke K, Czernski S, Gottlieb A, Hussein. Energy intensities, EROIs (energy returned on invested), and energy payback times of electricity generating power plants’ - Making clear of quite some confusion. *Energy* 52, 210-221 (2013) 10.1016/j.energy.2013.01.029.
- [29] Weißbach D, Ruprecht G, Huke A, Czernski K, Gottlieb S, Hussein A. Reply on “Comments on ‘Energy intensities, EROIs (energy returned on invested), and energy payback times of electricity generating power plants’ - Making clear of quite some confusion. *Energy* 2014;68:1004–1006. <http://doi.org/10.1016/j.energy.2013.01.029>.
- [30] Raugi M, Carbajales-Dale M, Barnhart CJ, Vasilis F. Rebuttal: “Comments on ‘Energy intensities, EROIs (energy returned on invested), and energy payback times of electricity generating power plants’ e Making clear of quite some confusion. *Energy* 2015;82:1088–91. <http://doi.org/10.1016/j.energy.2014.12.060>.
- [31] Raugi M, Frischknecht M, Olson C, Sinha P, Heath G. Methodological guidelines on Net Energy Analysis of Photovoltaic Electricity, IEA-VPVS Task 12, Report T12-07:2016, ISBN 978-3-906042-39-8 (2016) <https://iea-vpvs.org/wp-content/uploads/2020/01/Task12>.
- [32] Jackson A, Jackson T. Modelling energy transition risk: The impact of declining energy return on investment (EROI). *Ecol Econ*. 2021;185:107023. <http://doi.org/10.1016/j.ecolecon.2021.107023>.
- [33] Viviana FD, Nieldua M, Beforte N, Debrea R, Giampietro M. The Hijacking of the Bioeconomy. *Ecol Econ* 2019;159(189–197). <https://doi.org/10.1016/j.ecolecon.2019.01.027>.
- [34] “Bioeconomy - OECD.” <https://www.oecd.org/sti/futures/bioeconomy.htm> (accessed Oct. 14, 2022).
- [35] Totten MP. Flourishing Sustainably in the Anthropocene? Known Possibilities and Unknown Probabilities. *Ref Module Earth Syst Environ Sci* 2018. <https://doi.org/10.1016/B978-0-12-409548-9.10910-8>.
- [36] Georgescu-Roegen N, 219 in. *The Entropy Law and the Economic Process*. Cambridge: Harvard Univ. Press; 1971.
- [37] Giorgos K, Kerschner C, Martinez-Alier J. The economics of degrowth. *Ecol Econ* 2012;84:172–80. <https://doi.org/10.1016/j.ecolecon.2012.08.017>.
- [38] Solow RM. Technical Change and the Aggregate Production Function. *Rev Econ Stat* 1957;39(3):312–20. <https://www.jstor.org/stable/1926047>.
- [39] Stiglitz J. Growth with Exhaustible Natural Resources: Efficient and Optimal Growth Paths. *Rev Econ Stud* 1974;41:123–37. <http://www.jstor.org/stable/2296377>.
- [40] Natural Resources in the Theory of Production: The Georgescu-Roegen/Daly versus Solow/Stiglitz Controversy. *Archives-Ouvertes HAL-02332485* 2019. <https://doi.org/10.1080/09672567.2019.1679210>.
- [41] Germain M. Georgescu-Roegen versus Solow/Stiglitz: Back to a controversy. *Ecol Econ* 2019;160(168–182). <https://doi.org/10.1016/j.ecolecon.2019.01.012>.
- [42] Krysiak FC. Entropy, limits to growth, and the prospects for weak sustainability. *Ecol Econ* 2006;58:182–91. <https://doi.org/10.1016/j.ecolecon.2005.07.017>.
- [43] Stiglitz JE. REPLY Georgescu-Roegen versus Solow/Stiglitz. *Ecol Econ* 1997;22: 269–70.
- [44] Grassian D, Olsen DB. Practical Applications of Net Energy Analysis of Upstream Oil and Gas Processes. *J Energy Resour Technol*. JUNE 2021;143:064501-10. [http://asmedigitalcollection.asme.org/energyresources/article-pdf/143/6/064501/6578184/jert\\_143\\_6\\_064501.pdf](http://asmedigitalcollection.asme.org/energyresources/article-pdf/143/6/064501/6578184/jert_143_6_064501.pdf).
- [45] Georgescu-Roegen N. Energy Analysis and Economic Valuation. *South Econ J* 1979;45(4):1023–58. <http://www.jstor.org/stable/1056953>.
- [46] Daly HE, Farley J. *Ecological Economics: Principles And Applications*. (Island-Press, (2003).
- [47] IRENA (2020), Green Hydrogen Cost Reduction: Scaling up Electrolysers to Meet the 1.5°C Climate Goal, International Renewable Energy Agency, Abu Dhabi, (2020) (available at [www.irena.org/publications](http://www.irena.org/publications)).
- [48] Georgescu-Roegen N. *Chapter IX in, The Entropy Law and the Economic Process*. Cambridge: Harvard Univ. Press; 1971.
- [49] Georgescu-Roegen N., pag. 230 in *The Entropy Law and the Economic Process*, Harvard Univ. Press, Cambridge 1971.
- [50] Raugi M, Leccisi E. A comprehensive assessment of the energy performance of the full range of electricity generation technologies deployed in the United Kingdom. *Energy Policy* 2016;90:46–59. <https://doi.org/10.1016/j.enpol.2015.12.011>.
- [51] Colombatto S. Analisi energetica del Sistema elettrico nazionale e valutazione delle emissioni di CO<sub>2</sub> dirette ed indirette della filiera elettrica italiana. Master Thesis, Politecnico di Torino, Torino (Italy), a.y. 2018/2019. Available at <https://webthesis.biblio.polito.it/12364>.
- [52] Ruggeri B, Tommasi T, Sanfilippo S. *BioH<sub>2</sub> & BioCH<sub>4</sub> Through Anaerobic Digestion, From Research to Full-scale Applications*, Springer. London 2015. <https://doi.org/10.1007/978-1-4471-6431-9>.
- [53] Sanfilippo S, Raimondi A, Ruggeri B, Fino D. Dietary vs. transport: an analysis of environmental burdens pertaining to a typical workday. *Int J Consum Stud* 2012; 36:133–40. <https://doi.org/10.1111/j.1470-6431.2011.01079.x>.
- [54] Bargigli S, Raugi M, Ulgiati S. Comparison of thermodynamic and environmental indexes of natural gas, syngas and hydrogen production processes. *Energy* 2004;29: 2145–59. <https://doi.org/10.1016/j.energy.2004.03.018>.
- [55] SimaPro 9.1.1.1, Method Cumulative Energy Demand (LHV) 1.0, using the USLCL, ELCD, Ecoinvent 3 and Industry Data 2.0 databases.
- [56] OpenCA 1.10.3, Method Environmental Footprint (Mid-point indicator), using the EF secondary data 2019 database (i.e., the chosen items correspond to either EU 27 or EU28+3 datasets).
- [57] IEA, Today in Energy, EIA offers two approaches to compare renewable electricity generation with other sources August 22, 2019, at <https://www.eia.gov/todayinenergy/detail.php?id=41013> accessed 21/10/22.
- [58] Heijungs R, Suh S. The computational structure of life cycle assessment. *Springer Science* 2002. <https://doi.org/10.1007/978-94-015-9900-9>.
- [59] Adam R, Brandt AR. How Does Energy Resource Depletion Affect Prosperity? Mathematics of a Minimum Energy Return on Investment (EROI). *Biophys Econ Resour Qual* 2017;2:2. <https://doi.org/10.1007/s41247-017-0019-y>.
- [60] Carlos E, Gómez-Camacho CE, Ruggeri B. Energy Sustainability Analysis (ESA) of Energy-Producing Processes: A Case Study on Distributed H<sub>2</sub> Production. *Sustainability* 2019;11:4911. <https://doi.org/10.3390/su11184911>.
- [61] Bareiß K, De La Ruca C, Mocklb M, Hamachera T. Life cycle assessment of hydrogen from proton exchange membrane water electrolysis in future energy systems. *Appl Energy* 2019;237:862–72. <https://doi.org/10.1016/j.apenergy.2019.01.001>.
- [62] Mancera JJC, Manzano FS, Andújar JM, Vivas FJ, Calderón AJ. An Optimized Balance of Plant for a Medium-Size PEM Electrolyzer: Design, Control and Physical Implementation. *Electronics* 2020;9:871. <https://doi.org/10.3390/electronics9050871>.

- [63] Rahman MM, Oni AO, Gemechu E, Kumar A. Assessment of energy storage technologies: A review. *Energ Conver Manage* 2020;223:113295. <https://doi.org/10.1016/j.enconman.2020.113295>.
- [64] Jiao Y, Månsson D. Greenhouse gas emissions from hybrid energy storage systems in future 100% renewable power systems – A Swedish case based on consequential life cycle assessment. *J Storage Mater* 2023;57:106167. <https://doi.org/10.1016/j.est.2022.106167>.
- [65] “Sistemi di accumulo in Italia, i dati dell’energy storage 2021.” <https://www.rinnovabili.it/energia/sistemi-di-accumulo/sistemi-di-accumulo-energy-storage-2021/> (accessed Nov. 12, 2022).
- [66] Yadav D, Banerjee R. Net energy and carbon footprint analysis of solar hydrogen production from the high-temperature electrolysis process. *Appl Energy* 2020;262:114503. <https://doi.org/10.1016/j.apenergy.2020.114503>.
- [67] Orihuela MP, Espinoza E, Ripoll N, Chacartegui R, Toledo M. Natural gas-supported gasification of polyethylene and wood mixtures in a porous medium reactor. *Energ Conver Manage* 2021;233:113901. <https://doi.org/10.1016/j.enconman.2021.113901>.
- [68] Cheng F, Porter MD, Colosi LM. Is hydrothermal treatment coupled with carbon capture and storage an energy-producing negative emissions technology? *Energ Conver Manage* 2020;203:112252. <https://doi.org/10.1016/j.enconman.2019.112252>.
- [69] Dufur J, Serrano DP, Galvez JL, Gonzalez A, Soria E, Fierro JLG. Life cycle assessment of alternatives for hydrogen production from renewable and fossil sources. *Int J Hydrogen Energy* 2012;3(7):1173e1183. <http://doi.org/10.1016/j.ijhydene.2011.09.135>.
- [70] Fthenakis V, Leccisi E. Updated sustainability status of crystalline silicon-based photovoltaic systems: Life-cycle energy and environmental impact reduction trends. *Prog Photovolt Res Appl* 2021;29:1068–77. <https://doi.org/10.1002/pip.3441>.
- [71] Esmap. Global Photovoltaic Power Potential by Country. Washington, DC: World Bank; 2020. available at <https://globalsolaratlas.info/map?c=45.614037,-3.691406,4&s=42.996612,10.843506&m=site&pv=small,180,35,1>.
- [72] Bhandari KP, Collier JM, Ellingson RJ, Apul DS. Energy payback time (EPBT) and energy return on energy invested (EROI) of solar photovoltaic systems: A systematic review and meta-analysis. *Renew Sustain Energy Rev* 2015;47:133–41. <https://doi.org/10.1016/j.rser.2015.02.057>.
- [73] Jordan DC, Kurtz SR. Photovoltaic degradation rates-an analytical review. *Prog Photovolt Res Appl* 2013;21(1):12–29. <https://doi.org/10.1002/pip.1182>.
- [74] Gerbinet S, Belboom S, Léonard A. Life Cycle Analysis (LCA) of photovoltaic panels: A review. *Renew Sustain Energy Rev* 2014;38:747–53. <https://doi.org/10.1016/j.rser.2014.07.043>.