

Assessing the usability of GNSS on the way to the Moon: getting the LuGRE payload ready to fly

Original

Assessing the usability of GNSS on the way to the Moon: getting the LuGRE payload ready to fly / Doviš, Fabio; Nardin, Andrea; Minetto, Alex; Facchinetti, Claudia; Musmeci, Mario; Varacalli, Giancarlo; Parker, Joel J. K.; Konitzer, Lauren; Sanathanamurthy, Siddhartha; Valencia, Lisa; Miller, James J.; Bauer, Frank H.; Fantinato, Samuele; Miotti, Efer; Boschiero, Matilde; Pulliero, Matteo; Tedesco, Simone; Bernardi, Fabio; Guzzi, Salvatore. - ELETTRONICO. - (2023), pp. 1-9. (Intervento presentato al convegno 74th International Astronautical Congress (IAC) tenutosi a Baku, Azerbaijan nel 2-6 October 2023).

Availability:

This version is available at: 11583/2983287 since: 2023-10-24T07:29:00Z

Publisher:

International Astronautical Federation (IAF)

Published

DOI:

Terms of use:

This article is made available under terms and conditions as specified in the corresponding bibliographic description in the repository

Publisher copyright

IAF/IAF postprint versione editoriale/Version of Record

Manuscript presented at the 74th International Astronautical Congress (IAC), Baku, Azerbaijan, 2023. Copyright by IAF

(Article begins on next page)

IAC-23-B2.7.2

Assessing the Usability of GNSS on The Way To The Moon: Getting The LUGRE Payload Ready To Fly

Fabio Dovis^{a*}, Andrea Nardin^a, Alex Minetto^a, Claudia Facchinetti^b, Mario Musmeci^b, Giancarlo Varacalli^b, Joel J. K. Parker^c, Lauren Konitzer^c, Siddhartha Sanathanamurthy^c, Lisa Valencia^d, James J. Miller^e, Frank H. Bauer^f, Samuele Fantinato^g, Efer Miotti^g, Matilde Boschiero^g, Matteo Pulliero^g, Simone Tedesco^g, Fabio Bernardi^g, Salvatore Guzzi^g

^a *Department of Electronics and Telecommunications, Politecnico di Torino, 10129, Turin, Italy, name.surname@polito.it*

^b *Italian Space Agency, 00133, Rome, Italy, name.surname@asi.it*

^c *NASA Goddard Space Flight Center, Greenbelt, MD, USA, name.surname@nasa.gov*

^d *Overlook Systems, Inc., VA, USA*

^e *NASA Headquarters, Washington, DC, USA*

^f *FBauer Aerospace Consulting Services, MD, USA*

^g *Qascom Srl, Bassano del Grappa, 36061, Vicenza, Italy*

* Corresponding Author

Abstract

The use of in-orbit Global Navigation Satellite Systems (GNSS) in the Space Service Volume (SSV), beyond GEO altitudes, has become of great interest in view of the future missions to the Moon. Nevertheless, the usability of Earth GNSS at such distances has been proved only up to around 150,000 km away from the Earth's surface. In July 2020, the NASA-Italian Space Agency (ASI) Lunar GNSS Receiver Experiment (LuGRE) was selected as the 10th payload of CLPS Task Order 19D. In February 2021, NASA awarded this task order to Firefly Aerospace. Firefly's Blue Ghost Mission 1 (BGM1) will deliver LuGRE and the other CLPS 19D payloads to 18.6° N, 61.8° E in the Moon's Mare Crisium. The goal of the LuGRE project is to demonstrate the use of GNSS-based navigation and timing to the Moon, collecting and processing GNSS measurements along the mission. The payload, developed by Qascom srl, consists of a GNSS receiver specially designed and built for lunar applications, and it is based on their low altitude QN400-SPACE receiver product line. It will receive and process both Global Positioning System (GPS) and Galileo signals in the L1/E1 and L5/E5a bands, the results of which will be transmitted to Earth for further scientific processing. In fact, the Science Definition Team (SDT) of the LuGRE project worked in the past year to define a set of science and engineering investigations to be undertaken by the project. The SDT is currently composed by NASA and ASI scientists, these latter supported by researchers of Politecnico di Torino. These core investigations will be augmented by additional investigations proposed by the scientific community under the auspices of the full LuGRE Science Team, which is planned to be formed in 2023. The LuGRE payload was delivered to Firefly in February 2023, and it is going to be integrated on the BGM1 together with the other payloads of the mission.

Keywords: GNSS, Moon, GPS, Galileo, Receiver, Radionavigation, Lunar navigation

Acronyms/Abbreviations

Analog-to-Digital Converter	ADC
Commercial Lunar Payload Services	CLPS
Global Navigation Satellite Systems	GNSS
Engineering Model	EM
Electromagnetic Interference	EMI
Electromagnetic Compatibility	EMC
Engineering Qualification Model	EQM
Front-End Assembly	FEA
Full Functional Test	FFT
Flight Model	FM
In-phase Quadrature Samples	IQS

Italian Space Agency	ASI
Kennedy Space Center	KSC
Low Noise Amplifier	LNA
Lunar GNSS Receiver Experiment	LuGRE
Magnetospheric Multiscale	MMS
Moon Surface	MS
Moon Transfer Orbit	MTO
National Aeronautics and Space Administration	NASA
Principal Investigator	PI
Proto-Flight Model	PFM
Position, Velocity and Time	PVT
Science Definition Team	SDT
Software Defined Radio	SDR

Short Functional Test	SFT
Space Service Volume	SSV

1. Introduction

The use of in-orbit Global Navigation Satellite System (GNSS) receivers has been experimentally validated within the Space Service Volume (SSV), at LEO and MEO altitudes as well as up to GEO altitudes. Latest missions have unveiled GNSS performance for distances of about 190,000 km away from the Earth's surface. National Aeronautics and Space Administration (NASA)'s Magnetospheric Multiscale (MMS) mission has demonstrated the feasibility of tracking GPS signals up to such a distance [1]. MMS has demonstrated that future space missions can rely on GNSS even at very high altitudes, even if current GNSSs were not designed for non-terrestrial use.

The study of Earth GNSS signals beyond such altitude is still matter of research. This topic mostly relies on the knowledge gained from the use of GNSS on the Earth and on lower orbits.

Cis-lunar and lunar environments are becoming increasingly attractive as their investigation could represent the step forward in the exploration of Mars. In this scenario, it would be a great advantage to have a positioning system able to retrieve spacecrafts' position and used for navigation purposes by all the system elements on the Moon surface.

In the last years, many studies discussed the feasibility of using GNSS receivers along Moon Transfer Orbit (MTO) and lunar orbits. As an example, referring to the European Student Moon Orbiter mission, the work in [2] analysed the possibility of using GNSS navigation for Earth-to-Moon missions. In particular, this study investigated the GPS and Galileo signal availability and the achievable C/N0 levels, during different phases of the mission, considering an acquisition threshold of 35 dB-Hz. In order to extend the availability and the performance of the GNSS along the MTO, large effort has been devoted to the design of GNSS receivers able to deal with the space environment and with the GNSS signal as seen from space, [3][3][5][6].

However, so far no one of them had the chance to fly at altitudes beyond about 30 Radii Earth (RE), validating the simulated expected performance.

The Lunar GNSS Receiver Experiment (LuGRE) will be the first mission, once launched in 2024, to collect real GPS and Galileo measurements in transit between Earth and the Moon, in lunar orbit, and on the lunar surface, and will conduct onboard and ground-based navigation experiments using the collected data.

LuGRE is a joint NASA-Italian Space Agency (ASI) payload on the Firefly Blue Ghost Mission 1 (BGM1) which has the challenging goal of setting a new

milestone in the use of Earth GNSS in space, demonstrating GNSS-based positioning, navigation, and timing (PNT) at the Moon [8][9]. An overview of the mission and of the payload is provided in [10][11][12][13] and the main characteristics are recalled in Section 2.

The LuGRE GNSS receiver has been developed by Qascom srl. The receiver hardware and software configuration utilize previous flight heritage of Qascom's QN400 GNSS receiver product on space missions with ASI and NASA [14][15][16][17]. The QN400-SPACE receiver consists of a GPS/Galileo L1/L5 receiver specifically tailored for lunar applications. It is described in Section 3, together with the GNSS measurements provided by the payload. In Section 4 the testing and validation of the receiver and of the payload that has been taking place in the past year will be described.

The LuGRE payload was successfully delivered to Firefly in February 2023, and it is going now to be integrated on the BGM1 together with the other payloads of the mission.

As far as the preparation of the scientific part of the mission, in this paper we focus on the setting of the Science Team and the recent achievements in the preparation of the processing tools for the ground segment. In particular, we focus on the set of processing algorithms that are enabled by the capability of the receiver to collect raw digital samples of the GNSS signals in space, described in Section 5.

2. LuGRE Mission Overview

As previously introduced, LuGRE is a joint NASA-ASI payload on the Firefly's BGM1 and it is part of the NASA Commercial Lunar Payload Services (CLPS) program as one of ten NASA-funded payloads on its Task Order 19D, which was awarded to Firefly Aerospace, Inc. in 2021. The Firefly BGM1 will deliver these payloads to the Mare Crisium region of the Moon by 2024 and will operate on the surface for a minimum of 12 Earth days.

LuGRE is one of three technology development payloads on the flight, and is the only payload provided by NASA's Exploration Systems Development Mission Directorate (ESDMD). The LuGRE project is a partnership between NASA and ASI, with NASA providing the flight, the principal investigator (PI), and overall systems engineering and project management responsibilities, and ASI providing the co-PI, the payload hardware and software, and any payload-level testing and integration. Both partners will jointly operate the payload, receive, and analyze the data, and disseminate products and results.

Programmatically, LuGRE is classified as a "do no harm" mission, and so mission success is defined solely

by the requirement that the payload do no harm to the host spacecraft. Payload-level success, however, requires meeting all level 1 science requirements [10].

3. GNSS Measurements during the mission

The science investigations will be performed for a total of 15 hours both during the transit phase, the Moon Transfer Orbit and on the Moon surface.

Given the lander's helium budget, which must account for spacecraft slews for other purposes including the powered descent phase, LuGRE has been allocated 15 hours of total pointed time during the full transit phase, to include both commissioning and operational activities, and with a maximum continuous pointing duration of 1 hour. The LuGRE team has allocated these available operations time windows for the operations along the mission trajectory.

Once on the surface, LuGRE will be powered on within 3 hours of landing and will operate continuously for the full duration of the 12-day lunar surface operational period. During surface operations, and when powered during the lunar noon period, the payload will continuously track and downlink GNSS observables and navigation products.

3.1 GNSS Payload

The LuGRE payload has been designed as a robust, yet low-mass and power efficient payload able to withstand the harsh environments present in deep space, as well as the BGM1 lander dynamics.

The payload is composed of:

- A passive High-Gain Antenna (HGA), optimized for the GNSS L1/E1 and L5/E5a bands with a filtering stage.
- A Front-End Assembly (FEA), comprising a Low-Pass Filter (LPF), a Low Noise Amplifier (LNA), a Band Pass Filter (BPF) and an equalizer.
- A QN400-SPACE receiver, which is a GPS/Galileo dual-frequency (L1/L5) GNSS receiver designed in a dual cold redundant configuration, managed by a supervisory board.
- The harnesses connecting the various components.

The QN400-SPACE receiver is based on Qascom's GNSS receiver, which has been tailored for the LuGRE mission. In particular, it employs high sensitivity techniques to acquire and track both GPS L1 C/A and L5, and Galileo E1 and E5a open signals in lunar and cislunar environments. Moreover, the LuGRE receiver includes an orbital Kalman filter for accurate orbit determination, which will be used in MTO and Moon Surface (MS) for positioning estimation. It produces

both instantaneous, real-time and filter Position, Velocity, and Time (PVT) navigation solutions.

The core components of the QN400-SPACE receiver are:

- A baseband processor based on a Xilinx Zynq 7000 SoC, which includes an FPGA and a dual-core CPU;
- A Radio Frequency (RF) front-end, based on the Analog Devices AD9361.

These modules work in synch to capture RF signals and process them digitally. Qascom's receiver is based on the Software Defined Radio (SDR) technology, which allows for a certain software re-configurability. Moreover, it provides a high degree of flexibility in the resources allocated to the signals being processed. The receiver software can be fully or partially updated via telecommands sent from ground. This latter strategy has been specifically designed for space applications with limited uplink capability as in LuGRE.

The high sensitivity performance of the QN400-SPACE receiver is based on the signal acquisition and tracking processes. The acquisition aims at obtaining rough estimates in terms of Doppler and code phases of the received GNSS signals, which are then refined during the tracking stage. The High-Sensitivity acquisition algorithm implemented in the QN400-SPACE combines the coherent and non-coherent approach into a two-step hybrid framework. The main challenge interfering with the acquisition step derives from the power degradation of the signals received at increasing distance from Earth.

The tracking module tunes the estimates derived from the acquisition stage. During this process, the receiver's logic follows the signals dynamics, demodulates the navigation data bits and, eventually, generates the GNSS raw measurements, such as pseudorange, carrier phase, and C/N_0 .

In addition, the QN400-SPACE receiver is able to collect the signal raw In-phase/Quadrature (IQ) samples. These, once downlinked, can be later either replayed as input to a ground-based receiver or used for further signal processing analyses.

In conclusion, during the mission, the LuGRE receiver will provide:

- Both instantaneous, real-time and filter navigation solutions with Positioning, Velocity, and Timing (PVT).
- Orbit determination estimations, used to cope with the significant GDOP values encountered during the mission, in proximity of the Moon.
- GNSS raw observables of the tracked signals.
- Snapshots of Intermediate Frequency (IF) digital samples (IQ samples) collected by the RF front-end at L1/E1 and L5/E5 frequencies.

The data collected during the mission will drive different science investigations, since the receiver will operate both in-flight during the spacecraft Earth-Moon transfer and on the lunar surface.

4. Payload Qualification and Verification Process

The development of the LuGRE payload faced several challenges, including the global shortage of raw materials caused by the COVID-19 crisis, which led to significant delays in the delivery of components. In addition, the payload objective revolved around the complex task of acquiring and tracking GNSS signals at lunar distances. To ensure that the payload design met all operational and environmental requirements, an Assembly, Integration and Verification (AIV) process was implemented at all levels of assembly.

To validate the LuGRE system throughout the project lifecycle, each element of the payload was built in different prototypes. This approach was crucial in demonstrating the reliability, functionality, durability, and safety of the LuGRE system, ensuring its ability to withstand the extreme mission conditions. At various stages of the project, the models were subjected to various tests such as shock, vibration, thermal vacuum, electromagnetic interference (EMI), electromagnetic compatibility (EMC) and functional tests. Based on the test results, the design of the models and their manufacturing processes were updated accordingly.

The LuGRE payload was developed under an international agreement between the Italian Space Agency (ASI) and NASA as part of NASA's Artemis programme. The qualification test campaign followed the NASA-STD-7000A General Environmental Verification Standard (GEVS), which is related to the MIL-STD-461F standard. The verification process and documentation were derived from the ECSS-E-ST-10-02C Rev.1 standard [18].

The GEVS standard, commonly used in projects at NASA's Goddard Space Flight Center, has been adapted to create a LuGRE-specific verification and specification plan that follows a "Do No Harm" approach. It provides guidelines for verifying the environmental conditions of space programs and demonstrating compliance with project requirements through testing or analysis.

In the context of the LuGRE project, verification methods included testing, design review, analysis, and inspection in accordance with the GEVS and ECSS standards. Different methods were used to verify the same requirements at different stages of the project, allowing a comprehensive understanding of the system and end-to-end qualification. This approach ensured a complete assessment of the payload's maturity and maximum efficiency and reliability during the mission.

The test and verification process played a critical role in ensuring the correct functionality and performance of the LuGRE payload. To achieve this goal, a systematic and rigorous approach was used in the design, development and testing of all elements at two main levels. At the element level, specific test campaigns were designed to validate compliance with the technical specifications. At the payload level, the verification process was extended to include Engineering and/or Qualification Models (EM/EQM) and Flight and/or Proto-flight Models (PFM/FM) of all the payload elements.

4.1 Verification Process

Qascom was the qualification authority responsible for a comprehensive environmental and functional test campaign on the LuGRE GNSS receiver, while the other elements of the RF chain have been tested by their respective manufacturers. The entire payload was subjected to functional and interface testing at the NASA Goddard Space Flight Center facility to evaluate its performance in realistic mission scenarios. Firefly Aerospace, as the design authority for the lander, is responsible of end-to-end testing the payload functionality and its interface integration with the lander. Final pre-launch checks of the system will take place at the Kennedy Space Center (KSC) in preparation for flight.

The verification test campaign for the QN400-SPACE receiver focused on confirming its functional requirements and robustness in extreme environmental conditions. Two types of procedures were used: full functional test procedures (FFT) and short functional test procedures (SFT). The campaigns for the EQM and FM receivers followed a customized version of NASA's GEVS 7000A [24] and included qualification tests such as shock, sinusoidal, random, T-VAC and EMC/EMI measurements.

Verification of the LNA was carried out by dB Microwave and Qascom. The LNA qualification campaign was based on GEVS 7000A and tailored to the specific requirements of the LNA. Acceptance testing was performed together with the GNSS receiver.

The HGA verification included preliminary tests such as unit inspection, VSWR verification, radiation pattern and polarization purity verification. The protoflight campaign assessed the ability of the HGA to withstand the extreme environmental conditions of the LuGRE mission.

In addition, the LuGRE harness underwent an extensive qualification campaign, including separate batches of thermal exhaustion tests, as described in the verification approach.

In conclusion, the extensive qualification campaigns ensured the correct functioning and performance of the

LuGRE payload as a whole, as well as its individual elements. This approach, together with compliance with the relevant standards and guidelines, ensured the correct functioning of the system and its suitability for the mission, making the LuGRE payload ready to flight.

5. LuGRE Science Investigations

The general objective of the LuGRE project is to provide pieces of information that can be useful for future missions aiming at using GNSS-based navigation and timing to the Moon [25].

LuGRE will collect and process GNSS signals across the different mission phases, to fulfil the goals summarized as main science objectives. The first baseline goal is to receive GNSS signals at the Moon. The collected data, once returned to Earth will allow to characterize the lunar environment for the GNSS signals. A second objective is to demonstrate navigation and time estimation using GNSS data collected at the Moon, which would be, clearly, the first of its kind, establishing a major scientific milestone. The third objective is to use the collected data to support development of future GNSS receivers specific to lunar use, in light of the future missions to the Moon.

A LuGRE Science Definition Team (SDT) was formed in May 2021 for the purpose of proposing a concrete set of science and technology investigations to be executed by the LuGRE project. A primary outcome of the work of the LuGRE SDT is a set of specific, high-value, achievable investigations to be performed as part of the science program. The team worked through a multi-step process involving brainstorming, refinement, prioritization, documentation, and review. These investigations are prioritized including baseline experiments that allow the fulfilment of the abovementioned goals down to opportunistic science.

The LuGRE SDT will take care of the set of experiments that are inherently part of the mission and aim at fulfilling its objectives. However, the scientific investigations may be augmented further by the LuGRE SDT, either for implementation by the LuGRE project or by external participating investigators.

The LuGRE SDT's investigations can be broadly categorized into four levels of increasing processing complexity:

- *Signal Level:* This involves the basic collection of raw GNSS signal samples, followed by the post-

processing of these collected signals [19][20]. Additionally, it encompasses a low-level analysis of signal properties used in higher processing stages and the calibration of models used to simulate GNSS signal power and link budget throughout the mission and on the lunar surface.

- *Measurement Level:* At this stage, data is gathered in the form of GNSS observables, including pseudorange, Doppler shift, carrier phase, and local clock data.
- *Navigation Level:* This level focuses on the practical application of collected GNSS observables for navigation purposes. It also involves characterizing the performance of navigation throughout the mission and on the lunar surface [14]. Furthermore, it includes extrapolating achievable navigation performance for future missions based on observed properties of the collected observables.
- *Opportunistic Science:* This level encompasses potential unique scientific investigations that may occur, which may not necessarily fit the traditional navigation investigations. It involves using collected signals to study and draw conclusions about the environment in which they were collected.

5.1 The Processing of IQ Samples Data

During the mission operational windows, the LuGRE payload is able to collect both the measured observables and IQ signal samples (IQS), namely at both L1/E1 and L5/E5 carriers, according to the block diagram in Figure 1. In order to perform such investigations during the mission and in the following months a software analysis tool that was preliminary introduced in [13] is being developed. Figures 2 and 3 show examples of the graphical user interface of such analysis tool. A scaled version of it, addressing the most immediate experiments to be performed, is going to be integrated in the ground segment for a quick look analysis of the science results during the mission. Such tool will support the work of the SDT during the mission timespan.

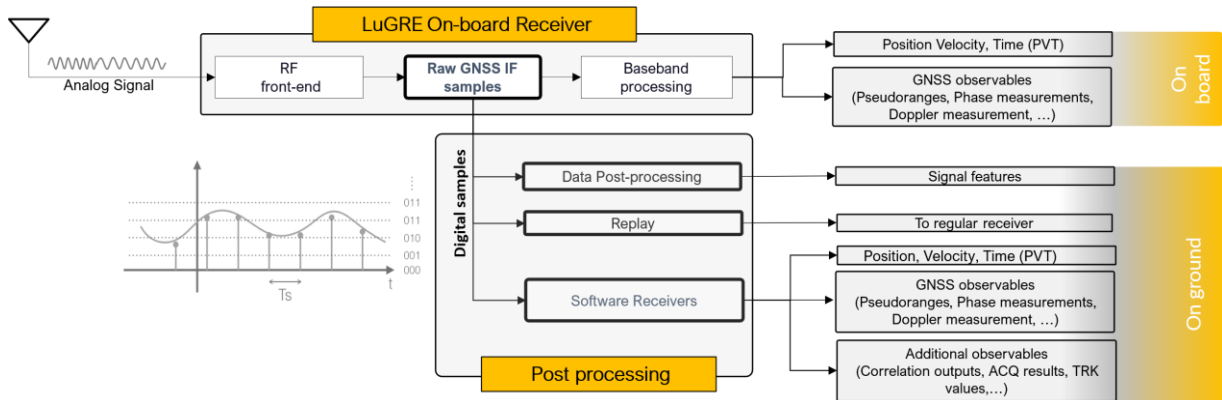

Fig. 1. Concept block diagram of the analysis tool interface for the IQS.

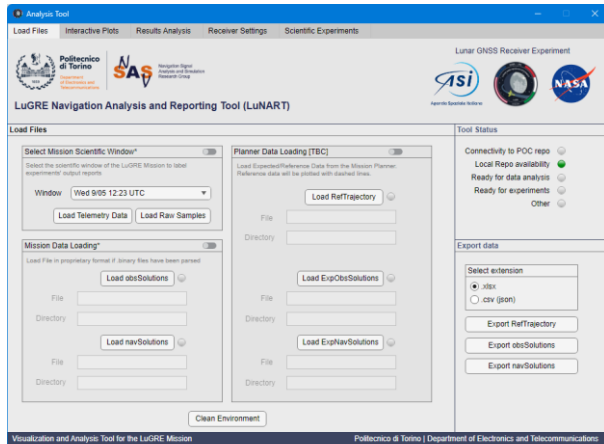

Fig. 2. Preliminary view of the LuGRE Navigation Analysis and Reporting Tool (LuNART) main configuration panel

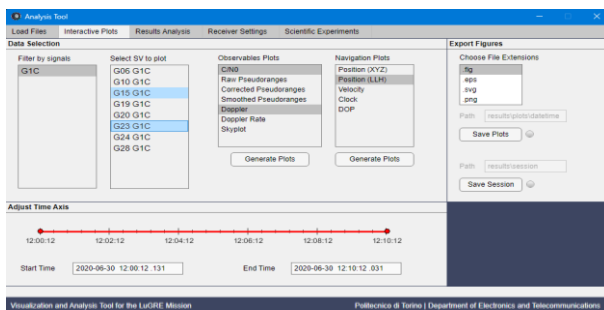

Fig. 3. Preliminary view of the LuGRE Navigation Analysis and Reporting Tool (LuNART) telemetry analysis and navigation tab

Among the scientific investigations, it is for sure of interest the use to the best extent as possible of the IQS, namely at both L1/E1 and L5/E5 carriers, that will be collected by the LuGRE payload during the operational windows. Recorded IQS will carry to ground the raw information of the actual GNSS signal as received in space.

The collection of raw GNSS digital signal samples—namely IQS—during the LuGRE mission operations, has been deemed as a valuable means to fulfil part of the mission goals. In particular, the recording of GNSS signal samples would foster the characterization of the lunar and cislunar GNSS signal environment as well as the development of future GNSS signal processing architecture suited to the lunar scenario.

IQS are baseband digital signal samples collected at the output of the LuGRE frontend and Analog-to-Digital Converter (ADC) and recorded separating In-phase and Quadrature components, as shown in Figure 4. This concept, borrowed from the Software Defined Radio (SDR) domain [21], enables the post-processing of signals collected at a very early stage of the receiver's processing chain and it is particularly suitable for critical environments with peculiar features that would be poorly modelled by signal simulators [22]. This approach opens up a wide range of possibilities for signal processing and science investigations, performed on-ground after data reception [23].

Indeed, before the LuGRE onboard receiver enters in its real-time operational mode, hence retrieving GNSS measurements and estimating its PVT solutions, digitized GNSS signals can be collected onboard and transferred to the ground segment to enable parallel investigation and further post-processing.

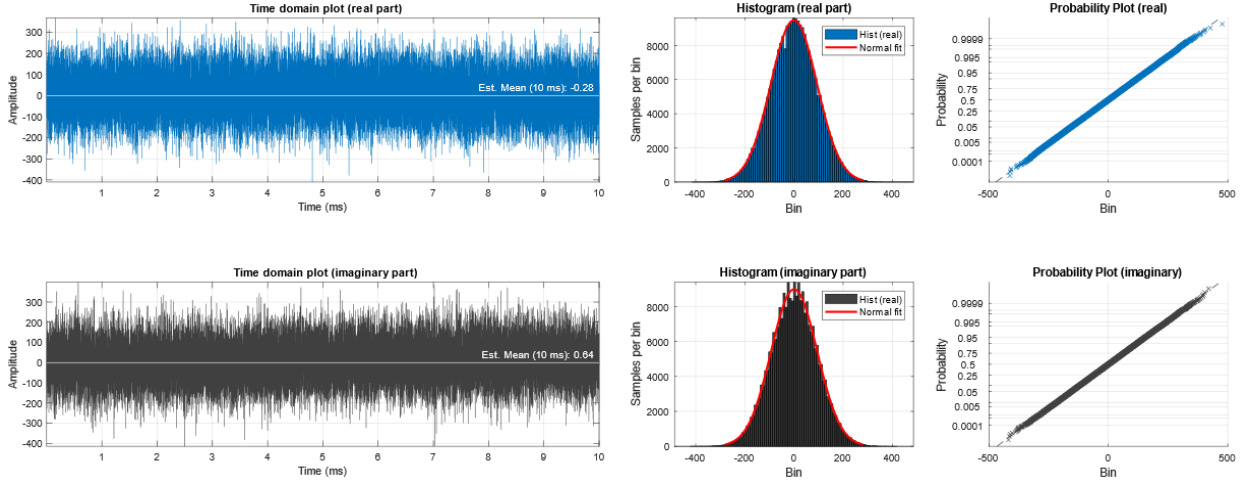

Fig. 4. Output visualization of the IQS pre-processing signal analysis showing ideal conditions on In-Phase and Quadrature signal components.

As also described in Figure 1, the collected IQS can be processed at different levels. Dedicated algorithms can be used for (i) data probing and analysis to extract and observe the signal features. Nonetheless, (ii) more structured GNSS software receivers can be used to compute GNSS observables, such as pseudoranges, phase and Doppler measurements, correlation outputs, acquisition and tracking results. The extend to which such observables can be constructed depends mostly on the IQS snapshot time-length [19][20]. For sufficiently long snapshots even PVT estimation could be performed—in a standalone fashion, or leveraging external navigation message information—but this will likely not be the case for the LuGRE mission, due the data collection constraints.

Due to the limited data volume manageable in terms of storage, data transfer window, and downlink capacity, the duration of the signal snapshot of IQS is limited and the corresponding data volume also depends on the sample rate and quantization depth. Preliminary tradeoff analyses [19][20] investigated desirable features and duration of such chunks of signals to maximize, given the constraints, their scientific return. They led to the result that at least 300-400 ms of snapshot duration are necessary to obtain a reasonable amount of chances of acquiring and tracking GPS and Galileo signals along the MTO while matching mission constraints.

IQS can be also leveraged to (iii) replay the digital signal to other GNSS receivers, further allowing to replicate the signal environment in different processing architectures. The IQS concept and its possibilities (i-iii) foster also a mission risk minimization approach, expanding the necessarily limited real-time processing solutions adopted onboard to an endless set of possible processing architectures, that can be tailored to the specific dataset under investigation.

Moreover, thanks to the reconfigurability of the software implementation, the latter can act both as a digital-twin of the on board receiver, and as a post processing tool to test different settings of the receiver parameters.

With this in mind, the ASI and Polito science teams, have been developed a set of algorithms and routines dedicated to IQS processing. This software tool provides a graphical user interface enabling a signal level inspection of the collected IQS data.

The In-phase and Quadrature branches of the digital signal can be plotted separately, as time sequences, to allow a visual monitoring of the amplitude levels. At this stage, the signal would be mostly buried in noise, but some considerations on the frontend and AGC characteristics may be done. An example is shown in Figure 4.

Aggregating the signal samples into histograms enables a useful observation of the noise characteristics. Indeed, as shown in Figure 4, a normal distribution of the noise-affected signal samples can be observed. The test is carried out through a best-fit routine, specifically using a Bayesian Inference Criterion (BIC) method to determine the best fitting for the observed probability density [26][27][28]. Complementary analysis can be pursued to further asses the nominal behaviour of the LuGRE receiver during the mission. The right-hand plots in Figure 4 compare the distribution of the captured samples to the normal distribution which is expected to characterize the nominal capture of noise-like signals such as the GNSS ones. This analysis shows the samples values using marker symbols and a reference line that represents the expected normal distribution. If the sample data has a normal distribution, then the data points appear along the reference line. The reference line connects the first and third quartiles of the data and extends to the ends of the

data. A distribution other than normal introduces curvature in the data plot.

6. Conclusions

In this paper, we presented the status of the LuGRE project, which is expected to fly to the Moon a GPS/Galileo receiver in 2024. The current and future activities up to the launch of the mission, focus on the development of the ground segment both for the payload operation as well as for the science investigations to be performed during and after the mission. In this paper, we provided an overview of the qualification and verification process of the payload, as well as of the science investigations focusing on the post-processing of the snapshot of GNSS digital signal samples collected by the on-board receiver.

References

- [1] National Aeronautics and Space Administration (NASA). MMS Orbit. [online].url: https://www.nasa.gov/mission_pages/mms/spacecraft/orbit.html
- [2] G. Palmerini, M. Sabatini, and G. Perrotta. «En route to the Moon using GNSS signals». In: *Acta Astronautica* 64 (Feb. 2009), pp. 467–483. doi: 10.1016/j.actaastro.2008.07.022.
- [3] V. Capuano, P. Blunt, C. Botteron, J. Tian, J. Leclère, Y. Wang, F. Basile, and P.-A. Farine. «Standalone GPS L1 C/A receiver for lunar missions». In: *Sensors* 16 (Mar. 2016), p. 347. doi: 10.3390/s16030347
- [4] P. Blunt, C. Botteron, V. Capuano, S. Ghamari, M. Rico, and P. Farine. “Ultra-high sensitivity state-of-the-art receiver for space applications” In: *Proceedings of Satellite Navigation Technologies and European Workshop on GNSS Signals and Signal Processing (NAVITEC), ESA Workshop*, Dec. 2016.
- [5] V. Capuano, P. Blunt, C. Botteron, and P.-A. Farine. «Orbital Filter Aiding of a High Sensitivity GPS Receiver for Lunar Missions». In: Jan. 2016. doi: 10.33012/2016.13422 (cit. on pp. 31, 52).
- [6] L. Musumeci, F. DAVIS, J. Silva, P.F. Silva, and H. Lopes. «Design of a High Sensitivity GNSS receiver for Lunar missions». In: *Advances in Space Research* 57 (Mar. 2016). doi: 10.1016/j.asr.2016.03.020
- [7] P. Giordano, M. Scotti, B. Kieniewicz, A. Delepaut, R. Swinden, C. Botteron, J. Ventura-Traveset. «NAVIMOON: Performance and Characteristics of GNSS Spaceborne Receiver in Representative Lunar Orbit». In *Proceedings of the 36th International Technical Meeting of the Satellite Division of The Institute of Navigation (ION GNSS+ 2023)*
- [8] Inside GNSS. Italy and Qascom to Land First GNSS Receiver on the Moon. [online]. url: <https://insidengss.com/italy-and-qascom-to-land-first-gnss-receiver-on-the-moon/>
- [9] G. Impresario, G. D’Amore, C. Stallo, L. Ansalone, and A. Tuozi. «GNSS and GALILEO for CIS-Lunar and Moon Navigation». In: 2018 IEEE 4th International Forum on Research and Technology for Society and Industry (RTSI). 2018, pp. 1–5. doi: 10.1109/RTSI.2018.8548504
- [10] J. Parker et al. The Lunar GNSS Receiver Experiment (LuGRE), *Proceedings of the International Technical Meeting 2022 ION ITM 2022*, January 25-27, 2022, pp. 420-437. <https://doi.org/10.33012/2022.18199>
- [11] S. Fantinato, E. Miotti, M. Boschiero, M. Bartolucci, M. Bergamin, D. Marcantonio, M. Pulliero, F. Rozzi, O. Pozzobon, C., Facchinetti, and M. Musumeci, “Development Challenges of a GNSS SDR Receiver for Moon Landing.” In *Proceedings of the 35th International Technical Meeting of the Satellite Division of The Institute of Navigation (ION GNSS+ 2022)*, pp. 602-627.
- [12] NASA, “NASA Selects Firefly Aerospace for Artemis Commercial Moon Delivery in 2023,” February 2021, <https://www.nasa.gov/press-release/nasa-selects-firefly-aerospace-for-artemis-commercial-moon-delivery-in-2023>
- [13] F. DAVIS, A. Minetto, A. Nardin, S. Guzzi, S. Zocca, O. Vouch, G. Impresario, M. Musumeci, C. Facchinetti, G. D’Amore, L. Ansalone, M. Amoroso. “The LuGRE project: a scientific opportunity to study GNSS signals at the Moon” (2022) *Proceedings of the International Astronautical Congress, IAC, 2022-September*.
- [14] R. Longo, M. Bartolucci, F. Longhi, M. Bergamin, S. Fantinato, O. Pozzobon, J.J. Miller, L. Valencia, E. Magnuson, P. De Leon, and B. Flaherty, “GARHEO Flight Experiment to Test GPS-Galileo Interoperability to Support Launchers and Space Missions.” In *Proceedings of the 33rd International Technical Meeting of the Satellite Division of The Institute of Navigation (ION GNSS+ 2020)* (pp. 1301-1317)
- [15] K. Croissant, G. Jenkins, R. McKnight, B.C. Peters, S. Ugazio, and F. van Graas, “Bobcat-1, the Ohio University CubeSat: preliminary data analysis.” In *Proceedings of the 2021 International Technical Meeting of The Institute of Navigation* (pp. 625-636)
- [16] S. Ugazio, Z. Arnett, R. McKnight, and B.C. Peters, “Receiver-Specific GNSS Inter-System Bias in Low Earth Orbit.” In *Proceedings of the 2023 International Technical Meeting of The Institute of Navigation* (pp. 831-843)

- [17] W. Enderle, E. Schönemann, F. Gini, M. Otten, P. Giordano, J.J. Miller, O.S. Sands, D. Chelmins, and O. Pozzobon, "The joint ESA/NASA Galileo/GPS Receiver Onboard the ISS–The GARISS Project". In *Proceedings of the 32nd International Technical Meeting of the Satellite Division of The Institute of Navigation (ION GNSS+ 2019)* (pp. 1147-1156)
- [18] European Cooperation for Space Standardization, ECSS-E-ST-10-02C Rev.1 – Verification, Version 01/02/2018), Available at <https://ecss.nl/standard/ecss-e-st-10-02c-rev-1-verification-1-february-2018/>, Accessed on 05/30/2023
- [19] A. Nardin, A. Minetto, O. Vouch, M. Mariani, and F. Dovis, "Snapshot acquisition of GNSS signals in space: a case study at lunar distances." In *Proceedings of the 35th International Technical Meeting of the Satellite Division of The Institute of Navigation (ION GNSS+ 2022)* (pp. 3603-3617).
- [20] A. Nardin, A. Minetto, S. Guzzi, F. Dovis, L-Konitzer, J. K. Parker, "Snapshot Tracking of GNSS Signals in Space: A Case Study at Lunar Distances." In *Proceedings of the 36th International Technical Meeting of the Satellite Division of The Institute of Navigation (ION GNSS+ 2023)*
- [21] J. Kaderka and T. Urbanec, "Time and sample rate synchronization of RTL-SDR using a GPS receiver," *2020 30th International Conference Radioelektronika (RADIOELEKTRONIKA)*, Bratislava, Slovakia, 2020, pp. 1-4, doi: 10.1109/RADIOELEKTRONIKA49387.2020.9092398.
- [22] N. Linty, F. Dovis, and L. Alfonsi, Software-defined radio technology for GNSS scintillation analysis: bring Antarctica to the lab. *GPS Solutions*, 22(4), 1-12
- [23] A. Minetto, F. Dovis, A. Nardin, O. Vouch, G. Impresario, and M. Musmeci, "Analysis of GNSS data at the moon for the LuGRE project," in *2022 IEEE 9th International Workshop on Metrology for AeroSpace, MetroAeroSpace 2022 - Proceedings*, 2022. doi: 10.1109/MetroAeroSpace54187.2022.9855945 pp. 134–139.
- [24] NASA Technical Standards System (NTTS), General Environmental Verification Standard (GEVS) for GSFC Flight Programs and Projects, GSFC-STD-7000, Version 04/28/2021, Available at <https://standards.nasa.gov/standard/GSFC/GSFC-STD-7000>, Accessed on 05/30/2023
- [25] O. Vouch, A. Nardin, A. Minetto, M. Valvano, S. Zocca, F. Dovis. A Customized EKF model for GNSS-based Navigation in the Harsh Space Environment. In *IEEE Wireless in Space and Extreme Environments (WiSEE) 2023*, Aveiro, Portugal, September 2023.
- [26] Johnson, N. L., S. Kotz, and N. Balakrishnan. *Continuous Univariate Distributions. Vol. 1*, Hoboken, NJ: Wiley-Interscience, 1993.
- [27] Johnson, N. L., S. Kotz, and N. Balakrishnan. *Continuous Univariate Distributions. Vol. 2*, Hoboken, NJ: Wiley-Interscience, 1994.
- [28] Bowman, A. W., and A. Azzalini. *Applied Smoothing Techniques for Data Analysis*. New York: Oxford University Press, 1997.