

Design of a Test Section for the Experimental Investigation of the WCLL Manifold Hydraulic Features

Original

Design of a Test Section for the Experimental Investigation of the WCLL Manifold Hydraulic Features / Collaku, A., Arena, P., Del Nevo, A., Marinari, R., Savoldi, L.. - In: ENERGIES. - ISSN 1996-1073. - ELETTRONICO. - 16:5(2023). [10.3390/en16052246]

Availability:

This version is available at: 11583/2979352 since: 2023-06-13T17:00:51Z

Publisher:

MDPI

Published

DOI:10.3390/en16052246

Terms of use:

This article is made available under terms and conditions as specified in the corresponding bibliographic description in the repository

Publisher copyright

(Article begins on next page)

Article

Design of a Test Section for the Experimental Investigation of the WCLL Manifold Hydraulic Features

Aldo Collaku ¹, Pietro Arena ², Alessandro Del Nevo ², Ranieri Marinari ^{2,*} and Laura Savoldi ¹¹ MAHTEP Group, Dipartimento Energia “Galileo Ferraris”, Politecnico di Torino, 10129 Turin, Italy² Department of Fusion and Technology for Nuclear Safety and Security, Italian National Agency for New Technologies, Energy and Sustainable Economic Development (ENEA), 40032 Camugnano, Italy

* Correspondence: ranieri.marinari@enea.it

Abstract: A scaled-down test section representative of an Outboard Segment manifold of the Water-Cooled Lithium Lead Breeding Blanket for the European DEMO has been designed for installation and test in a high-mass flow branch of the W-HYDRA facility, under construction at the premises of ENEA Brasimone Research Center. The test section should confirm the flow repartition recently computed in the different breeding units on the full-scale manifold, validating at the same time the computational tools used for the design and analysis. The detailed objectives and requirements of the test section, as well as the scaling rationale and procedure adopted for its design, are presented in the paper. The final design of the test section is discussed. The preliminary analyses of the developed design are also presented and show that it is compliant with the initial objectives.

Keywords: water technology for DEMO; experiments; WCLL; manifold; thermal hydraulics; CFD



Citation: Collaku, A.; Arena, P.; Del Nevo, A.; Marinari, R.; Savoldi, L. Design of a Test Section for the Experimental Investigation of the WCLL Manifold Hydraulic Features. *Energies* **2023**, *16*, 2246. <https://doi.org/10.3390/en16052246>

Academic Editor: Enrico Nobile

Received: 13 January 2023

Revised: 10 February 2023

Accepted: 24 February 2023

Published: 26 February 2023



Copyright: © 2023 by the authors. Licensee MDPI, Basel, Switzerland. This article is an open access article distributed under the terms and conditions of the Creative Commons Attribution (CC BY) license (<https://creativecommons.org/licenses/by/4.0/>).

1. Introduction

In the framework of the design activities in preparation for the EU-DEMO [1], the ENEA Brasimone Research Center is supporting the design and realization of an experimental infrastructure called W-HYDRA, dedicated to the investigation of the water and lithium-lead technologies applied to the DEMO Breeding Blanket (BB) [2] and Balance of Plant (BoP) [3] systems.

A high-mass flow branch of the W-HYDRA infrastructure is a water loop facility dedicated to the experimental investigation of the DEMO Water Cooled Lead Lithium (WCLL) BB components and BoP Steam Generator [4]. One of the objectives of the water loop facility-HYDRA is to host different BB mock-ups to experimentally assess both their design and performance.

One of the key components of the WCLL design is the manifold system [5]. The current in-Vacuum Vessel coolant systems consist of inlet and outlet feeding pipes, as well as the manifolds. The formers oversee either routing the cold coolant (subcooled water at 15.5 MPa and 295 °C) to the different BB segments (inlet pipes) or collecting the hot water to the steam generator (outlet pipes). The manifolds are devoted to distributing the water coolant to the different channels and tubes inside the blanket breeding units (BUs) and finally recollecting it. Each BU is equipped with a set of 7 Double-Wall Tubes (DWTs) in parallel connecting the Inlet Manifold (IM) to a first Recirculation Manifold (REC1), while a set of additional 4 DWTs in parallel connects a second Recirculation Manifold (REC2) to the Outlet Manifold (OM), as shown in Figure 1 [2]. The two REC manifolds, serving mainly as a fluid buffer, are then connected through a series of circular channels.

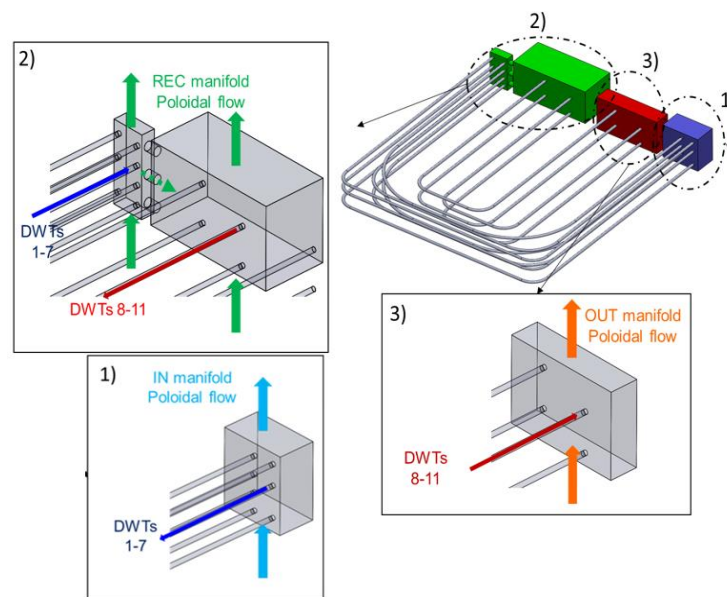

Figure 1. Schematic view of the DWT system within a single BU of the EU-DEMO WCLL. (1) highlight of the inlet manifold (IN), (2) highlight of the two recirculation manifolds, (3) highlight of the outlet manifold (OUT).

A detailed investigation of the manifolds of an OutBoard (OB) Segment of the WCLL has been reported in [6], where a hybrid CFD approach has been adopted to compute the flow repartition in the 104 BUs along the manifolds. Within the hybrid approach, the DWTs in each BU have been substituted by equivalent porous pipes, to decrease the computational burden, see Figure 2. The result of the analysis showed that, notwithstanding the manifold tapering along their length, the flow repartition suffers by a significant deviation from the expected average value.

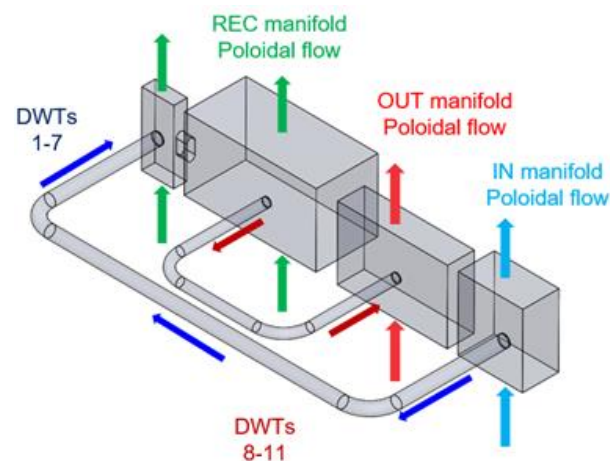

Figure 2. Lumped approach to the model of a single BU, with the DWTs substituted by two equivalent porous pipes to mimic the DWTs 1–7 (connecting IM to REC1) and DWTs 8–11 (connecting REC2 to OM), respectively.

To further investigate this issue, the high mass flow branch of W-HYDRA will host a test section devoted to experimentally assessing the hydraulic behavior of the WCLL manifold system. The test section should be a mock-up of the manifold, properly down-scaled to preserve the representativeness of the original component.

Scaling analysis is a theoretical procedure to make sure that experimental results are applicable to prototype conditions. Nuclear safety technology is often based on information

obtained from scaled experiments such as the PKL facility in Germany [7] or the LSFT facility in Japan [8]. Note that, in the case of scaled experiments, it is necessary to show how the experimental results can be transferred or applied to real, prototypical reactor conditions.

Generally speaking, scaled facilities have advantages (lower costs, phenomenon and plant commissioning simplification, etc.) and drawbacks (geometry deformations, distorted or absent phenomena in small-scale components, different boundary layer behavior) [9] and the optimized scaling approach is strictly linked to the objectives of the experimental campaign.

The present paper aims at presenting the experimental facility that will host the mock-up, the main objectives of the experimental campaign on the manifold mock-up that led to the design criteria adopted for the component, and at describing the resulting design. Additionally, the design analytical calculations are presented, followed by CFD numerical results for the hydraulic optimization of the water flow inside the test section. A section is also dedicated to the description of the instrumentation foreseen.

2. W-HYDRA: The Water Loop High Power Branch

A new multipurpose experimental infrastructure is currently under design at ENEA Brasimone Research Centre. One of the facilities is a high-power branch side of a Water Loop (WL) called STEAM. This facility will investigate the DEMO balance of the plant water cooling system in steady state and transient scenarios. STEAM will have two thermally coupled loops: a primary side working with single-phase (liquid) water at 15.5 MPa and a secondary side working with two-phase pressurized water at 6.41 MPa. The nominal thermal power of the facility is 3.1 MW.

The manifold mock-up will be installed on the primary loop system of the facility. The main parameters of the loop are reported in Table 1.

Table 1. Main parameters of the STEAM facility.

Parameter	Unit	Value
P	kW	3000
pH ₂ O,l	MPa	15.5
TH ₂ O,in,l	°C	328
TH ₂ O,out,l	°C	295
ΓH ₂ O,l	kg/s	15.53
ΓH ₂ O,max	kg/s	20.0

The primary loop will be equipped with a steam generator, a 3.1 MW heating system, a circulation pump, and a pressurizer (Figure 3). The manifold mock-up (or Test Section 2) will be installed across the hot and cold leg as the Steam Generator (Figure 4).

The manifold mock-up will mainly consist of six parts:

- the Inlet Manifold (IM) fed by STEAM hot leg,
- the Recirculation manifold (REC),
- a first rank of pipe assembly, moving from the inlet to the recirculation manifold,
- the outlet Manifold (OM) linked to the downstream STEAM cold leg
- a second rank of BZ pipe assembly, moving from the recirculation manifold to the outlet manifold
- Instrumentation: mass flow meters and differential pressure transducers.

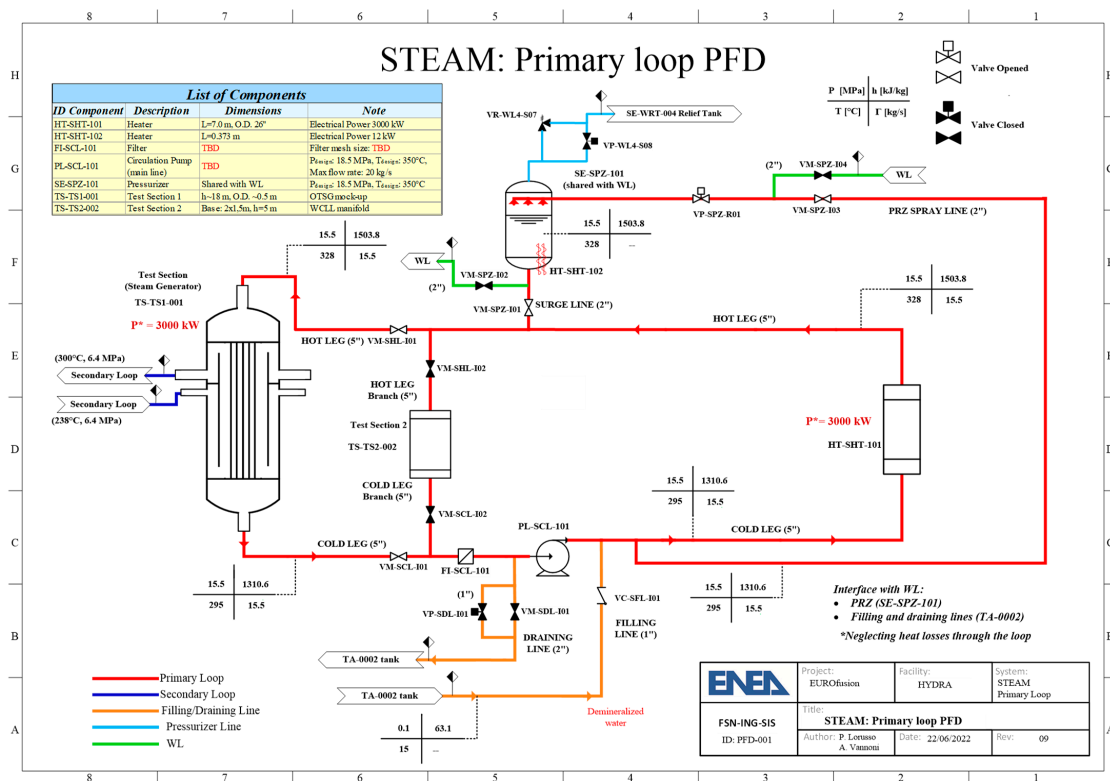

Figure 3. Process Flow Diagram (PFD) of the STEAM primary loop, the manifold mock-up location is represented in the scheme as a black rectangle called “Test Section 2”, main circulation pump (PL-SCL-101) and main electric heater (HT-SHT-101) are illustrated together with the loop thermal-hydraulic parameters.

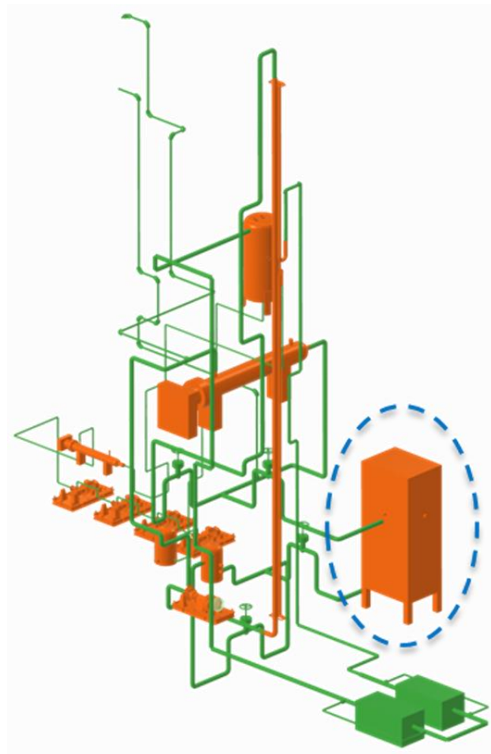

Figure 4. Sketch of the STEAM facility: the electrical heater is horizontally placed; the Steam Generator is the longest vertical component while the manifold mock up is highlighted in the dashed circle.

3. Design of the Manifold Mock-Up

This section contains a general description of the mock-up, including the constraints coming from the W-HYDRA infrastructure and its scaling rationale from the full-size component to comply with the test objectives.

3.1. Mock-Up Test Objectives

The test section should be a scaled representation or a segment of the full-size manifold with the main goal of studying the manifold hydraulic behavior under different operative conditions. More in detail, the tests should allow to:

1. Measure the mass flow rate distribution in the BU along the manifold, and
2. Demonstrate, by measuring the mass flow rate distribution in the Breeding Zone (BZ) tubes, that the manifolds feed the BZ tubes along the manifold according to design technical specifications, and/or quantify the deviation from it;
3. Produce experimental data (e.g., mass flow and pressure drop distribution along and across the manifold test section when the mass flow is varied) to qualify 1-D Thermal hydraulic codes (RELAP5, GETTHEM, ...) and CFD codes (ANSYS, STARCCM+, ...), see [10,11].
4. Possibly investigate and measure the 3D flow behavior inside the different manifolds with highlights on: flow development and recirculation which may induce flow distortions and uneven mass flow distribution;

3.2. Constraints from the Test Facility

The WCLL manifold test section is a water-circulating component, it shall be scaled and designed based on the following requirements:

- The manifold test section shall be designed to qualify the lumped parameter modeling approach (equivalent channel model) for First Wall (FW) channels and BZ tubes as adopted in [6];
- The maximum available working pressure is 18.5 MPa;
- The maximum available working temperature is 350 °C;
- The maximum available footprint for the test section is 2 m × 1.5 m;
- The maximum available height of the test section is 13 m;
- The maximum available mass flow is 20 kg/s;
- The maximum pressure drop is 0.15 MPa across the test section;
- The test section shall be coupled with the STEAM facility with a flanged connection of 5'' class 2500;
- The test section shall be an isothermal (zero-input power) component, heat losses through the component shall be reduced to an extent such as the maximum temperature loss along the manifold remains below 3 °C (about 300 kW);
- The maximum number of available signals to be acquired at the same time from the manifold test section is 50.

3.3. Scaling Procedure

The flow repartition among the different BUs along the manifold, presented in [6], is strictly related to the cross-section of the manifolds, which is not constant along the fluid path. The connection of the parallel pipes to the manifold is a classical Z-connection [12], where homogeneous flow repartition could be achieved by a proper tapering of the manifolds [13]. As a matter of fact, the IM and OM cross-section along the fluid path are tapered, as clearly visible in Figure 5. The recirculation manifold, however, keeps their cross-section constant up to about 2/3 of the curvilinear coordinate along the fluid path (Figure 5), where a sudden contraction occurs in view of a space constraint due to the presence of a spinal manifold in the posterior part of the Back-Supporting Structure [2]. Since the interaction between the manifold size determines the flow repartition, this peculiarity must be preserved if the same flow repartition as in the full-scale manifold is targeted in the test section mock-up.

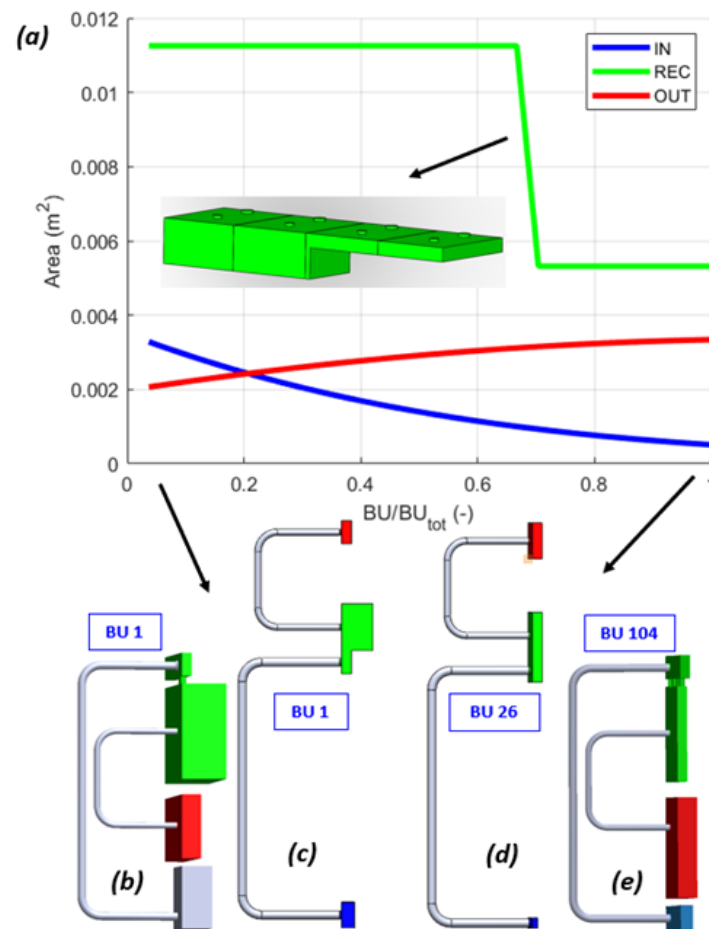

Figure 5. (a) Variation of the cross-section of the IM, REC (total) and OM along the fluid path, for the mock-up of the manifold of the OB segment (reduced to $\frac{1}{2}$ for symmetry reasons). The inset shows the sudden change in the REC cross-section along the manifold. (b) first Breeding Unit of the full size manifold compared to the first Breeding Unit of the mock-up (c), see the different manifolds shape. (d) last Breeding Unit of the manifold mock-up and last Breeding Unit of the full size manifold (e), the different shape of the green recirculation manifold is perfectly illustrated.

Different strategies have been investigated for the scaling down but discarded. One of them was to keep the same Reynolds (Re) and Euler (Eu) numbers in the manifolds; unfortunately this strategy led to very small manifolds dimension (the flow area of the manifolds would be scaled by a factor of 16 obtaining a component of few mm per latum) that could not be manufactured. To overcome this issue, one may think of analyzing a slice of the full geometry, maintaining the original size, but at that point, the verification of the full-size Z-shape mass flow trend of the full-size component would have been impossible.

In the end, it was decided to keep the same velocity profile along the manifolds and scaling the mass flow rate and the cross-section area by the same scaling factor, equal to 4. In this way, since the mass flow rate in (one half of) the symmetric full-size manifold is ~ 64 kg/s, the mass flow through the mock-up will be one-fourth (16 kg/s), the number of the BUs in the mock-up could be scaled in the same way to $\frac{1}{4}$ of the original values (26 BUs), about the other dimensions, the mock-up “poloidal” length is 4 m ($\frac{1}{4}$ of the full-size component), the pitch between adjacent BUs was kept as 153 mm as the desired average mass flow value in each simulated BU (0.615 kg/s).

To further simplify the manufacture of the test section, the curvature of the full-size manifold is discarded, and the pipes connecting the REC to the OM are not nested within the pipes connecting the IM to the REC, as shown in Figure 6. All the manifold cross-section has been reduced by a factor of 4, to maintain the same velocity along the manifolds, scaling

both dimensions by a factor $\frac{1}{2}$, and the IM and OM are tapered according to the original full-scale design. The 7 + 4 DWTs of the full-scale design have been lumped in the mock-up in two equivalent pipes, as already conducted in the analysis of [14]. Since the diameter of the pipes has been calibrated there to give the same cross-section of the DWTs 1–7 (1" sch 160 pipe connecting the IM to the REC) and of the DWTs 8–11 (3/4" sch 160 pipe connecting the REC to the OM), the same dimensions have been preserved here. The equivalent pipes will be tuned in length or equipped with an orifice to give the same pressure drop at the nominal flow rate as the bundle of DWTs (see [14] for details). Preliminary evaluations show that an orifice of 15 mm in diameter should allow to reach a comparable pressure drop to the DWTs 1–7 (the actual length of which is ~1.65 m, with the two 90° bends shown in Figure 1), while a 13 mm diameter orifice would allow mimicking the DWTs 8–11 (actual length of ~1.2 m).

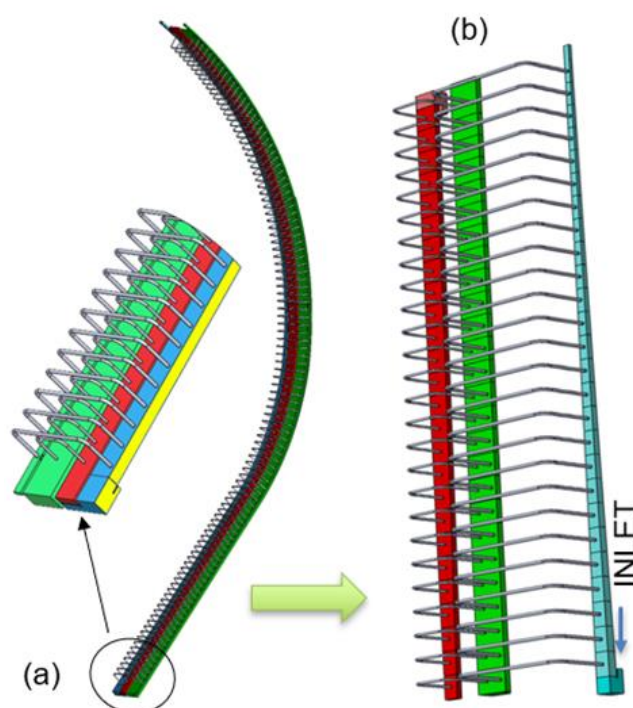

Figure 6. Schematic view of (a) the layout of the full-size OB manifolds [picture modified from ref. [6], with the DWTs lumped in equivalent porous pipes, and (b) of the test section under design.

This scaling approach ensures that the Re in the Equivalent Porous Pipes (EPPs) is preserved, keeping unmodified the EPP geometry, mass flow rates, and fluid properties. In particular, the calculated Re in the EPPs are in the range of $3 \times 10^5 \div 6 \times 10^5$ (fully turbulent flow regime). Furthermore, concerning the Euler number, evaluated as $Eu = \Delta P / (1/2 \rho v^2)$, in the EPP it remains as in the full-size tubes, since the Re number, geometry, properties, and velocity have been preserved. As a drawback, note that the adopted scaling factor for the manifold cross-section leads to a hydraulic diameter for the manifold in the test section halved with respect to the full-size manifold, so that the Reynolds number in the manifolds for the scaled geometry ($\leq 3 \times 10^6$) results to be half the original one. Similarly, the estimate of Eu across the entire muck-up returns to be 37% lower than the value of the full-size object.

The REC2, peculiar to the full-scale model, has been scaled down on its flow area by a factor of $\frac{1}{2}$, such as the IM and OM, and compacted with the REC1 in a single manifold (REC), as shown in Figure 7. This simplification has been performed to avoid the need of manufacturing undersized components, for the REC1, and to avoid jet effects from REC1 to REC2 that were not seen in the original structure but can affect the hydraulic behavior of

the scaled mock-up. This detail can be also seen in Figure 5c,d, if compared to the full-size manifolds (Figure 5b,e, respectively).

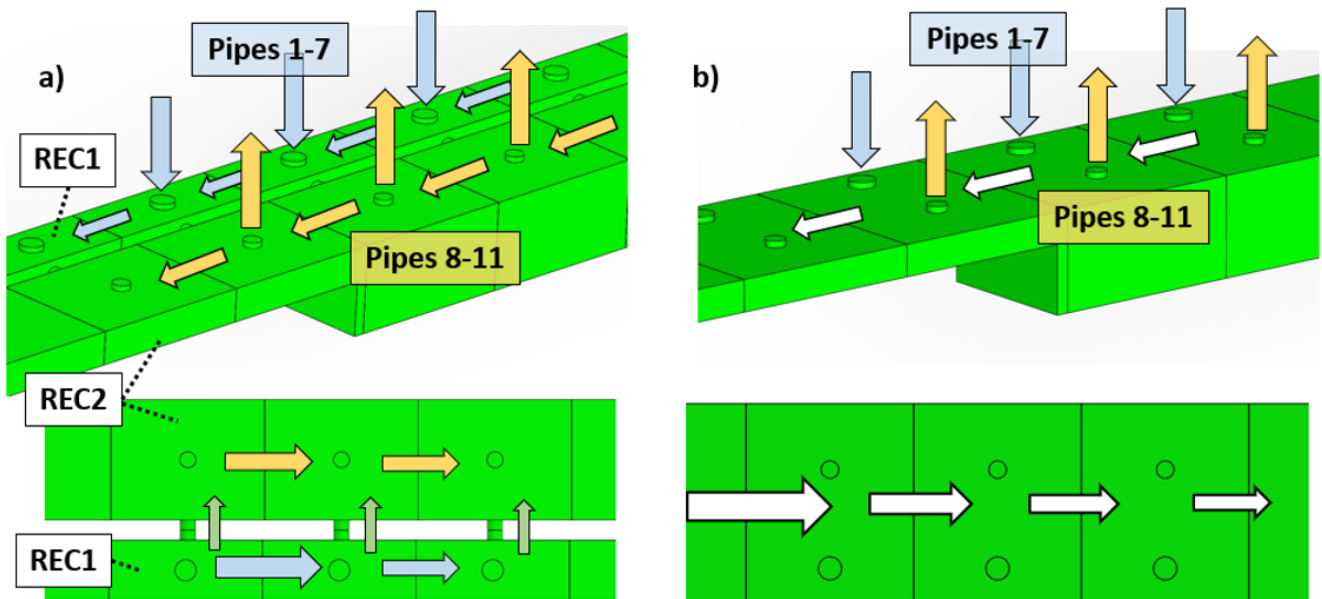

Figure 7. CAD of the REC1 and REC2 before (a) and after (b) the merging.

4. Mock-Up Analysis

To verify the consistency of the mock-up design obtained just with back-of-the-envelope considerations, a detailed 3D CFD computational model has been developed and simulations have been carried out to compare the flow rate repartition in the 26 BUs of the mock-up with that of the full-scale component (104 BUs). The analysis is restricted here to the fluid domain and the developed model is a hybrid one, where the DWTs are lumped in equivalent porous pipes, reproducing what has been conducted in [6], using also in this case the STAR-CCM+ commercial software [14].

4.1. Simulation Set-Up

Since the flow in the manifolds is expected to achieve turbulent conditions at least for the nominal value of the flow rate (i.e., in the first portion of the IM and last portion of the OM), the κ - ω Shear Stress Transport (SST) turbulence model has been selected, together with the γ -transition model, which is capable to give reliable results throughout the transition regime down to the laminar one, expected at the end of the IM and beginning of the OM. The κ - ω SST model [15] is widely adopted in engineering problems with complex geometries since it is suitable for modeling accurately the boundary layers under adverse pressure gradients. An all y^+ wall treatment is selected.

For the equivalent porous pipes, their hydraulic characteristic has been calibrated using the Darcy-Forchheimer formulation for the pressure gradient based on a dedicated CFD analysis of the DWTs bundles, and the recipe has been validated in [6].

The grid has been developed starting from that in [6], with five prism layers at the wall and first cell thickness of 10^{-3} mm. Polyhedral cells with a base size of 3 mm have been adopted in the core flow, reduced to 0.75 mm in correspondence to the pipes to better represent entering and jet effects. Extrusion of the mesh from the manifolds is adopted in the equivalent porous pipes. The resulting grid is made of 33 MCell, some details can be found in Figure 8. The grid has been proven to allow computing grid-independent results (not shown).

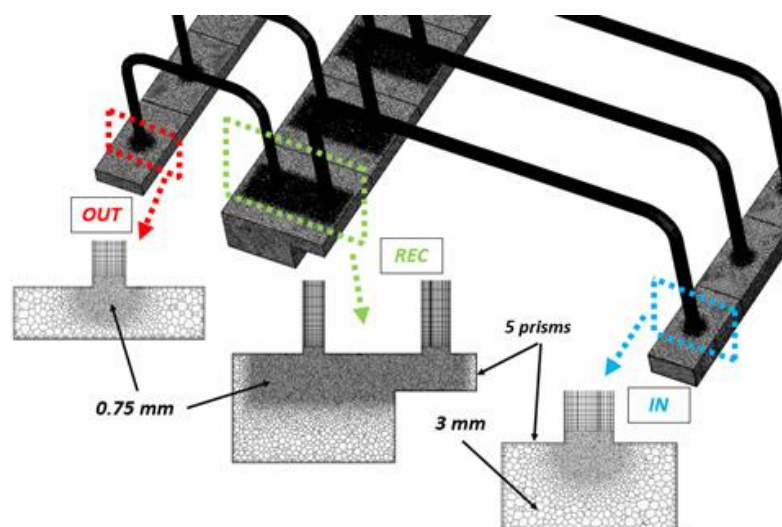

Figure 8. Zoom of the grid adopted for the simulation of the fluid domain of the manifold mock-up.

The total mass flow rate, scaled-down to 16 kg/s (factor of 1/4) has been used as an inlet boundary condition (imposed on the back of the inlet manifold, to also reproduce the flow curvature upstream of the first BU, see Figure 6), with a reference pressure for the incompressible fluid set at 15.5 MPa and a gauge pressure of 0 Pa imposed at the outlet. The simulation is steady-state and a segregated solver has been selected. The operating fluid is liquid water and its constant thermophysical properties have been evaluated with IAPWS-IF97 formulation at 15.5 MPa and 313 °C (foreseen average temperature of water in WCLL operating conditions), values compliant with the facility constraints (par. 2.2).

4.2. Results and Check of Representativeness

The results obtained from the CFD analysis on the mock-up design show a good agreement with the CFD results of the full-size geometry in [6]. The logic of the scaling down was to maintain the same velocity profile along the manifolds and the results reported in Figure 9 show good agreement with the behavior of the full-size component and the correctness of the scaling. The velocities have been extracted from the CFD simulation as velocity average values at selected manifold cross-sections, located at the beginning of each BU.

One of the objectives of the mock-up is to investigate the mass flow rate repartition along the manifolds: the numerical results on the mock-up present the same trend of the full-size geometry as visible in Figure 10. The mass flow trend similarity ensures that the suction phenomenon responsible for the Z-manifold mass flow rate distribution in the full-size geometry is correctly reproduced in the mock-up. The mass flow rate values have been extracted from the simulation on cross-sections located in the middle of the tubes as performed in the full-size geometry CFD simulation. The mass flow rates in the first EPPs start from a value of ~0.5 kg/s for the first BU up to 0.8 kg/s for the fifth BU, then again down to 0.45 kg/s (reached in the BUs #18-20). Simultaneously, the mass flow rate in the second equivalent pipe bundle (EPPs 8–11) monotonically increases from about 0.45 kg/s reaching the same mass flow value of EPP 1–7 in the middle of the manifold mock-up up to a maximum value of ~0.85 kg/s in the last EPP pipe (BU 26). The mean error in the mass flow rate repartition in the BUs, if compared with the results of the full-size manifold, is 4.4%. A local peak error, equal to 14%, is found in the correspondence of the last BU pipe (EPP 8–11) of the outlet manifold, this discrepancy is due to the large scattering of the computed results in the full-scale geometry (see “EPP 8–11 full size” trend in Figure 10). The pressure drop across the entire mock-up has been calculated to be 1.2×10^5 Pa.

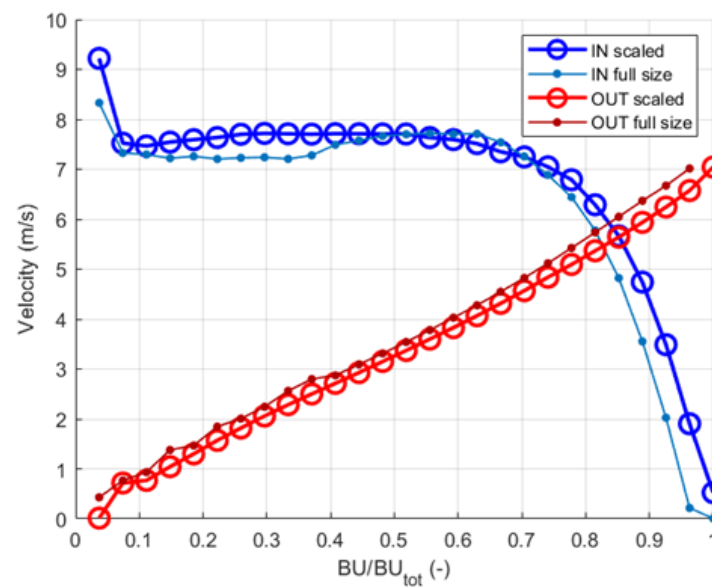

Figure 9. Water velocity computed along the IM (blue symbols and curves) and OM (red symbols and curves) in the full-size (solid symbols) and scaled manifold (open symbols) simulations.

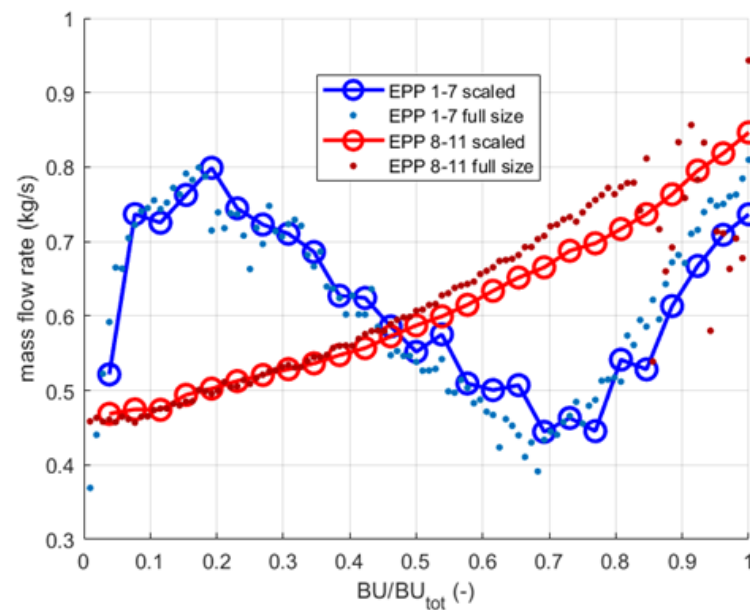

Figure 10. Mass flow rate repartition in the BUs computed along the manifolds for the full-size (solid symbols) and scaled manifold (open symbols). In blue the BU mass flow from the IM to the REC, and in red the mass flow from the REC to the OM.

4.3. Preliminary Instrumentation Layout

Following the design activity of the mock-up, a general Pipe and Instrumentation diagram (P&Id) scheme of the instrumentation was developed (Figure 11). The mock-up dimensions and the number of pipes (about 52) set a challenging task for the definition of the optimal number of signals to acquire and record.

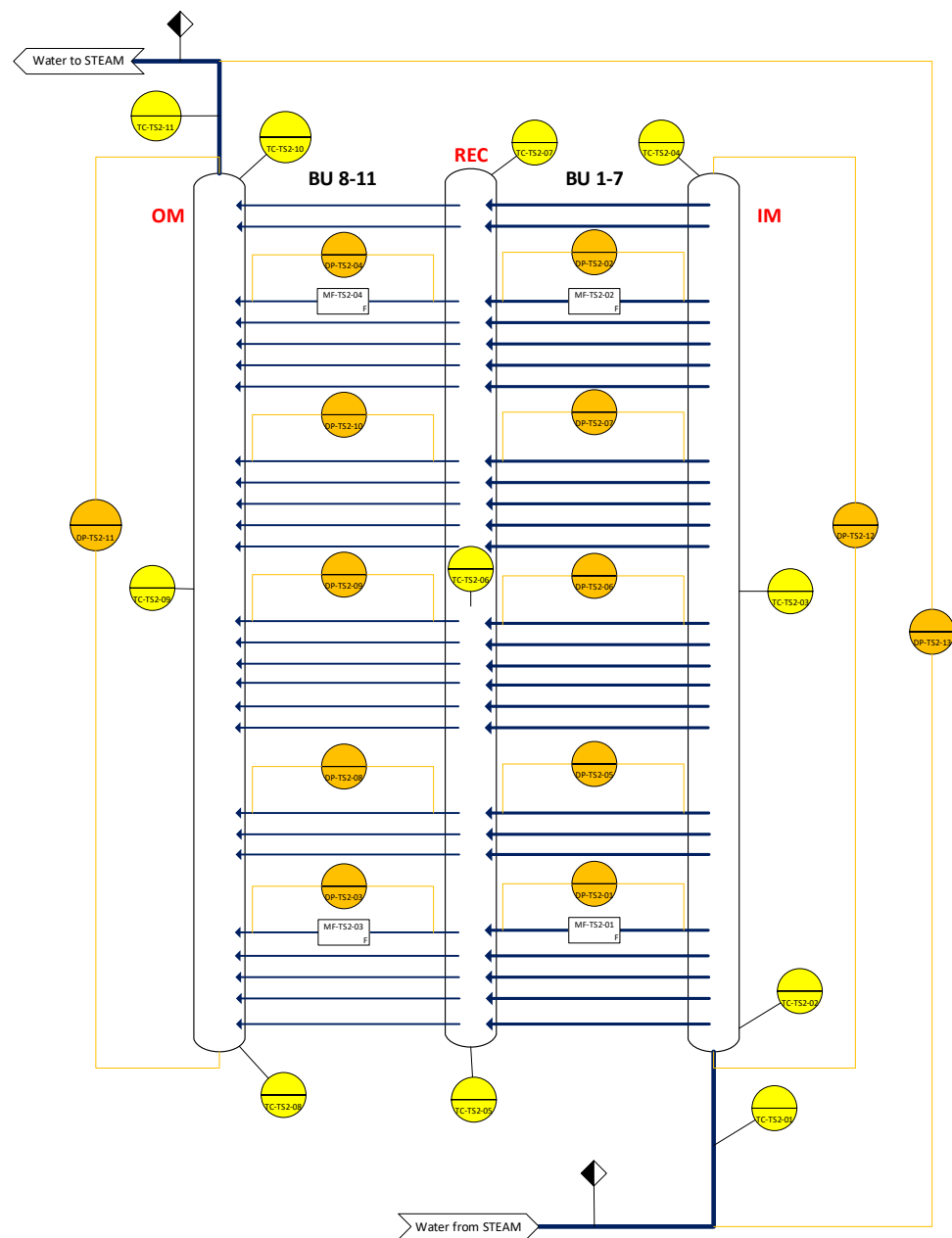

Figure 11. Preliminary P&Id of the manifold MU. Differential pressure transducers (DP) in orange, thermocouples (TCs) in yellow, and mass flow meters (MF) as white boxes.

First, 11 ThermoCouples (TCs), in yellow, will be located along the mock-up to monitor heat losses along the test section: two TCs across the MU, three TCs equally spaced along the IM, three TCs along the recirculation manifold and three TCs along the OM.

As far as the fluid pressure is concerned, three Differential Pressure transducers (DP) will be installed: one DP will be installed across the entire MU and two DPs will be installed on the IM and OM respectively, to measure the pressure trend along their lengths.

Regarding the mass flow measurements, 10 DP meters and 4 mass flow meters will be installed across the BUs of the manifold MU as described above.

Knowing that Equivalent Porous Pipe EPP 1–7 (EPP 8–11) pipes are identical, it is possible to characterize the concentrated pressure loss (K_{loss}) of a single pipe thanks to a mass flow meter and a DP meter mounted on it. In this way, measuring the pressure drop on another identical pipe it is possible to trace the mass flow in the tube. Instrumenting five BU pipes (specially selected) with DP meters it is possible to experimentally draw the mass

flow trend in EPP 1–7 (EPP 8–11) as in Figure 10. To allow experimental redundancy, four pipes (two for each EPP rank) will be instrumented with a mass flow meter and a DP meter.

Moreover, due to the peculiar mass flow trend of EPP 1–7, the mass flow meters installed on this pipe rank will be a non-intrusive clamp on the instrument the location of which can be switched during the experimental campaign to measure different pipe mass flows.

5. Conclusions

In the framework of the strategy of providing a robust design to the components of the water-cooled lithium lead breeding blanket for the EU-DEMO, the design and test of sub-scale components is envisaged. In particular, the design of the mock-up representing the manifolds, routing the subcooled water to the Breeding Units of an Outer Segment, has been performed to be able to verify the flow distribution computed on the full-size component. Appropriate objectives of the foreseen experimental campaign and requirements of the mock-up for the installation on the experimental facility STEAM were fixed to guide the design and numerical activity.

Different scaling approaches were identified and discussed looking for the optimal compromise between the representativeness and manufacturability of the mock-up. The lumping of the double-wall tubes in the breeding units into equivalent pipes has been performed, to reduce both the computational and manufacturing burden.

The scaling procedure has allowed reaching a design that has been proved by a detailed 3D CFD computation to give satisfying flow repartition. The equivalent pipes have been modeled as porous objects with the same hydraulic characteristic of the DWTs, as already successfully done in the simulations of the full-scale manifold.

The mass flow rate repartition in the BUs, along the scaled mock-up, well reproduces the repartition obtained in the full-size geometry. In particular, the same values of mass flow rates, in the range of $0.4 \div 0.8$ kg/s, has been found with an average relative error well below 10% against the same trend of the full-size component. The expected overall pressure losses of the test section are equal to 1.2×10^5 Pa, lower than the one of the full-size (1.9×10^5 Pa), this mismatch is due to the difference in the Eu number.

Last, but not least, a preliminary pipe and instrumentation diagram was developed to fix and optimize both the type of instrumentation needed and its optimal location inside the MU.

Further numerical analyses, mainly by CFD, are ongoing to fix the optimal orifices dimension for the equivalent pipes to ensure the same pressure drop in nominal conditions of the DWT bundles.

Author Contributions: Conceptualization, R.M. and A.C.; methodology, A.C. and L.S.; software, A.C.; validation, A.C. and R.M.; formal analysis, A.C. and L.S.; investigation, R.M. and A.C.; resources, A.D.N. and L.S.; data curation, A.C.; writing—original draft preparation, R.M., L.S. and A.C.; writing—review and editing, P.A.; visualization, P.A. and A.D.N.; supervision, A.D.N.; project administration, P.A.; funding acquisition, A.D.N. All authors have read and agreed to the published version of the manuscript.

Funding: This work has been carried out within the framework of the EUROfusion Consortium, funded by the European Union via the Euratom Research and Training Programme (Grant Agreement No 101052200—EUROfusion). Views and opinions expressed are however those of the author(s) only and do not necessarily reflect those of the European Union or the European Commission. Neither the European Union nor the European Commission can be held responsible for them.

Data Availability Statement: Data sharing is not applicable to this article.

Acknowledgments: We acknowledge the use of the computational resources provided by hpc@polito, which is a project of Academic Computing within the Department of Control and Computer Engineering at the Politecnico di Torino (<http://hpc.polito.it> (accessed on 6 January 2022)).

Conflicts of Interest: The authors declare no conflict of interest. The funders had no role in the design of the study; in the collection, analyses, or interpretation of data; in the writing of the manuscript, or in the decision to publish the results.

References

1. Donn , A.J.H. The European roadmap towards fusion electricity. *Philos. Trans. R. Soc. A: Math. Phys. Eng. Sci.* **2019**, *377*, 20170432. [[CrossRef](#)] [[PubMed](#)]
2. Arena, P.; Del Nevo, A.; Moro, F.; Noce, S.; Mozzillo, R.; Imbriani, V.; Giannetti, F.; Edemetti, F.; Froio, A.; Savoldi, L.; et al. The DEMO Water-Cooled Lead–Lithium Breeding Blanket: Design Status at the End of the Pre-Conceptual Design Phase. *Appl. Sci.* **2021**, *11*, 11592. [[CrossRef](#)]
3. Barucca, L.; Hering, W.; Martin, S.P.; Bubelis, E.; Del Nevo, A.; Di Prinzio, M.; Caramello, M.; D'Alessandro, A.; Tarallo, A.; Vallone, E.; et al. Maturation of critical technologies for the DEMO balance of plant systems. *Fusion Engineering Des.* **2022**, *179*, 113096. [[CrossRef](#)]
4. Eboli, M.; Lorusso, P.; Tarallo, A.; Cammi, A.; Giannetti, F. Design of the new built STEAM facility for low power testing, *EUROfusion Deliverable*, IDM Ref.: EFDA_D_2PSFVX, Aug 2022. Available online: <https://idm.euro-fusion.org/default.aspx?uid=2PSFVX> (accessed on 12 January 2022).
5. Arena, P.; Burlon, R.; Caruso, G.; Catanzaro, I.; Di Gironimo, G.; Di Maio, P.A.; Di Piazza, I.; Eboli, M.; Edemetti, F.; Forgiione, N.; et al. WCLL BB design and Integration studies 2019 activities, *EUROfusion Deliverable*, IDM Ref.: EFDA_D_2P5NE5, Feb 2020. Available online: <https://idm.euro-fusion.org/default.aspx?uid=2P5NE5> (accessed on 10 January 2022).
6. Allio, A.; Savoldi, L.; Arena, P.; Del Nevo, A. Hybrid modelling for the manifolds and coolant flow distribution in the Water-Cooled Lead-Lithium Breeding Blanket of the EU-DEMO reactor. In Proceedings of the 19th International Topical Meeting on Nuclear Reactor Thermal Hydraulics (NURETH-19), Bruxelles, Belgium, 6–11 March 2022.
7. Umminger, K.; Dennhardt, L.; Schollenberger, S.; Schoen, B. Integral Test Facility PKL: Experimental PWR accident Investigation. *Sci. Technol. Nucl. Install.* **2012**, *2012*, 1687–6075. [[CrossRef](#)]
8. Martinez, Q.V.; Reventos, F.; Pretel, C. *Post-Test Calculation of the ROSA/LSTF Test 3-2 Using RELAP5/Mod3.3*, NUREG/IA-0410; USNRC: Rockville, MD, USA, 2012. [[CrossRef](#)]
9. Bestion, D.; D'Auria, F.; Lien, P.; Nakamura, H. *A State-of-the-Art Report on Scaling in System Thermal-Hydraulic Applications to Nuclear Reactor Safety and Design*; Nuclear Safety; OECD Publishing: Paris, France, 2017.
10. Bertinetti, A.; Froio, A.; Ghidersa, B.E.; Gonzalez, F.A.H.; Savoldi, L.; Zanino, R. Hydraulic modeling of a segment of the EU DEMO HCPB breeding blanket back supporting structure. *Fusion Eng. Des.* **2018**, *136*, 1186–1190. [[CrossRef](#)]
11. Froio, A.; Casella, F.; Cismondi, F.; Del Nevo, A.; Savoldi, L.; Zanino, R. Dynamic thermal-hydraulic modelling of the EU DEMO WCLL breeding blanket cooling loops. *Fusion Eng. Des.* **2017**, *124*, 887–891. [[CrossRef](#)]
12. Siddiqui, O.K.; Al-Zahrani, M.; Al-Sarkhi, A.; Zubair, S.M. Flow Distribution in U- and Z-Type Manifolds: Experimental and Numerical Investigation. *Arab. J. Sci. Eng.* **2020**, *45*, 6005–6020. [[CrossRef](#)]
13. Hassan, J.M.; Mohamed, T.A.; Mohammed, W.S.; Alawee, W.H. Modeling the Uniformity of Manifold with Various Configurations. *J. Fluids* **2014**, *2014*, 1–8. [[CrossRef](#)]
14. Siemens PLM Software Inc. *Star-CCM+ User's Guide v. 15.02*; Siemens PLM Software Inc: Plano, TX, USA, 2020.
15. Menter, F.R. Zonal two equation κ - ω turbulence models for aerodynamic flows. In Proceedings of the 23rd Fluid Dynamics, Plasmadynamics, and Lasers Conference, Orlando, FL, USA, 6–9 July 1993. [[CrossRef](#)]

Disclaimer/Publisher's Note: The statements, opinions and data contained in all publications are solely those of the individual author(s) and contributor(s) and not of MDPI and/or the editor(s). MDPI and/or the editor(s) disclaim responsibility for any injury to people or property resulting from any ideas, methods, instructions or products referred to in the content.