

Load bearing hempcrete? A preliminary research

Original

Load bearing hempcrete? A preliminary research / Bohn, Arthur; Mazelli, Redina; Bocco, Andrea. - ELETTRONICO. - (2022). (18th International Conference on Non-conventional Materials and Technologies (NOCMAT 2022)7-23 June 2022) [10.5281/zenodo.6631769].

Availability:

This version is available at: 11583/2977607 since: 2023-03-30T10:17:11Z

Publisher:

Zenodo

Published

DOI:10.5281/zenodo.6631769

Terms of use:

This article is made available under terms and conditions as specified in the corresponding bibliographic description in the repository

Publisher copyright

(Article begins on next page)



LOAD BEARING HEMPCRETE? A PRELIMINARY RESEARCH

Arthur Bohn, DIST Politecnico di Torino, Italy, arthur.bohn@polito.it
Redina Mazelli, DIST Politecnico di Torino, Italy, redina.mazelli@polito.it
Andrea Bocco, DIST Politecnico di Torino, Italy, andrea.bocco@polito.it

ABSTRACT

Hempcrete is generally used in construction as an infill material for loadbearing frames. Contrary to this tendency, a vaulted prototype of load bearing cast-in hempcrete has been built during a training workshop at Cardiff University in 2009 under the project of architect David Lea. A team of researchers at Politecnico di Torino is working on further developing this experiment aiming the construction of a full-scale loadbearing hempcrete pavilion. The paper reports the first research results, including design and sample testing of hempcrete mixtures, computational simulations and detailed design of the prototype. Despite the radicalness of the solution, our investigation seems to show that the use of hempcrete for structure, envelope and insulation at once has a certain potential, at least for small projects.

KEYWORDS

natural fibre-based materials; hempcrete; low-tech; full scale prototyping; hand-on workshop

INTRODUCTION

The construction sector seems to be undergoing a major paradigm shift towards the use of low-carbon materials, due to the urgent need to reduce greenhouse gas emissions. In a time of unprecedented emergency to reduce emissions, the use of a single low-carbon material as hempcrete to build structure, envelope and insulation at once represents a radical approach worth exploring.

It is generally acknowledged that hempcrete can only be used in combination with a load bearing frame (Bevan & Woolley, 2008; Magwood, 2016; Stanwix & Sparrow, 2014).

Architect David Lea designed a thick-walled vaulted one storey pavilion intended to be built at St Fagans National History Museum in Cardiff (Harper, 2011; D. Lea, personal communication, October 2009). A portion of this structure was successfully built and tested during a training workshop at Cardiff University in 2009. To our knowledge, this was the first time hempcrete was used without a supporting structure.

The paper reports the further development of Lea's idea by a team of researchers at DIST (Politecnico di Torino) aiming the construction and monitoring of a full-scale pavilion, which will allow further investigation on the performance of this innovative use of hempcrete. It resumes and analyses the results of the Cardiff workshop and presents the first results of the project, including mix design and sample testing process. Further, we also argue about vault geometry optimisation.

Background

David Lea has been interested in low energy materials and construction techniques since the ecological movements of the early 1970s. He and Pat Borer designed the most significant buildings of the Centre for Alternative Technology (CAT), most notoriously the Wales Institute of Sustainable Education (WISE) building. His interest in hemp lime stemmed from this project: 2000 m² of the 500 mm thick perimeter walls are infilled with hempcrete cast or blown around a timber load bearing frame (Blundell Jones, 2010; Bocco Guarneri, 2020).

Using a low-carbon material such as hempcrete to build structure, envelope and insulation was consistent with Lea's promotion of, as architectural critic Peter Blundell Jones puts it, "the idea of a modest, efficient and humane architecture" (Voelcker, 2015: 11). The use of a largely prevalent

material for the whole construction enhances the correlation with the form, defined geometrically by the need to use all units in compression. The form of Lea's Hemplime Pavilion is inspired by the mud brick vaults of Hassan Fathy (D. Lea, personal communication, 1 February 2022), in turn a revival of the traditional Nubian vaults (Fathy, 1973). The catenary line closely follows early gothic arches of the Middle Ages in Europe, for instance those at Le Thoronet Abbey (D. Lea, personal communication, October 2009).

THE HEMPLIME VERTICAL STUDIO AT CARDIFF 2009

The Hemplime Studio project of 2009 was part of the Vertical Studio at the Welsh School of Architecture – a teaching initiative for bachelor students engaging in innovative activities run by professionals in the fields of art, technology, design, urbanism and planning. (Vertical Studio, n.d.) The flexibility of this pedagogic approach enriched and diversified the students' skills beyond their university's curriculum; while also providing a certain freedom for practitioners to explore creative ideas. The Hemplime Studio was modestly financed and partially sponsored by local firms. Nine students worked in shifts on research, design and construction. (Harris & Lea, 2010a, 2010b)

Design

The design of the vault came from setting up a suspended chain and superimposing a two-centred arch close to the catenary line falling roughly in the middle third of the vault thickness and hitting the ground just inside the piers. The curve of the inner surface of the vault was corrected to form a regular pointed arch to facilitate the building process, while the upper surface formed a 30° pitched roof. Cardiff University's Estates Division provided a suitable space for the construction at the university premises: large enough for the storage of materials and tools, with good access to water and high enough for the intended height of the vault (2.8 m). The available space limited the dimensions: the vault spanned 3 m and a 1.2 m thick section was built (Fig. 1). It was supported on 0.6 x 1.2 m piers, high 1.8 m to the spring. (Harris & Lea, 2010a, 2010b)

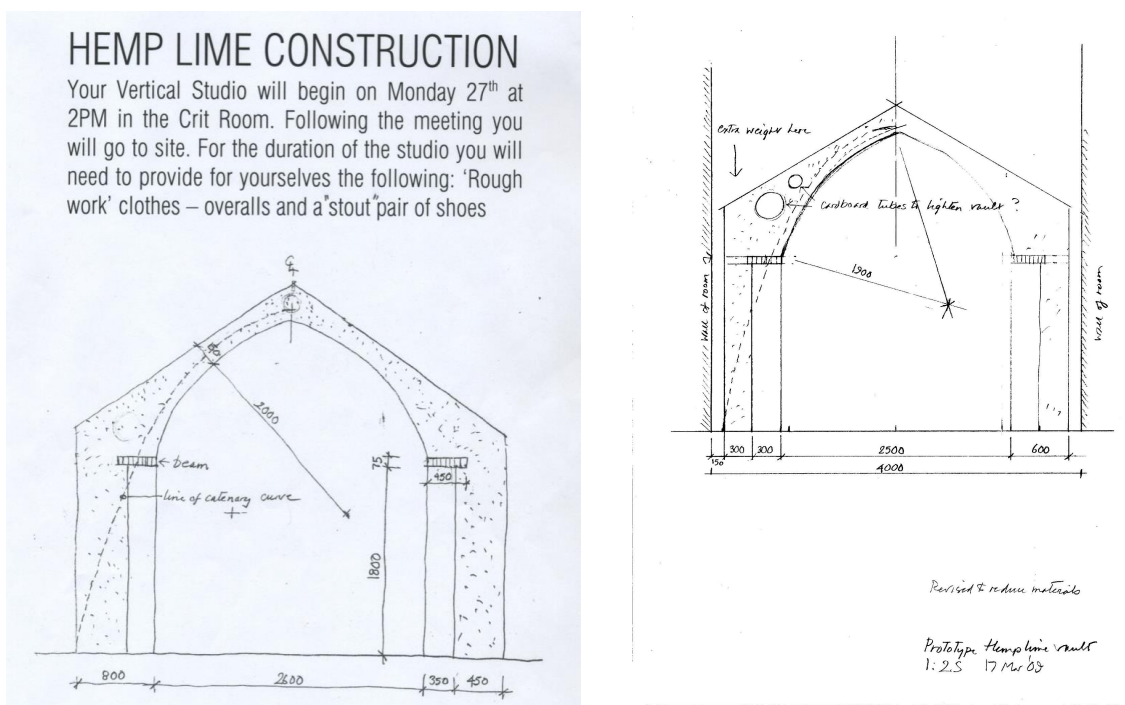

a) Flyer of the Hemp Lime Vertical Studio 2009

b) Adaptation of the project to the available construction space

Figure 1: Hand-drawn sections of the designed vault

Construction

Firstly, the students were trained on construction site management and safety. The hempcrete was provided by Limetec, which in turns used Tradical hempcrete, mixed on site following the company's instructions. It was cast and tamped into simple lightweight ply shuttering in a number of stages, consequently marking different casting levels that were visually evident after the construction. The 0.8 m wide recesses in the piers were spanned by wooden boards (Fig. 2b). The top layer of the roof was tamped into a denser finish, and cedar shingles were fixed directly into the hempcrete using large-diameter screws (Fig. 2c). (Harris & Lea, 2010a, 2010b; D. Lea, personal communication, 1 February 2022)



Figure 2: The hemp lime vault built during the Vertical Studio 2009

Structural testing

The hemp lime vault was tested seven months after the completion under the supervision of Professor Abid Abu-Tair and Dr. John Kinuthia of the University of Glamorgan's Civil Engineering Research Unit. The hempcrete had carbonated and dried out evenly, making it difficult to demolish the structure after testing. Two hangers supported a platform that was loaded up with 25 kg sandbags (Fig. 3). At the 26th sandbag the vault began to spread slightly, and cracks began to show along the timber boards above the recesses, showing that they had actually weakened the resistance to lateral loads. The side displacement, monitored through two digital transducers, started to increase rapidly after a continuous load of 8,5 kN for both loading points. At that instant the loading was discontinued for safety reasons (Fig. 4). The calculated load of the arch was 1.6 kN/m², close to the service load. (Harris & Lea, 2010a, 2010b; Abu-Tair & Kinuthia, 2009) However, the supervisors stated:

It is our professional judgement that the structure would have withstood much more load had we continued the loading further before stability became a serious issue. Furthermore, had the structure of the arch had some form of a simple tie at the bottom of the arch, the structure would have carried three to four times the load applied, which would take it way above the kind of ultimate loads expected to be carried by such structures. The tie would also help with the stability as we did not test the structure under skewed loading. (Abu-Tair & Kinuthia, 2009)



Figure 3: Structural testing of the hemp lime vault

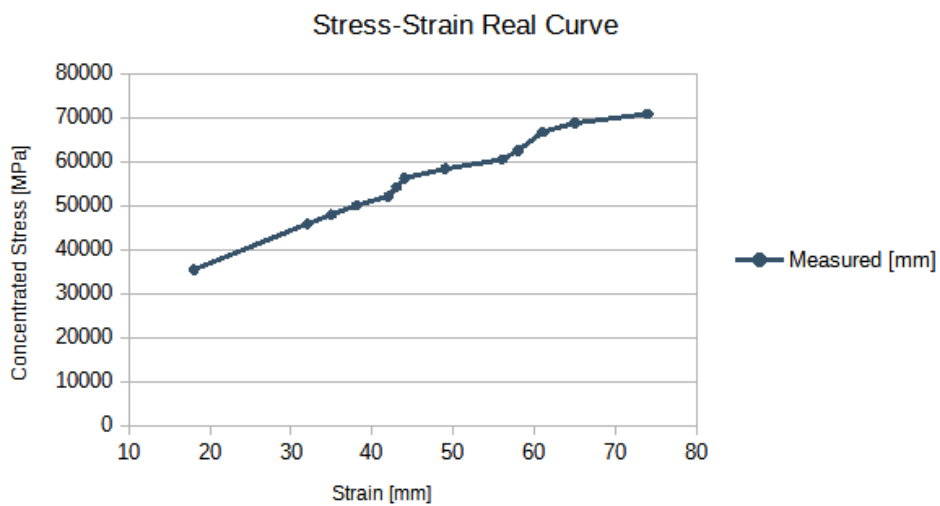

Figure 4: Load displacement behaviour of the vault

IMPROVING RESEARCHES AT POLITECNICO DI TORINO

The aforementioned experience seems to show that hemp lime has the potential to be used as a material for simple monolithic constructions like vaults. Based on this assumption, further research has been developed to assess some design improvements such as material composition mixture, geometry optimisation for saving the amount of materials employed, and other structural compromises to strengthen the full scale prototype.

Methodology

In order to explain the rest of this research, a chart is presented below showing the processes organised according to their relations.

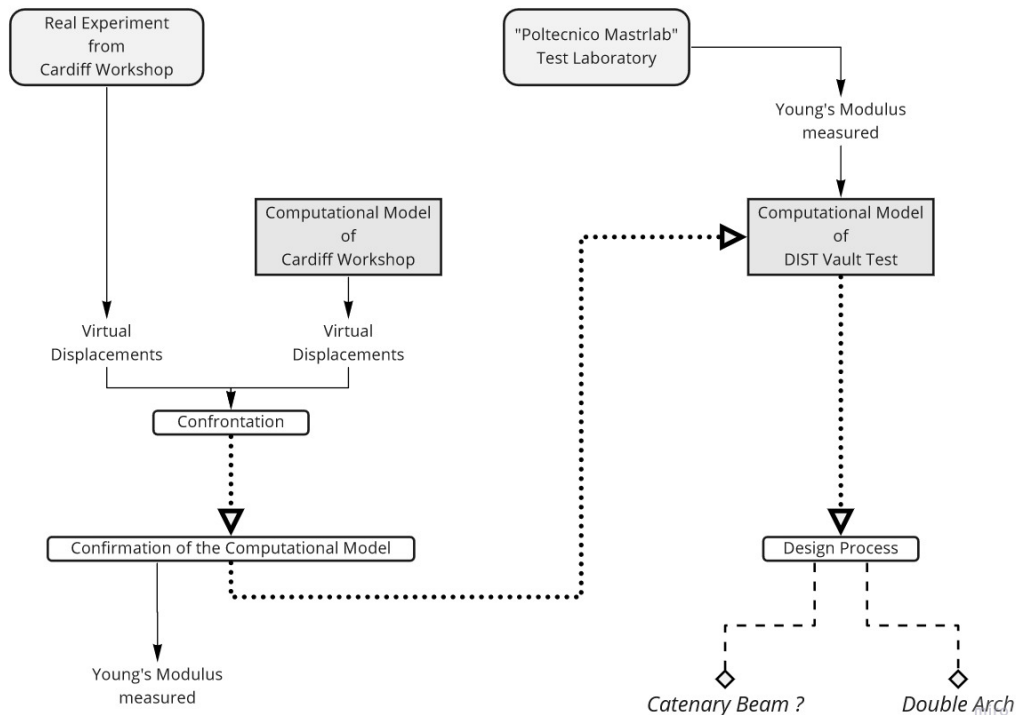

Figure 5: Methodological diagram of the design process

Analysis of the experiment at Cardiff

Computational Modelling

A computational model has been drawn on a linear elastic model software. This choice was made to have a first overview about the issue, allowing us to examine very quickly the hypotheses. The vault has been set up on a CAD software to evaluate the coordinates of discretisation points, subsequently needed to build the structural model. We assumed that the material was isotropic, which we deem is an acceptable approximation, given the random orientation of the shiv inside the lime matrix. We inputted the different sections related to the positions of each ashlar. In order to represent the dead load, and knowing the different measured densities inside the vault, the weight of each virtual ashlar was calculated and then uniformly applied to each of them.

Young's modulus assessment

The creation of a computational model was first meant to interpret the real displacements during the test at Cardiff in 2009. Actually, we decided to switch the analysis, and hence to determine the modulus of elasticity by comparing the real displacements and the computed results. The chart below shows that the mixture's Young's Modulus lies between 5 and 10 MPa (Fig. 6). This clearly explains why load-bearing hemp-lime requires a large amount of material and a static scheme of pure compression. We noticed a large gap between the experimental curve and the computational results. This could be explained by the fact that the ductility of the real material is higher than assumed in the software algorithm. If this was correct, then the vault would seem to have reached its plasticity stress boundary.

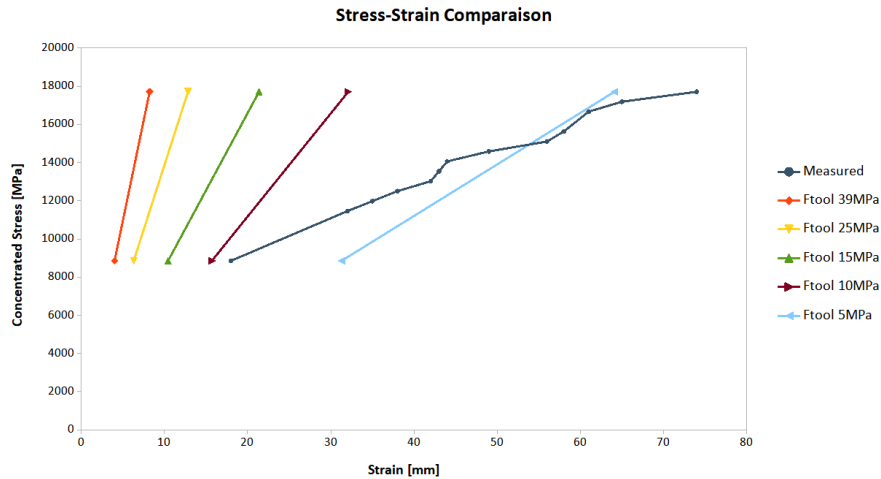

Figure 6: Stress-strain comparison of measured and computational displacements

Material composition

Different types of hemplime mixes were designed to broaden the palette of results. This work involved masters' thesis students and profited from the help of Fausto Cerboni, an artisan who contributed his extensive field experience. We developed different mixtures composed of hemp shiv of various sizes (0~20 mm) and hydraulic lime-based binders. There were two series of mixture designs due to the time it took the specimens to be dry enough for mechanical tests. The specimens were obtained both by means of a manual press and by casting and constipating the material in removable moulds (Fig. 7). All samples were tested for compressive strength using a universal hydraulic servo-controlled compressive testing machine (Zwick Roell ZmartPro) at a cross-head speed of 3 mm/min, based on a thorough literature review (see for instance Amziane et al., 2015; Amziane & Arnaud, 2013; Arnaud & Gourlay, 2012; Collet et al., 2015; Nguyen et al., 2009; Niyigena et al., 2015, 2019; Tronet et al., 2016; Williams et al., 2017).

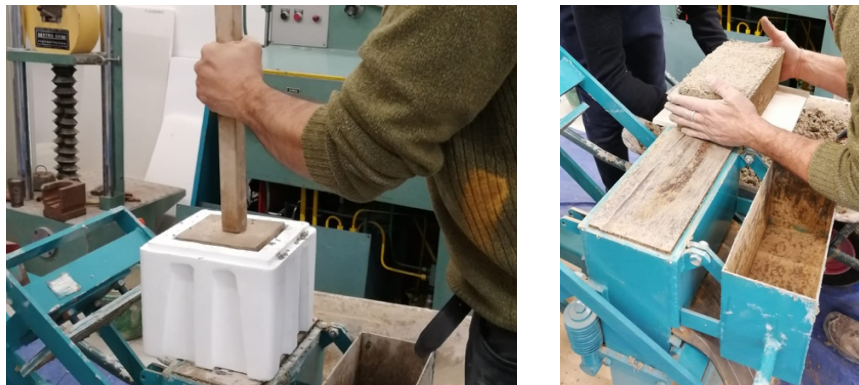

Figure 7: Cubic samples obtained by casting and constipating the material in removable moulds and brick samples obtained by means of a manual press

The first series allowed to establish an optimised particle size distribution of the hemp shiv. In this regard, the granularity of each product was accurately analysed through a vibrating screen sieve machine. Subsequently, different compositions of hemp shiv were established for each specimen based on determined ratios derived from a pre-established Fuller-Bolomey theoretical curve. As for the binder, we decided to use natural hydraulic lime (NHL) combined with some pozzolan (Sheridan et al., 2017), which should react with the remaining 'free' lime. In fact, the volume percentage of the added pozzolan coincides with the 'free' lime content indicated by the NHL manufacturer. However,

this resulted in insufficient compressive strength, as it did not exceed 0.25 MPa (Fig. 8, mixture 1.2). This urged us to envisage a stronger binder composition.

The second series of specimens had the same aggregate particle size distribution (PSD) as the mixture 1.2. By adding natural Roman cement to the binder, we obtained a higher strength; its increase in proportion (Fig. 9) reflected in a significant increase in compressive strength: see the three blue bars in the chart below (Fig. 8).

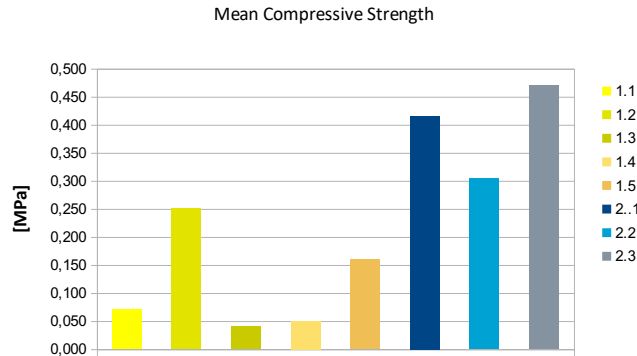

Figure 8: Compressive strengths of all mixtures [kN]

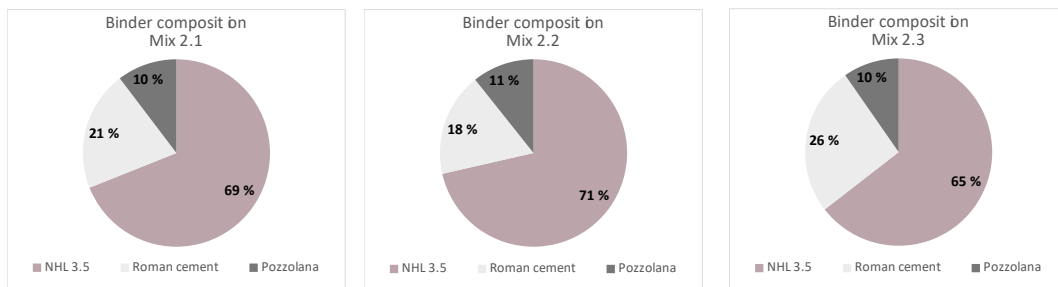

Figure 9: Composition of the binders for the second set of specimens [vol%]

The modulus of elasticity was graphically quantified for the second set of specimens (Fig. 10). The charts show that for the first two mixtures, the breakpoint has been reached. Instead, the third one, which contained more Roman cement, did not show rapid failure. The modulus increases in relation to the amount of Roman cement; it is shown at a curing time of 65 days.

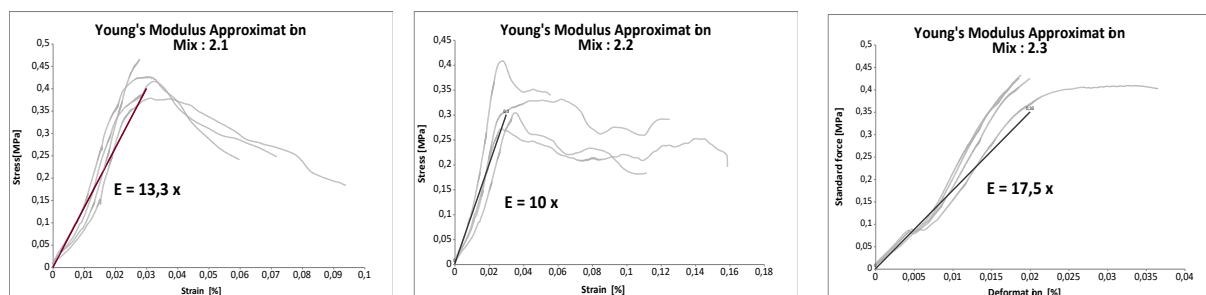

Figure 10: Stress-strain curves _ Measure of Young's Modulus (E) with a graphical method

The second set of mixtures was studied mainly through 12x15x30 cm brick samples, manually pressed. In addition to these samples, 15-cm cubes were prepared in order to double-check the results. These were quite surprising, as the mechanical reaction of the cubic samples didn't show the same behaviour as the bricks. The stress-strain curves of cubes revealed a stronger and more ductile response (Fig. 11). One of the possible reasons is that bricks were loaded parallel to the y axis (Fig. 12), so the risk of effusion was higher than for the cube samples.

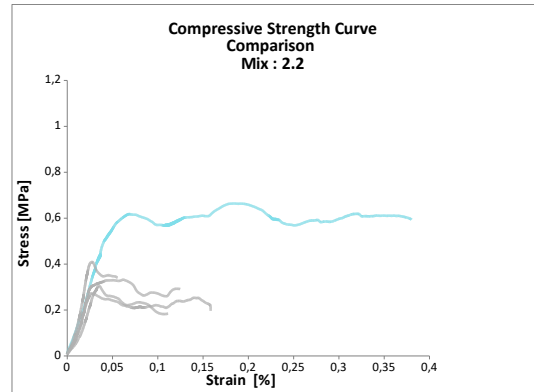
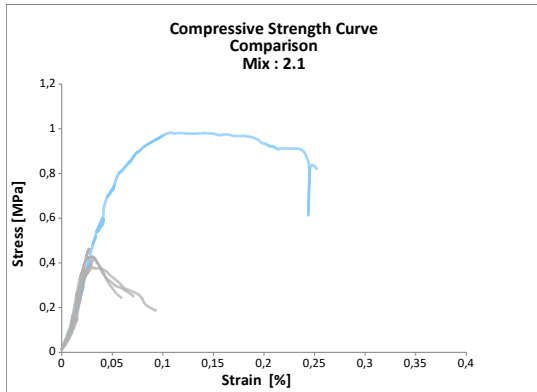

Figure 11: Comparisons of stress-strain curves: brick samples (grey) vs cube samples (blue)



Figure 12: Compression tests of brick and cube samples

It should be noted that the main aim of composing our own mixtures and performing the structural tests, was not to reach a mechanical response close to that of conventional load-bearing materials; but rather to maximise the control over the components of the hempcrete mixture and its subsequent characteristics, as opposed to a pre-mixed proprietary binder.

Vault geometry design

Our project aims to provide information on a broad range of issues related to sustainable construction, including constructability, energy saving for heating/cooling, embodied environmental impacts of the construction phase of the life cycle (A1-A5). Three pavilions – each with a floor area of about 35 m² – will be built to present different sustainable techniques to students and the general public. The load-bearing hemp lime arch prototype acts as a test bed that will allow to build the pavilion proper.

In order to validate the geometry, we performed a graphic design process by discretising the arch in virtual voussoirs, given that hempcrete is a homogeneous material.

This line of thrust represents the resulting forces that occur inside these virtual bricks. In order to make the structure work in pure compression, it is important to contain this curve within the central third of the vault. The ogive arch shows a slight weakness at the top but increasing the weight at that point corrects the risk of outward collapse.

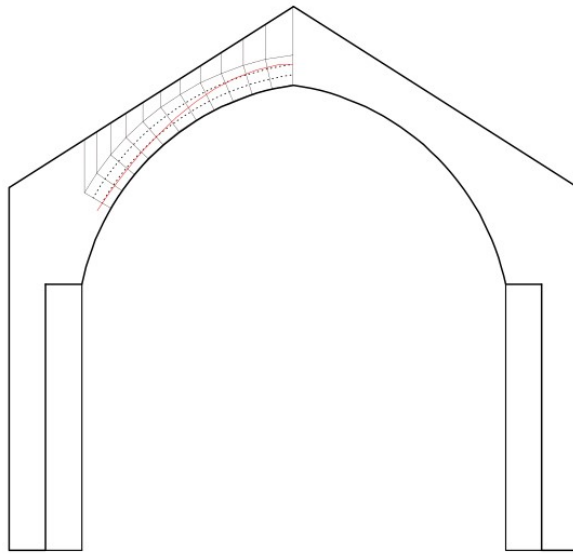

Figure 13: Line of thrust of the critical portion of the vault

The dimensional characteristics were changed by increasing the span and scaling the arch accordingly. The form of the ogival vault has been maintained. For this experiment, the span is 3.5 m and the internal maximum height is 3.85 m (Fig. 13).

As a development of the experimentation of 2009, the vault has been designed with barrel arches at its piers. The reason is to use a single material and avoid cracks along the discontinuity created by the timber lintels (Abu-Tair & Kinuthia, 2009; D. Lea, personal communication, 1 February 2022).

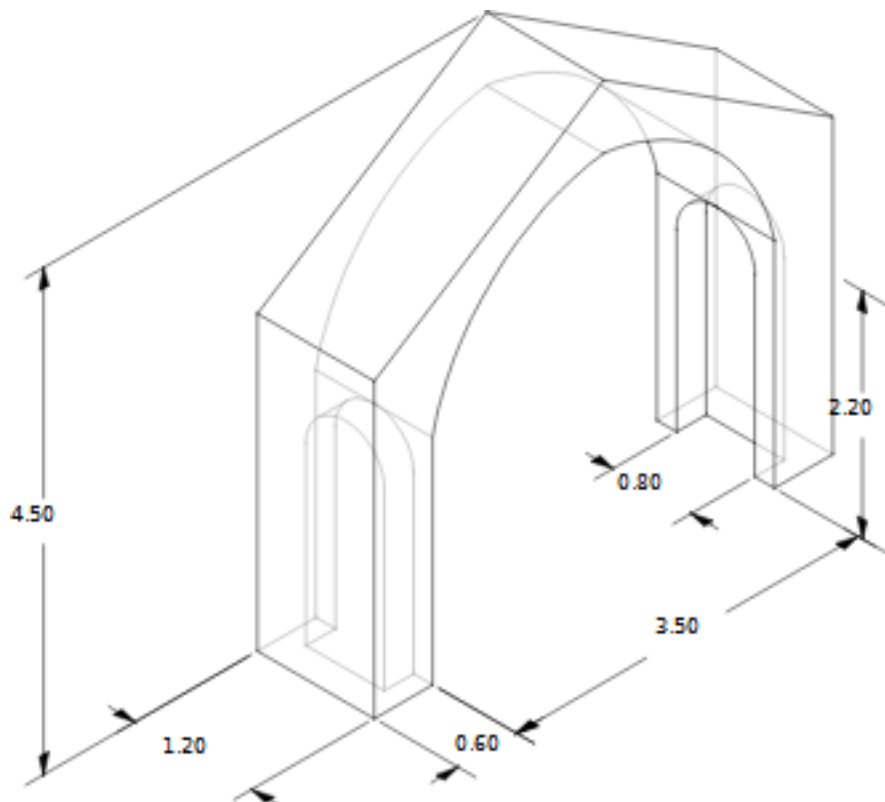

Figure 13: Dimensions of the prototype (axonometric view)

Structural scheme improvement

The hypothesis on which we worked for improving the vault's mechanical response is the introduction of a horizontal tie at the bottom of the arch. Even if this implies the use of another material (timber, instead of a monolithic hemp-lime construction), it would represent an efficient compromise. The tie is high enough to let people across. It has to resist a tension load of 6 kN. From the computational simulations (Fig. 15 and 16) it can be noticed that the compression of the virtual ashlars is perfectly respected and brings the whole weight vertically to the ground. Deformations of the vault (Fig. 17) are of the order of millimetres (9 mm at the apex, and 7 mm at the base of the arch), therefore we can conclude that the simulations confirm the aforementioned hypothesis.

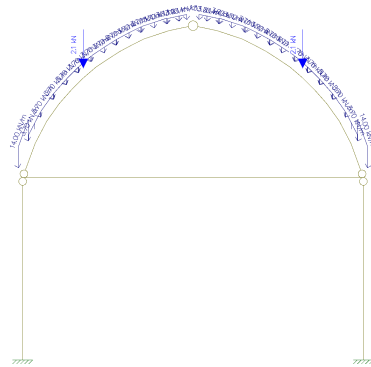

Figure 15: Schematic representation of the load distribution

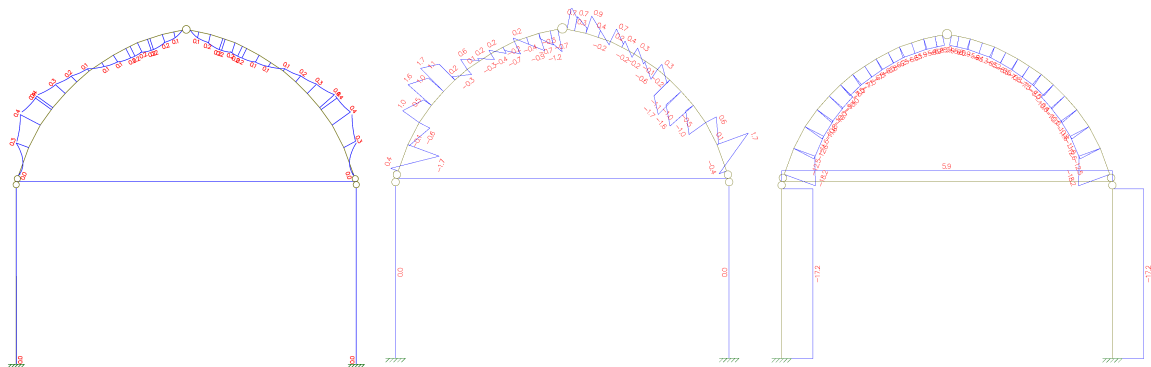

Figure 16: Bending moment (M) [kN.m], shear force (V) [kN], axial force (N) [kN] diagrams

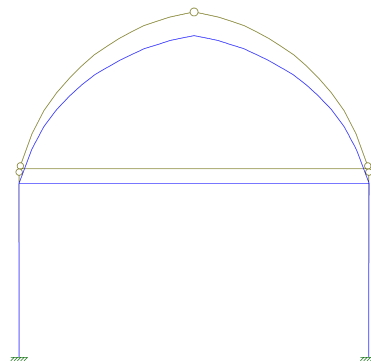

Figure 17: Schematic representation of the deformation of the vault

Constructability

Being an illustrative project of sustainable contemporary architecture, we chose to consider two different hemp-lime building techniques: brick masonry construction, and cast on site. Hemp lime

bricks have the advantage of easy handling, which is quite important at an educational building site. They would be produced at one of the Politecnico's laboratories and would be transported to the building site after the binder has cured.

The other method is the same as at Cardiff. Casting allows to mix on site and pour immediately afterwards. The construction of the formwork would pose technical challenges and would imply using timber not easily reusable in other projects. Another challenge of this technique is the correct, thorough drying of the cast material.

These reasons led us to consider both options and to exploit their different advantages. Bricks will compose the arch skeleton like in Hassan Fathy's architecture, while cast hemp lime will be used to build the piers.

DISCUSSION

The Cardiff experiment is an exemplary case that explores a very simple design principle: the material defines geometrically the space. Of course, this presents a number of challenges: the lack of tensile elements a priori excludes conventional ideas such as cantilevers, corner openings, free plans and separation of structure and envelope (Harris & Lea, 2010a). However, it does not affect creativity; conversely, it allows for conscious sensitivity to the essential nature of the materials. Tim Coleridge, architect and lecturer at CAT, wrote on *The Architectural Review*:

This (the experimental hempcrete vault at Cardiff) indicated a fresh architectural expression that directly challenges the high-tech minimal 'eco-technical' logic [...], a new tectonic, that works with the inherent qualities of the material rather than squeezing it to fit a predetermined form. (Coleridge, 2014)

The tendency to fit natural materials into predictable and uniform performance standards of the industrial paradigm has often led to their misuse and consequent prejudices and, at the very least, to a lack of deep understanding of their potential. In fact, Lea suspected that hempcrete had not been used structurally before as "it is slightly compressible and so impossible to calculate because the compressibility is determined by the mix, which will almost certainly vary a little" (D. Lea, personal communication, 2 November 2014). While this difficulty should be recognised – together with the constraints of building codes – it can be faced with creative problem-solving skills. Moreover, structures built with a single prevalent material or mixture and working under pure compression are not new: there are many examples such as the earth brick architecture of the Middle East and the archaic forms of the medieval vaulted cathedrals in Europe, to mention a few. Conventional construction tends to incorporate rigid structural materials like timber, steel or pre-stressed concrete, reducing the quantity of materials and (possibly) the financial costs. Peter Harper believes that if there are positive benefits associated with the use of some materials, especially those derived by biomass, this design principle might be weakened or even reversed (Harper, 2011). In the case of hempcrete, these benefits are to be found in its low embodied energy and carbon emissions. Several studies have shown that the total carbon footprint of hempcrete mixtures results lower than the CO₂ uptake due to the biogenic carbon captured and stored during hemp growth (Ahmed et al., 2022; Arehart et al., 2020; Scrucca et al., 2020). Moreover, hemp is an annual crop, which is clearly advantageous to, for instance, construction timber. Further investigation is needed in this regard – e.g., the composition of the binders to lower their overall emissions; the comparison of impacts between a loadbearing hempcrete construction and a conventional timber framed one; etc.

CONCLUSION

Investigating the possibility of using loadbearing hempcrete for low-rise buildings is a challenge worth undertaking. The first results of the research are promising and show that the use of a smaller array of materials and components enhances the correlation material-structure-form and enables a simple and creative way of building, challenging contemporary prejudices and arising sensitivity to the essential nature of the materials.

The next step of the research will be the construction and monitoring of a full-scale load bearing hempcrete pavilion, which will allow further investigation on the performance and environmental impacts of this innovative use of hempcrete.

REFERENCES

- Abu-Tair, A. & Kinuthia, J. (2009). Structural testing of hempcrete vault type structure. [Structural report]. Copy in possession of the authors.
- Ahmed, A. T. M. F., Islam, M. Z., Mahmud, M. S., Sarker, M. E., & Islam, M. R. (2022). Hemp as a potential raw material toward a sustainable world: A review. *Heliyon*, 8(1), e08753. <https://doi.org/10.1016/j.heliyon.2022.e08753>
- Amziane, S., & Arnaud, L. (2013). *Bio-aggregate-based Building Materials: Applications to Hemp Concretes*. Wiley. <https://www.wiley.com/en-us/Bio+aggregate+based+Building+Materials%3A+Applications+to+Hemp+Concretes-p-9781848214040>
- Amziane, S., Nozahic, V., & Sonebi, M. (2015). Design of mechanically enhanced concrete using hemp shiv. *Academic Journal of Civil Engineering*, 33(2), 422–426. <https://doi.org/10.26168/icbbm2015.65>
- Arehart, J. H., Nelson, W. S., & Srubar, W. V. (2020). On the theoretical carbon storage and carbon sequestration potential of hempcrete. *Journal of Cleaner Production*, 266, 121846. <https://doi.org/10.1016/j.jclepro.2020.121846>
- Arnaud, L., & Gourlay, E. (2012). Experimental study of parameters influencing mechanical properties of hemp concretes. *Construction and Building Materials*, 28(1), 50–56. <https://doi.org/10.1016/j.conbuildmat.2011.07.052>
- Bevan, R., & Woolley, T. (2008). *Hemp Lime Construction: A Guide to Building with Hemp Lime Composites*. IHS BRE Press.
- Blundell Jones, P. (2010, December 21). Wales Institute for Sustainable Education by David Lea and Pat Borer, Machynlleth, Wales, UK. *Architectural Review*. <https://www.architectural-review.com/today/wales-institute-for-sustainable-education-by-david-lea-and-pat-borer-machynlleth-wales-uk>
- Bocco Guarneri, A. (2020). *Vegetarian Architecture: Case Studies on Building and Nature*. Jovis Verlag GmbH.
- Coleridge, T. (2014, October 22). Pandering to bamboo: On skyscrapers made out of wood. *Architectural Review*. <https://www.architectural-review.com/buildings/bamboo/pandering-to-bamboo-on-skyscrapers-made-out-of-wood>
- Collet, F., Pretot, S., Mazhoud, B., Bessette, L., & Lanos, C. (2015). Comparing hemp composites made with mineral or organic binder on thermal, hygric and mechanical point of view. *Academic Journal of Civil Engineering*, 33(2), 228–234. <https://doi.org/10.26168/icbbm2015.35>
- Fathy, H. (1973). *Architecture for the Poor: An Experiment in Rural Egypt*. University of Chicago Press.
- Harper, P. (2011). Building Materials Derived from Biomass. *Peter Harper*. <http://peterharper.org/s/BUILDING-MATERIALS-DERIVED-FROM-MISCANTHUS.DOCX>
- Harris, S., & Lea, D. (2010a). The Hemplime Vault. In *Educating architects towards innovative architecture* (pp. 245–253). EAAE.
- Harris, S., & Lea, D. (2010b). The Hemplime Vault. *Materials Architecture Design Environment*, 6, 89–90.
- Magwood, C. (2016). *Essential Hempcrete Construction: The Complete Step-by-Step Guide*. New Society Publishers.

- Nguyen, T.-T., Picandet, V., Amziane, S., & Baley, C. (2009). Influence of compactness and hemp hurd characteristics on the mechanical properties of lime and hemp concrete. *Revue Européenne de Génie Civil*, 13, 1039–1050. <https://doi.org/10.3166/regc.13.1039-1050>
- Niyigena, C., Amziane, S., & Chateaneuf, A. (2019). Assessing variability of hemp concrete properties during experimental tests: A focus to specimens' number. *Academic Journal of Civil Engineering*, 37(2), 270–278. <https://doi.org/10.26168/icbbm2019.39>
- Niyigena, C., Amziane, S., Chateaneuf, A., Arnaud, L., Bessette, L., Collet, F., Escadeillas, G., Lanos, C., Lawrence, M., Magniont, C., Marceau, S., Pavia, S., Peter, U., Picandet, V., Sonebi, M., & Walker, P. (2015). RRT3: Statistical analysis of hemp concrete mechanical properties variability. *Academic Journal of Civil Engineering*, 33(2), 334–340. <https://doi.org/10.26168/icbbm2015.51>
- Scrucca, F., Ingrao, C., Maalouf, C., Moussa, T., Polidori, G., Messineo, A., Arcidiacono, C., & Asdrubali, F. (2020). Energy and carbon footprint assessment of production of hemp hurds for application in buildings. *Environmental Impact Assessment Review*, 84, 106417. <https://doi.org/10.1016/j.eiar.2020.106417>
- Sheridan, J., Sonebi, M., Taylor, S., & Amziane, S. (2017). Effect of linseed oil and metakaolin on the mechanical, thermal and transport properties of hemp-lime concrete. In S. Amziane & M. Sonebi (Eds.), *ICBBM 2017, 2nd International Conference On Bio-Based Building Materials* (Vol. 119, pp. 125–133). RILEM. https://www.rilem.net/publication/publication/523?id_papier=12496
- Stanwix, W., & Sparrow, A. (2014). *The Hempcrete Book: Designing and Building with Hemp-lime*. Green Books.
- Tronet, P., Lecompte, T., Picandet, V., & Baley, C. (2016). Study of lime hemp concrete (LHC) – mix design, casting Process and mechanical behaviour. *Cement and Concrete Composites*, 67. <https://doi.org/10.1016/j.cemconcomp.2015.12.004>
- Vertical Studio*. (n.d.). Cardiff University. Retrieved 25 March 2022, from <https://www.cardiff.ac.uk/architecture/courses/undergraduate/undergraduate-portfolio/bsc-architectural-studies-portfolio/vertical-studio>
- Voelcker, A. (2015). *David Lea: An Architect of Principle*. Artifice Books on Architecture.
- Williams, J., Lawrence, M., & Walker, P. (2017). Projection formed and precast hemp-lime: Better by design? *Academic Journal of Civil Engineering*, 35(2), 252–259. <https://doi.org/10.26168/icbbm2017.38>

ACKNOWLEDGEMENTS

The work presented in this paper was fully supported by DIST in the framework of the initiative DIST Dipartimento di Eccellenza 2018–2022, funded by MUR (Italian National Ministry of University and Research).

Data about the Hemplime Vertical Studio (Cardiff, 2009) was kindly provided by David Lea and Sylvia Harris.

The hempcrete mixtures were prototyped at LaSTIn (Department of Architecture and Design, Politecnico di Torino), under the tutoring of Fausto Cerboni (Terrapaglia s.r.l.). MSc students Gustavo Ferreira Zapponi and Elena Tenca participated in the mix design, prototyping and monitoring, as part of their masters' thesis.

The samples were tested at MastrLAB (Department of Structural, Geotechnical, and Building Engineering, Politecnico di Torino).

The test pavilions will be erected in Grugliasco at a site generously offered by the local municipality through Le Serre company.

We would like to acknowledge our gratitude and admiration for our friend and colleague David Lea who sadly passed away on the 8th of April 2022, while we were trying to put in practice his advice in the research on this material.

CONFLICT OF INTEREST

The authors declare that they have no conflicts of interest associated with the work presented in this paper.

DATA AVAILABILITY

Data on which this paper is based is available from the authors upon reasonable request.