

Disaggregated SCI Estimation for QoT-E in Mixed Fibers Network Segments

Original

Disaggregated SCI Estimation for QoT-E in Mixed Fibers Network Segments / Virgillito, Emanuele; Castoldi, Andrea; D'Amico, Andrea; Straullu, Stefano; Bratovich, Rudi; Rodriguez, Fransisco M.; Bovio, Andrea; Pastorelli, Rosanna; Curri, Vittorio. - ELETTRONICO. - (2023). (Optical Fiber Communication Conference 2023 San Diego, California, United States 5–9 March 2023) [10.1364/OFC.2023.Th2A.29].

Availability:

This version is available at: 11583/2976131 since: 2023-02-17T14:12:39Z

Publisher:

Optica Publ. Group

Published

DOI:10.1364/OFC.2023.Th2A.29

Terms of use:

This article is made available under terms and conditions as specified in the corresponding bibliographic description in the repository

Publisher copyright

Optica Publishing Group (formely OSA) postprint/Author's Accepted Manuscript

“© 2023 Optica Publishing Group. One print or electronic copy may be made for personal use only. Systematic reproduction and distribution, duplication of any material in this paper for a fee or for commercial purposes, or modifications of the content of this paper are prohibited.”

(Article begins on next page)

Disaggregated SCI Estimation for QoT-E in Mixed Fibers Network Segments

E. Virgillito^{1,*}, A. Castoldi^{2,**}, A. D'Amico¹, S. Straullu^{3***}, R. Bratovich², F. M. Rodriguez², A. Bovio², R. Pastorelli² and V. Curri¹

¹Politecnico di Torino, DET, Corso Duca degli Abruzzi, 24, 10129, Torino, Italy - *emanuele.virgillito@polito.it

²SM-Optics, Via John Fitzgerald Kennedy, 2, 20871, Vimercate, Italy - **andrea.castoldi@sm-optics.com

³LINKS Foundation, Via Pier Carlo Boggio, 61, 10138, Torino, Italy - ***stefano.straullu@linksfoundation.com

Abstract: We propose a spatially disaggregated model for self-channel noise coherent buildup in mixed fibers lines including dispersion compensated spans. We show that properly modeling coherence is crucial for accurate GSNR estimation. © 2023 The Author(s)

1. Introduction

Dual-Polarization coherent transmission dominates the backbone network market segment with optical line systems (OLS)s made up of dispersion uncompensated fibers spans. The access and metro segment instead still largely employs legacy intensity modulated-direct detected (IMDD) transceivers at 10 Gbps, thus using inline dispersion compensating units (DCU). The recent technological advancements on the coherent transceivers have made available open optics pluggables able to deliver 400 Gbps with a small footprint using 64 GBaud on the 75 GHz DWDM grid using DP-16QAM for the short each and long haul accordingly to the OpenZR(+) standard [ref:ozr]. Furthermore, optical networking is evolving towards openness and disaggregation, with the aim of providing network features as slicing, virtualization and dynamic reconfiguration accordingly to the traffic request. However, while optical system vendors push towards the upgrade to cutting edge technologies, network operators aim at maximize the return of investment (ROI) of the installed hardware and deployed fiber. In this context, being able to route coherent lightpaths (LP) through dispersion-managed (DM) segments already loaded with 10G traffic may enable cost savings and added flexibility to optical networking. Indeed, while the upgrade of DM segments to fully coherent technology by removing DCUs is certainly foreseen, in some cases it may be still too costly or it may disrupt existing legacy traffic.

Exposing networking function, such as path feasibility, in this scenario thus requires a (semi-)analytical modeling tool to be implemented in a quality-of-transmission estimator (software (QoT-E) software tool to assess the degradation due to non-linear propagation induced by Kerr effect. It is well known that the non-linear propagation of coherent LPs in UT system is well modeled with the non-linear interference (NLI) [ref] noise made up of the self- (SCI) and cross- (XCI) channel interference produced by a channel under test (CuT) on itself and by the other co-propagating channel. The gaussian noise (GN) model [ref] implemented in available open source QoT-E tools as GNPY [ref] provides adequate NLI estimation. The physical mechanism allows for a spatially and spectrally disaggregated approach: as outlined in fig1, each span introduces its amount of NLI noise which can be modelled as additive white gaussian noise (AWGN) source, possibly independent on the propagation history, and each channel (CuT included) its contribution per span on the CuT [ref continuum]. Such disaggregated features are crucial

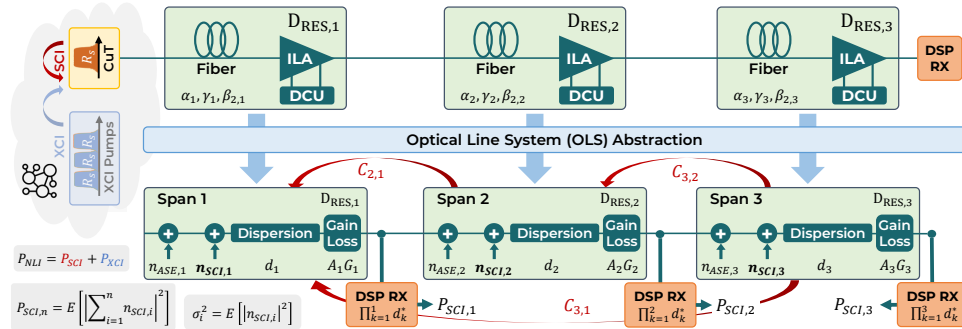

Fig. 1. 3x span example of mixed fibers UT/DM optical system (up) and its system abstraction (down). In simulation we receive at the end of all the spans to obtain the P_{SCI} accumulation.

in open and reconfigurable networking as not all the channel details (e.g. modulation format) or their propagation history may be known (e.g. alien wavelengths). Also, especially in the metro segments, OLS are typically far from being uniform links, exposing instead mixed fiber types. When considering DM OLS, the same approach may hold, however the limited residual dispersion per span $D_{RES,i}$ set by DCUs severely enhances SCI intensity due to its spatial coherent accumulation. Also, a proper estimation of the SCI coherence is important also in UT scenario due to the market trend to the symbol rate enlargement, which makes SCI predominant w.r.t. XCI. In this work we prosecute the development of the disaggregated model for coherent SCI accumulation in mixed fiber OLSs including DM and UT spans, presented in [ref ecoc] to the undistorted CuT case. We show that the coherence correction scales well in mixed fibers scenario and restores a conservative overall estimation of the generalized signal to noise ratio (GSNR) w.r.t. to the case where the plain incoherent GN (IGN) model is used for SCI evaluation under the hypothesis of C-band partial and full spectral load.

2. SSFM Simulation and SCI Coherence Modeling

We here review and update the model development started in [ref ecoc]. As reported in Fig.??, we first focus on the propagation of a single coherent channel on the OLS. Each span introduces its own *pure* SCI contribution which is modeled as an additive noise field $n_{SCI,i}$, equivalently put at the fiber start, whose intensity is σ_i^2 and is well modeled by the IGN model. Each noise field propagates throughout the OLS and gets the effects of dispersion d_i (which includes the DCU compensation), gain G_i and loss A_i of the subsequent fiber spans. We assume that the OLS is operated in transparency, so that $A_i G_i = 1$. Since each SCI term is generated by the same channel data sequence, the contributions of two spans i, j are correlated and sum up coherently at the receiver after electronic dispersion compensation. The correlation between the i -th and j -th terms is accounted for by the $C_{i,j}$ coefficient, which decreases with the amount of dispersion accumulated between span j and span i , $i < j$. Note that under strong coherence, the SCI is not anymore spatially disaggregated as it thus depends on the LP propagation history. However, during path computation we know the parameters of the candidate crossed path, so it would be possible to reconstruct the coherence. Hence, the amount of total SCI noise introduced by the i -th span $\Delta P_{SCI,i}$ is:

$$\Delta P_{SCI,i} = \sigma_i^2 + 2 \sum_{j=1}^{i-1} C_{i,j} \sigma_i \sigma_j \quad (1)$$

hence, we estimate the overall SCI by knowing the *pure* terms and the correlation coefficient $C_{i,j}$. We tested **1** with a large split-step Fourier method (SSFM) based simulation campaign, considering uniform OLS (all spans have the same physical parameters) and mixed fibers OLSs. In **2** we report the $\Delta P_{SCI,i}$ evolution of a 400ZR channel ($R_s = 64$ GBaud, DP-16QAM) on a uniform OLS made of 16x 80km long SSMF fibers spans with inline residual dispersion of $D_{RES} = 40$ ps/nm at end of each span, a typical value for DM OLS. We put a coherent DSP receiver at the end of each span to measure the accumulated $P_{SCI,i}$ and calculated $\Delta P_{SCI,i} = P_{SCI,i} - P_{SCI,i-1}$. All the simulations here and throughout the paper have been done with ASE noise generation turned off to isolate only the NLI (SCI) noise. We have first simulated the *full* overall SCI (squares marker) without predistortion of the CuT (blue curve), as when the LP gets deployed, and with 102400 ps/nm of predistortion (red curve), as a channel which has already accumulated dispersion in a previous network segment. The pure SCI σ_i^2 is obtained by turning off the Kerr effect ($\gamma = 0$) in all the spans except the i -th (green curves). The $C_{i,j}$ coefficients instead are derived from **1** from simulation with $\gamma = 0$ in all the spans except i -th and j -th, always with predistortion applied. We have thus collected the $C_{i,j}$ s from several link configurations involving different dispersion and loss coefficients and inline residuals arranged in uniform and mixed configurations and found that the $C_{i,j}$ s scales almost

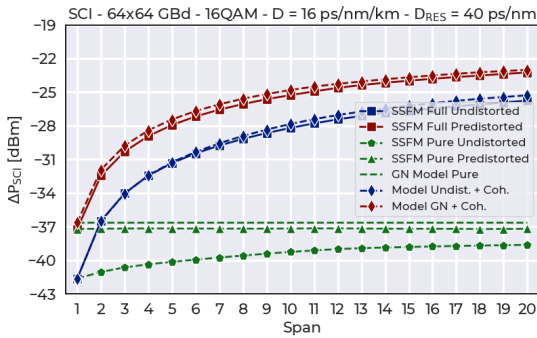

Fig. 2. $\Delta P_{SCI,i}$ accumulation

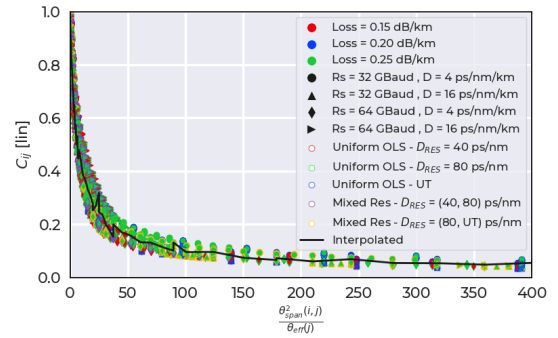

Fig. 3. Sample figure with preferred style for labeling parts.

universally with the ratio between $\theta_{span}^2(i, j) = (R_s^2 \pi \sum_{k=j}^{i-1} (\beta_{2,k} L_s + \beta_{DCU,k}))^2$ and $\theta_{eff}(j) = R_s^2 \beta_{2,i} L_{eff,i}$. The former is set by the amount of dispersion accumulated from span j to $i-1$, the latter by the j -th dispersion coefficient and effective length, as shown in fig3. From this dataset we obtain an interpolated curve (black) from which we pick the c_{ij} once the parameter $\theta_{span}^2(i, j) / \theta_{eff}(j)$ for whatever OLS configuration. fig 1 shows that the GN model well intercets the pyure SCI when predistortion is applied (trangles) conservatuovevly. When the channel is undistorted instread, a slow gaussianization [ref egn] is observed due to the small D_{RES} . With such inline compensation, the overall SCI is around 10 dB larger that the pure terms due to the strong coherence. We have thus tested the model and reconstructed the coherence using eq1 (dashed curves). predistorted curve is built using the pure σ_i^2 obtained with GN model, while the undistorted model curve employes the SSFM-simulated undisrtd pure terms, though they could be obtained analytically using analytical tools available in literature [ref egn, dar]. c_{ij} s are obtained from the interpolated black curve of fig3. In both of the cases, the model follows consrevatively the full ssfm curves with a great accuracy. Since the c_{ij} s are obtained by predistorted simulations in both cases we can also consider the coherence effect as substantially independent upon gaussianization from a practical point view. Indeed, gaussianization is a phenomenon involving the pure term, intrinsic tyo the i -th span, while coherence involves the interaction between the contribution of different spans.

3. GSNR Estimation for QoT-E

DSP configuration? we have seen that not taking into account properly the coherent SCI acculation in DM OLSs may lead to underestimate the SCi contribution to NLI by several dB. We now assess how much such SCI underestimation impacts the overall GSNR evaluation. th GSNR considers the ASE noise contribution due to inline amplifiers (ILA)s and the NLI contribution due to SCI and XCI:

$$GSNR^{-1} = OSNR^{-1} + SNR_{SCI}^{-1} + SNR_{XCI}^{-1} \quad (2)$$

To this aim we have considered two mixed fiber OLSs of 10x fiber spans. Both are made of 4x spans of LEAF-like fiber + 4x TrueWave-like + 2x SSMF fiber. All fiber types have different loss, dispersion and non-linear coefficients. The first OLS is DM with, in order, 4x spans at $D_{RES} = 40$ ps/nm + 4x at $D_{RES} = 80$ + 2x in UT. Here

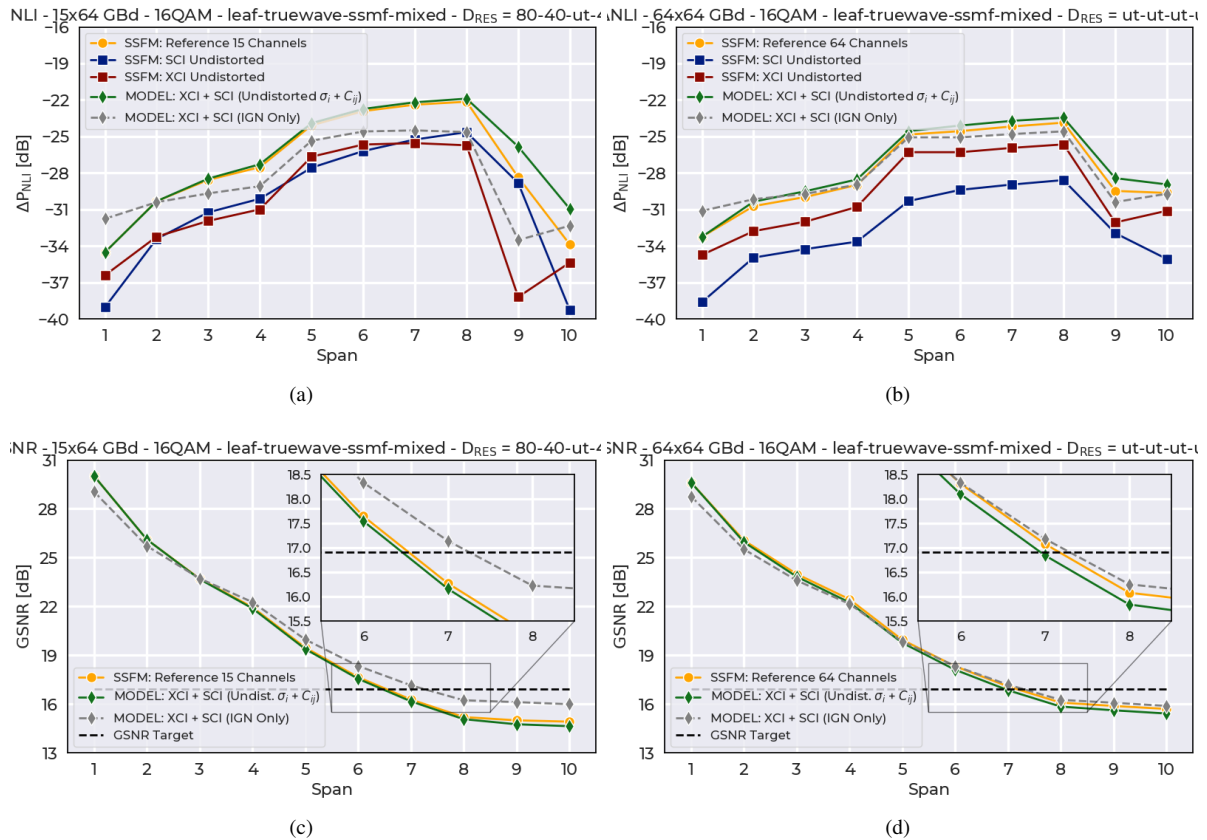

Fig. 4. Sample figure with preferred style for labeling parts.

we propagate 15x 400G channels (64 Gbaud, DP-16QAM, 75 Ghz WDM grid), undistorted at 1 dBm, being the CuT the center channel. This is a realistic scenario since when deploying coherent channels on DM OLSs, part of the spectrum is allocated to 10G channels and another portion must be kept as a guard-band between 10G and 400G channels [ref icecce]. In this case, the QoT degradation due to 10G channels has been neglected, although it maybe considered using the model in [ref icecce] In the second OLS all the spans are UT and we propagate 64x 400G channels filling the whole c-band being the CuT the 33-th channel. We have first simulated these two scenarios to obtain the overall NLI (SCI+XCI) accumulation curve (reference yellow curve in fig 4/5). Then, we have obtained the SNR_{XCI} contribution redoing the same simulation but with the CuT power at -20 dBm to make SCI negligible. The resulting NLI components introduced per span are reported in fig4. we first notice that the SCI power is comparable to the XCI of 15 channels in the DM OLS but it surpasses it at the 8-th span due to the large accumulated cohrency, while XCI is predominant in the UT OLS as the coherency is less intense. Fig. also reports the overall NLI estimation using the plain IGN (grey) and the coherent model of Eq. 1 for SCI. The XCI power is extrapolated from the reference simulation and added to the estimated SCI, as teh XCI in DM OLS is out of the scope of this work. We may notice that the model outcomes using IGN is never conservative, although the gap is small in the UT OLS. In the DM OLS the IGN solution underestimates SCI more tha 3 dB. The coherent model instead follows well the evolution in the mixed fiber OLS and always gives a conservative estimation.

As a last step, we use the estimated NLI to evaluate the accumulated GSNR at end of each span of the OLSs. The OSNR due to ASE noise is calculated assuming transparency and an EDFA noise figure of 4.5 dB. Fig. ?? plots the accumulatee GSNr at end of each span for the DM and UT OLSs for the reference SSFM simulation and the two modeling approaches. To demonstrate the implications of the SCI underestimation in path feasibility, we also indicate the GSNR threshold for DP-16QAM (16.7 dB) of a commercial tranceiver.

As shown by the referce curve, the DM and UT OLS are able to cover trasnmission up to 6 and 7 spans, respectively. In the UT case, the IGN model approach works well in predicting the actual reach as the coherency is small. In the DM OLS instead the IGN approach overestimates the GSNR by about 0.7 dB, which would have led to a wrong estimation of the reach up to 7 spans. The coherency model of Eq. 1 instead correctly predicts the available GSNR with a negligible gap to the reference simulation.

4. Conclusions

We have presented a semi-analytical model able to properly predict the coherent SCI accumulation in both UT and DM OLS. We have shown that neglecting such effect in DM OLSs may lead to an overestimation of the GSNR and system reach in the path feasibility process.

References

1. E. Krishnan, A. M. Shan, T. Rishi, L. A. Ajith, C. V. Radhakrishnan, *On-line Tutorial on \LaTeX* , "Mathematics" (Indian \TeX Users Group, 2000), <http://www.tug.org/tutorials/tugindia/chap11-scr.pdf>.
2. C. van Trigt, "Visual system-response functions and estimating reflectance," *J. Opt. Soc. Am. A* **14**, 741–755 (1997).
3. T. Masters, *Practical Neural Network Recipes in C++* (Academic, 1993).
4. B. L. Shoop, A. H. Sayles, and D. M. Litynski, "New devices for optoelectronics: smart pixels," in *Handbook of Fiber Optic Data Communications*, C. DeCusatis, D. Clement, E. Maass, and R. Lasky, eds. (Academic, 1997), pp. 705–758.
5. R. E. Kalman, "Algebraic aspects of the generalized inverse of a rectangular matrix," in *Proceedings of Advanced Seminar on Generalized Inverse and Applications*, M. Z. Nashed, ed. (Academic, 1976), pp. 111–124.
6. R. Craig and B. Gignac, "High-power 980-nm pump lasers," in *Optical Fiber Communication Conference*, Vol. 2 of 1996 OSA Technical Digest Series (Optical Society of America, 1996), paper ThG1.
7. D. Steup and J. Weinzierl, "Resonant THz-meshes," presented at the Fourth International Workshop on THz Electronics, Erlangen-Tennenlohe, Germany, 5–6 Sept. 1996.