

XIX ANIDIS Conference, Seismic Engineering in Italy

Seismic analysis of medical equipment in Ospedale Mauriziano (Torino): a resilience-based approach

Lorenza Abbracciavento^a, Bernardino Chiaia^a, Valerio De Biagi^a, Anna Reggio^a

^a*Department of Structural, Geotechnical and Building Engineering (DISEG), Politecnico di Torino, Torino, Italy*

Abstract

Seismic vulnerability assessment is highly needed in the field of nonstructural components due to the key role they play, not only in terms of life safety, but also in terms of functionality and economic losses. In case of strategic buildings, and particularly hospitals, functionality strongly depends on a complex network of electrical, mechanical and specialty equipment, which are necessary to cope with the post-earthquake emergency state and ensure resilience. In this paper, results from seismic analyses performed on a major hospital (*Ospedale Mauriziano*) in Torino, Italy, are presented. First, facilities and medical equipment essential for the operational continuity of the hospital have been identified. Therefore, focusing on the Emergency Department, a case study concerning the seismic analysis of a Computerized Axial Tomography (CAT) scan has been developed and is here illustrated. Seismic verifications for the ultimate limit state (ULS) and the serviceability limit state (SLS) have been carried out in order to assess both the integrity and functionality of the CAT scan under earthquake loading. The proposed verification methodology is in agreement with the current Italian building code (NTC 2018) as well as with the most recent criteria and recommendations from international seismic standards.

© 2023 The Authors. Published by Elsevier B.V.

This is an open access article under the CC BY-NC-ND license (<https://creativecommons.org/licenses/by-nc-nd/4.0>)

Peer-review under responsibility of the scientific committee of the XIX ANIDIS Conference, Seismic Engineering in Italy.

Keywords: hospitals; seismic resilience; operational continuity; nonstructural components; medical equipment.

1. Introduction

Seismic analysis of nonstructural components has received much attention in recent years due to the relevant nonstructural damages, and consequent losses (casualties, repair/replacement costs, downtime), observed in essential facilities affected by earthquakes (FEMA E-74:2012; Filiatrault and Sullivan 2014).

Essential or critical facilities are the ones whose functionality is vital to emergency response and recovery after a disaster event: among the others, examples are medical care facilities, civil protection facilities (fire, police, emergency operations center), schools, power plants. According to the concept of seismic resilience (Bruneau *et al.*

2003), essential facilities are required to remain in operation during and after the seismic event (Operational performance level). Ensuring this resilience objective requires, in particular, the harmonization of performance levels between structural and nonstructural components: even if structural components achieve the operational performance level, failure of architectural components or of mechanical, electrical, and plumbing (MEP) components can lower the seismic resilience of the entire facility (Bruneau and Reinhorn 2007; Cimellaro *et al.* 2010; Parise *et al.* 2013, 2014). In the specific case of hospitals and acute care facilities, the operational continuity critically depends also on the functionality of specialty medical equipment, which could have life supporting functions and are often high-tech and target of significant economic investments.

In this paper, results from the seismic analyses performed on a major hospital (*Ospedale Mauriziano*) in Torino, Italy, are presented. The focus is on the analysis and verification of essential medical equipment related to the service continuity of the Emergency Department. A case study concerning a Computerized Axial Tomography scan is developed. The aim of the study is to illustrate a methodology for assessing both the integrity and functionality of medical equipment under earthquake loading. The proposed methodology adopts a resilience-based approach and is in agreement with the current Italian Building Code (NTC 2018) as well as with the most recent criteria and recommendations from international seismic standards (FEMA E74:2012; FEMA 356:2000; ICC AC-156:2010).

2. Case study

Ospedale Mauriziano “Umberto I” is an articulated hospital complex consisting of 17 buildings, covering a surface of approximately 50 000 m² within a perimeter of about 900 m (Figure 1(a)). The initial construction dates to 1885, but new buildings, extensions and elevations have been added over time till nowadays.

The Emergency Department of the hospital is housed in the building named Pavilion 17 (Figure 1(b)), built in 1996 and subsequently extended in 2010. The supporting structure of the building is a 4 storeys reinforced concrete frame, the floor system is given by reinforced concrete uniform slabs with orthotropic behaviour. Regularity in plan and in elevation and an in-plane diaphragm behaviour of the floor slabs are assumed in the seismic analyses.

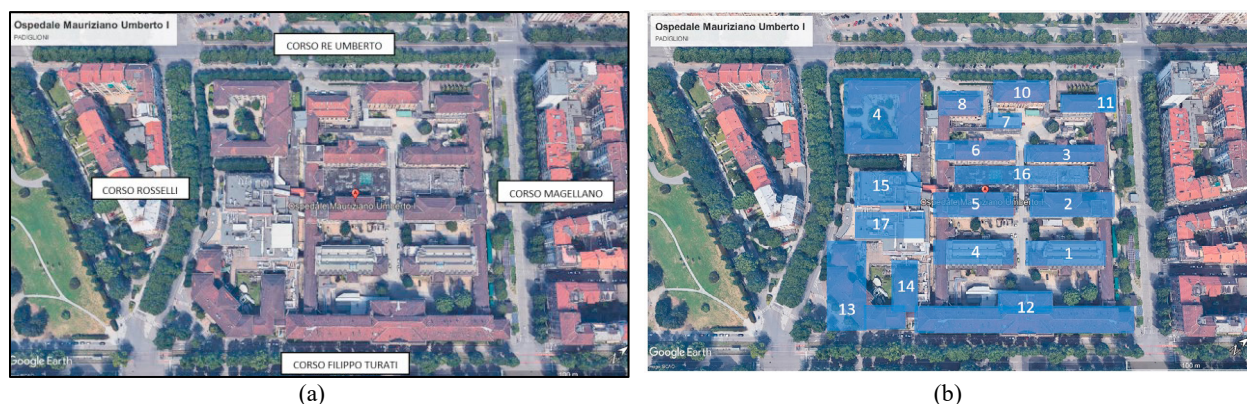

Fig. 1. Ospedale Mauriziano “Umberto I”, Torino, Italy: (a) aerial view of the hospital complex; (b) denomination of the buildings (pavilions) that form the hospital complex, the Emergency Department is in Pavilion 17.

2.1. Resilience-based approach

The concept of resilience is broadly used in several disciplines ranging from ecology, psychology and economics to materials science and engineering. In the conceptual framework provided by Bruneau *et al.* (2003), engineering resilience has been defined as the ability of a system to reduce the chances of a shock (abrupt reduction of performance), to absorb such a shock if it occurs, and to recover quickly afterwards (reestablish normal performance). Focusing on earthquake disasters, and specifically on post-disaster response, seismic resilience can be achieved: by enhancing the ability of a community’s structures and infrastructures to perform during and after an earthquake (Chiaia

et al. 2019); through an emergency response that effectively copes with and contains losses; through recovery strategies that enable the community to return to levels of pre-disaster functioning as rapidly as possible.

From this perspective, an adequate seismic resilience of hospitals and other acute care facilities is strongly needed. In this case study, the Emergency Department of Ospedale Mauriziano has been selected because: i. the continuing operation of the Emergency Department is needed to ensure the seismic resilience of the entire hospital system; ii. from an engineering point of view, its building is characterized by a close interdependency between performance levels of both structural and nonstructural components. In particular, we emphasize the pivotal role played by specialty medical equipment to the aim of service continuity. Among the equipment items surveyed in the Emergency Department, a Computerized Axial Tomography (CAT) scan is examined, drawing attention to its relevance to the service continuity of the Emergency Department and to its considerable economic cost. Following a resilience-based approach, seismic analyses expressly investigate both the integrity and functionality of the equipment item under seismic loading.

2.2. Description of the CAT scan

A CAT scan is an imaging diagnostic medical device which, through the emission of X-rays, allows the internal visualization of the entire body and of specific anatomical sections. The scanner system is composed by hardware terminals and software support, both finalized to the acquisition of patient data in form of images.

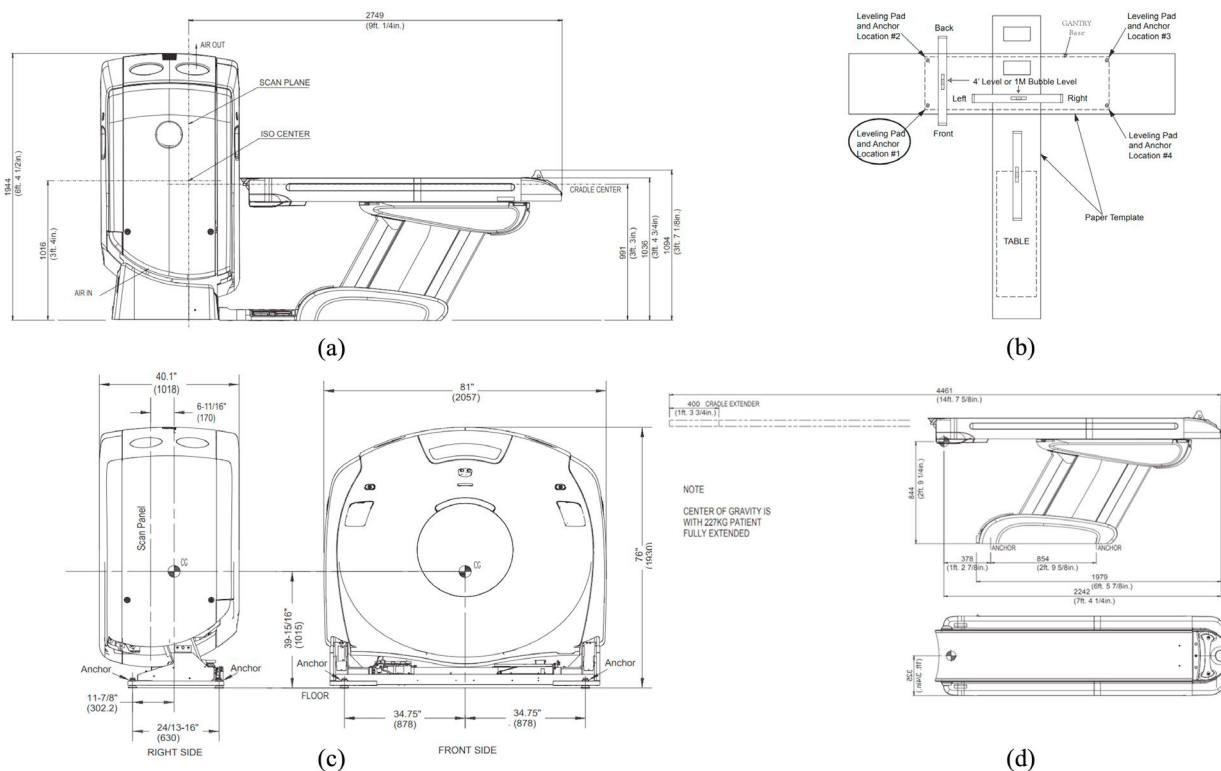

Fig. 2. Computerized axial tomography (CAT) scan: (a) lateral view of the body scanner, composed of gantry and patient table; (b) position of anchoring base plates, upper view; (c) gantry component of the body scanner, side and front views; (d) Patient table component of the body scanner, side and upper views.

The CAT scan considered in the present study (Figure 2) consists of two units, named as *gantry* and *patient table*. Figure 2(a) shows the relative position of gantry and patient table in the operative configuration: the upper platform of the patient table can move laterally and passing through the opening gate of the gantry. In

Figure 2(b), the layout of anchorages is represented: gantry and patient table are independently anchored to the floor system of the supporting structure. In Figures 2(c) and 2(d), detailed views of gantry and patient table are illustrated.

The gantry, or the “gate” of the body scanner, is the hardware part in which X-rays are generated and emitted. As shown by the figures, the gantry has a central opening through which the patient-table moves. The mass of the gantry is estimated at 1770 kg. The gantry has a height of 1930 mm and dimensions of 1018 mm in the longitudinal direction and 2057 mm in the transverse direction (Figure 2 (c)). The height of the centre of mass with respect to the base is 1015 mm.

The patient-table is similar in size to a bed on which the patient’s body is placed in supine position. It can extend and move, along its longitudinal axis, with respect to the fixed base and to the gantry. The mass of the patient table is estimated to be around 545 kg, including a reference patient’s mass of 105 kg. The length of the upper platform is 2242 mm in folded configuration, 4461 mm in open configuration; the width is 650 mm; the distance of the center of mass with respect to the base is 844 mm (Figure 2 (d)).

The anchoring system is made in compliance with the technical specifications provided by the Manufacturer. Both the gantry and the patient table are floor-mounted and rigidly anchored to the supporting structure, with no lateral support. For the gantry, the anchoring system includes a rectangular base plate measuring 700x1966 mm with 4 round levelling pads, each one 65.5 mm thick, in contact with the concrete floor. The attachments are 4 tie-down bolts with 12.7 mm diameter and 203 mm length. For the patient table, the base plate measures 433x1460 mm and is anchored by way of 4 tie-down bolts and levelling pads of the same dimensions as the gantry.

2.3. Seismic vulnerability of the CAT scan

The seismic vulnerability of nonstructural components is affected by several factors, among which: the type of nonstructural component; the position of the component within the supporting structure; the anchorage system of the component to the structure.

Each type of nonstructural component responds in a different manner when subjected to seismic excitation and exhibits its own failure modes, showing sensitivity to one or more structural response parameters. According to the FEMA standards (FEMA 356:2000; FEMA E74:2012) classify seismic vulnerable nonstructural components into two categories, depending on their sensitive response parameter:

- deformation-sensitive components;
- acceleration-sensitive components.

Nonstructural components that are sensitive to and subjected to damage from the deformation of the supporting structure are classified as *deformation-sensitive* components. This is typically the case of architectural components, suffering from excessive inter-story drifts (e.g., glass panels, partitions, masonry infills, ...), or plumbing components, suffering from differential displacements across seismic joints.

Nonstructural components that are sensitive to and subjected to damage from inertial loading are classified as *acceleration-sensitive* components. This is typically the case of mechanical, electrical and electronic components as well as major specialty equipment items. Correlated failure modes are of two kinds:

- for unanchored or inadequately anchored components, damage may be caused by the excessive sliding, rocking or overturning of the component, possibly involving life safety threats due to dislodging and falling;
- for adequately anchored components, seismic accelerations transmitted to the component may become intense enough to cause damage to internal hardware, as suffered by equipment like computers, communications systems and medical equipment.

The CAT scan considered in this study can be classified as an acceleration-sensitive component. As declared in the technical manual by the Manufacturer, the equipment exhibits the most sensitivity to vibration and suffers an impaired functionality in a band of frequencies including the resonant frequencies of gantry and patient table. The resonant frequencies vary depending on the operating conditions of the equipment, falling within the following ranges: for the gantry, 8 - 14 Hz; for the patient table, 2 - 10 Hz.

3. Seismic analysis and verifications

3.1. Performance objectives

The methodology adopted by the Italian Building Code (NTC 2018) for seismic design and verification is *performance-based, multi-objective* and *multi-strategy*. As shown by Table 1, buildings are assigned target performance objectives defined according to the following criteria:

- a. increasing performance objectives are associated with increasing seismic hazard levels, leading to the definition of four limit states, two serviceability limit states (Operational, Immediate Occupancy) and two ultimate limit states (ULS) (Life Safety and Collapse Prevention);
- b. the definition of a performance objective for a specific building is related to the building's Importance Class, which depends on the social and economic consequences of collapse and on the building's importance for public safety and civil protection in the immediate post-earthquake. Importance Classes are four (I, II, III, IV), where classes I and II correspond to ordinary buildings and classes III and IV correspond to public and critical facilities, similarly to Eurocode 8 (EN 1998-1:2004);
- c. the target performance objective is assigned to the whole building system, hence involving both structural and nonstructural performance levels.

In the present case study, Ospedale Mauriziano is a major hospital, which is given an Importance Class IV. Concerning the performance objectives required to the CAT scan, we consider:

- i. an Operational performance level as to the serviceability limit state verification: it must be verified that the accelerations induced by seismic loading do not cause an interruption in the operation of the equipment;
- ii. a Life Safety performance level as to the ultimate limit state verification: it must be verified that the equipment anchorages are able to resist the seismic force transferred by the equipment, so that the equipment is prevented from dislodging and overturning.

It is worth noting that the Italian Building Code does not assign expressly performance objectives to specialty equipment in critical facilities, as medical equipment in hospitals can be defined. Provisions of the code are limited to nonstructural architectural components and nonstructural MEP components (see Table 1, adapted from Table 7.3.III of NTC 2018). However, by referring to the rationale of the Italian Building Code, in this case study we assign to essential medical equipment in hospitals the same performance objectives required by the code to MEP components in class IV buildings.

Table 1. Limit states under seismic loading as per the Italian Building Code (adapted from Table 7.3.III, NTC 2018): serviceability limit states, SLS, Operational (O) and Immediate Occupancy (IO); ultimate limit states, ULS, Life Safety (LS) and Collapse Prevention (CP). Depending on the building's Importance Class (IC), the relevant limit states are given for structural components (ST), nonstructural architectural components (NS) and nonstructural mechanical, electrical and plumbing components (MEP).

Limit States		IC I		IC II		IC III and IC IV		
		ST	ST	NS	MEP	ST	NS	MEP
SLS	O					X		X
	IO	X	X			X		
ULS	LS	X	X	X	X	X	X	X
	CP		X			X		

3.2. Seismic loading

According to the Italian Building Code, we determine the effects of seismic loading on the CAT scan by applying a horizontal seismic force

$$F_a = \frac{S_a W_a}{q_a} \quad (1)$$

to the equipment's centre of mass in the most unfavourable direction, being

S_a the maximum absolute acceleration, normalized with respect to gravity acceleration g , experienced by the equipment during the ground shaking, for the seismic hazard level of the considered limit state;

W_a the operating weight of the equipment item;

q_a the behaviour factor of the equipment.

The absolute acceleration S_a experienced by an equipment item, or by a nonstructural component in general, anchored at a specific floor of its supporting structure, can be represented as a function of the fundamental vibration period T_a of the component: this representation is called floor response spectrum $S_a(T_a)$. Floor response spectra are affected in a quite complex manner by several parameters (filtering effect of the supporting structure, location of the nonstructural component within the structure, anchorage configuration, frequency tuning, nonlinearities) (Reggio 2011). In the present case study, the supporting structure is a regular frame, hence the Italian Building Code (NTC 2018 and Circ. C.S.LL.PP. 21/1/2019 n.7) allows us to assume the structural floor accelerations to vary linearly along the height of the structure, amplifying the ground acceleration, and to determine the floor response spectrum $S_a(T_a)$ using the following expressions:

$$S_a(T_a) = \begin{cases} \alpha S \left(1 + \frac{z}{H}\right) \left[\frac{a_p}{1 + (a_p - 1) \left(1 - \frac{T_a}{aT_1}\right)^2} \right] \geq \alpha S & \text{for } T_a < aT_1 \\ \alpha S \left(1 + \frac{z}{H}\right) a_p & \text{for } aT_1 \leq T_a \leq bT_1 \\ \alpha S \left(1 + \frac{z}{H}\right) \left[\frac{a_p}{1 + (a_p - 1) \left(1 - \frac{T_a}{bT_1}\right)^2} \right] \geq \alpha S & \text{for } T_a > bT_1 \end{cases} \quad (2)$$

where:

α is the ratio between the bedrock maximum acceleration a_g and the gravity acceleration g ;

S is the factor accounting for the soil category and the topography conditions; quantity αS is equal to the peak ground acceleration (PGA) at the base of the supporting structure, in units of gravity g ;

z is the height of the equipment item above the foundation level;

H is the total height of the supporting structure measured above the foundation level;

T_a is the fundamental vibration period of the equipment item;

T_1 is the fundamental vibration period of the supporting structure in the relevant direction;

a, b, a_p are dimensionless parameters given by the code depending on the value of T_1 .

With reference to the site of Ospedale Mauriziano, the soil class is B (deposit of very dense sand) and the seismic hazard levels, determined as per the Italian Building Code, are: for the Operational limit state, $\alpha S = 0.045 (g)$, corresponding to a probability of exceedance of 81 % in 200 years (mean return period of 120 years); for the Life Safety limit state, $\alpha S = 0.090 (g)$, corresponding to a probability of exceedance of 10 % in 200 years (mean return period of 1898 years). Regarding the supporting structure, the total height above the foundation level is $H = 16.84$ m, while the fundamental vibration period, in the direction of seismic analysis, is $T_1 = 0.59$ s. Given this value of T_1 , the code prescribes the parameters values $a = 0.3, b = 1.2, a_p = 4.0$. The height of the CAT scan above the foundation level is $z = 9.56$ m.

Figure 3 illustrates the floor response spectra determined for the CAT scan.

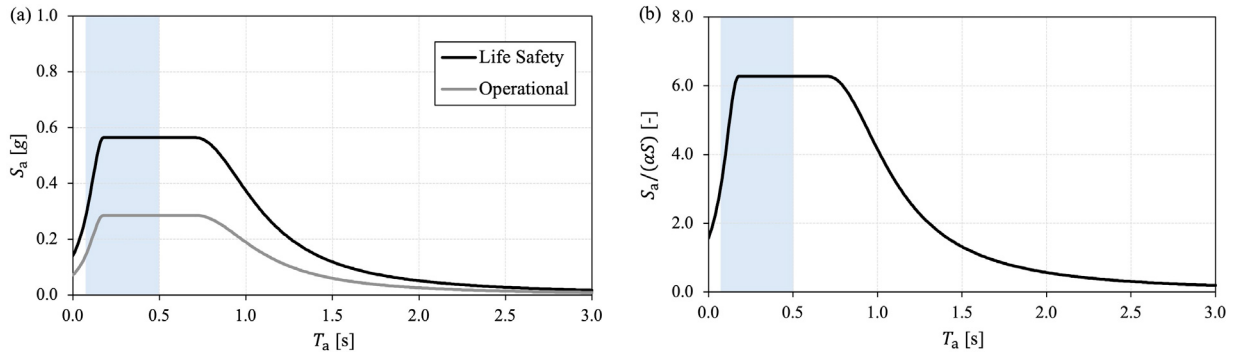

Fig. 3. For the CAT scan, floor response spectra determined according to the Italian Building Code (NTC 201 and Circ. C.S.LL.PP. 21/1/2019 n.7): (a) floor spectra for the Life Safety and the Operational limit states, in units of gravity g ; (b) floor spectrum normalized with respect to the PGA αS at the base of the supporting structure. The shadow area indicates the range of vibration periods of the CAT scan.

3.3. Life Safety limit state verification

As to the Life Safety limit state verification, we verify that the attachments between the CAT scan and the floor of the supporting structure resist the seismic force transferred by the equipment. The anchorages of the two units that compose the CAT scan, gantry and patient table, are made of tie-down bolts supplied by the Manufacturer and are independent of each other. Therefore, two different verifications have to be conducted.

The horizontal seismic force F_a acting on each unit of the CAT scan is estimated by applying Equation (1). Spectral acceleration $S_a(T_a)$ is given by the Life Safety floor response spectrum (Figure 3) as a function of the fundamental vibration T_a period of the equipment. In this regard, the Manufacturer declares resonant frequencies that vary depending on the operating conditions of the CAT scan; consequently, the fundamental vibration period ranges from 0.071 s to 0.5 s, as indicated by the shadow area in Figure 3. In applying Equation (1), we hence select, from the floor response spectrum, the maximum value assumed by spectral acceleration S_a in the aforementioned period range, $S_a = 0.564$ (g). The operating weight W_a of each unit is provided by the Manufacturer (17.36 kN for the gantry, 5.35 kN for the patient table). The behaviour factor is taken as $q_a = 1.0$ for both the units, not relying on the ductility capacity of either the equipment or the anchoring system.

The obtained seismic forces amount to $F_a = 9.80$ kN for the gantry and $F_a = 3.02$ kN for the patient table. For each unit, the seismic force F_a is considered as applied in the centre of mass and the loads acting on the anchoring bolts (shear forces and tension forces) are evaluated. Strength verifications of the anchoring bolts are carried out in compliance with the Italian Building Code (NTC 2018).

3.4. Operational limit state verification

As to the Operational limit state, we verify that the accelerations induced by the prescribed seismic loading do not cause an interruption in the functioning of the CAT scan. To accomplish this kind of verification, our methodology is based on the seismic qualification tests of the CAT scan, achieved by the Manufacturer by way of shake table testing in compliance with the standard ICC AC-156:2010 (*Acceptance criteria for seismic certification by shake-table testing of nonstructural components*, issued by the International Code Council).

The aim of seismic qualification tests on shaking table is to verify the capacity of a base-mounted component to resist seismically induced accelerations. In case of equipment items, the test is passed if the equipment maintains post-test integrity and functionality, considering both its internal hardware and its attachments. Biaxial dynamic tests were performed on the CAT scan by simultaneously applying input accelerograms in one principal horizontal axis and in the vertical axis. The suite of input accelerograms was generated to meet a target acceleration response spectrum, named Required Response Spectrum (RRS), which represents the seismic input for the component being qualified.

Figure 4 illustrates the floor response spectrum at the Operational limit state, determined according to the Italian Building Code, and the horizontal RRS from the CAT scan seismic qualification tests. By comparison, since spectral accelerations of the RRS are higher than those of the floor response spectrum, we can conclude that functionality and operational continuity of the CAT scan are verified under the seismic input at the Operational limit state.

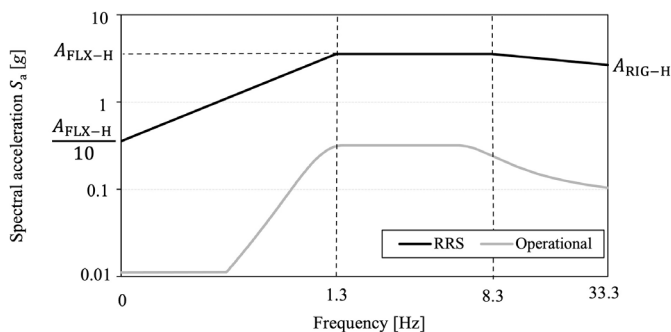

Fig. 4. Comparison between the floor response spectrum at the Operational limit state and the Required Response Spectrum (RRS) from the CAT scan seismic qualification tests. The floor response spectrum is determined according to the Italian Building Code (NTC 2018 and Circ. C.S.LL.PP. 21/1/2019 n.7). The RRS is in compliance with the standard ICC AC-156:2010. Parameters of the RRS are: horizontal spectral acceleration for flexible components $A_{FLX-H} = 3.2$ (g); horizontal spectral acceleration for rigid components $A_{RIG-H} = 1.74$ (g).

4. Conclusions

In this paper, a methodology for assessing both the integrity and functionality of specialty medical equipment under earthquake loading has been illustrated, with reference to a case study dealing with a major Italian hospital.

Based on the concept of seismic resilience, the focus is on essential equipment items in the Emergency Department. Two performance objectives have been assigned and verified for a CAT scan: Operational and Life Safety limit states. Seismic verifications have been carried out by determining the relevant floor acceleration response spectra, according to the current Italian building code (NTC 2018), and using the available seismic qualification data for the equipment, in compliance with the international standard ICC AC-156:2010.

Acknowledgements

The Authors would like to thank Ospedale Mauriziano for providing the data related to the case study. The support received by Technical Director Arch. Pier Luigi Armano and by Ing. Carla Jachino is gratefully acknowledged.

References

- Bruneau, M., Chang, S.E., Eguchi, R.T., Lee, G.C., O'Rourke, T.D., Reinhorn, A.M., Shinozuka, M., Tierney, K., Wallace, W.A., von Winterfeldt, D., 2003. A Framework to Quantitatively Assess and Enhance the Seismic Resilience of Communities. *Earthquake Spectra*, **19**, 733-752.
- Bruneau, M., Reinhorn, A., 2007. Exploring the Concept of Seismic Resilience for Acute Care Facilities. *Earthquake Spectra*, **23**, 41-62.
- Chiaia B., Barchiesi E., De Biagi V., Placidi L., 2019. A novel structural resilience index: definition and applications to frame structures. *Mechanics Research Communications*, **99**, 52-57.
- Cimellaro, G.P., Reinhorn, A.M., Bruneau, M., 2010. Seismic resilience of a hospital system. *Structure and Infrastructure Engineering*, **6**, 127-144.
- European Committee for Standardization (CEN), 2004. *Eurocode 8: Design of structures for earthquake resistance – Part. 1: General rules, seismic actions and rules for buildings*, EN 1998-1:2004., Brussels, Belgium.
- Federal Emergency Management Agency (FEMA), 2000. *Prestandard and Commentary for the seismic rehabilitation of buildings*, FEMA 356:2000. Washington, DC, USA.
- Federal Emergency Management Agency (FEMA), 2012. *Reducing the Risks of Nonstructural Earthquake Damage - A Practical Guide*, FEMA E-74:2012. Washington, DC, USA.
- Filiatrault, A., Sullivan, T. 2014. Performance-based seismic design of nonstructural building components: the next frontier of earthquake engineering. *Earthquake Engineering & Engineering Vibration*, **13**, 17-46.
- International Code Council (ICC), Evaluation Service, 2010. *Acceptance criteria for seismic certification by shake-table testing of nonstructural components*, ICC AC-156:2010. Washington, DC, USA.
- Ministero delle Infrastrutture e dei Trasporti, 2018. *Norme tecniche per le costruzioni*, D.M. 17/1/2018 (NTC 2018). Roma, Italy.
- Ministero delle Infrastrutture e dei Trasporti, 2019. *Istruzioni per l'applicazione dell'aggiornamento delle Norme tecniche per le costruzioni*, Circ. C.S.LL.PP. 21/1/2019 n.7. Roma, Italy.
- Parise, G., De Angelis, M., Reggio, A., 2014. Criteria for the definition of the equipment seismic levels: comparisons between USA and European codes. *IEEE Transactions on Industry Applications*, **50**(3), 2135–2141. DOI: 10.1109/TIA.2013.2289947.
- Parise, G., Martirano, L., Parise, L., De Angelis, M., Reggio, A., Weber, J., 2013. Seismic qualification of electrical equipment in critical facilities. *49th IEEE/IAS Industrial and Commercial Power Systems Technical Conference, I & CPS 2013*, Stone Mountain, GA, USA, April 30- May 3.
- Reggio, A., 2011. *Innovative technologies for the vibration control of equipment in critical facilities*. PhD Dissertation, Sapienza University of Rome, Rome, Italy.