

Air path and combustion controls coordination in diesel engine

Original

Air path and combustion controls coordination in diesel engine / Ventura, Loris; Malan, Stefano. - ELETTRONICO. - (2022), pp. 354-359. (Intervento presentato al convegno Proceedings of the 2022 22nd International Conference on Control, Automation and Systems tenutosi a BEXCO, Busan, Corea del Sud nel Nov. 27-Dec. 01, 2022) [10.23919/ICCAS55662.2022.10003917].

Availability:

This version is available at: 11583/2973684 since: 2023-02-13T13:25:26Z

Publisher:

Institute of Control, Robotics and Systems (ICROS)

Published

DOI:10.23919/ICCAS55662.2022.10003917

Terms of use:

This article is made available under terms and conditions as specified in the corresponding bibliographic description in the repository

Publisher copyright

IEEE postprint/Author's Accepted Manuscript

©2022 IEEE. Personal use of this material is permitted. Permission from IEEE must be obtained for all other uses, in any current or future media, including reprinting/republishing this material for advertising or promotional purposes, creating new collecting works, for resale or lists, or reuse of any copyrighted component of this work in other works.

(Article begins on next page)

Air path and combustion controls coordination in diesel engine

Loris Ventura^{1*} and Stefano A. Malan²

¹Department of Energy, Politecnico di Torino,
Corso Duca degli Abruzzi 24, 10129, Torino, Italy (loris.ventura@polito.it) * Corresponding author

²Department of Electronics and Telecommunications, Politecnico di Torino,
Corso Duca degli Abruzzi 24, 10129, Torino, Italy (stefano.malan@polito.it)

Abstract: The tightening of the diesel pollutants emissions regulations has made the performances obtainable from steady-state map controls, commonly employed in Internal Combustion Engine (ICE) management, unsatisfactory. To overcome these performance limitations, control systems have to cope with the engine transient operation conditions, coupling between its subsystem dynamics, and the trade-off between different requirements to efficiently manage the engine. The work demonstrates the deployment of a reference generator that coordinates the air path and combustion control systems of a turbocharged diesel engine for heavy-duty applications. The control system coordinator is based on neural networks and allows to exploit the best performance of the two control systems. The key idea is to generate air path targets, intake O_2 concentration and Intake MANifold Pressure (IMAP), coherent with the ones of the combustion control system, engine load and engine-out Nitrogen Oxides (NO_x). In this way, the air path control system provides the global conditions for the correct functioning of the engine, while, in cooperation, the combustion control will react to fast changes in the engine operating state and compensate for the remaining deviations with respect to load and NO_x targets. Reference generator networks are suitable for further real-time implementation on rapid-prototyping hardware and their performance was overall good.

Keywords: Diesel engine, Pollutant reduction, Neural Network models, Control system coordination.

1. INTRODUCTION

As global concern for the environment grows, legislators tightens the ICE pollutants emission regulations. In response to this action, automotive manufactures have introduced, particularly for diesel engines, a broad range of technologies: Exhaust Gas Recirculation (EGR) with Variable Geometry Turbochargers (VGTs) [1], high pressure common rail injection systems [2], advanced combustion control and innovative combustion concepts [3, 4], for example. Recently diesel engine research focus has shifted towards the development of modern control strategies [4, 5]. This was supported by the overall computational performance improvement of Engine Control Units (ECUs).

The importance of a coordinator between air path and combustion controllers is paramount. Targets for the two control systems have to be generated considering the different time dynamics and actual working conditions of the two systems. The main reason for the sometime poor performance of the two control systems is the mismatch between the actual and reference values of key variables used for the target generation. The two control systems are independent, but the air path and combustion subsystems are strongly coupled and, with this bias, the reference generator will work in conditions that differ from the expected ones.

Models make it possible to determine and exploit online the relations between key variables. Instead of using fixed open-loop reference signals, a good value for the reference can be generated based on available information. This can be exploited to manage the different control systems avoiding conflict. In this work, a coordinator

constituted by neural networks has been used to manage the air path and combustion control systems through their respective target signals. Air path and fuel path control system dynamics are different, with the first one being slower than the latter one. The coordinator generates a target for the air path control system based on the desired setpoint, the state of the engine and injection control system. The design choice was to use the air path control system to provide the global conditions needed to retrieve the desired performance and the injection control system to locally adjust the residual part and react to perturbations while guaranteeing the load. Furthermore, during the optimization of the control point, also the preferred actuator for the required control action can be evaluated.

In the literature only few examples of air path and combustion control systems coordinators emerged. In [6] controllers were coordinated by a high-level structure that considered combustion half way point, maximum pressure, rate of combustion, combustion instability and Indicated Mean Effective Pressure (IMEP) obtained from in-cylinder pressure measurement as states to generate the correct references. A dedicated PI control loop was applied to each cylinder. All the loops managed fuel quantity and Start Of Injection (SOI). Instead, the air path controller targeted Air Mass Flow rate (MAF) and IMAP.

In [7] a supervisory Model Predictive Control (MPC) approach that manages nonlinear controllers is developed for an air path system for multi-mode operation in a diesel engine. The whole controller includes three parts: supervisory MPC as target setpoint coordinator, actuator level nonlinear control, state detection either by virtual sensor or by ECU sensor. The actuators nonlinear control compensate the error dynamic. In this study, the coordina-

tion dynamics are modeled by a set of first order transfer functions. Only the MAF variable of air path, intake O_2 concentration and the O_2 concentration at the compressor inlet are considered.

Paper [8], through an MPC, regulates both air path and combustion in a diesel engine running partially premixed combustion. In the air path MAF and IMAP are managed by EGR and VGT actuators. While the combustion is managed through the main injection duration. The control structure featured an MPC with a Kalman filter to compensate for the model mismatches. Still, the references for the target variables were coming from maps and models obtained from a sensitivity analysis.

Dealing with single control systems employed on ICEs, they are usually based on the feed-forward architecture, relying on steady state maps, or on the closed-loop architecture through the use of PIDs [9]. These control systems lack of effectiveness particularly during transient operations. Nonetheless, their strong points of simple design and implementation made them to be widely adopted by the industry. But the pollutants emission reduction demanded by current regulations have pushed the development of modern model-based controllers. Several examples of model-based controllers have been reported in the literature, such as Multiple Input Multiple Output (MIMO) eigenvalue placement [10], predictive control [11] and H_∞ [12], but control strategies as neural network and fuzzy control [13] are also of interest regardless their complexity and counter-intuitive parameter tuning.

As well as the control layout, the targeted variables play a crucial role. IMAP and MAF have been extensively exploited due to the dedicated sensors installed on production engines. In this work intake O_2 concentration has been selected as controlled variable instead of the fresh MAF. This because the MAF is not strictly connected to pollutants, consequently emission control through its use is not easy and effective. Alternative variables with a closer connection with pollutants are EGR flow and fraction or λ (i.e., relative air-to-fuel ratio) [14].

Still, the benefits deriving from the employment of these control methodologies could be jeopardized by the lack of coherent references that are provided to them.

In this paper, section 2, the target engine together with the air path and combustion control systems are briefly described and referenced for more details. Section 3 firstly describes the coordinator layout and functioning, then its training and validation performance in steady-state and concludes by presenting simulation results over two transient tests. Section 4 provides the conclusion of the work.

2. PROBLEM DEFINITION

The engine considered in this work is a diesel FPT FIC 3-litre EURO VI and its main specifications are reported in Table 1. It is endowed with High-Pressure EGR (HP-EGR), EGR cooler, VGT, Exhaust flap and Inter cooler (Figure 1).

Table 1. FPT FIC Engine Main Specifications

Engine type	FPT FIC Euro VI diesel engine
Number of cylinders	4
Displacement	2998 cm ³
Bore x stroke	95.8 x 104 mm
Rod length	160 mm
Compression ratio	17.5 : 1
Valves per cylinder	4
Turbocharger	VGT type
Fuel injection system	High Pressure Common Rail

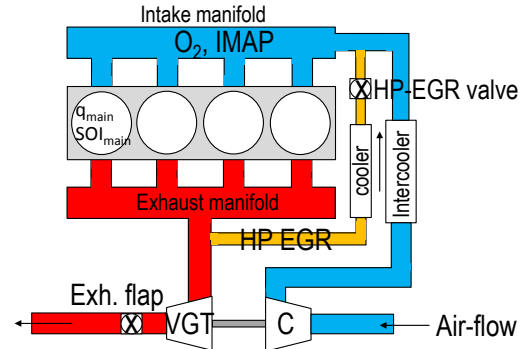

Fig. 1. FPT FIC Engine scheme.

The engine has been endowed with an O_2 concentration sensor in the intake manifold. Even though the engine complexity increases, the direct measurement allows a precise monitoring of the intake oxygen concentration. Furthermore the acquired data can be exploited by dynamic models to obtain more precise output predictions.

2.1 Air path control

A NonLinear Quadratic Regulator (NLQR) system for the HP-EGR loop regulates the intake O_2 concentration and the IMAP. The designed control system embeds in it two Multiple Input Single Output (MISO) Nonlinear AutoRegressive with eXogenous input (NARX) models. One network forecasts the intake O_2 concentration and the other the IMAP. They are both characterized by 2 hyperbolic tangent hidden neurons and one-neuron linear output layer. Five inputs are exploited by the networks: the actual values of the intake O_2 concentration or IMAP, engine speed, engine Brake Mean Effective Pressure (BMEP), the position of the HP-EGR and VGT valves.

Recurrent Neural Networks (RNNs) allowed to use only a single model to identify the different I/O pairs non-linear correlations over the whole engine operating range. Furthermore, their low computational time suits for ECU implementation. The details of the air path control system can be found in [15]. As a comparison, in the linear case multiple models are required to cover the whole engine functioning range: examples of linear black-box models can be found in [10] and in [16]. Instead in [17] an example of physical model is reported.

2.2 Combustion control

A cycle-to-cycle closed-loop combustion controller manages the engine BMEP and NOx emissions of the FIC diesel engine. The two target variables are regulated by manipulating the injected main pulse fuel quantity q_{main} and its SOI. The closed-loop controller exploits the feedback from a predictive combustion model used as a virtual sensor and calibrated on actual test bench measurements. This model can run with or without physical sensor feedback. The latter case allows not to use direct in-cylinder pressure measurement.

The control system comprises two separate loops implementing PI and lag regulators, one to control the engine load and the other one the NOx. Then, the feedforward term contribution allows considering steady-state nominal values for the two command actions. The structure allows independent control of all the four cylinders so that eight regulators are used, two per cylinder. Details of the feedback model can be found in [4] while a deeper description of the control system is in [18].

3. COORDINATOR

This section introduces the neural networks control systems coordinator. First, the coordinator structure and its functioning are presented in section 3.1. Then training and validation performance are shown in sections 3.2 and 3.3. A detailed GT-Power model of the engine was used to generate the separate datasets on which the nets were trained and validated. Model training and validation have been performed by the MATLAB Deep Learning Toolbox. At last, in section 3.4, the coordinator feasibility is further tested by simulations in transient conditions.

3.1 Structure

High-level coordination of air and fuel control systems is essential in meeting the conflicting needs between emissions, fuel economy and driveability. Figure 2 depicts an overview of the developed coordination strategy.

The coordinator is the fulcrum of the combined engine air path and combustion management: it adapts control targets harmoniously in order to meet the various conflict-

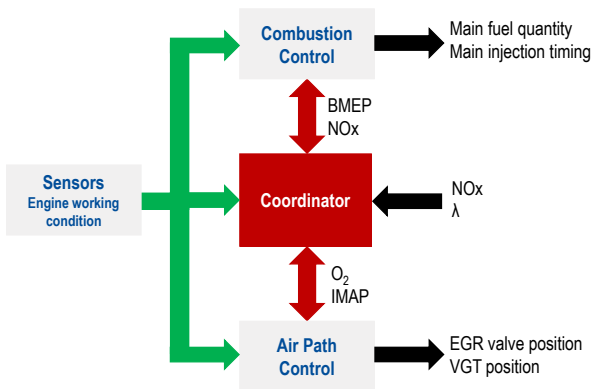

Fig. 2. Coordinator structure

ing performance requirements. The coordinator underwent several development stages. First, preliminary studies were carried out in MATLAB/Simulink using available steady-state and transient experimental tests to ensure the viability of the method. The second stage involved software in the loop testing in co-simulation between Simulink and GT-Power.

In the structure shown in Fig. 2, a clear separation between the two control systems is visible. The coordinator sets the target (O_2 concentration and IMAP) for the air path controller but does not do the same for the combustion controller. The combustion control system receives as target the same NOx setpoint that the coordinator uses to generate the O_2 reference while the BMEP is imposed by the driver or time varying profiles in simulation. It is important to remark that the red arrows in Fig. 2 are bidirectional. As a consequence, the coordinator not only sends the targets to the control systems but at the same time receives feedback from them. The coordinator is intended to make the air path control system, the slowest, work as desired while the combustion controller compensates for the remaining mismatches. In other words, the air path controller has to provide the global condition for the engine to run and to allow the combustion control system to fulfill the requested torque. In addition, the combustion control compensates for fast variations and offsets in both load and NOx emitted pollutants.

Another distinction inside the air path target generation has also been made to have complete control over the air path. The primary target is the intake O_2 concentration that is strictly correlated to the NOx pollutant emissions. The second target, the IMAP, was chosen to be subjected to the λ . In this manner, complete and separate management of the engine air path can be guaranteed. The target signals are generated in accord with each other, i.e., using as inputs the signals exploited or manipulated by the control systems. In this way, the control systems work coherently toward the same primary goal: NOx emission reduction. To this aim, two separate networks were used, one for the O_2 and one for the IMAP. The first net inputs are the engine speed, engine BMEP, SOI_{main} , rail pressure, desired NOx and λ to produce an oxygen target. The second one uses injected fuel quantity, O_2 and desired λ to generate an IMAP target. The network structure for the O_2 reference generator is made of one input layer, eight hidden layers and one output layer (a typical shallow neural network), while for the IMAP it has one input layer, three hidden layers and one output layer.

3.2 Training

The FIC GT-Power model was employed to build the dataset used to train the two networks constituting the reference generator. The dataset contained in total more than 9000 points. These points were obtained simulating through the GT-Power model a DoE over the entire engine map in which engine speed, injected fuel quantity and timing of the main pulse, rail pressure, EGR and VGT positions were varied. The totality of points have

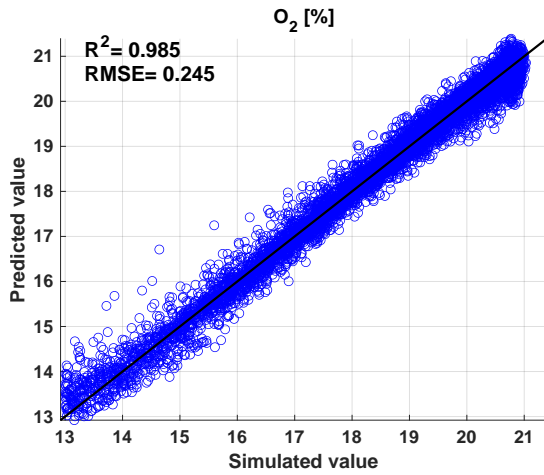

(a)

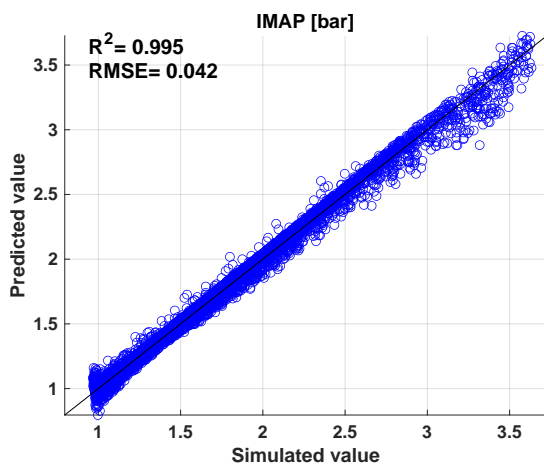

(b)

Fig. 3. Reference generator training correlation. O_2 (a) and IMAP (b).

been divided into three datasets, respectively for training, validation and testing aims. In order to find the networks that offered the best compromise between accuracy vs. complexity, the range from 1 to 30 hidden layers has been covered in training.

Furthermore, each hidden layer training was repeated ten times changing the initial value of the weights, after which the best training was selected. The selected network for the O_2 has eight hidden layers and performance indexes of $RMSE = 0.245\%$ and R^2 of 0.985. While for the IMAP a network with three hidden layers was sufficient to achieve metrics of $RMSE = 0.042$ bar and R^2 of 0.995. In Fig. 3 the correlation plots between GT-Power simulated and network predicted values are shown.

3.3 Steady state validation

A dataset made of 413 tests simulated in GT-Power that included a full engine map, an intake O_2 concentration tradeoff obtained through sweeps of EGR and VGT valve positions and a local DoE of SOI and pressure was used to analyze the steady-state behavior of the networks. Starting from the O_2 network, Fig. 4, it predicted the GT-Power values with a coefficient of determination of

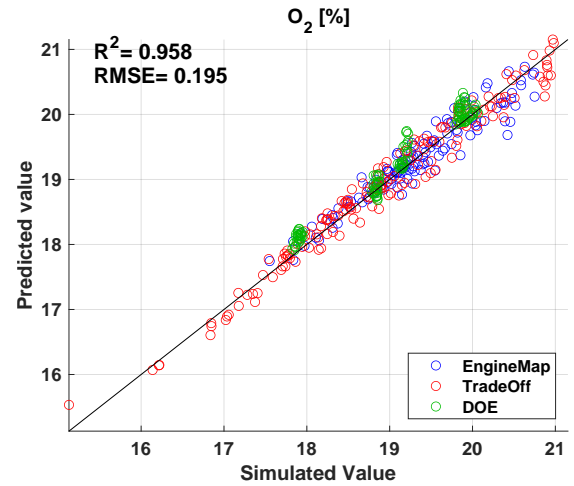

Fig. 4. O_2 reference generator steady state validation

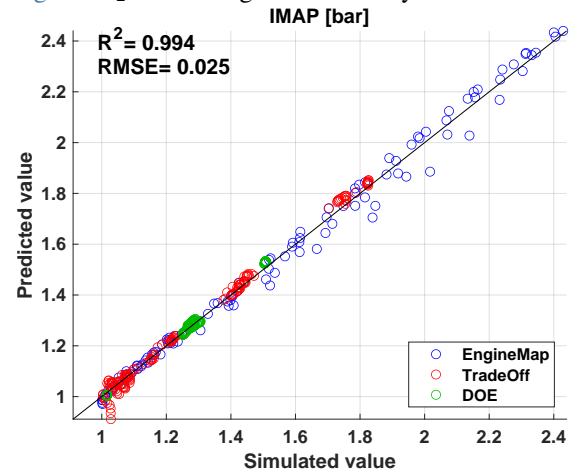

Fig. 5. IMAP reference generator steady state validation

0.958 and RMSE of 0.195%. Over the engine map the network returns a maximum relative error of -2.5% and +2% mainly from 2500 rpm to 3750 rpm. The IMAP network performance indexes of $RMSE = 0.025$ bar and $R^2 = 0.994$, Fig. 5, confirm the training results. Over the engine map the network suffers a maximum relative error of -5.5% and +2%. Particularly in the range between 1250 and 2000 rpm above ten bar of BMEP, the network expresses the highest error always in underestimation.

3.4 Transient simulation

Multiple tests have been conducted to verify network responses in transient conditions:

1. Slow varying load hat ramps at different speeds have been performed to verify the steady state results.
2. Hat ramps where speed and load vary together over the whole engine map.
3. A WHTC test to thoroughly assess networks behavior, including cutoff and idling.

In all those tests, the trained networks were fed with GT-Power values to compare their prediction of O_2 and IMAP over GT-Power simulated values. For the sake of brevity and clarity only a speed and load ramp and a portion of the WHTC cycle are presented in this paper.

In Fig. 6 the validation over a mixed speed and load hat

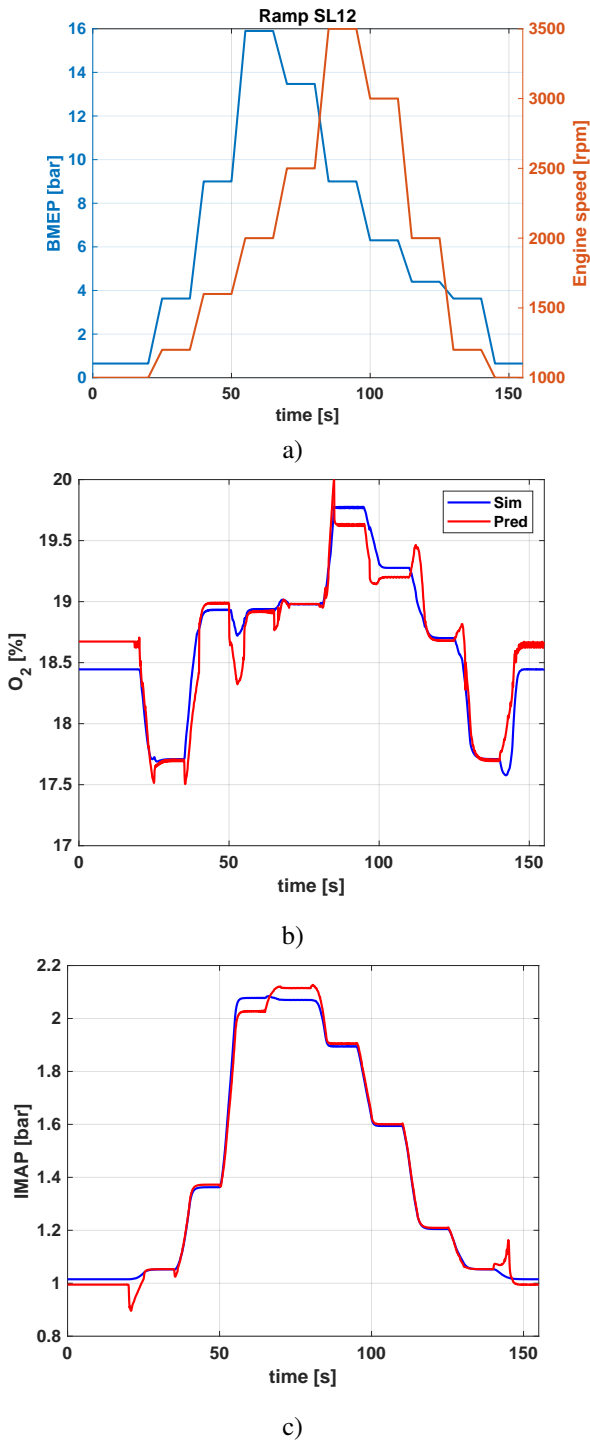

Fig. 6. Reference generator validation on a speed and load hat ramp. Ramps (a), O_2 (b) and IMAP (c).

ramp is shown. Looking at the intake O_2 , Fig. 6 b), the reference generator network, red line, does not deviate much from the GT-Power trace shown in blue. However, due to the GT-Power NOx model prediction variations, spikes appear during transients. By looking at the IMAP network, Fig. 6 c) red line, its correct behavior over the whole ramps is visible. Spikes appear only at the ramp tails corresponding to minimum speed and load.

The results of the WHTC test are reported in Fig. 7

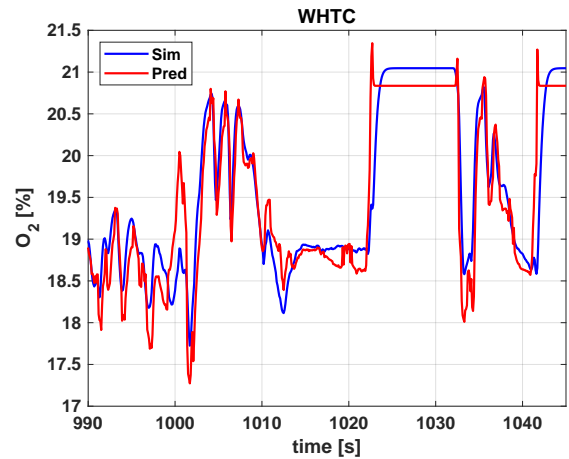

Fig. 7. O_2 reference generator validation over a portion of the WHTC profile

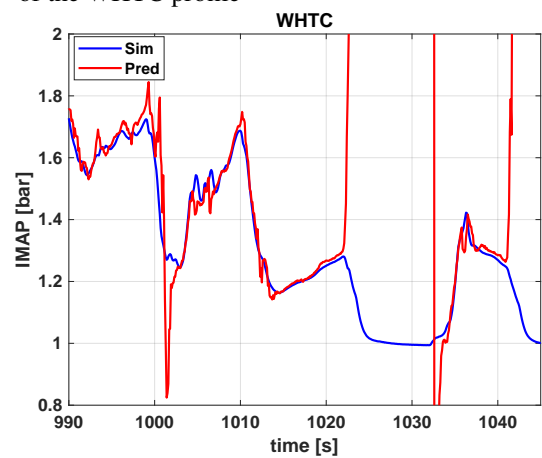

Fig. 8. IMAP reference generator validation over a portion of the WHTC profile

for the O_2 and in Fig. 8 for the IMAP. Both figures show the same section of the WHTC from time $t = 990$ s to time $t = 1045$ s. Intake manifold O_2 network, red line in Fig. 7, correctly reproduces the GT-Power trace shown in blue. The behavior is regular, even though undershoot tends to appear due to the GT-Power predicted NOx value. Errors are marginal and contained in a very small range. Fig. 8 shows the IMAP network performance (red line) over the GT-Power signal (blue line): overall, the network reproduces the GT-Power trace correctly. However, the vertical lines present in the figure immediately come to the eye. Those correspond to the engine entering fuel cutoff. Due to the very low, or null, value of injected fuel quantity and consequently very high lambda value, the network asks for high boost pressure values. This is a pure mathematical product, unfeasible and without meaning in the real engine.

Comparing the results of the two control systems working independently, papers [15] and [18], with the ones presented here, the presence of the coordinator removed oscillations that were present in O_2 control, thus improving stability of the system. Moreover, both the errors on the intake O_2 concentration and on the NOx emissions during the transients are reduced.

4. CONCLUSIONS

In this work an air path and combustion control systems coordinator based on neural networks has been presented. The coordinator sets the target for the two control systems, namely intake O_2 concentration and IMAP for the air path and BMEP and NOx for the combustion. The air path O_2 target is generated considering a desired NOx setpoint and the engine and combustion control states through engine speed and load, rail pressure and SOI. Instead, the IMAP target is generated given desired λ , intake O_2 and injected fuel. The same load and NOx targets used for the air path targets generation are also sent to the combustion control systems. To summarize, the networks performance are overall acceptable. During the analysis of the reference generator validation results emerged that some inputs have to be filtered out to avoid micro oscillations or in case of speed/load transients to avoid spikes due to their sharp derivatives. Furthermore, when the engine enters idling and cutoff, the coordinator and the control systems have to be switched off. From previous work, the lower limit of injected fuel $< 5 \text{ mg/stk}$ is a suitable threshold for this scope. In these conditions, it is better to rely on steady-state maps to avoid control system instability that could lead to permanent engine damage or, worse, endanger the driver's safety.

Future work will assess the feasibility of the approach with a reduced dataset and a mixed dataset containing both simulation and experimental data. This latter approach will allow exploiting the full potential of data-driven techniques by having a large dataset that came at low cost compared with one of the same size obtained through an experimental campaign.

REFERENCES

- [1] M. Baratta, R. Finesso, D. Misul and E. Spessa, "Comparison between internal and external egr performance on a heavy duty diesel engine by means of a refined 1D fluid-dynamic engine model," *SAE International Journal of Engines* Vol. 8, No. 5 (November 2015), pp. 1977-1992.
- [2] A. Ferrari, A. Mittica, P. Pizzo and Z. Jin, "Pid controller modelling and optimization in cr systems with standard and reduced accumulators," *International Journal of Automotive Technology*, vol. 19, no. 5, pp. 771-781, Oct 2018.
- [3] S. D'Ambrosio, F. Gaia, D. Iemmolo, A. Mancarella, N. Salamone, R. Vitolo and G. Hardy, "Performance and emission comparison between a conventional euro VI diesel engine and an optimized PCCI version and effect of EGR cooler fouling on PCCI combustion," in *WCX World Congress Experience*. SAE International, apr 2018.
- [4] R. Finesso, O. Marello, E. Spessa, Y. Yang and G. Hardy, "Model-Based Control of BMEP and NOx Emissions in a Euro VI 3.0L Diesel Engine," In *SAE Int. Journal of Engines*, vol. 10, 2017.
- [5] R. Finesso, O. Marello, D. Misul, Daniela E. Spessa, M. Violante, Y. Yang, G. Hardy and C. Maier, "Development and Assessment of Pressure-Based and Model-Based Techniques for the MFB50 Control of a Euro VI 3.0L Diesel Engine," In *SAE Int. Journal of Engines*, 2017.
- [6] G. Landsmann, M. Beasley, R. Cornwell, P. Fussey, R. King, A. Noble, T. Salamon and A. Truscott, "Reducing Diesel Emissions Dispersion by Coordinated Combustion Feedback Control," In *SAE 2006 World Congress & Exhibition*.
- [7] B. Shin, Y. Chi, M. Kim, P. Dickinson, et al., "Model Predictive Control of an Air Path System for Multi-Mode Operation in a Diesel Engine," *SAE Technical Paper* 2020-01-0269, 2020.
- [8] L. Yin, G. Turesson, P. Tunestål and R. Johansson, "Model Predictive Control of an Advanced Multiple Cylinder Engine With Partially Premixed Combustion Concept," In *IEEE/ASME Trans. on Mechatronics*, vol. 25, no. 2, pp. 804-814, April 2020.
- [9] S. A. Malan and L. Ventura, "Air-Path Control for a Prototype PCCI Diesel Engine," In *Proc. of 2018 26th Mediterranean Conference on Control and Automation*, pp. 843-848, 2018.
- [10] L. Ventura, R. Finesso, S. A. Malan, S. d'Ambrosio and A. Manelli, "Model-based design of closed loop controllers of the air-path in a heavy duty diesel engine," In *74th Congresso Nazionale ATI*. AIP Conference Proceedings, sep 2019.
- [11] T. Albin, D. Ritter, R. Zweigel and D. Abel, "Hybrid multi-objective MPC for fuel-efficient PCCI engine control," In. *Proc. of 2015 European Control Conference*.
- [12] X. Wei and L. del Re, "Gain Scheduled H_∞ Control for Air Path Systems of Diesel Engines Using LPV Techniques," In. *Control Systems Technology, IEEE Transactions on*, pp. 406-415, vol. 15, 2007.
- [13] I. Abidi, J. Bosche, A. E. Hajjaji and A. Aguilera-Gonzalez, "Fuzzy robust tracking control with pole placement for a Turbocharged diesel engine," In. *Proc. of 21st Mediterranean Conference on Control and Automation*, pp. 1417-1422, 2013.
- [14] J. Heywood, *Internal Combustion Engine Fundamentals 2E*, McGraw-Hill Education, 2018.
- [15] L. Ventura and S. A. Malan, "NLQR Control of High Pressure EGR in Diesel Engine," In. *Proc. of ICCAS 2020 20th International Conference on Control, Automation and Systems*.
- [16] S. A. Malan and L. Ventura, "A systematic procedure for engine air-path identification," In *International Journal of Mechanics and Control*, vol. 21, no. 1, pp. 127-138, 2020.
- [17] L. Eriksson, L. Nielsen, "Modeling and Control of Engines and Drivelines," *Wiley, Automotive series*.
- [18] S. A. Malan, L. Ventura and A. Manelli, "Cycle to cycle closed-loop combustion control through virtual sensor in a diesel engine," In. *Proc. of 2021 29th Mediterranean Conf. on Control and Automation*.