

A 80 km reach fully passive WDM-PON based on reflective ONUs

*Original*

A 80 km reach fully passive WDM-PON based on reflective ONUs / Presi, Marco; Proietti, Roberto; Contestabile, Giampiero; Ciaramella, Ernesto. - In: OPTICS EXPRESS. - ISSN 1094-4087. - 16:23(2008), pp. 19043-19048. [10.1364/OE.16.019043]

*Availability:*

This version is available at: 11583/2972461 since: 2022-10-19T14:48:17Z

*Publisher:*

Optical Society of America

*Published*

DOI:10.1364/OE.16.019043

*Terms of use:*

This article is made available under terms and conditions as specified in the corresponding bibliographic description in the repository

*Publisher copyright*

Optica Publishing Group (formely OSA) postprint versione editoriale con OAPA (OA Publishing Agreement)

© 2008 Optica Publishing Group. Users may use, reuse, and build upon the article, or use the article for text or data mining, so long as such uses are for non-commercial purposes and appropriate attribution is maintained. All other rights are reserved.

(Article begins on next page)

# A 80 km reach fully passive WDM-PON based on reflective ONUs

Marco Presi<sup>1\*</sup>, Roberto Proietti<sup>1</sup>, Kamau Prince<sup>1,2</sup>, Giampiero Contestabile<sup>1</sup>, and Ernesto Ciaramella<sup>1</sup>

<sup>1</sup>Scuola Superiore Sant'Anna, Via Moruzzi 1, 56124, Pisa

<sup>2</sup>DTU Fotonik, Department of Photonics Engineering, Technical University of Denmark, DK-2800, Kgs. Lyngby, Denmark

\*Corresponding author: [marco.presi@sssup.it](mailto:marco.presi@sssup.it)

**Abstract:** We propose a novel line coding combination (Inverse RZ coding in downlink and RZ in uplink) that extends the reach of WDM Passive Optical Networks based on Reflective SOAs with no in-line amplification. We achieved full downstream remodulation even when feeding the reflective SOA with power levels as low as  $-35$  dBm, thus increasing the system power budget. We experimentally assessed this scheme for a fully passive, full-duplex and symmetrical 1.25 Gb/s WDM-PON over a 80 km G.652 feeder.

© 2008 Optical Society of America

**OCIS codes:** (250.5980) Semiconductor optical amplifiers; (060.1155) All-optical networks; (060.0060) Fiber optics and optical communications.

---

## References and links

1. R. Davey, D. Payne, P. Barker, D. Nasset, S. Appathurai, T. Gilfedder, A. Rafael, and P. Healey, "Next Generation Extended Reach PON," in *OFC/NFOEC 2008*, pp. 1–25 (2008).
2. R. Kjaer, I. T. Monroy, L. K. Oxenlowe, P. Jeppesen, and B. Palsdottir, "Bi-directional 120 km Long-reach PON Link Based on Distributed Raman Amplification," *LEOS 2006* pp. 703–704 (2006).
3. K. Cho, Y. Takushima, K. Ryong, and Y. Chung, "Operating Wavelength Range of 1.25-Gb/s WDM PON Implemented by Using Uncooled RSOA's," *OFC/NFOEC 2008* (2008).
4. W. Lee, M. Park, S. Cho, J. Lee, C. Kim, G. Jeong, and B. Kim, "Bidirectional WDM-PON Based on Gain-Saturated Reflective Semiconductor Optical Amplifiers," *IEEE Photon. Technol. Lett.* **17**, 2460–2462 (2005).
5. N. Calabretta, M. Presi, R. Proietti, G. Contestabile, and E. Ciaramella, "A Bidirectional WDM/TDM-PON Using DPSK Downstream Signals and a Narrowband AWG," *IEEE Photon. Technol. Lett.* **19**, 1227–1229 (2007).
6. C. Arellano, C. Langer, and J. Prat, "Optical Network Units based on Semiconductor Optical Amplifiers in Single-Wavelength Single-Fiber Access Networks," *Breitbandversorgung in Deutschland-wie schaffen wir den Anschluss?* (2005).
7. X. Cheng, Y. Wang, T. Cheng, and C. Lu, "WDM-PON Architectures With a Single Shared Interferometric Filter for Carrier-Reuse Upstream Transmission," *J. Lightwave. Technol.* **25**, 3669–3677 (2007).
8. P. Healey, P. Townsend, C. Ford, L. Johnston, P. Townley, I. Lealman, L. Rivers, S. Perrin, and R. Moore, "Spectral slicing WDM-PON using wavelength-seeded reflective SOAs," *Electron. Lett.* **37**, 1181–1182 (2001).
9. E. Wong, K. Lee, and T. Anderson, "Directly-Modulated Self-Seeding Reflective SOAs as Colorless Transmitters for WDM Passive Optical Networks," *J. Lightwave Technol.* **10**, 67–74 (2007).
10. N. Deng, C. Chan, and L. Chen, "A centralized-light-source WDM access network utilizing inverse-RZ downstream signal with upstream data remodulation," *Opt. Fiber Technol.* **13**, 18–21 (2007).
11. H. Chung, B. Kim, H. Park, S. Chang, M. Chu, and K. Kim, "Effects of inverse-RZ and Manchester code on a wavelength re-used WDM-PON," *Proc. LEOS 2006* pp. 298–299 (2006).
12. C. Chow, Y. Liu, and C. Kwok, "Signal Remodulation with High Extinction Ratio 10-Gb/s DPSK signal for DWDM-PONs," *OFC/NFOEC 2008* (2008).

## 1. Introduction

Network operators are currently looking for valid solutions to deploy long reach Passive Optical Networks (PON) which allow to by-pass the so called Central Offices (COs). In this vision, the Optical Network Units (ONUs) are directly connected to the Optical Line Terminal (OLT) by optical links which may be up to 100km long. In already installed G-PON systems which are based on Time Division Multiplexed Access (TDMA), such reach extension is achieved by adding in-line amplifiers (also known as extenders) to existent infrastructures [1], which require to provide power supply points along the feeder line. Alternative Raman amplification was also proposed [2], which has the advantage of not requiring power supply along the line. However, both solutions imply an increase on the operational expenses. Future Wavelength Division Multiplexed PON (WDM-PON), where each ONU is served by a single wavelength, will allow to increase the network capacity and will simplify the network management as all the connections are point-to-point. In addition, the implementation of colourless ONUs will allow for centralised wavelength management, introducing further architectural simplification and cost savings. The availability of broadband multi-wavelength sources, athermal AWGs and reflective SOAs (R-SOAs), which provide for wide-band amplification and uncooled operations up to 1.25 Gb/s [3], opens the way to a practical deployment of WDM-PONs based on colourless reflective ONUs. However, in order to provide a full re-modulation of downstream traffic, R-SOAs must be operated in saturation regime [4], clearly posing power budget issues. To mitigate this drawback, several approaches were proposed: the use of downstream signals of reduced modulation-index [5], half-duplex transmissions (feeding the R-SOAs with CW light in the un-modulated slots) [6], carrier reuse [7], broadband seeding sources from the OLT [8] (which requires additional filtering at the ONU) and self-seeding [9] (which is very sensitive to power losses). Other interesting approaches are based on the use of optical line coding, namely Inverse RZ (IRZ) or Manchester (bi-phase) for the downstream and Non-Return-to-Zero (NRZ) coding for the upstream [10], [11]. By carrying non-zero energy in each bit (either “mark” and “space”) these line codes ease the upstream remodulation. However, as demonstrated in [11], this severely limits the upstream NRZ remodulation bandwidth, constraining to realize systems in which the uplink capacity is reduced in respect to the downlink. Moreover all demonstrations of PONs exploiting IRZ modulation in downlink rely on the use of Mach-Zender modulators (MZM) at the ONUs, which is not a practical option, as the MZM is polarisation dependent; as an alternative, an electro-absorption modulator (EAM) is polarisation independent, but it impacts the PON power budget, because of high insertion loss. Therefore, an approach based on R-SOAs operated far from the saturation would be strongly preferred.

In this letter, we introduce a novel use of the IRZ coding in a single feeder reflective bidi-

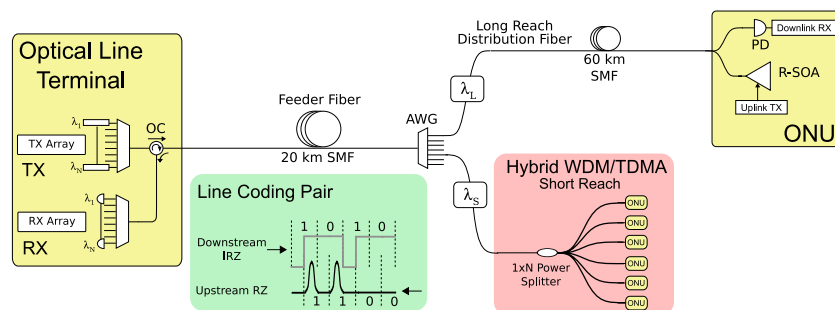

Fig. 1. WDM-PON architecture with IRZ/RZ coding. The green inset shows the proposed remodulation principle.

rectional WDM-PON allowing to overcome most of the limitation indicated above. By using 50% IRZ in downstream and RZ coding in upstream signal we not only achieve symmetrical bandwidth, but also operate the R-SOAs far from the saturation regime, thus relaxing the constraints on the ONU's received power. Using this technique we obtained remodulation with full downstream erasure by seeding a R-SOA with power levels as low as  $-35$  dBm average power over an extended reach of 80km, with no in-line amplification. The PON power budget is then improved without increasing the operational expenses associated with in-line amplification. This technique may be also used to increase the power-splitting-ratio in hybrid WDM/TDMA-PONs (allowing to serve more than one user on a single wavelength); optionally those two solutions may be implemented simultaneously in the same WDM-PON on different wavelengths as shown in Fig. 1.

## 2. Operating principle and experimental setup

The architecture is shown in Fig. 1. It is a WDM-PON where an AWG acts as a remote splitter. The downstream signal is coded 50% IRZ (inset of Fig. 1); the key point is to interleave the RZ upstream transmission by half-bit in respect to the incoming IRZ pattern, so that the RZ modulation is performed over a CW slot. When the ONU receives a logical "1" (a dark pulse) it can either suppress the dark pulse high rail (to re-transmit a "0") or amplify it (to re-transmit a "1"); otherwise, if a logical "0" (a constant power bit) is received, the R-SOA will carve a pulse on it (to re-transmit a "1") or will suppress the whole bit (to re-transmit a "0"). There are therefore four 2-bit combinations, which are illustrated in inset of Fig. 1. The main requirement is that the upstream signal is properly synchronised with the downstream at each ONU; however this operation should not introduce great issues since a local clock must be always available at the ONU receiver. The synchronisation can be achieved by using a proper (fixed) optical delay line (ODL). Furthermore, this synchronisation is not dependent on the correct reception of received downlink pattern, as it is required in [12] to erase and remodulate DPSK traffic. This process does not require any extinction ratio limitation on the downstream signal, neither it requires the R-SOA to be saturated because the signal is always RZ remodulated at times when there is a CW light.

The experimental setup is illustrated in Fig. 2. We tested the architecture on a single wavelength. At the OLT the downstream IRZ pattern was obtained by modulating an external cavity laser operating at 1542nm with a Mach-Zender Intensity modulator (MZ). The MZM was driven by an electrical PRBS,  $2^7 - 1$  bits long encoded in an IRZ pattern at 1.25 Gb/s. Although we chose a MZM, also other transmitters may be considered for this application (i.e. directly-modulated DFBs). However, in the following we will focus on reach extension achievable with our proposed line-coding rather than on the transmitter implementation. The IRZ coding was obtained by setting the clock frequency of the pattern generator to 2.5 GHz, and creating a custom  $2^7 - 1$  PRBS pattern, where a sequence of "01" was inserted to transmit a mark symbol, and a sequence "11" was used to transmit a space symbol. The PRBS length was chosen according to the 8B10B coding, typical of Gigabit Ethernet. The OLT transmitter comprised a Variable Optical Attenuator (VOA), which allowed to set the downstream launch power in a range from  $-7$  and 3 dBm. By doing this, we set the power received at the ONU between  $-25$  and  $-35$  dBm. The launch power was thus minimized in order to minimize the Rayleigh back-scattering, which introduced a transmission power penalty in the upstream signal (as it will be discussed in sec. 3). After an optical circulator, with 1 dB insertion loss (IL), the signal was launched over 80km of Single Mode Fiber (SMF) with 17dB total IL. The AWG was emulated by means of a 0.8nm tunable optical filter (OTF) with 3dB IL. This filter rejected the ASE noise from the R-SOA. Adding fiber connector losses, we thus eventually considered about 24dB of total link losses. The ONU comprised a 3dB coupler, a receiver and a R-SOA. The

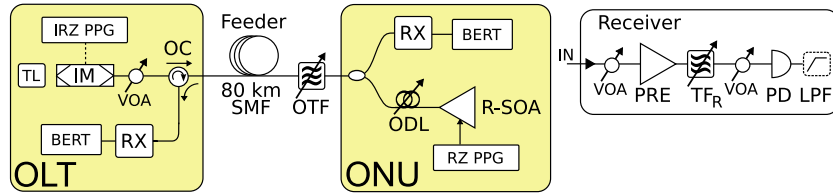

Fig. 2. Experimental Setup: TL: Tunable Laser; IM: Intensity Modulator; PPG: Pulse Pattern Generator; VOA: Variable Optical Attenuator; OC: Optical Circulator; SMF: Single Mode Fiber; ODL: Optical Delay Line; OTF: Tunable Filter; PRE: Preamplifier (EDFA); PD: Photodiode; LPF: 4<sup>th</sup>-order Bessel Low Pass Filter

R-SOA was a commercially available device (CIP SOA-RL-OEC-1550) with 1.5 GHz modulation bandwidth, 24 dB small signal gain at 50 mA bias current, 2 dBm output saturation power, 1 dB polarisation dependent gain and a 8 dB noise figure. No polarization controller was inserted in front of the R-SOA. The R-SOA was biased at 70 mA (in order to provide an higher gain and balancing the line loss) and driven with a 7 V peak-to-peak RZ encoded signal (a  $2^7 - 1$  long PRBS, 1.25 Gb/s as for the downstream). An ODL (5 dB IL) was used to ensure the proper synchronisation between downstream and upstream traffic. In a real deployment, this synchronisation should be performed electronically. We thus might consider its 5 dB loss as an additional operating margin for a real deployment. The receiver used to characterise the system (both at the ONU and the OLT) was optically pre-amplified (see inset of Fig. 2). The optical preamplifier was a double stage Erbium Doped Fiber Amplifier (EDFA) followed by an optical filter of 0.2 nm bandwidth and by a variable optical attenuator, used to keep a constant power of  $-6$  dBm over a 10 GHz PIN detector. We also implemented a post-detection low-pass filter (Bessel, 4<sup>th</sup>-order) with 1.87 GHz bandwidth. This pre-amplified receiver allowed for Bit-Error-Ratio (BER) measurement with single channel input optical power as low as  $-50$  dBm. In a real environment, an avalanche photodiode (APD) would be preferred, at least at the ONU side. At the headend the pre-amplifier may be shared by more than one wavelength, and a narrow bandwidth AWG (available on the market) may be used in place of the 0.2 nm filter. We note that while the pattern generator (both at the OLT and the ONU) was driven by a 2.5 GHz clock, the BER tester was driven by a clock corresponding to the bit-rate (1.25 Gb/s), obtained by a clock divider thus performing a correct BER measurement.

### 3. Results and discussion

We start the analysis of the system performance by examining the eye diagrams of both the downlink and uplink signals, which are reported in Fig. 3. The downstream eye-diagrams are reported back-to-back (Fig. 3-a) and after the transmission with the R-SOA off (Fig. 3-b). As can be seen, the eye-diagram of the downstream signal is only slightly affected by the propagation. When the upstream signal is turned on (Fig. 3-c), the downstream eye-diagram shows an incremented noise on the “space” level. This is due to the Rayleigh’s back-scattering generated by the upstream signal at the same wavelength. The slight power penalty induced by this effect is discussed later in this section. The upstream eye-diagrams reported in Fig. 3 are recorded at the RSOA output, and refer to three seeding power levels:  $-25$  dBm (inset d),  $-30$  dBm (inset e) and  $-35$  dBm (inset f). We observed a slight patterning effect that was due both to the limited electro-optic modulation bandwidth of the R-SOA and to the remodulation process: when the R-SOA is remodulating a “0” or a “1” the carved pulses have slightly different shapes. Yet, the eye-diagram still was wide open for all seeding levels. All this patterning was not dependent on the seeding power. We observed an increased noise contribution at decreasing seeding

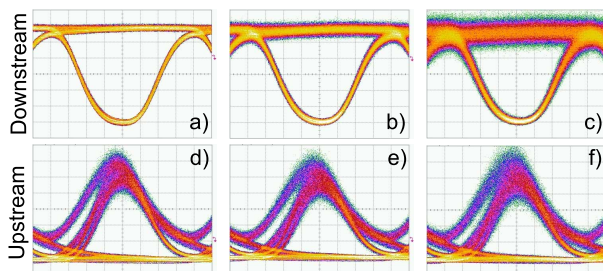

Fig. 3. Eye-diagrams of the down/up-stream channels. Downstream: a) back-to-back; b) after 80km SMF; c) after 80km SMF and RSOA on. Upstream back-to-back for three seeding power levels: d)  $-25$  dBm; e)  $-30$  dBm; f)  $-35$  dBm. All eye-diagrams have been recorded with a 1.87 GHz electrical post-detection filter on a time scale of 100 ps/div.

power. The electro-optical bandwidth limitation of the R-SOA limited the duty-cycle of the remodulated signal to a value close to 66% (upstream electrical signal had a 50% duty-cycle).

The PON performance was characterized by BER measurements, reported in Fig. 4. The optical power reported in Fig. 4 is measured at the preamplifier input (after the VOA). The downstream signal (Fig. 4-a) had about 1.5 dB of power penalty after the 80 km SMF transmission. This penalty was due partially to the lack of a clock recovery circuit at the ONU receiver, and partially to the Rayleigh scattering generated inside the feeder by the upstream signal: indeed, as the R-SOA was disconnected, the downlink power penalty was reduced by about 0.5 dB. The R-SOA induced penalty was observed only when the R-SOA was highly saturated (i.e. when it was fed with optical power exceeding  $-15$  dBm) thus providing around 0 dBm of remodulated power and thus maximising the Rayleigh back-reflections. The upstream BER performance was also measured, and the obtained BER curves are reported in Fig. 4. We noted that the back-to-back upstream sensitivity performs better than the transmitted downstream by about 6 dB. This is consistent with the fact that the IRZ modulation format has a theoretical penalty of about 5 dB in respect to the RZ format. The transmission power penalty of the upstream signal is essentially determined by the RSOA seeding power. We report here three cases ( $-25$ ,  $-30$ , and  $-35$  dBm seeding power levels) where the RSOA was not saturated. In the first two cases, we obtained almost similar performance: the upstream transmission power penalty was between 4.5 and 5.5 dB for  $-25$  and  $-30$  dBm seeding power levels, respectively. In those two cases, the power penalty was mostly due to the Rayleigh back-scattering, which limited the Optical Signal to Noise Ratio (OSNR) of the upstream signal at the OLT to 15 dB. This OSNR was measured at an Optical Spectrum Analyser (OSA). For R-SOA seeding power levels lower than  $-30$  dBm we noted a decreased performance. Indeed, in this condition the total R-SOA ASE noise over the OTF bandwidth was not negligible in respect of the remodulated signal power. This out-band ASE noise slightly affected the back-to-back upstream sensitivity (1 dB power penalty at  $-35$  dBm seeding power compared to the case of  $-25$  and  $-30$  dBm). Conversely, the interplay of chromatic dispersion and filtered ASE noise introduced a transmission power penalty of about 7 dB and a tendency to BER floor (white and black circles in Fig. 4-b).

From these results, assuming a 70 – 30% coupler at the ONU input, the ONU should be fed with input optical power levels in a range between  $-23$  and  $-28$  dBm. By using an optically preamplified receiver we obtained a downlink sensitivity of  $-43$  dBm, by far lower than the required power range at the ONU: however, as mentioned previously, an APD should be preferred at the ONU. Commercial APD provide  $-35$  dBm sensitivity at 2.5 Gb/s, which is still compatible with the required power range. We can thus see that the results reported here are not strictly related to the optical preamplifier at the ONU. The uplink signal is preamplified by the



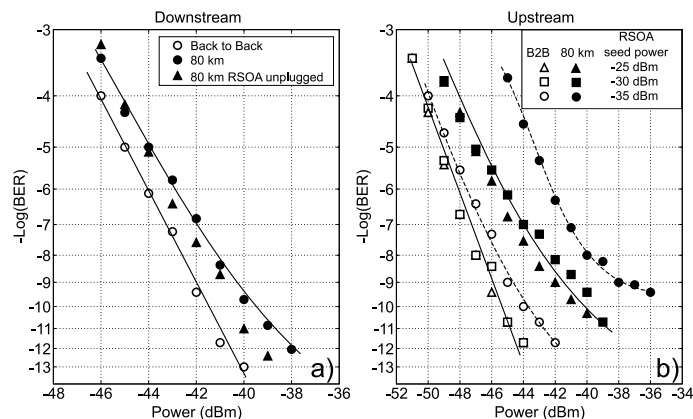

Fig. 4. BER of downstream (a) and upstream (b). White symbols refer to back-to-back conditions. Black ones indicate BER after transmission over the 80 km feeder. For the upstream case, the BER measurements are reported for three different RSOA seeding power levels (-25,-30,-35 dBm)

ONU itself: in this characterization, we chose a feeder fiber length such that total link losses were exactly compensated by the ONU gain: in this regime, the receivers at the OLT and at the ONU should have the same sensitivity. However, while the downlink signal performance was not limited by OSNR penalty, the uplink performance was OSNR limited, especially when the R-SOA seeding power was below  $-30$  dBm. The link margin of about 30 dB used here to achieve a reach extension in WDM-PON, may be used also to realize hybrid WDM-TDMA PON. Of course in this last case the reach should be reduced to compensate for the introduction of power splitting; the splitting ratio would be dependent on the feeder length. An upgrade of the operating bit-rate of the proposed architecture may be achieved by using higher E/O bandwidth remodulators (such reflective electro-absorption modulators integrated with SOAs); however, in this case the system margins should be adapted to the characteristics of the particular remodulator chosen.

#### 4. Conclusions

We reported error-free full-duplex bidirectional 1.25 Gb/s transmission in a fully passive 80 km long reach PON based on reflective SOAs. This result extends by about 60 km the reach of fully passive PON based on R-SOAs [4]. It was achieved by the use of a novel line coding pair, Inverse-RZ in downstream and RZ in the upstream, which allowed to strongly relax the power budget constraints. By this particular line coding pair we operated a reflective SOA in the linear regime with input power as low as  $-35$  dBm, so that the system reach was mainly limited by the R-SOA noise figure (posing a lower limit on the R-SOA seeding power) and gain (which posed a limit on the upstream launch power). This scheme is not based on any filtering at the ONU, and it is compatible with already installed WDM-PONs. The use of IRZ/RZ may be implemented to allow for longer reaches and/or to implement hybrid WDM-TDMA PONs on selected wavelengths, thus providing an high degree of flexibility in design and deployment of next generation WDM-PONs.

#### Acknowledgments

This work has been supported in part by Ericsson under a grant. K. Prince acknowledges an international Ph.D. scholarship from the Danish Agency for Science, Technology & Innovation.