

Artery in Microgravity (AIM): Assembly, integration, and testing for a student payload for the ISS

Original

Artery in Microgravity (AIM): Assembly, integration, and testing for a student payload for the ISS / García Mozos, Luis; Saroya, Devonjit; Roelvink, Yannick; Santos D'Amore, Naël dos; Gabetti, Stefano; Galván Lobo, Jorge; Lobo, Catarina; Joshi, Mrunmayi; Penedo, Guilherme; Rodríguez Encinas, Jorge Alberto; Torta, Elena; Lee, Seungah; Laulan-Souilhac, Baptiste; Mouchel, Roman; Lustro, Sacha; Butin, Alexis; Campos, Mário Gabriel; Passoni, Laura; Avallone, Luigi; Alex, Abin. - ELETTRONICO. - (2022), pp. 557-562. ((Intervento presentato al convegno 4th Symposium on Space Educational Activities (SSEA) tenutosi a Barcellona (Spain) nel 27-29 April 2022 [10.5821/conference-9788419184405.097]

This version is available at: 11583/2971025 since: 2022-09-07T09:11:55Z

Publisher:

European Space Agency

Published

DOI:10.5821/conference-9788419184405.097

Terms of use:

openAccess

This article is made available under terms and conditions as specified in the corresponding bibliographic description in the repository

Publisher copyright

(Article begins on next page)

Artery in Microgravity (AIM): Assembly, Integration, and Testing for a Student Payload for the ISS

Luis García Mozos¹, Devonjit Saroya², Yannick Roelvink², Naël Dos Santos D'Amore², Stefano Gabetti³, Jorge Galván Lobo², Catarina Lobo², Mrunmayi Josh², Guilherme Penedo², Jorge Alberto Rodríguez Encinas², Elena Torta³, Seungah Lee², Baptiste Laulan--Souilhac², Roman Mouche², Sacha Lustro², Alexis Butin², Mário Gabriel Campos², Laura Passon², Luigi Avallone², Abin Alex²

Abstract

The Artery in Microgravity (AIM) project was the first experiment to be selected for the “Orbit Your Thesis!” programme of the European Space Agency Academy. It is a 2U cube experiment that will be operated in the International Commercial Experiment (ICE) Cubes facility onboard the International Space Station. The experiment is expected to be launched on SpaceX-25 in mid-2022. The project is being developed by an international group of students from ISAE-SUPAERO and Politecnico di Torino.

The objective of the experiment is to study haemodynamics in the space environment applied to coronary heart disease. The outcomes of this testbench will contribute to understanding the effects of radiation and microgravity on the circulatory system of an astronaut, specifically the behaviour in long-term human spaceflight. It will also help to ascertain the feasibility of individuals suffering from this kind of disease going to space someday. The cornerstones of the experiment are two models of 3D-printed artificial arteries, in stenotic and stented conditions respectively. Blood-mimicking fluid composed of water and glycerol is circulated through the arteries in a closed hydraulic loop, and a red dye is injected for flow visualisation. Drops of pressure and image analysis of the flow will be studied with the corresponding sensors and camera. The pH of the fluid will also be monitored to assess the effect of augmented radiation levels on the release of particles from the metallic stent.

Some delays were experienced in the project due to the COVID-19 pandemic and to implement design improvements. Improvements were made to several aspects of the design including mechanics (e.g. remanufacturing the reservoir with surface treatment against corrosion, leak prevention measures), software (e.g. upgrading to Odroid-C4 and migrating the code to Python), and electronics (e.g. several iterations of the interface PCB design). This iterative process of identifying areas of concern and designing and implementing solutions has resulted in many lessons learned.

The paper will outline in detail Phase D – Qualification and Production of the AIM experiment cube, with special insight on the implementation of the improvements. Previously, at the Symposium on Space Educational Activities in 2019 in Leicester, the initial phases of the design and development of the cube were presented. This year, the final flight model and the results of validation testing before launching on SpaceX-25 are presented. Lessons learned throughout the course of the project are also highlighted for students embarking on their own space-related educational activities.

Keywords

AIT, haemodynamics, leak prevention, microgravity, Orbit Your Thesis!

¹ Corresponding author: ISAE-SUPAERO, France, luis_garcia_mozos@hotmail.com

² ISAE-SUPAERO, France

³ Politecnico di Torino, Italy

Acronyms/Abbreviations

<i>AIM</i>	<i>Artery in Microgravity</i>
<i>AIT</i>	<i>Assembly, Integration, and Testing</i>
<i>BMF</i>	<i>Blood Mimicking Fluid</i>
<i>COTS</i>	<i>Commercial Off-the-Shelf</i>
<i>ESA</i>	<i>European Space Agency</i>
<i>I2C</i>	<i>Inter-Integrated Circuit</i>
<i>ICE</i>	<i>International Commercial Experiment</i>
<i>ICMCC</i>	<i>ICE Cubes Mission Control Centre</i>
<i>ISS</i>	<i>International Space Station</i>
<i>LED</i>	<i>Light Emitting Diode</i>
<i>NASA</i>	<i>National Aeronautics and Space Administration</i>
<i>OBC</i>	<i>On-Board Computer</i>
<i>PCB</i>	<i>Printed Circuit Board</i>
<i>PWM</i>	<i>Pulse-Width Modulation</i>
<i>REST API</i>	<i>Representational State Transfer Application Programming Interface</i>
<i>VPN</i>	<i>Virtual Private Network</i>

1. Introduction

The Artery in Microgravity (AIM) project is a 2U cube experiment that will be housed within the International Commercial Experiment (ICE) Cubes facility by Space Applications Services in the Columbus module of the International Space Station (ISS). The cube has been developed by an international and interdisciplinary group of students from ISAE-SUPAERO in Toulouse, France and Politecnico di Torino in Italy. The project was selected for the 'Orbit Your Thesis!' Programme of the European Space Agency (ESA) Academy.

Space Applications Services' ICE Cubes Service provides access to the ISS for scientific research, technological demonstrators and for educational purposes that require microgravity conditions and radiation exposure in a pressurised volume. The ICE Cubes Facility is a sliding platform permanently installed on-board the ISS that accommodates "plug-and-play" experiment cubes, hosting the functional interfaces to the ISS infrastructure [1].

An experiment that investigates haemodynamics in coronary arteries was thus developed to investigate how the altered vascular flow in microgravity may exacerbate or diminish atherosclerotic lesions in coronary arteries and thereby determine how the risk to

astronauts of myocardial infarction is affected by space travel. In addition, the experiment makes use of the radiation environment on-board the ISS to investigate if implantable devices, such as coronary stents, are at risk of re-stenosis due to the release of metallic ions stimulated by radiation exposure [1].

2. Summary of Project Timeline

The AIM project was selected by ESA Academy for the "Orbit Your Thesis!" programme in October 2018. Since then, almost 40 students have collaborated on the project over the different generations of teams. The experiment was expected to launch on the SpaceX-20 mission in March 2020; however, due to delays because of the COVID-19 pandemic and time taken to implement design changes, the expected launch has been pushed back to the SpaceX-25 mission in mid-2022.

Phase D (Qualification and Production) [2], which this paper describes in detail, started in mid-2021 and will conclude with the launch of the AIM cube experiment to the ISS in mid-2022. The phase includes assembly, integration, and testing (AIT) of the cube, as well as launching to the ISS. In March 2022, the Flight Acceptance Review was passed, receiving permission to launch at the next opportunity. Phase E (Operations) is expected to last between one and four months in orbit [2].

2.1. Testing campaign overview

The main goal of Phase D was to conduct a series of tests to ensure the compliance of the experiment cube with all the applicable requirements in terms of safety and functionality. This section depicts the different tests that were carried out to this end.

2.1.1. Electromagnetic Compatibility Test

Objectives: To verify that the cube hardware complies with the ICE Cubes Facility's electromagnetic interference requirements.

Facilities: INSA's Laboratoire d'Analyse et d'Architecture des Systèmes IT and Electronics Department from 20/07/2021 to 22/07/2021.

Approach: Measuring the electrical field emissions, magnetic field emissions, and conducted emissions and verifying their conformance with the applicable requirements.

2.1.2. Vacuum Test

Objectives: To guarantee the structural integrity of the cube and the absence of leaks in case of an unforeseen depressurization during launch or once installed on-board the ISS.

Facilities: ISAE-SUPAERO Space Vacuum Chamber (Building 38) on 24/11/2021.

Approach: Place the unpowered cube in the vacuum chamber and de-pressurize to below 1 mbar for 5 minutes. Re-pressurize and carry out a full visual inspection and a functional check.

2.1.3. Full Functional Test

Objectives: To check the integral functionality and operability of the cube to accomplish the mission requirements on-board the ISS.

Facilities: ESEC-GALAXIA's CubeSat Support Facility on 19/01/2022.

Approach: General check of all functional features of the cube in-flight experiment conditions: power-up and connection, pressure and pH sensors operability, pumps functioning with video recording of dye injection.

2.1.4. Audible Noise Test

Objectives: To verify that the total unweighted Sound Pressure Level generated by the cube in the noisiest functioning conditions does not exceed the Columbus module's limits.

Facilities: ISAE-SUPAERO's DCAS Electronics Lab on 11/01/2022.

Approach: Setting the cube in its noisiest operating scenario (pump running at 100%) and measuring the noise levels at a distance of 16 centimetres from the six sides of the cube.

2.1.5. Vibration Test

Objectives: To guarantee that the structural and functional integrity of the cube will withstand the random vibration loads expected during launch.

Facilities: ESEC-GALAXIA's CubeSat Support Facility from 17/01/2022 to 19/01/2022.

Approach: Perform an initial visual inspection and functional test. Then, carry out a resonance search shaking along one principal axis of the cube. Next, apply a random vibration load of 2.09 g_{rms} for 1 minute, and then repeat the resonance search. Repeat for the three principal axes. Finally, perform a second full functional test and full visual inspection.

2.1.6. Interface Test

Objectives: Space Applications Services to verify the compliance of the AIM cube with all the applicable hardware and software requirements for its safe installation on the ICE Cubes Facility on-board the ISS.

Facilities: Space Applications Services clean room and ICE Cubes Mission Control Centre (ICMCC) on 24/01/2022 and 25/01/2022.

Approach: Conducted by Space Applications Services to sequentially verify physical and electrical features, mechanical and electrical interface with ICE Cubes Facility, and software communication interface with the ICMCC.

3. AIM Experiment Cube Overview

The design of the cube can be divided into three main areas of work: mechanics (including the fluidics loop), electronics, and software. This section will provide a broad overview of the design solutions applied for each of these areas.

3.1. Mechanics and fluidics sub-system

The mechanical design of the AIM cube is roughly based on a 2U form factor. The only interface with the exterior is a DB13W3P connector used to receive power and data communication from the ICE Cubes Facility on-board the ISS. Figure 1 presents an overview of the fluidics sub-system and its associated instrumentation, and Figure 2 is a picture of the AIM experiment cube.

An internal frame is used to support all internal components including sensors, pumps, and the two models of artificial arteries that constitute the core of the science experiment. These arteries were manufactured by Elastrat, a company specialised in making silicone phantoms that mimic the mechanical properties of real arteries. The internal frame is attached to the external structure and to the aluminium reservoir. The reservoir contains a large fraction of the Blood Mimicking Fluid (BMF) that circulates through the fluidics loop. The reservoir is closed by a movable piston that allows the fluidics loop to be filled correctly. It is also effective for removal of trapped air, which is critical for the functioning of the system.

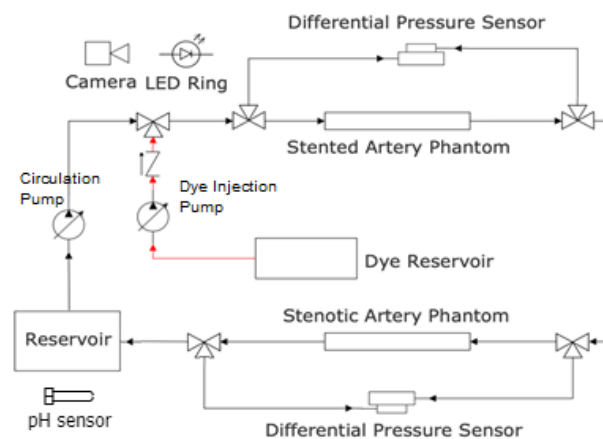

Figure 1. Fluidics system and instrumentation

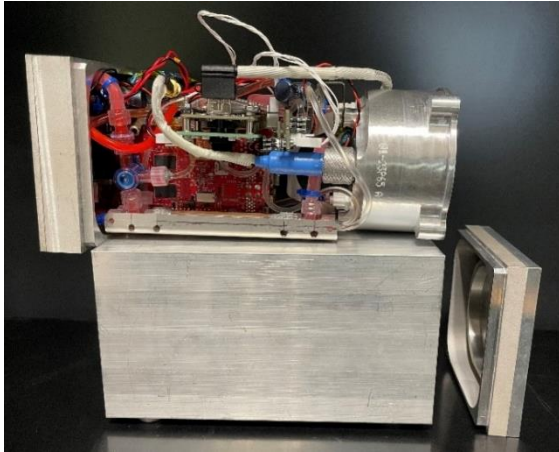

Figure 2. AIM experiment cube hardware

This BMF is made of a mixture of glycerol and distilled water to reach a similar viscosity and density to that of real blood. BMF is extracted from the reservoir thanks to a micropump and circulated through the two arteries, the first having a stent and the second one being in stenotic condition. Fluid then returns to the reservoir to continue circulating in closed loop. pH is also monitored in the reservoir to observe possible fluctuations due to the release of ions from the metallic stent in microgravity.

In addition, four smaller tubes feed the differential pressure sensors that measure, respectively, the pressure drops along the stented artery and along the stenotic artery. Finally, an isolated branch of the fluidics system consists of a pouch of red dye diluted in glycerol and water that gets injected into the main loop right before the artery models. The injection is done drop by drop thanks to a second micropump. This allows the streamlines of the dye drops flowing through the arteries to be observed thanks to a camera located above them.

3.2. Electronics sub-system

To accomplish the scientific purpose, the assembly of the instruments is achieved with three different interface printed circuit boards (PCB): main, LEDs, and pressure sensors. These are used to operate the sensors, pumps, and camera from the on-board computer (OBC) of the AIM cube. Figure 3 shows the final electrical implementation link diagram. The boards were subject to several iterations during the project, optimized in consecutive phases:

1. Basic electrical conception: a first diagram was drawn in cooperation with the scientific and mechanical teams.

2. Components' selection: Commercial off-the-shelf (COTS) components were selected to comply with the requirements of the experiment and standards from ESA and partners.
3. Proof-of-concept: A basic proof-of-concept was manufactured to validate the functionalities of the electronics.
4. Validation: Extensive validation was performed, considering functionality, power consumption, and electromagnetic interferences. Once success was achieved, the layout of the boards was fixed.
5. Flight model: This model was developed with the final layout of the board and mounted onto the AIM cube for flight.

3.3. Software sub-system

In order to run the experiments required for the scientific purpose of the experiment cube, the Odroid-C4 OBC had to be configured and operated accordingly. This was achieved by implementing software applications on-board and on-ground.

3.3.1. On-board software application

The on-board module operates several subsystems within the Ubuntu 20.04 Minimal Operating System that is running on the on-board computer. These are:

- Command handling using a REST API service, which receives telecommands sent from the on-ground station and forwards the command to the corresponding on-board subsystems.
- Data acquisition modules, which use hardware-based Inter-Integrated Circuit (I2C) communication to fetch data from the pressure and pH sensors.

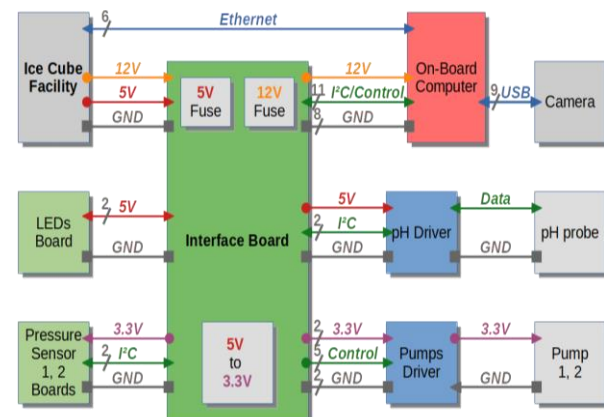

Figure 3. Electrical implementation link diagram

- On-board database using Docker PostgreSQL container, which is used to store sensor data and operational logs.
- Visual data (images and videos) retrieval via a custom-made camera module. The images are saved on the SD card of the Odroid OBC and synchronized to an on-ground storage location.
- Hardware-based Pulse-Width Modulation (PWM) modules, which control the actuators (LEDs and pumps) used to run the experiments

All the modules, with the exception of the database, are coded using Python 3.

3.3.2. *On-ground software application*

Meanwhile, the on-ground module monitors and sends operational commands from a Grafana dashboard. In addition, it runs an on-ground database, which automatically collects data from and synchronizes with the on-board database. The camera data is automatically synchronized with the ground using a separate synchronization module.

3.3.3. *Communication architecture*

The machine hosting the on-ground application is connected to the on-board application using a Virtual Private Network (VPN), hosted on a local server. The VPN then connects to the ICMCC, which forwards the connection to the cube on-board the ISS.

4. **Main Challenges and Lessons Learned**

Throughout the final development of the cube, several issues were tackled by the team, introducing substantial design improvements that resulted in valuable lessons learned.

4.1. *Mechanics and fluidics sub-system*

Qualifying an experiment full of liquids to comply with all the safety requirements needed for its launch and operation on-board the ISS has turned out to be an enormous challenge for this student project.

The first problem addressed was the appearance of corrosion in the reservoir. After more than one year of the system being closed, and not correctly cleaned from fluids during the stop of the project for COVID-19 lockdowns, the piston was found stuck in the reservoir due to corrosion. The whole reservoir and piston, specifically built for this project, had to be re-manufactured in June 2021. To avoid the problem from reoccurring, it was then

manufactured in Aluminium EN-AW 6061 surface treated with Surtec 650 [3]. Strict cleaning procedures after every re-filling were also introduced.

Afterwards, the main challenge faced was the spontaneous formation of bubbles inside the fluidics loop, that appeared after some days of the fluids sitting inside the closed loop. After deep investigations and with the input of experts from ESA, the following actions were carried out to minimise the formation of bubbles:

- Degassing of the BMF and dye in vacuum, at about 11 mbar, to get rid of dissolved gasses in the fluids.
- Replacement of part of the tubing materials from silicone to Tygon S3 E-3603 [4], to reduce the gas permeability across the walls of the tubes.
- Granting of a late cargo delivery opportunity by ESA's Payload Integration Management, allowing the shipment of the cube to the Launch Base two weeks before launch. This allows for the last refilling to be done as late as possible prior to launch.

In addition, a major point of concern was improving the sealing of the fluidics system in all interfaces. This was also motivated by leakage issues encountered during the vacuum test. The following enhancements were introduced to this end:

- Reinforcement of the sealing of the dye bag, after a failure during the first vacuum test due to fatigue cycling.
- Gluing of the pressure sensor tubes to the sensors with Epoxy glue.
- Reinforcement of all joints between tubes and fluidics components with o-rings for threaded joints and with silicone sealant.
- Application of high vacuum grease on the reservoir piston o-ring.

4.2. *Electronics sub-system*

Given that the development, integration, and validation of the different models of PCBs were done in a very short time, several issues were encountered, and solutions proposed.

To this end, the iteration on PCBs shall be minimized to reduce costs and waiting time. In addition, it is essential to keep good communication between sub-teams to ensure the coordination with mechanical and software interfaces to avoid delays and cost overruns.

In any case, the development of electronics for scientific payloads is getting easier and more accessible also for students in recent years, with an increasingly broader panel of COTS components offered at an affordable price.

4.3. Software sub-system

Throughout the software development process, there were several issues that needed to be corrected, with the most important ones listed.

Firstly, due to compatibility issues between an open-source library used within the software and the hardware, the PWM and I2C peripherals could not be controlled from the software itself but had to be controlled from the Operating System directly.

Also, in the original versions of the software implementation, the on-board software was developed using the C programming language. However, due to compatibility and accessibility issues, combined with the sheer operational difficulty of the C language for team members that were less familiar with programming, it was decided to migrate the software to Python.

4.4. Documentation and knowledge transfer

In this project that involved several generations of students taking over the work from the previous teams, avoidable delays and misunderstandings happened due to a lack of communication and formation of the new students that joined the project when the previous team left. To prevent this from happening again a good strategy for knowledge transfer is important. New students were recruited early in September 2021, giving ample time for them to understand the project and be integrated into the team before senior members departed in April 2022.

It is also essential to make a good effort to document all manipulations of the hardware, with detailed reports including photos. For the most critical operations and tests, composing step-by-step procedures and following them carefully has been found to be the best practice to have a proper record of these actions, and also to prove that all of them were executed correctly for the validation phase.

5. Conclusion

Phase D – Qualification and Production consisted of completing the manufacturing, assembly, integration, and environmental testing of the Artery in Microgravity experiment

cube. Many lessons were learned in this phase of the project which could provide valuable knowledge for students embarking on their own space-related educational activities. Special insight was provided on the implementation of design improvements to the AIM experiment cube, and the respective lessons that were learned throughout the design and AIT process.

Many of the challenges faced were related to qualifying a fluid-based experiment for a space mission. Careful selection of impermeable materials and sealing solutions for all interfaces has proven essential.

A good strategy of knowledge transfer between students' generations and across sub-teams is also key to avoiding unnecessary design iterations, for instance with electronics PCBs, saving precious time and cost.

In conclusion, the Artery in Microgravity project has been a unique and invaluable experience for all team members, with being involved in the dynamics of a real space project and having to meet all the typical requirements and reviews. All the students are eager to continue learning throughout the operations phase that will commence in mid-2022.

Acknowledgements

We would like to thank the sponsors of this project for their support: ESA Academy, Fondation ISAE-SUPAERO, Elastrat, Alvimedica and AIRBUS. Special thanks to Space Application Services, ISAE-SUPAERO and Politecnico di Torino.

References

- [1] O. Drayson, N. Bernardini, et al., *AIM (Artery In Microgravity): An ICE Cubes Mission by University Students*, 3rd SSEA, Leicester, United Kingdom, 2019
- [2] European Cooperation for Space Standardization, *Space project management*, p. 19, 2009
- [3] SurTec Website: <https://www.surtec.com/en/products-services/surtec-650/> , last visited: 21st March 2022.
- [4] Saint-Gobain Website: <https://www.processsystems.saint-gobain.com/products/tygon-s3-e-3603-food-beverage-dispensing-tubing> , last visited: 21st March 2022.