

Theory and Experimental Validation of Two Techniques for Compensating VT Nonlinearities

*Original*

Theory and Experimental Validation of Two Techniques for Compensating VT Nonlinearities / D'Avanzo, G.; Faifer, M.; Landi, C.; Laurano, C.; Letizia, P. S.; Luiso, M.; Ottoboni, R.; Toscani, S.. - In: IEEE TRANSACTIONS ON INSTRUMENTATION AND MEASUREMENT. - ISSN 0018-9456. - STAMPA. - 71:(2022), pp. 1-12.  
[10.1109/TIM.2022.3147883]

*Availability:*

This version is available at: 11583/2969091 since: 2022-07-05T10:05:26Z

*Publisher:*

Institute of Electrical and Electronics Engineers Inc.

*Published*

DOI:10.1109/TIM.2022.3147883

*Terms of use:*

This article is made available under terms and conditions as specified in the corresponding bibliographic description in the repository

*Publisher copyright*

(Article begins on next page)

# Theory and Experimental Validation of Two Techniques for Compensating VT Nonlinearities

Giovanni D'Avanzo<sup>1</sup>, Marco Faifer<sup>2</sup>, *Senior Member, IEEE*, Carmine Landi<sup>3</sup>, *Senior Member, IEEE*,  
Christian Laurano<sup>4</sup>, *Member, IEEE*, Palma Sara Letizia<sup>5</sup>, Mario Luiso<sup>6</sup>, *Member, IEEE*,  
Roberto Ottoboni<sup>7</sup>, *Fellow, IEEE*, and Sergio Toscani<sup>8</sup>, *Senior Member, IEEE*

**Abstract**—Inductive instrument transformers (ITs) are still the most used voltage and current sensors in power systems. Among the numerous applications that require their use, one of the most important is surely represented by harmonics measurement. In this case, the recent literature shows that, since they suffer from both a filtering behavior due to their dynamics and from nonlinear effects produced by their iron core, they can introduce errors up to some percent. This article wants to deeply investigate, in the very same experimental conditions, about the performance of two digital signal processing techniques, recently introduced for the improvement of harmonics measurements performed through ITs, namely, SINusoidal characterization for DIstortion COMPensation (SINDICOMP) and compensation of harmonic distortion through polynomial modeling in the frequency domain (PHD). These methods have been applied to two different voltage transformers, having different specifications, by using two measurement setups based on different architectures. The impact of the voltage generator employed during the identification on the achieved accuracy is theoretically and experimentally evaluated. Modified versions of SINDICOMP and PHD compensation, which are more robust against nonidealities of the measurement setup, are presented. The performances of the techniques are evaluated by adopting voltage waveforms similar to those that can be encountered during the normal operation in a real distribution grid.

**Index Terms**—Compensation, harmonic distortion (HD), harmonics, harmonics measurement, instrument transformer (IT), nonlinearity, power quality (PQ), power system measurements, voltage transformer (VT).

## I. INTRODUCTION

**I**N THE last decades, the penetration of power electronics-based devices in distribution systems has hugely increased. They include both loads but also generators, typically those

Manuscript received December 21, 2021; accepted January 16, 2022. Date of publication February 10, 2022; date of current version March 2, 2022. This work was supported by EMPIR programme co-financed by the Participating States and the European Union's Horizon 2020 Research and Innovation Programme under Grant 19NRM05 IT4PQ. The Associate Editor coordinating the review process was Yau Chung. (*Corresponding author: Mario Luiso.*)

Giovanni D'Avanzo is with Ricerca sul Sistema Energetico S.p.A., 20134 Milan, Italy, and also with the Dipartimento di Ingegneria, Università degli Studi della Campania "Luigi Vanvitelli," 81031 Aversa, Italy (e-mail: giovanni.davanzo@rse-web.it).

Marco Faifer, Christian Laurano, Roberto Ottoboni, and Sergio Toscani are with the Dipartimento di Elettronica, Informazione e Bioingegneria, Politecnico di Milano, 20133 Milan, Italy (e-mail: marco.faifer@polimi.it; christian.laurano@polimi.it; roberto.ottoboni@polimi.it; sergio.toscani@polimi.it).

Carmine Landi and Mario Luiso are with the Dipartimento di Ingegneria, Università degli Studi della Campania "Luigi Vanvitelli," 81031 Aversa, Italy (e-mail: carmine.landi@unicampania.it; mario.luiso@unicampania.it).

Palma Sara Letizia is with the Politecnico di Torino, 10129 Turin, Italy, and also with the Istituto Nazionale di Ricerca Metrologica, 10135 Turin, Italy (e-mail: p.letizia@inrim.it).

Digital Object Identifier 10.1109/TIM.2022.3147883

exploiting renewable sources. As a result, the availability of accurate harmonics measurements has become extremely important. In fact, they are the key quantities for power quality (PQ) and distortion-level assessment, disturbances source detection, and mitigation [1]–[5].

A typical measurement chain for PQ assessment makes use of proper voltage and current sensors as the input stage. In most cases, they are conventional or inductive instrument transformers (ITs) [6]–[8], whose primary side is subject to the current or voltage to be measured and scaled down at the secondary side (connected to a burden), ideally according to the turn ratio. Other kinds of transducers based on different operating principles are emerging; they have in common that their outputs are not asked to deliver a significant amount of power to the burden. In such a case, they are called low-power instrument transformers (LPITs) [6], [9] if they have an analog output or digital LPITs (DLPITs) if the output is digital [6], [9], [10].

Their performances in measuring harmonics strongly depend on the operating principle [11]. However, it is important to underline that, at the moment this article is written, there are no available international standards about how the performance of ITs has to be verified when they are employed for PQ measurements. A recently started research project, EMPIR 19NRM05 IT4PQ [12], has the aim of filling the gap in the knowledge about the behavior of ITs when measuring PQ phenomena, in order to support standardization committees (mainly International Electrotechnical Commission Technical Committee 38, IEC TC38 [13]) in the redaction of international standards on the topic.

As far as inductive voltage and current transformers (VTs and CTs), the recent scientific literature has shown that they suffer from both a filtering behavior, due to their dynamics [14], [15], and nonlinear effects, produced by the iron core [16]–[21]. As a result, neither the conventional calibration with a sinusoidal input nor the measurement of their frequency response is appropriate for their metrological characterization and the assessment of their contribution to measurements uncertainty when dealing with nonsinusoidal signals. On the contrary, the behavior of VTs and CTs in the presence of harmonics should be studied by applying distorted waveforms, resembling those typically found in power systems [22], [23]. Moreover, it was shown in [15]–[21] that both VTs and CTs can introduce errors up to some percent when they are used to measure harmonics without considering their complex behavior.

Considering the importance of harmonic measurements and the widespread diffusion of conventional ITs, several digital signal processing techniques aimed at mitigating their nonlinear behavior, thus improving their accuracy, have been proposed in the literature.

In particular, some of the authors recently proposed two simple yet effective methods: SINDICOMP [18] and the compensation of harmonic distortion (HD) through polynomial modeling in the frequency domain (PHD) [21]. Moreover, in [24], a preliminary comparison, only through numerical simulations, between the performance of these two techniques has been presented.

The main scope of this article is to highlight that, when the preliminary identification procedures required by these techniques are experimentally carried out in a laboratory environment, there are some nonidealities of the setup that, if not properly considered, could significantly reduce the achieved accuracy.

Therefore, the two techniques have been theoretically reformulated in order to model also these nonideal effects of the adopted setup, such as the presence of a direct current (DC) component (i.e., when the input voltage is obtained directly by an amplifier) and the undesired (but unavoidable) HD in the primary voltage.

The analyzed compensation techniques [18], [21] are applied to two commercial VTs, having different specifications. Moreover, two measurement setups with different architectures, one using a step-up transformer (SUT) and one using a medium-voltage (MV) amplifier (MVAMP), are used, highlighting their advantages and disadvantages.

This article is organized as follows. Section II gives a brief review of SINDICOMP and PHD compensation methods using a common mathematical formalism. Section III discusses the impact of the nonidealities of the used voltage generator on the performance of the techniques while proposing remedies. Section IV describes the architectures of the two different measurement setups used for the characterization of the commercial VTs. Section V gives a description about how the tests are performed and the used accuracy indexes to evaluate the performance of the techniques. Section VI deeply discusses the experimental results obtained with the two measurement setups. Finally, Section VII draws the conclusions.

## II. NONLINEARITY COMPENSATION TECHNIQUES

As stated in Section I, we have proposed two simple digital signal processing techniques, namely, SINDICOMP and PHD compensation, that enable significant accuracy improvements in harmonic measurements as far as a conventional VT is used as a transducer. In this section, these methods will be recalled using the same framework; it will also be stressed that some of the assumptions are shared by the two approaches.

A VT employed to measure harmonics in alternating current (AC) power systems can be considered as a nonlinear time-invariant system subject to a periodic multisine primary voltage  $v_1$  characterized by the fundamental frequency  $f_0$ , corresponding to the angular frequency  $\omega_0$ . Excluding chaotic phenomena (e.g., ferroresonance) while considering steady-state conditions, the secondary voltage  $v_2$  is a periodic multisine waveform characterized by the same period.

In this case, a frequency-domain Volterra (or polynomial) model [25]–[30] permits an accurate prediction of the  $m$ th-order secondary harmonic  $V_2(m)$  from the two-sided primary voltage spectrum, whose generic  $n$ th-order component is  $V_1(n)$  [17]. In terms of equations

$$V_2(m) = \sum_{i=1}^{\infty} V_2^i(m) = V_2^1(m) + V_2^{\text{NL}}(m) \quad (1)$$

where

$$\begin{aligned} V_2^1(m) &= H^1(m)V_1(m) \\ V_2^{\text{NL}}(m) &= \sum_{i=2}^{\infty} \sum_{n_1, \dots, n_i} H^i(n_1, \dots, n_i) \prod_{k=1}^i V_1(n_k) \\ \text{s.t. } n_1, \dots, n_i &\in \mathbb{Z}, \quad \sum_{k=1}^i n_k = m. \end{aligned} \quad (2)$$

When looking at (1), the secondary voltage harmonics results from infinite contributions  $V_2^i$ , each one produced by an  $i$ th degree homogeneous subsystem. The specific case  $i = 1$ , which has been put in evidence in (1) and (2), corresponds to the output of the underlying linear system whose frequency response is  $H^1$ ; the remaining contributions, considered by the term  $V_2^{\text{NL}}$ , are due to nonlinearity. In general, the  $i$ th degree contribution is a weighted sum of the products between all the possible sets of  $i$  components (with repetitions) in the two-sided spectrum of the primary voltage, whose sum of their harmonic orders  $\{n_k\}_{k \in \{1, \dots, i\}}$  is equal to  $m$ . The weights are given by  $H^i$ , which is the  $i$ th degree generalized frequency response function that determines the behavior of the corresponding subsystem.

It is worth reminding that the typical voltage waveforms in AC power systems have a peculiar (let us indicate it as quasi-sinusoidal) spectral content:  $v_1$  consists in the superposition of a strong fundamental at the rated frequency to harmonics having considerably smaller amplitudes (by more than an order of magnitude). Applying this consideration to the expression of  $V_2^{\text{NL}}$  reported in (2), the products between  $i \geq 2$  components, including at least a harmonic, have significantly smaller magnitudes with respect to those involving just the fundamental primary voltage or its complex conjugate image (thus,  $n_k \in \{1, -1\}$ ). Therefore, one may neglect the first kind of terms in the summation: it corresponds to consider the HD produced by the fundamental as the only nonlinear effect, thus assuming that there is no interaction (intermodulation) between different spectral components in the primary voltage. Scientific articles confirm that HD is the strongest nonlinear phenomenon jeopardizing the measurement of low-order, odd harmonics [17], [19], which are the most affected by nonlinearity. Introducing this simplification, after some passages, we obtain

$$V_2(m) \approx H^1(m)V_1(m) + \sum_{g=\max(0, 2-m)}^{\infty} H^i(m)|V_1(1)|^i e^{jm\varphi_1} \quad (3)$$

where  $\varphi_1 = \angle V_1(1)$  and  $i = 2g + m$  while the summation represents  $V_2^{\text{NL}}$ . It is worth noting that odd (even) harmonics are affected just by the contributions from odd (even) degree subsystems, namely, by odd (even) degree HD.

### A. SINDICOMP

The SINDICOMP technique [18] has been developed with ease of implementation as the primary target. Cataliotti *et al.* [18] reported a physically based explanation about how SINDICOMP can be applied to VTs. In this paragraph, the method will be revised in the framework of frequency-domain Volterra systems. When considering the fundamental component, nonlinear effects introduced by the VT are notably extremely small (albeit present) when compared to the accuracy class so that we can write

$$V_1(1) \approx K_C V_2(1) \quad (4)$$

where  $K_C$  is the complex ratio at the fundamental. Now, let us consider low-order harmonics; several works in the literature show that in this case, the performance bottleneck to the accuracy of VTs is represented by HD. Therefore, let us assume that for  $m \geq 2$ , the underlying linear system has flat magnitude response; using this hypothesis in (3) results in

$$V_2(m) \approx \frac{V_1(m)}{|K_C|} + V_2^{\text{sin}}(m)e^{jm\varphi_1}. \quad (5)$$

Reminding (3),  $V_2^{\text{sin}}$  is a function that only depends on the fundamental primary voltage magnitude, which can be directly reconstructed using (4). Thus, if  $V_2^{\text{sin}}$  were known, (5) can be easily inverted to obtain the primary harmonics from the secondary side.  $V_2^{\text{sin}}$  can be implemented as a lookup table, whose input is the fundamental magnitude. This lookup table can be built by feeding the VT with purely sinusoidal primary voltages having different amplitudes while measuring and storing the corresponding secondary voltage harmonics; for intermediate fundamental amplitude values,  $V_2^{\text{sin}}$  can be obtained through interpolation. A noticeable feature of SINDICOMP is that the preliminary identification procedure just requires applying sinusoidal waveforms.

### B. PHD Compensation

According to the peculiar spectral distribution of voltage waveforms in AC distribution grids, it is expected that (3) provides a good representation of the behavior of the VT. In this case, the nonlinear contribution  $V_2^{\text{NL}}$  to the secondary voltage just depends on  $V_1(1)$ . As stated in Section II-A, nonlinearity has a small impact on the fundamental term, and hence,  $V_1(1) \approx K^1 V_2(1)$ ; using it in (3), after some manipulations, it is possible to obtain an expression that enables obtaining the primary harmonics from the secondary spectrum

$$V_1(m) \approx K^1(m)V_2(m) + \sum_{g=\max(0,2-m)}^{\infty} K^i(m)|V_2(1)|^i e^{jm\varphi_2} \quad (6)$$

where  $\varphi_2 = \angle V_2(1)$ . Unfortunately, (6) cannot be used in practical applications since it is defined by an unlimited number of coefficients  $K^i(m)$ . The most natural solution is upper bounding to  $I$  the degree  $i$  of the homogeneous subsystems, as typically happens when Volterra-based systems are employed. In fact, a nonlinear model can be approximated with

a finite degree Volterra system for a given input range, just as a truncated Taylor expansion can approximate a continuous nonlinear function in the neighborhood of a point. In this case, (6) becomes

$$V_1(m) \approx K^1(m)V_2(m) + \sum_{g=\max(0,2-m)}^{\lfloor \frac{I-m}{2} \rfloor} K^i(m)|V_2(1)|^i e^{jm\varphi_2} \quad (7)$$

where  $\lfloor \cdot \rfloor$  denotes the floor function. For  $m$  greater than  $I$ , the reconstruction becomes linear: (7) is no longer able to compensate for the HD produced by the VT. Using vector notation, (7) can be written as

$$V_1(m) \approx \mathbf{W}^T(m)\mathbf{K}(m) \quad (8)$$

where

$$\mathbf{W}(m) = \begin{bmatrix} V_2(m) \\ \vdots \\ |V_2(1)|^{2\lfloor \frac{I-m}{2} \rfloor + m} e^{jm\varphi_2} \end{bmatrix} \quad \mathbf{K}(m) = \begin{bmatrix} K^1(m) \\ \vdots \\ K^{2\lfloor \frac{I-m}{2} \rfloor + m}(m) \end{bmatrix}. \quad (9)$$

Now, a method for estimating the coefficients  $K^i(m)$  must be selected. A possibility is feeding the VT with  $Q$  periodic multisine primary voltages (which is the set of identification waveforms) having fundamental frequency  $f_0$  and harmonic content similar to that found during typical operation while measuring the corresponding steady-state secondary spectra. For each waveform and harmonic order, an equation in the form (8) holds. Considering all the applied signals, a matrix relationship can be written

$$\mathbf{V}_{1,id}(m) = \mathbf{W}_{id}(m)\mathbf{K}(m). \quad (10)$$

Assuming that  $Q$  is greater than the maximum length of  $\mathbf{K}(m)$  and that the signals result in a full-column rank matrix  $\mathbf{W}_{id}(m)$ , estimating  $\mathbf{K}(m)$  is an overdetermined problem that can be solved in the least-squares (LS) sense. It is worth noting that the identification procedure does not require applying a specific set of signals, having assumed that they are representative of those found during typical working conditions.

### III. IMPACT OF THE VOLTAGE WAVEFORM GENERATOR

The practical implementation of the two techniques described in Section II needs a preliminary procedure aimed at identifying the coefficients of the compensation formulas. This requires a proper experimental setup capable of applying the set of training waveforms to the primary of the VT under test while observing its response. A power amplifier is generally used for the purpose; if its maximum output voltage capability is not enough to drive the VT under test, a boost transformer could be interposed. In general, this voltage generation system is not able to apply exactly the desired set identification waveforms. The impact of this nonideality on the performance achieved by the two methods will be analyzed in the following. During this section,



it is assumed that the primary and secondary spectra of the VT are exactly known. Anyway, in practical applications, their measurement uncertainties are typically negligible with respect to the accuracy of the voltage generator.

#### A. Impact on SINDICOMP

The training procedure of SINDICOMP first requires measuring  $K_C$  that is the complex ratio between the measured primary and secondary fundamental components in the VT under test. As in the usual calibration, the applied fundamental primary voltage should be reasonably close to its rated value and the primary harmonics must be low enough so that their effect on the fundamental secondary voltage is negligible. These conditions are easy to be fulfilled in calibration laboratories.

In order to build the lookup table that models  $V_2^{\text{sin}}$  at the different harmonics, the voltage generation system should be used to apply pure sinusoidal primary waveforms at different amplitudes. Unfortunately, spurious components modeled by the additive term  $\Delta V_1(m)$  are also injected because of the generator nonidealities. In turn, this produces a variation  $\Delta V_2(m)$  of the secondary harmonics with respect to purely sinusoidal conditions; a biased estimate  $\tilde{V}_2^{\text{sin}}$  of  $V_2^{\text{sin}}$  is thus obtained

$$\tilde{V}_2^{\text{sin}}(m) = V_2^{\text{sin}}(m) + \Delta V_2(m)e^{-jm\varphi_1}. \quad (11)$$

This produces a bias in the reconstructed primary harmonics  $\tilde{V}_1$ . Neglecting further error contributions due to interpolation between points of the lookup table, it leads to

$$\tilde{V}_1(m) = |K_C| \left[ V_2(m) - V_2^{\text{sin}}(m)e^{jm(\varphi_2 + \angle K_C)} - \Delta V_2(m) \right]. \quad (12)$$

For the moment, let us assume that no DC is applied to the primary of the VT, as it happens when the voltage amplifier is coupled by means of an SUT. In this case, the impact of  $\Delta V_1(m)$  can be heavily mitigated by assuming that it does not interfere with the fundamental and that the transformer ratio at the harmonics is the same as the fundamental (namely, the basic hypothesis of SINDICOMP). Therefore, it is possible to obtain an estimate of  $V_2^{\text{sin}}$  that is not biased by the unwanted components injected by the generator

$$\tilde{V}_2^{\text{sin}}(m) = \left[ V_2(m) - \frac{\Delta V_1(m)}{|K_C|} \right] e^{-jm\varphi_1} \approx V_2^{\text{sin}}(m). \quad (13)$$

If the voltage generation system does not employ a coupling transformer, DC may also be applied during identification, and thus,  $V_1(0) \neq 0$ . The previous technique cannot be used to remove the estimation error due to the DC. In fact, it is not directly reflected at the secondary side of the VT under test. On the contrary, even an extremely small DC term produces a DC magnetizing current (limited only by the DC resistance of the primary winding) that significantly affects core magnetization and, thus, the nonlinear behavior, especially at even-order harmonics. Some power amplifiers have a trim for controlling the DC offset, but it is often extremely difficult to make it low enough so that its impact is negligible. Furthermore, the DC output voltage may be affected by the generated waveform,

and it may be subject to significant drift after just few tens of seconds. A possible solution to this problem is modifying (5) so that it can consider the effect of the DC offset during identification. After proper identification, it would be possible to obtain the estimates of  $V_2(m)$  that are robust in the presence of generator output offset. In this respect, performance is as good as the underlying model is accurate in representing the impact of the DC component. For the sake of simplicity, let us suppose a linear dependence of the secondary harmonics with respect to the DC voltage. This is reasonable if we assume that the DC current is small with respect to the peak magnetizing current. Identification data can be obtained by repeating the measurement of each lookup table entry in the presence of  $R$  slightly different values  $V_1^{[r]}(0)$ ,  $r \in \{1, \dots, R\}$ , of the superimposed DC component (hopefully across zero), thus measuring  $\tilde{V}_2^{\text{sin}[r]}(m)$ . In turn,  $\tilde{V}_2^{\text{sin}}(m)$  is computed as the intercept of the LS fitting; the effect of the DC on the estimate is thus expected to be strongly mitigated.

#### B. Impact on PHD Compensation

As explained in the previous section, identifying the coefficients of the HD compensation formula (7) at the different harmonics requires feeding the VT with a proper set of periodic multisine identification waveforms and measuring the steady-state primary and secondary spectra. The estimates  $\tilde{\mathbf{K}}(m)$  of the corresponding vectors  $\mathbf{K}(m)$  are thus obtained as the LS solutions of (10). Now, let us suppose that the generation system is not able to inject exactly the set of the identification waveforms, but it introduces a no negligible deviation in the spectra. Let us assume for the moment that no primary DC component is applied and let us remember that we are neglecting measurement uncertainty. If the underlying model (7) of the identification problem (10) were exact, the variation of the identification waveforms due to the limited accuracy of the generator would not affect the estimates  $\tilde{\mathbf{K}}(m)$ . Actually, a small variation is expected since (7) is approximated, and thus, the identified coefficients are subject to definitional uncertainty. However, if a proper identification has been carried out, the impact of this effect is small with respect to the overall accuracy achieved by (7) in reconstructing primary harmonics.

Now, let us assume that the generation system applies also a DC term  $V_1(0)$  to the primary winding of the VT under test. If we use the identification technique as it is, the presence of the DC term (that typically changes over the different training signals) results in biased estimates of the coefficients. The reason is that, as mentioned in Section III-A, the DC interacts with the other primary components because of the nonlinearity of the iron core: this is not considered by the model that the HD compensation formula is based on.

In order to overcome this problem, the underlying polynomial model can be modified so that it becomes able to embed the interaction between DC and the fundamental primary voltage. Conversely, interactions between DC and the other primary components are neglected; this approximation is generally satisfactory due, once again, to the typical spectral content of voltage waveforms in AC power systems. Introducing  $B$  as the maximum power of  $V_1(0)$  included in the model,

TABLE I  
RATED CHARACTERISTICS OF THE ANALYZED VTs

	Rated primary voltage [kV]	Rated secondary voltage (V)	Rated burden [VA]	Accuracy class
VT <sub>A</sub>	3	100	25	0.5
VT <sub>B</sub>	20/√3	100/√3	30	0.5

a modified version of (7) is obtained

$$V_1(m) \approx K^1(m)V_2(m) + \sum_{b=0}^B [V_1(0)]^b \sum_{g=\max(0,2-m)}^{\lfloor \frac{L-h}{2} \rfloor} K^{i,b}(m) |V_2(1)|^i e^{jm\phi_2}. \quad (14)$$

It is worth highlighting that  $K^{i,0}$  in (14) corresponds to  $K^i$  in (7). Since (14) is linear in the parameters, the coefficients can be identified with the LS approach by following basically the same procedure described in Section II-B, thus obtaining the vectors  $\tilde{\mathbf{K}}_B(m)$ . In order to have an LS problem with full-column rank, a primary DC component that varies in the different identification signals must be present. Finally, the estimates of the parameters required by the compensation formula (7), namely of the elements of the vectors  $\mathbf{K}(m)$ , are just subsets of  $\tilde{\mathbf{K}}_B(m)$ . Since the impact of the DC is now properly modeled, these estimates shall be virtually unaffected by its presence.

#### IV. MEASUREMENT SETUP

The techniques introduced in Section II, together with the improvements presented in Section III, have been applied to enhance the harmonic measurement capability of two commercial VTs having 50 Hz rated frequencies (named VT<sub>A</sub> and VT<sub>B</sub> in the following) whose main features are listed in Table I.

Two measurement setups based on different architectures were used to implement the compensation methods and evaluate the achieved performance. The architecture of the first setup is widespread in many laboratories; it involves a low-voltage amplifier connected to an SUT to reach the required voltage levels; it has been employed, at Università degli Studi della Campania “Luigi Vanvitelli,” Aversa, Italy, to test VT<sub>A</sub>. The second one is less common, but it is that adopted by the Italian National Metrological Institute (INRIM), Turin, Italy; it employs an MVAMP having enough voltage output capability in order to directly drive the primary winding of the VT under test. This configuration has been employed to perform the tests on VT<sub>B</sub>. The detailed descriptions of the two measurement setups are provided in Sections IV-A and IV-B, respectively.

##### A. Setup With SUT

The generation and measurement setup based on the SUT is shown in Fig. 1. The reference voltage signal to be applied to the VT under test is provided by an arbitrary waveform generator (AWG) National Instrument (NI) PCI eXtension

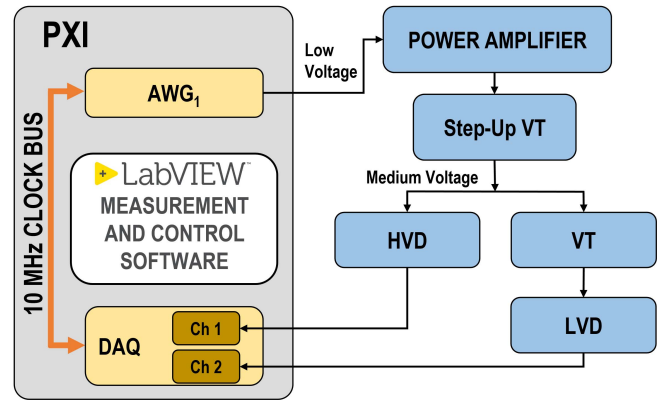

Fig. 1. Block diagram of the generation and measurement setup for the MV VT characterization with SUT.

for Instrumentation (PXI) 5422 (16 bit, variable output gain,  $\pm 12$  V output range, 200 MHz maximum sampling rate, and 256 MB of onboard memory). The AWG generates a 4 MHz clock that is used to derive the sampling clock; this allows obtaining coherent sampling, thus avoiding spectral leakage. Acquisition of the primary and secondary waveforms of the VT under test has been performed with a multifunction I/O module PXIe-6124 ( $\pm 10$  V, 16 bit, and maximum sampling rate 4 MHz). Waveforms have been sampled with a 10 kHz rate obtained through oversampling in order to reduce the impact of noise.

The output of the AWG is connected to an Arbitrary four-quadrant voltage and current amplifier Bolab ( $\pm 75$  V, 40 A, 1 kW, and 0 Hz–1 MHz) feeding the VT under test through a 100 V/24 kV SUT. Primary voltages are scaled with a commercial divider KV-10A [high-voltage divider (HVD)] having 1000:1 AC ratio and uncertainties on ratio and phase errors of, respectively, 130  $\mu\text{V}/\text{V}$  and 130  $\mu\text{rad}$  (level of confidence 95%) from DC up to 550 Hz. A low-voltage divider (LVD), having a ratio of about 18.5 V/V and uncertainties on ratio and phase errors of, respectively, 100  $\mu\text{V}/\text{V}$  and 110  $\mu\text{rad}$  (level of confidence 95%) from DC up to 550 Hz, has been designed and built for measuring the secondary voltage of the VT. Calibration of HVD and the LVD was performed at INRIM. The overall uncertainty (level of confidence 95%) of the measurement setup ranges up to 250  $\mu\text{V}/\text{V}$  and 250  $\mu\text{rad}$  for the measurement of the ratio error and the phase error, respectively, from DC up to 550 Hz.

##### B. Setup With MVAMP

The architecture of the experimental setup based on MVAMP is reported in Fig. 2. The voltage signal to be applied to the VT under test is generated by the AWG NI 5421 (16 bit, variable output gain,  $\pm 12$ -V output range, 100-MHz maximum sampling rate, and 256 MB of onboard memory). The AWG is installed in a PXI chassis, and the 10 MHz PXI clock is used as a reference clock for its phase-locked loop (PLL) circuitry. An additional NI PXI AWG generates a 12.8 MHz clock signal, which is provided to the acquisition system as time base clock: this ensures synchronized generation and acquisition of the signals. The acquisition system is composed of an NI compact data acquisition system (cDAQ) chassis

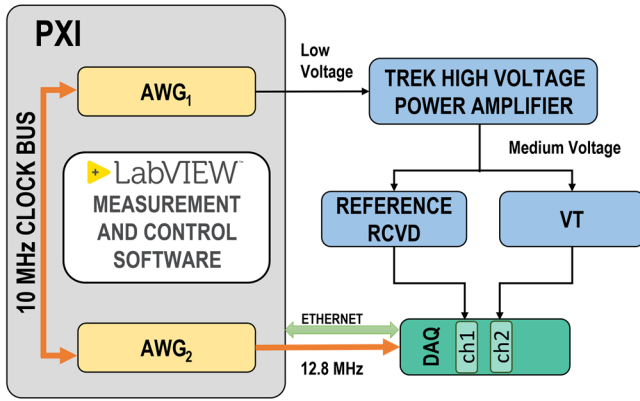

Fig. 2. Block diagram of the generation and measurement setup for the MV VT characterization with MVAMP.

with various input modules having a 24 bit resolution, 50 kHz maximum sampling rate, and input ranges from  $\pm 500$  mV to  $\pm 425$  V.

The signal generated by the AWG is applied to the primary winding of the VT under test by means of a Trek power amplifier (30 kV, 20 mA voltage and current output capability, and DC to 20 kHz bandwidth). The total HD of the generation systems is below 0.02% up to the 100th-order harmonic. The applied primary voltage waveforms are measured with a reference resistive capacitive voltage divider (RCVD) designed, built, and characterized at INRIM [31], [32]. It has a rated primary voltage equal to 30 kV and it is designed to have a flat frequency response from 0 Hz to 9 kHz. The overall uncertainty (level of confidence 95%) of the measurement setup ranges from  $70 \mu\text{V/V}$  and  $70 \mu\text{rad}$  at 50 Hz up to  $200 \mu\text{V/V}$  and  $350 \mu\text{rad}$  at 9 kHz for the measurement of the ratio error and the phase error, respectively.

## V. TEST DESCRIPTION

This section describes the tests and the indices used to analyze and compare the performance of SINDICOMP and PHD compensation techniques when applied to  $\text{VT}_A$  and  $\text{VT}_B$  (no burden connected to the secondary windings) due to the experimental setups described in Section IV. Three test types have been carried out: two of them are intended for the identification of the coefficients required by SINDICOMP and PHD compensation up to the 11th degree. The last one is the validation test: realistic voltage waveforms have been applied at the primary winding of the VT under test and the two techniques have been employed to reconstruct the harmonics from the secondary side spectrum. A detailed description of the tests is reported in the following.

### A. Identification of SINDICOMP

Estimating the coefficients required by SINDICOMP requires applying sinusoidal waveforms at the rated frequencies characterized by different amplitudes. In these tests, sine waves at about 80%, 100%, and 120% of the rated primary voltage of the VT under test have been applied. According to [8], they fully cover the measurement range for inductive VT. For each amplitude level, 1000 periods of the primary and secondary voltage waveforms have been acquired

and averaged in order to reduce the impact of noise. Due to coherent sampling, harmonics can be computed through the discrete Fourier transform (DFT) without being affected by aliasing artifacts.

### B. Identification of PHD Compensation

In order to identify the parameters of the HD compensation method, a class  $E_1$  of primary voltage multisines has been defined. They are characterized by a fundamental component at the rated frequency whose amplitude is a random variable having uniform probability density function (pdf) between 80% and 120% of the rated primary voltage of the VT under test. Harmonics up to the 25th order have been superimposed, and their amplitudes are uniformly distributed with a uniform distribution between 0.2% and 2% of the fundamental component. Phase angles are independent and uniformly distributed between  $-\pi$  and  $\pi$ . Identification data for PHD compensation are represented by  $Q = 100$  random waveforms extracted from this class. For each signal, 100 periods of the primary and secondary waveforms have been acquired; averages have been computed and harmonic components have been obtained through DFT. It is worth reminding that the first-degree PHD compensation is the best linear approximation (BLA) [28]–[30] of the VT for the class  $E_1$  of primary voltage waveforms.

### C. Validation Tests

The target is assessing the harmonic measurement performance that can be obtained, under realistic conditions, with SINDICOMP and PHD compensation. For this purpose, a new class  $E_2$  of primary voltage multisines (i.e., voltage waveforms containing all the harmonic components from the fundamental up to the 25th-order harmonic) have been defined, starting from the standard EN 50160 [33] that rules the voltage characteristics in public distribution grids. In particular, it reports the limits for the 10-min mean root-mean-square (rms) values of harmonic amplitudes (up to the 25th order) that should not be exceeded for more than 95% of the time over a one-week interval. These limits have been employed as 95th percentile values for harmonic amplitudes, assumed to be random variables. The fundamental component is supposed to be within 90% and 110% of its rated value for 95% of the time, and thus, they can be considered as 95th percentile bounds. However, the standard does not provide information about the probability distributions nor about phases. A Gaussian pdf with mean value equal to the rated voltage has been considered for the fundamental term. Relative harmonic amplitudes are supposed to follow Rayleigh distributions, while phases are considered as uniformly distributed between  $-\pi$  and  $\pi$ .  $S = 200$  primary voltage waveforms have been obtained by sampling the previously introduced pdfs and applied to the VTs under test. Also, in this case, 100 periods have been acquired and averaged for each validation waveform and spectra have been obtained by means of DFT.

### D. Accuracy Evaluation

The accuracy achieved by SINDICOMP and PHD compensation in reconstructing the primary voltage harmonics for the



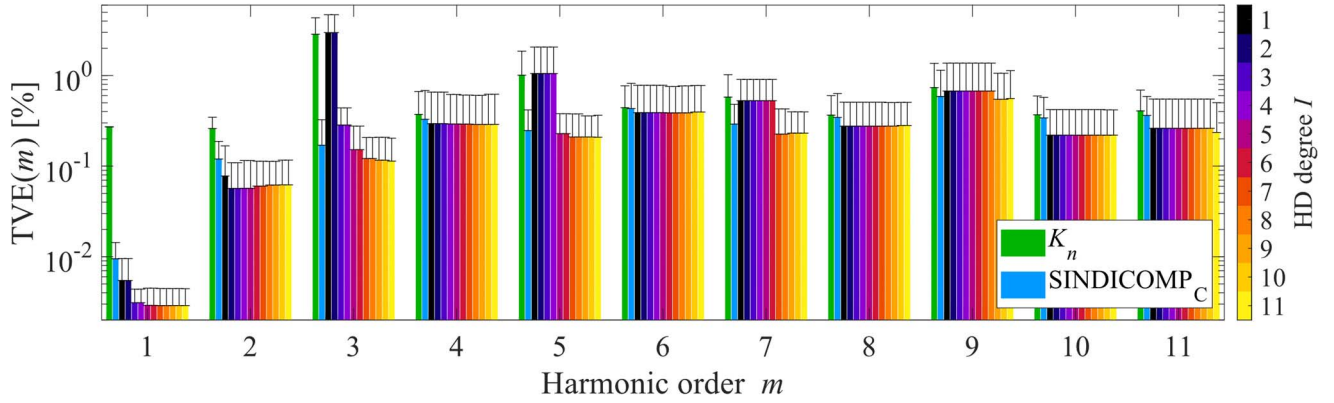

Fig. 3.  $VT_A$ : rms (bars) and 95th percentile values (error bars) of the TVEs obtained by reconstructing the primary voltage harmonics with nominal ratio using  $SINDICOMP_C$  and PHD compensation,  $I$  from 1 (BLA) to 11.

set of validation waveforms has been quantified in terms of total vector error (TVE). Considering the  $s$ th validation signal ( $s \in \{1, \dots, S\}$ ) and the  $m$ th-order harmonic, it is defined as

$$TVE^{[s]}(m) = \left| \frac{\tilde{V}_1^{[s]}(m) - V_1^{[s]}(m)}{V_1^{[s]}(m)} \right| \quad (15)$$

where  $V_1^{[s]}(m)$  is the  $m$ th-order harmonic phasor in the  $s$ th primary voltage waveform measured with the reference divider and  $\tilde{V}_1^{[s]}(m)$  is the corresponding reconstruction from the secondary side, obtained with one of the investigated methods. For each method and harmonic order, its rms and 95th percentile values over the  $S$  validation waveforms have been computed so that an overall accuracy index is obtained. Harmonic orders up to  $m = 11$  will be considered in the comparison. On the one hand, HD becomes very weak at higher harmonics. On the other hand, according to Section II-B, the considered PHD compensation having the highest (11th) degree cannot mitigate nonlinearity for  $m > 11$ .

Moreover, since according to [6] and [8], the metrological performance of a VT is provided in terms of ratio ( $\varepsilon$ ) and phase error ( $\Delta\varphi$ ), also, these quantities are evaluated for each signal and harmonic order. Their definitions, compliant with [8], are reported as follows:

$$\varepsilon^{[s]}(m) = \frac{|\tilde{V}_1^{[s]}(m)| - |V_1^{[s]}(m)|}{|V_1^{[s]}(m)|} \quad (16)$$

$$\Delta\varphi^{[s]}(m) = \angle\tilde{V}_1^{[s]}(m) - \angle V_1^{[s]}(m).$$

Finally, their average values and the 95th percentile bounds over the  $S$  validation waveforms have been computed for each harmonic order and reconstruction method.

## VI. EXPERIMENTAL RESULTS

This section compares the accuracies of voltage harmonic measurements achieved with the reconstruction techniques presented in Section II. In this respect, they have been applied to  $VT_A$  and  $VT_B$ , tested by using the experimental setup described in Sections IV-A (with SUT) and IV-B (with MVAMP), respectively. The effectiveness of the methods presented in Section III, which allows reducing the impact of the voltage generator nonidealities during identification, has also been investigated.

### A. Results With SUT

The coefficients required to apply  $SINDICOMP$  and PHD compensation (up to 11th degree) to  $VT_A$  have been identified using the experimental setup described in Section IV-A according to the procedures reported in Section V. The identification of  $SINDICOMP$ , which is highly sensitive to the spurious components introduced by the generation system, has been performed by adopting the compensation technique introduced in Section II; it will be indicated as  $SINDICOMP_C$ . The same setup has been employed to apply the validation waveforms belonging to class  $E_2$ ; harmonic voltages up to the 11th order have been reconstructed by using the aforementioned methods.

Achieved accuracy in terms of 95th percentile and rms value of the TVE is reported in Fig. 3; the results obtained with the nominal ratio  $K_n$  of the transformer have also been included in the comparison. As expected, using  $K_n$  at the fundamental results in a 95th percentile TVE (virtually identical to its rms value) of 0.27, which is fully compliant with the accuracy class of  $VT_A$ . This value can be significantly reduced using a properly calibrated complex-valued ratio, such as  $K_C$  for  $SINDICOMP$  or with the first-degree PHD compensation, which corresponds to the BLA. Higher order PHD compensation would enable even lower TVE values, but since they are already rather small, this reduction is not so meaningful from a practical point of view.

Adopting a linear model to reconstruct the components produces large errors, in particular at low-order odd harmonics, which are notably the most affected by nonlinearity and specifically by HD. For example, using  $K_n$ ,  $TVE^{95}$  reaches 4.4% and 1.9% at the third- and fifth-order harmonics, respectively. Values are slightly higher as long as the BLA is used, but this difference is not significant with respect to the statistical fluctuations due to the limited number of waveforms applied during the tests. The proposed compensation techniques provide a remarkable reduction at these harmonics. For example, when  $SINDICOMP_C$  is adopted, the 95th percentile TVE drops to 0.33% and 0.41% at the third- and fifth-order harmonics, respectively. PHD compensation provides a progressive error reduction as the degree  $I$  is increased: 0.20% and 0.35%  $TVE^{95}$  values are obtained at the third- and fifth-order harmonics, respectively.



It should be reminded that PHD compensation having a degree greater than  $m$  is necessary to compensate for nonlinearity at the  $m$ th-order harmonic, as clearly visible. Furthermore, it is possible to notice that passing from an odd degree PHD compensation to the next even, accuracy is virtually unchanged; including even degree terms in the model is not helpful to reduce the essentially odd degree HD produced by the VT.

The behavior observed at the seventh-order harmonic is similar to that observed at the third- and fifth-order harmonics, even if the error values and the accuracy improvement are less pronounced, because of the smallest impact of HD in this case.

The ninth-order harmonics is characterized by unusually high errors (if compared with typical VTs) as long as a linear reconstruction is adopted: TVE<sup>95</sup> is about 1.4% when using both  $K_n$  or the BLA. When adopting SINDICOMP<sub>C</sub> or PHD compensation, this value is reduced, but not dramatically (1.13%). This means that the ninth-order harmonic is affected by nonlinear effects, but not mainly by HD; intermodulation, which is not addressed by none of the proposed methods, is expected to play a major role in this case. Furthermore, when considering the class  $E_2$  of validation signals, it should be noticed that the ninth harmonic has the smallest expected amplitude with respect to all the other odd harmonics: this boosts the relative impact of nonlinearities. Similar considerations apply also to the 11th-order harmonic, but nonlinearity is weaker in this case.

TVE values at even-order harmonics are considerably smaller, but not negligible. It is worth reminding that considering the set of validation signals, even harmonics above the fourth have smaller expected amplitudes, and this increases the relative impact of nonlinearities. The proposed methods are not effective in improving measurement accuracy in this case; it is somewhat expected since they are barely affected by the mostly odd degree HD due to the transformer. Conversely, errors are mainly due to intermodulation, as happens for the higher order odd harmonics.

It should be noticed that at the 11th-order harmonic and for even harmonics above the fourth, the best linear reconstruction results in slightly lower errors with respect to that obtained with SINDICOMP<sub>C</sub>.

The measurement performance of VTs is usually quantified in terms of ratio and phase errors. In this respect, Figs. 4 and 5 show their average values and the 95th percentile bounds computed over the validation tests at the different harmonics. For better clarity, just the results obtained with  $K_n$ , with SINDICOMP<sub>C</sub>, and with the 11th-degree PHD compensation are shown. We can immediately notice that the amplitudes of the 95th percentile bands at the harmonics are strongly correlated with each other and with those of the TVE. Both SINDICOMP<sub>C</sub> and PHD compensation result in a dramatic reduction in the spread of the magnitude and phase error values, just as we observed in Fig. 3. From Fig. 4, we can notice that using the nominal ratio results in magnitude errors with positive bias; it becomes virtually negligible if SINDICOMP<sub>C</sub> or PHD compensation is employed.

Interesting considerations arise also from Fig. 5. When using  $K_n$  or SINDICOMP<sub>C</sub>, the phase error shows a bias

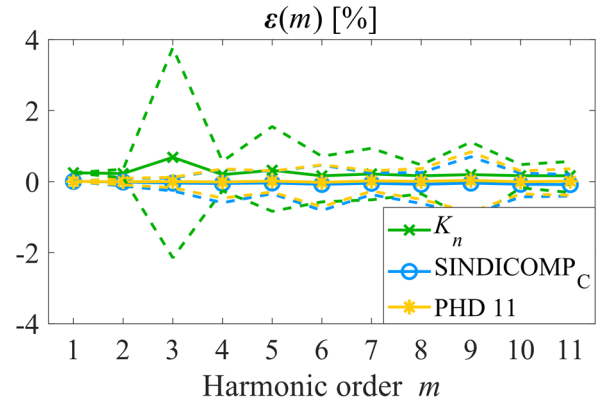

Fig. 4. VT<sub>A</sub>: average (solid lines with markers) and 95th percentile bounds (dashed lines) of the ratio error obtained with nominal ratio using SINDICOMP<sub>C</sub> and 11th-degree PHD compensation.

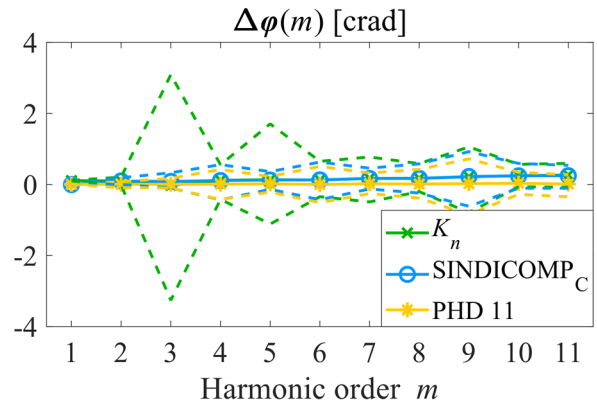

Fig. 5. VT<sub>A</sub>: average (solid lines with markers) and 95th percentile bounds (dashed lines) of the phase error obtained with nominal ratio using SINDICOMP<sub>C</sub> and 11th-degree PHD compensation.

that increases with frequency; conversely, the phase error obtained with PHD compensation is unbiased. The reason is the filtering behavior of the underlying linear system of the VT, which results in a frequency-dependent phase response. This is considered by the PHD compensation (the model includes the frequency response function of the linear subsystem) but not by SINDICOMP<sub>C</sub> since it assumes that the linear contribution to the secondary of the VT does not introduce a phase shift. This also explains why, at the 11th and even harmonics above the fourth, the BLA allows obtaining smaller TVE values with respect to SINDICOMP<sub>C</sub>; the filtering behavior has a higher impact than HD.

Finally, we want to stress the benefits of the compensation technique that enables a proper identification of SINDICOMP also when the generation system is not capable of applying sinewaves having negligible distortion with respect to the target accuracy. The architecture of the generation system based on the SUT represents a common and cost-effective solution; however, it may introduce significant spurious harmonic components produced by nonlinear effects. Reminding (12), when SINDICOMP is used, they cause biased reconstructions of the primary harmonics.

Considering the employed experimental setup based on the SUT, the amplitude of undesired odd-order harmonics may

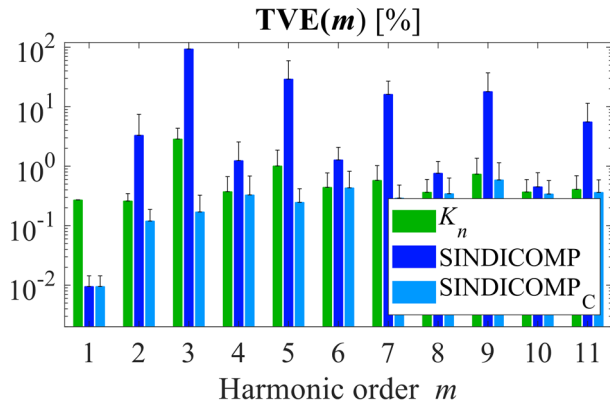

Fig. 6.  $VT_A$ : rms (bars) and 95th percentile values (error bars) of the TVE obtained with nominal ratio using SINDICOMP and SINDICOMP<sub>C</sub>.

exceed 1% of the fundamental one during the identification of SINDICOMP. Hence, from (12), the amplitude of the bias is expected to be comparable with the magnitude of the harmonics to be measured in typical voltage waveforms. Therefore, it is not surprising that using the conventional identification procedure for SINDICOMP leads to unacceptable results in this case, as shown in Fig. 6. The rms value of the TVE may be as high as 90% at the third-order harmonic, namely, the highest unwanted component that is injected during identification. Conversely, if the compensation technique for the distorted training waveforms is employed during identification (SINDICOMP<sub>C</sub>), we obtain an accurate reconstruction of the voltage harmonics. This method is extremely robust with respect to the characteristics of the employed generator; if a more accurate generation system is adopted, TVE values remain virtually unchanged.

### B. Results With MVAMP

After that, SINDICOMP and PHD compensation (up to the 11th degree) have been applied to transformer  $VT_B$  by using the experimental setup described in Section IV-B. In this case, the primary winding of  $VT_B$  is connected to an MVAMP, without a coupling transformer. Therefore, the output offset of the MVAMP is applied to the primary winding, and this may jeopardize the test results. For this reason, a closed-loop control of the output DC component has been implemented. The coefficients of PHD compensation and SINDICOMP have been estimated through the usual procedures; in the latter case, the compensation method for the spurious components injected by the generator has been adopted.

The same setup has been used to apply the set of validation waveforms; primary harmonics up to the 11th order have been reconstructed from the secondary side by using the considered techniques other than the nominal ratio  $K_n$ . Accuracy in terms of 95th percentile and rms TVE has been evaluated, and values are reported in Fig. 7; for the sake of brevity, only the results for odd degree PHD compensation are shown. Using  $K_n$  results in the largest errors, while reconstructing the harmonics with the BLA results in a dramatic improvement, except at the third-order one. Considering this component, most part of the error is due to nonlinearity; thus, it cannot be significantly mitigated with just a frequency response function. SINDICOMP<sub>C</sub>

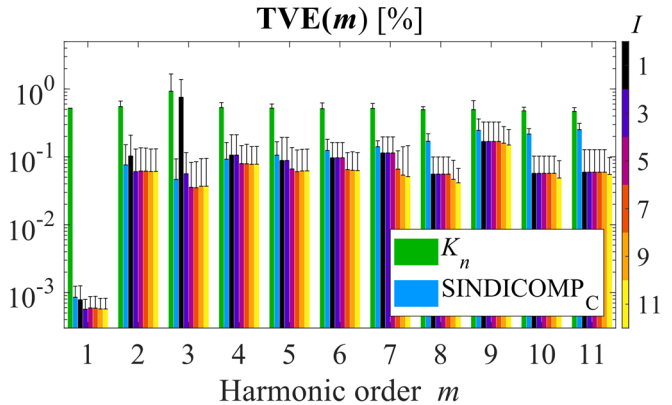

Fig. 7.  $VT_B$ : rms (bars) and 95th percentile values (error bars) of the TVE obtained with nominal ratio using SINDICOMP<sub>C</sub> and PHD compensation, odd  $I$  from 1 (BLA) to 11.

is extremely effective in reducing  $TVE^{95}$  at the third-order harmonic with respect to the best linear reconstruction: it drops from 1.4% to below 0.1%. On the contrary, the reduction is much less pronounced at the other harmonics. Moreover, above the eighth order, the BLA results in lower errors with respect to SINDICOMP<sub>C</sub>. As for  $VT_A$ , at these harmonics, the relative impact of HD is much less significant with respect to the phase error introduced by the filtering behavior of the VT under test. As expected, PHD compensation is particularly effective at low-order odd harmonics. At the third-order harmonic,  $TVE^{95}$  is below 0.09% for  $I \geq 3$ . When considering the fifth-order harmonic, the 95th percentile TVE is reduced from 0.6% (using  $K_n$ ) or 0.19% (with the BLA) to 0.12%; the reduction in terms of  $TVE^{rms}$  is even larger. The  $TVE^{95}$  value at the ninth-order harmonic is significant, but even using the PHD compensation, it remains the highest one among all the considered components. As explained in Section VI-A, it is the odd harmonic having the smallest expected amplitude according to the class  $E_2$  of excitation signals; this magnifies the impact of intermodulation, which is not considered by any of the proposed methods.

The voltage generation system based on the MVAMP is significantly more accurate than that including the SUT. In this respect, during the identification of SINDICOMP, unwanted harmonics are below 0.006% of the fundamental one. Although this value appears to be very small at a first sight, it still leads to a significant bias in the reconstructed harmonics. Fig. 8 compares the TVE values at the different harmonics when it is employed (SINDICOMP<sub>C</sub>) or not (SINDICOMP); it confirms that the compensation technique for the spurious components substantially lowers the performance requirements for the employed generator for effective implementation.

A problem to be faced when the power amplifier is directly connected to the transformer is that a DC component produced by offset may be applied to its primary winding. In the previous tests, output DC was set to be as small as possible before each waveform is applied (through an automatic closed-loop system) and checked during the test since it is subject to significant drifts just after tens of seconds. However, this

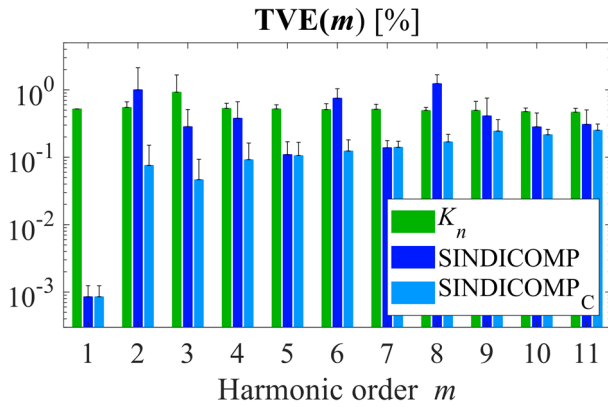

Fig. 8. VT<sub>B</sub>: rms (bars) and 95th percentile values (error bars) of the TVE obtained with nominal ratio using SINDICOMP and SINDICOMP<sub>C</sub>.

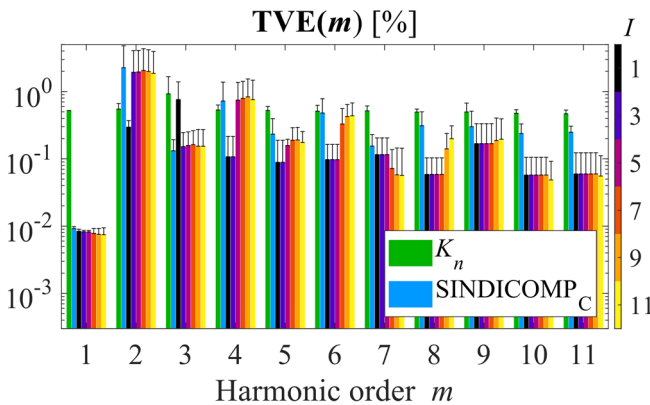

Fig. 9. VT<sub>B</sub>: rms (bars) and 95th percentile values (error bars) of the TVE obtained with nominal ratio using SINDICOMP<sub>C</sub> and PHD compensation, odd  $I$  from 1 (BLA) to 11; identification performed in the presence of DC.

increases the cost and complexity of the setup, other than the overall test duration. In order to investigate the impact of the offset and study possible remedies, the identification of SINDICOMP (with compensation of spurious harmonics) has been performed in the presence of a DC component whose magnitude is about 0.03% of the rated primary voltage. Conversely, the coefficients of PHD compensation have been estimated in the presence of a random DC component characterized by a uniform distribution between  $-0.01\%$  and  $0.06\%$  of the rated primary voltage of VT<sub>B</sub>. The obtained accuracy has been evaluated as usual and the results are reported in Fig. 9.

The superimposed DC components are rather small, and they could be representative of the typical output offsets of power amplifiers; nevertheless, they jeopardize the effectiveness of both the nonlinear reconstruction techniques, especially at low-order, even harmonics. The reason is that, during identification, significant contributions at even harmonics are generated because of the interaction between the fundamental and the DC offset. As a result, using SINDICOMP<sub>C</sub> or PHD compensation causes higher errors not only with respect to the BLA, but also using the nominal ratio provides better performance. In this respect, TVE<sup>95</sup> at the second- and fourth-

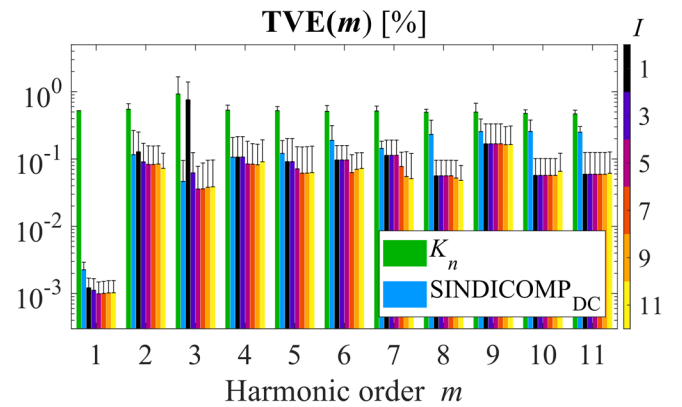

Fig. 10. VT<sub>B</sub>: rms (bars) and 95th percentile values (error bars) of the TVE obtained with nominal ratio using SINDICOMP<sub>DC</sub> and PHD<sub>DC</sub> compensation, odd  $I$  from 1 (BLA) to 11; identification performed in the presence of DC.

order harmonics exceeds 3.8% and 1.4%, respectively, with the nonlinear compensation techniques, while adopting  $K_n$ , the corresponding values are below 0.7%. In comparison, when identification was performed with negligible DC component, errors were lower than 0.15% using both SINDICOMP<sub>C</sub> and PHD compensation (Fig. 7). Accuracy at odd harmonics is less affected, but anyway, TVE values are significantly higher than those obtained when DC component was negligible during identification. For example, at the fifth-order harmonic, TVE<sup>95</sup> rises to 0.4% and 0.25% for SINDICOMP<sub>C</sub> and 11th-degree PHD compensation, respectively.

In order to increase the robustness of the estimated coefficients with respect to the presence of DC components during their identification, modified procedures have been proposed in Sections III-A and III-B; the basic idea is embedding in the model the effect of the DC. The enhanced identification procedure for SINDICOMP (denoted as SINDICOMP<sub>DC</sub>) requires that the lookup table is measured for different DC values; in this case, they are approximately  $-0.01\%$ ,  $0.03\%$ , and  $0.06\%$  of the rated primary voltage of VT<sub>B</sub>. Conversely, the same identification data with random DC component used to estimate the coefficients of PHD compensation have also been employed with the improved procedure, which will be called PHD<sub>DC</sub> compensation;  $B = 2$  has been adopted in this case and, thus, a second degree model in the DC component. The obtained results are reported in Fig. 10.

When comparing Figs. 10 with 9, the benefits allowed by the improved methods are evident. Accuracy now becomes very close to that obtained when DC was negligible during identification. As examples, TVE<sup>95</sup> at the second and third harmonics drops below 0.13% and 0.09% due to the enhanced PHD compensation, respectively; these values are very close with respect to those achieved with negligible DC offset during identification. It is worth highlighting that in this case, increasing the value of  $B$  above 2 is not beneficial, while it may increase the sensitivity to noise and uncertainty.

Similar considerations apply to SINDICOMP<sub>DC</sub>; in particular, the obtained performance justifies *ex post* the validity of having assumed a linear dependence between primary DC component and secondary harmonics during the identification.



In conclusion, these results prove the effectiveness of the improved identification methods, which are able to effectively cope with the possible presence of DC components; otherwise, the performance achieved by the considered reconstruction techniques would have been heavily affected.

## VII. CONCLUSION

This article has deeply analyzed the performance of two different digital signal processing techniques, namely, SINDICOMP and PHD compensation, used for the improvement of accuracy of VTs employed for harmonic measurements.

The main outcomes of this article can be briefly summarized as follows.

- 1) A new unified mathematical formulation for the two techniques has been introduced to directly compare them from a theoretical point of view.
- 2) The two techniques are tested in the very same experimental conditions, thus allowing for a straightforward comparison.
- 3) The accuracies reached by the techniques are verified by testing two commercial VTs with different specifications.
- 4) Two different measurement setups, one that uses an SUT and one that uses an MVAMP, are used for the characterization of commercial MV VTs and the advantages and disadvantages of their use are discussed from a theoretical and experimental point of view.
- 5) Modified identification procedures for SINDICOMP and PHD compensation, which are more robust against non-idealities of the generation system, are presented.
- 6) Results clearly highlight the benefits of the enhanced training procedures. SINDICOMP and PHD compensation properly operate even if a generator introducing significant HD or DC output offset is employed during identification.

It can be highlighted that both the techniques enable a strong improvement of the accuracy achieved by an inductive VT, especially at low-order odd harmonics; TVE reduces by at least 16 times at the third harmonic and up to a factor 5 at the fifth and seventh harmonics. When considering higher order components, using SINDICOMP results in larger errors with respect to PHD compensation since it does not model the filtering behavior of the VT; this is somehow balanced by the easier identification procedure. Finally, since both of the methods just require performing basic algebraic operations, their computational cost is low and this allows for easy implementation in new generation merging units and stand-alone merging units [34].

## REFERENCES

- [1] S. Elphick, V. Gosbell, V. Smith, S. Perera, P. Ciufu, and G. Drury, "Methods for harmonic analysis and reporting in future grid applications," *IEEE Trans. Power Del.*, vol. 32, no. 2, pp. 989–995, Apr. 2017.
- [2] X. Liang and C. Andalib-Bin-Karim, "Harmonics and mitigation techniques through advanced control in grid-connected renewable energy sources: A review," *IEEE Trans. Ind. Appl.*, vol. 54, no. 4, pp. 3100–3111, Jul. 2018.
- [3] M. Kaczmarek, "Inductive current transformer accuracy of transformation for the PQ measurements," *Electr. Power Syst. Res.*, vol. 150, pp. 169–176, Sep. 2017.
- [4] A. Kalair, N. Abas, A. R. Kalair, Z. Saleem, and N. Khan, "Review of harmonic analysis, modeling and mitigation techniques," *Renew. Sustain. Energy Rev.*, vol. 78, pp. 1152–1187, Oct. 2017.
- [5] D. Vieira, R. A. Shayani, and M. A. G. de Oliveira, "Reactive power billing under nonsinusoidal conditions for low-voltage systems," *IEEE Trans. Instrum. Meas.*, vol. 66, no. 8, pp. 2004–2011, Aug. 2017.
- [6] *Instrument Transformers—Part 1: General requirements*, document IEC 61869-1, 2007.
- [7] *Instrument Transformers—Part 2: Additional Requirements for Current Transformers*, document IEC 61869-2, 2012.
- [8] *Instrument Transformers—Part 3: Additional Requirements for Inductive Voltage Transformers*, document IEC 61869-3, 2011.
- [9] *Instrument Transformers—Part 6: Additional General Requirements for Low-Power Instrument Transformers*, document IEC 61869-6, 2016.
- [10] *Instrument Transformers—Part 9: Digital Interface for Instrument Transformers*, document IEC 61869-9, 2016.
- [11] *Instrument Transformers—The Use of Instrument Transformers for Power Quality Measurement*, document IEC TR 61869-103, 2012.
- [12] (Sep. 14, 2021). *EMPIR 19NRM05 IT4PQ Website*. [Online]. Available: [https://www.euramet.org/research-innovation/search-research-projects/details/project/measurement-methods-and-test-procedures-for-assessing-accuracy-of-instrument-transformers-for-power/?L=0&tx\\_eurametctp\\_project%5Baction%5D=show&tx\\_eurametctp\\_project%5Bcontroller%5D=Project&cHash=022ee6ab2e8ea8c12a7ed904625a1cc7](https://www.euramet.org/research-innovation/search-research-projects/details/project/measurement-methods-and-test-procedures-for-assessing-accuracy-of-instrument-transformers-for-power/?L=0&tx_eurametctp_project%5Baction%5D=show&tx_eurametctp_project%5Bcontroller%5D=Project&cHash=022ee6ab2e8ea8c12a7ed904625a1cc7)
- [13] (Sep. 14, 2021). *IEC TC 38 Website*. [Online]. Available: [https://www.iec.ch/dyn/www/f?p=103:7:0::FSP\\_ORG\\_ID,FSP\\_LANG\\_ID:1241,25](https://www.iec.ch/dyn/www/f?p=103:7:0::FSP_ORG_ID,FSP_LANG_ID:1241,25)
- [14] M. Kaczmarek and E. Stano, "Why should we test the wideband transformation accuracy of medium voltage inductive voltage transformers?" *Energies*, vol. 14, no. 15, p. 4432, Jul. 2021.
- [15] A. Cataliotti, D. D. Cara, A. E. Emanuel, and S. Nuccio, "A novel approach to current transformer characterization in the presence of harmonic distortion," *IEEE Trans. Instrum. Meas.*, vol. 58, no. 5, pp. 1446–1453, May 2009.
- [16] M. Kaczmarek and E. Stano, "Nonlinearity of magnetic core in evaluation of current and phase errors of transformation of higher harmonics of distorted current by inductive current transformers," *IEEE Access*, vol. 8, pp. 118885–118898, 2020.
- [17] M. Faifer *et al.*, "Overcoming frequency response measurements of voltage transformers: An approach based on quasi-sinusoidal Volterra models," *IEEE Trans. Instrum. Meas.*, vol. 68, no. 8, pp. 2800–2807, Aug. 2019.
- [18] A. Cataliotti *et al.*, "Compensation of nonlinearity of voltage and current instrument transformers," *IEEE Trans. Instrum. Meas.*, vol. 68, no. 5, pp. 1322–1332, May 2019.
- [19] S. Toscani, M. Faifer, A. Ferrero, C. Laurano, R. Ottoboni, and M. Zanoni, "Compensating nonlinearities in voltage transformers for enhanced harmonic measurements: The simplified Volterra approach," *IEEE Trans. Power Del.*, vol. 36, no. 1, pp. 362–370, Feb. 2021.
- [20] A. J. Collin, A. D. Femine, D. Gallo, R. Langella, and M. Luiso, "Compensation of current transformers' nonlinearities by tensor linearization," *IEEE Trans. Instrum. Meas.*, vol. 68, no. 10, pp. 3841–3849, Oct. 2019.
- [21] M. Faifer, C. Laurano, R. Ottoboni, S. Toscani, and M. Zanoni, "Harmonic distortion compensation in voltage transformers for improved power quality measurements," *IEEE Trans. Instrum. Meas.*, vol. 68, no. 10, pp. 3823–3830, Oct. 2019.
- [22] M. Kaczmarek and P. Kaczmarek, "Comparison of the wideband power sources used to supply step-up current transformers for generation of distorted currents," *Energies*, vol. 13, no. 7, p. 1849, Apr. 2020.
- [23] M. Kaczmarek and E. Stano, "Measuring system for testing the transformation accuracy of harmonics of distorted voltage by medium voltage instrument transformers," *Measurement*, vol. 181, Aug. 2021, Art. no. 109628.
- [24] G. D'Avanzo *et al.*, "Improving harmonic measurements with instrument transformers: A comparison among two techniques," in *Proc. IEEE Int. Instrum. Meas. Technol. Conf. (I2MTC)*, May 2021, pp. 1–6.
- [25] V. Mathews and G. Sicuranza, "Polynomial signal processing," in *Wiley Series in Telecommunications and Signal Processing*. Hoboken, NJ, USA: Wiley, 2000.
- [26] M. Schetzen, *The Volterra and Wiener Theories of Nonlinear Systems*. Hoboken, NJ, USA: Wiley, 2006.
- [27] W. J. Rugh, *Nonlinear System Theory—The Volterra/Wiener Approach*. London, U.K.: Johns Hopkins Press Ltd., 1981.
- [28] R. Pintelon and J. Schoukens, *System Identification. A Frequency Domain Approach*, 2nd ed. Boston, MA, USA, Wiley, 2012.
- [29] J. Schoukens, T. Dobrowiecki, and R. Pintelon, "Parametric and non-parametric identification of linear system in the presence of nonlinear distortion—A frequency domain approach," *IEEE Trans. Autom. Contr.*, vol. 43, no. 2, pp. 176–190, Feb. 1998.



- [30] M. Faifer, C. Laurano, R. Ottoboni, S. Toscani, and M. Zanoni, "Characterization of voltage instrument transformers under nonsinusoidal conditions based on the best linear approximation," *IEEE Trans. Instrum. Meas.*, vol. 67, no. 10, pp. 2392–2400, Oct. 2018.
- [31] G. Crotti *et al.*, "Frequency compliance of MV voltage sensors for smart grid application," *IEEE Sensors J.*, vol. 17, no. 23, pp. 7621–7629, Dec. 2017.
- [32] M. Zucca, M. Modarres, D. Giordano, and G. Crotti, "Accurate numerical modelling of MV and HV resistive dividers," *IEEE Trans. Power Del.*, vol. 32, no. 3, pp. 1645–1652, Jun. 2017.
- [33] *Voltage Characteristics of Electricity Supplied by Public Electricity Networks*, document EN 50160, 2010.
- [34] *Instrument Transformers—Part 13: Stand-Alone Merging Unit (SAMU)*, document IEC 61869-13, 2021.



**Giovanni D'Avanzo** was born in Naples, Italy, in 1991. He received the M.Sc. degree (*summa cum laude*) in electronic engineering from the University of Campania "Luigi Vanvitelli," Aversa, Italy, in 2019, where he is currently pursuing the Ph.D. degree in energy conversion.

He is currently with Ricerca sul Sistema Energetico S.p.A., Milan, Italy. He is working on various European metrology research projects. His research interests include the characterization of instrument transformers under power quality phenomena, the development of smart meters, and measurement systems for e-vehicles.



**Marco Faifer** (Senior Member, IEEE) was born in Bormio, Italy, in 1978. He received the Laurea degree in electronic engineering and the Ph.D. degree in electrical engineering from the Politecnico di Milano, Milan, Italy, in 2003 and 2009, respectively.

He is currently an Associate Professor with the Dipartimento di Elettronica, Informazione e Bioingegneria, Politecnico di Milano. His scientific activity is mainly concerned with DSP techniques and the development of industrial sensors and

devices for high-voltage measurements. Moreover, he develops measurement algorithms for the characterization of electrical components and materials. He also works in the field of diagnostics for electrical devices.



**Carmine Landi** (Senior Member, IEEE) was born in Salerno, Italy, in 1955. He received the Laurea degree in electrical engineering from the University of Naples, Naples, Italy, in 1981.

He was an Assistant Professor of Electrical Measurement with the University of Naples "Federico II," Naples, from 1982 to 1992. He was an Associate Professor of Electrical and Electronic Measurements with the University of L'Aquila, L'Aquila, Italy, from 1992 to 1999. He has been a Full Professor with the University of Campania "Luigi Vanvitelli"

(formerly Second University of Naples), Aversa, Italy, since 1999. He has authored almost 200 international articles in the field of real-time measurement apparatus, automated test equipment, high-precision power measurement, and power quality measurement. His main scientific interests are related to the setup of digital measurement instrumentation, the automatic testing of electrical machines such as asynchronous motors and power transformers, measurement techniques for the characterization of digital communication devices, and the use of digital signal processors for real-time measurements.

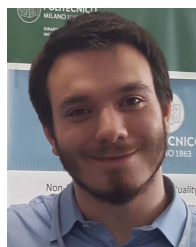

**Christian Laurano** (Member, IEEE) was born in Lodi, in 1990. He received the M.Sc. and Ph.D. degrees (*cum laude*) in electrical engineering from the Politecnico di Milano, Milan, Italy, in 2014 and 2018, respectively.

From 2018 to 2020, he was a Post-Doctoral Researcher with the Politecnico di Milano. From 2020 to 2021, he was with the Measurement and Diagnostic Group, Transmission and Distribution Technology Department, RSE SpA. He is currently an Assistant Professor with

the Dipartimento di Elettronica, Informazione e Bioingegneria, Politecnico di Milano. His main research interests include innovative methods to model and characterize electrical transducers, diagnostic techniques devoted to electrical grid components, and power quality monitoring.



**Palma Sara Letizia** was born in Caserta, Italy, in 1992. She received the M.Sc. degree (*summa cum laude*) in power electronic engineering from the University of Campania Luigi Vanvitelli, Aversa, Italy, in 2018. She is currently pursuing the Ph.D. degree in metrology with the Politecnico di Torino, Turin, Italy, and the Istituto Nazionale di Ricerca Metrologica (INRIM), Turin.

Her main scientific interest is metrology applied to power grids, in particular, the development of new procedures and reference sensors for power quality

and phasor measurement unit applications and the definition of traceable characterization methods for medium-voltage transducers under nonsinusoidal conditions.



**Mario Luiso** (Member, IEEE) was born in Naples, Italy, in 1981. He received the Laurea degree (*summa cum laude*) in electronic engineering and the Ph.D. degree in electrical energy conversion from the University of Campania "Luigi Vanvitelli," Aversa, Italy, in 2005 and 2007, respectively.

He is currently an Associate Professor with the Department Engineering, University of Campania "Luigi Vanvitelli." He has authored or coauthored more than 200 articles published in books, scientific journals, and conference proceedings. His main scientific interests are related to the development of innovative methods, sensors, and instrumentation for power system measurements, in particular power quality, calibration of instrument transformers, phasor measurement units, and smart meters.

Dr. Luiso is a member of the IEEE Instrumentation and Measurement Society.



**Roberto Ottoboni** (Fellow, IEEE) received the Laurea and Ph.D. degrees from the Politecnico di Milano, Milan, Italy, in 1987 and 1992, respectively.

From January 2009 to December 2012, he was the Chair of the Electrical Engineering Department, Politecnico di Milano. He is currently a Full Professor of Electrical and Electronic Measurements with the Dipartimento di Elettronica, Informazione e Bioingegneria, Politecnico di Milano. His research fields range from the study and analysis of digital signal processing techniques for measurement to the

study and implementation of sensors, transducers, and measurement systems for electrical quantities for industrial applications, with particular attention to innovative sensors for medium and high voltages and high currents.



**Sergio Toscani** (Senior Member, IEEE) received the M.Sc. and Ph.D. degrees (*cum laude*) in electrical engineering from the Politecnico di Milano, Milan, Italy, in 2007 and 2011, respectively.

From 2011 to 2020, he was an Assistant Professor of Electrical and Electronic Measurement with the Dipartimento di Elettronica, Informazione e Bioingegneria, Politecnico di Milano, where he currently serves as an Associate Professor. His research activity is mainly focused on the development and testing of current and voltage transducers, measurement techniques for power systems, electrical components, and systems diagnostics.

Dr. Toscani is a member of the IEEE Instrumentation and Measurement Society and the IEEE TC-39—Measurements in Power Systems.