

Low Latency Protocols Investigation for Event-Driven Wireless Body Area Networks

*Original*

Low Latency Protocols Investigation for Event-Driven Wireless Body Area Networks / Mongardi, Andrea; Rossi, Fabio; Pellegrino, Elia; Ros, Paolo Motto; Roch, Massimo Ruo; Martina, Maurizio. - ELETTRONICO. - (2021), pp. 01-06. (Intervento presentato al convegno 2021 IEEE Biomedical Circuits and Systems Conference (BioCAS) tenutosi a Berlin (Germany) nel 7-9 Ottobre 2021) [10.1109/BioCAS49922.2021.9644953].

*Availability:*

This version is available at: 11583/2947832 since: 2022-01-14T10:34:02Z

*Publisher:*

IEEE

*Published*

DOI:10.1109/BioCAS49922.2021.9644953

*Terms of use:*

openAccess

This article is made available under terms and conditions as specified in the corresponding bibliographic description in the repository

*Publisher copyright*

IEEE postprint/Author's Accepted Manuscript

©2021 IEEE. Personal use of this material is permitted. Permission from IEEE must be obtained for all other uses, in any current or future media, including reprinting/republishing this material for advertising or promotional purposes, creating new collecting works, for resale or lists, or reuse of any copyrighted component of this work in other works.

(Article begins on next page)

# Low Latency Protocols Investigation for Event-Driven Wireless Body Area Networks

Andrea Mongardi, Fabio Rossi, Elia Pellegrino, Paolo Motto Ros, Massimo Ruo Roch, Maurizio Martina  
Dipartimento di Elettronica e Telecomunicazioni, Politecnico di Torino, Torino, Italy, Email: maurizio.martina@polito.it

**Abstract**—Nowadays distributed electronic health and fitness monitoring are hot-topics in bio-engineering, however common solutions for Wireless Body Area Networks (WBANs) featuring high-density sampled data transmission still stumbles over the trade-off among data rate, application throughput, and latency. Therefore, the Bluetooth Low Energy (BLE) and the IEEE 802.15.4 protocols are here investigated, with the aim of developing an event-driven WBAN to support a threshold-crossing surface ElectroMyoGraphy (sEMG) acquisition approach. We then implemented a custom protocol to overcome their limitations and fulfil all the requirements, resulting in a transmission latency of  $0.856 \text{ ms} \pm 1 \mu\text{s}$  and enabling a functional operating time up to 110h.

**Index Terms**—wireless protocols, sEMG, Bluetooth Low Energy, IEEE 802.15.4, event-driven, low power

## I. INTRODUCTION

Advancements in wireless communication systems have a significant impact on human well-being: among the most promising wearable technologies, Wireless Body Area Networks (WBANs) confirmed their central role in monitoring human bio-signals [1], [2]. Generally, a WBAN consists of multiple sensors which first acquire and process physiological parameters and then exchange data with other nodes in the network, a central device or, eventually, with an actuator. More specifically, focusing on the transmission of muscular information carried by surface ElectroMyoGraphic (sEMG) signal, the WBAN is usually organized in a star topology [3], where each node senses sEMG and transmits it to a collector node for further processing. Some literature works [4]–[7] investigated the implementation of an efficient low-power WBAN for sEMG, showing pros and cons of commercial wireless protocols (e.g., Bluetooth Low Energy (BLE), Low Power Wi-Fi, IEEE 802.15.4) in terms of power consumption, payload, throughput and latency. Depending on the total number of sEMG channels, signal sampling (i.e., frequency and resolution) and device operating time [8], the strict dependency among payload, transmitter (TX) power and available throughput could represent a bottleneck for the spreading of this technology [9].

Aiming to resolve above issues, we proposed to extract the relevant information contained in the sEMG signal directly on sensor nodes, thus reducing data size and increasing application throughput, intended as the ratio between the time needed to send the informative content and the time needed for the transmission of the entire data packet. In [10], we have already demonstrated how to reduce the payload from 2 kB/s to 8 B/s (one channel information) by extracting Threshold Crossing

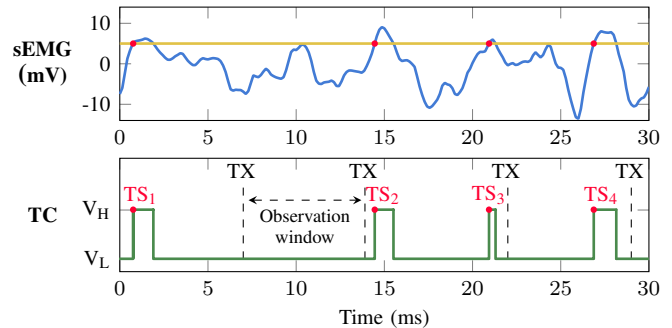

Fig. 1. Surface EMG is acquired, conditioned and amplified (above); then, a threshold is applied and only the TC events are considered for the transmission (below). Moving to fully event driven approach means to discard the notion of observation windows (ATC approach) and directly send, in real-time, the TC events, eventually tagged with a timestamp  $TS_x$  in case of a fixed periodic transmission.

(TC) events from amplified sEMG signal, and counting them over a time-window to obtain the Average Threshold Crossing (ATC) parameter. A conceptual example of the ATC approach, here with an observation window tied to a fixed transmission interval of 7.5 ms, is shown in Fig. 1, obtaining ATC values of 1, 0, 2, and 1, respectively. The key point in this approach is the event-driven nature of the data first acquired and then processed. Indeed, while in a biomedical application the benefits at the system-level have been clearly identified [11], [12], and the approach has been exploited both at the acquisition [13]–[16] and processing/actuation [17]–[19] stages, here the question is about which wireless communication solution would better fit into this kind of systems. While asynchronous event-driven wired protocols have been extensively investigated, both at the device (e.g., [20]) and at the system (e.g., [21]) level, the wireless domain has not received similar attention and, in particular, no attempt of leveraging standard, common wireless protocols or off-the-shelf components has been (yet) done. To the best of our knowledge, only full-custom wireless protocols, and corresponding ASIC implementations, have been so far investigated (showing promising results, e.g., [22], [23]). In this regard, even if the solution here proposed has been initially conceived for sEMG-related applications, the results are general enough to be extended to any event-driven WBAN (provided similar constraints and requirements).

In this paper, in order to promote a fully event-driven behavior of the WBAN, the sEMG signal acquisition will not consider anymore the windowing operation (resulting in

ATC values), rather it will directly send the TC events in real-time, as soon as they are detected. Indeed, the goal is to move towards a wireless bio-inspired communication as well, coherent with the implemented acquisition approach. The information content is encoded in the timings of the wireless transmission events, and therefore preserved all along the acquisition/transmission/processing stages [11], [12]. In this context, this means to investigate, and eventually develop, wireless protocols paying particular attention to the latency. Indeed, features like a fixed connection interval, or a subpar transmission latency accuracy, directly (negatively) affect the real-time performance of the system.

Here, considering the maximum theoretical TC bandwidth the same as sEMG (i.e., 500 Hz), and coding each TC event on a 1 B timestamp, our maximum theoretical application throughput will be equal to 500 B/s. However, although this has been one of the main constraints to identify the most suitable wireless protocols, it results overestimated w.r.t. real scenarios. Indeed, TC bandwidth hardly reaches 500 Hz since the combination of sEMG spectrum (major energy content in 50 Hz-150 Hz) and the threshold mechanism (acting as an activation offset) limits the frequency of TC events. Further, in case of no muscle activity, no TC events will be transmitted, fully exploiting an event-driven approach in this regard as well.

In a similar way we can estimate a first approximation of the maximum latency we can afford before needing to implement specific countermeasures on the receiving side, such as queuing/buffering packets or reordering events, which could impact on the overall performance of the system. Indeed, considering multiple transmitting devices, with the same clock/timebase but not synchronized among them (and assuming a negligible drift), a latency upper limit for directly processing the events as soon as they are received, could be the period of the equivalent minimum sampling frequency, in this case 1 ms (with an accuracy at least one order of magnitude below).

Considering this scenario, and following literature studies [4]–[10], this paper presents a feasibility study about the transmission of the TC signal, starting from commercial BLE, through low-level IEEE 802.15.4 protocol, and eventually implementing a custom version (built on top of a proprietary protocol of Nordic<sup>®</sup> Semiconductor), all on the same hardware platform, a Nordic<sup>®</sup> nRF52840 SoC, equipped with an ARM<sup>®</sup> Cortex<sup>™</sup>-M4 CPU and directly supporting multiple wireless protocols. Optimization in signal communication has been performed focusing on transmission latency and battery lifetime for a WBAN sensor node. A quantitative analysis [24], [25] concludes this work, taking into account TX current absorption, latency, throughput, transmission error and similarity of reconstructed TC signal.

## II. WIRELESS PROTOCOLS ANALYSIS AND DEVELOPMENT

The BLE protocol has been selected as starting point since it operates in the unlicensed 2.4 GHz Industrial Scientific and Medic (ISM) band, and its widespread use, joined with its low power performance, makes it a suitable choice for short-range WBAN communications. In Table I, data rate,

TABLE I  
PROTOCOLS OVERVIEW WITH THEORETICAL BEHAVIOR

	Data Rate	Physical TP <sup>1</sup>	Application TP <sup>1</sup>
BLE 4.2	1 Mbps	803.2 kbps	780.8 kbps
BLE 5.0	2 Mbps	1.434 Mbps	1.394 Mbps
IEEE 802.15.4	250 kbps	214.5 kbps	199.3 kbps
Custom LDR <sup>2</sup>	1 Mbps	n.a.	905.7 kbps
Custom HDR <sup>3</sup>	2 Mbps	n.a.	1.699 Mbps

<sup>1</sup>Throughput, <sup>2</sup>Low Data Rate, <sup>3</sup>High Data Rate

physical throughput, and application throughput are detailed, both for the 4.2 [26] and 5.0 [27] version, showing that in principle BLE could handle many more data than needed by the application (i.e., the available payload is 244 B, in a 265 B physical packet). However, it allows two peers to exchange information only in fixed amounts of time [28, Chapter 2], called connection intervals, which can be set between 7.5 ms and 4 s. This value has the most relevant impact on latency: indeed, the physical time needed to encode, send and decode the packet is almost negligible concerning the connection interval set.

The IEEE 802.15.4 standard protocol [29] could solve the latency issue, not being based on connection intervals, but allowing a continuous data streaming. Besides that, the lower data rate of 250 kbps slightly increases the transmission latency, and the reduced physical packet dimension (the physical payload is at most 128 B) makes this protocol a borderline solution for a multi-board scenario. Keeping in mind these considerations, it will be analyzed focusing on its low-level implementation, to verify if its reduced performance could still handle the needed amount of data.

Having some difficulties to find a suitable commercial protocol for the TC events transmission, a custom version of the BLE stack has been developed as well. This custom protocol aims to maintain the BLE structure at the application level in order to let user interfaces still correctly understand received data without any further change in the firmware, while totally shaking up the physical behavior to reduce the latency as much as possible. In particular, latency has been minimized by these improvements:

- The connection interval has been removed, allowing two consecutive connection events to be distanced by only an Inter-Frame Spacing (IFS) of 150  $\mu$ s, without waiting for 7.5 ms or more.
- The packet overhead has been reduced, avoiding unnecessary bytes of header and footer, and skipping a few layers of encapsulation (i.e., moving from application layer directly to physical layer), thus going from the 21 B of BLE to only 9 B of non-informative data.
- The acknowledgment packet has been removed from the protocol, saving 80  $\mu$ s or 40  $\mu$ s (depending on the data rate), and making a second IFS superfluous.
- The re-transmission mechanism of BLE has been inhibited, also because of the lack of acknowledgment, thus avoiding making subsequent packets wait in the link

layer. The potential on-air packet loss would not significantly affect application behavior, as already demonstrated in [30].

Aiming to check power performance, the physical data rate has been left configurable for this custom protocol too, thus making possible to distinguish between two different versions of it: one at Low Data Rate (LDR) and the other at High Data Rate (HDR).

### III. NETWORK DEVICES DESIGN AND DEVELOPMENT

Our WBAN architecture has been simplified to a peer-to-peer communication in order to completely analyze data transmission between TX and receiver (RX) nodes (both implemented on nRF52840 development kits) in an easily supervised scenario. Data at TX unit have been organized as follows: considering the distance among TX transmissions (often known as connection interval, fixed at connection setup time in multiple standard protocols), we defined an events capture period with a width equal to the minimum BLE connection interval (i.e., 7.5 ms), within which a relative (to the beginning of the capture) 8 bit timestamp has been associated to each TC event (see Fig. 1). The resulting packet consists of a progressive number to identify the observation, a channel ID (for future development), an events count, which can be used as reliability indicator, and the TC timestamps. In this way, the receiver board could recover the original timings of the acquired signal with a good accuracy (and therefore its information content, in a fully event-driven perspective), depending only on the timer resolution and accuracy.

The events capture window has been adopted for all the implemented protocols, in order both to keep the transmission timings stable, thus easing the final comparison, and to limit the transmission activity itself, reducing power consumption.

Furthermore, to avoid external factors that could misrepresent the results of the study, some precautions have been taken:

- The TX and RX hardware were the same ones, thus the power consumption is strictly dependent only on the firmware implemented;
- The TC signal was not acquired in real-time but it has been digitized onto the internal memory of the TX board, and it was always the same across the different trials: in this way acquisition artifacts were avoided;
- The implementation of each wireless protocol has been developed following the same Finite State Machine (FSM) configuration and maintaining the same communication paradigm.

The only configurable differences between the protocols remain the payload size and the data rate. The latter has been tested in both available configurations (i.e., 1 Mbps or 2 Mbps), causing an experimental comparison based on five different protocol versions (i.e., BLE 4.2, BLE 5.0, IEEE 802.15.4, custom LDR, and custom HDR). On the other hand, payload size has been increased to take into account future implementations with more acquisition devices relying on the

same wireless connection. For the sake of simplicity, without loss of generality, the payload for both the BLE and the custom protocol has been set to 200 B, and the IEEE 802.15.4 has been configured to carry an actual content of 100 B.

### IV. EXPERIMENTAL SETUP

The experimental setup is shown in Fig. 2. TX and RX boards have been placed 1.5 m apart, considering the average distance between typical WBAN nodes. An additional board, acting as an unbiased time recorder, has been connected to both TX and RX to capture the exact moment of the transmission and reception of packets. The three boards were connected to a personal computer, where important data were saved using a Python™ serial interface and post-processed with MATLAB®, in order to compute:

- Throughput, computed as the number of information bits transmitted each second;
- Transmission error, computed as the ratio between the number of lost packets and transmitted ones;
- Latency, which represents the time needed to encode, send and decode the entire packet;
- TC similarity, computed between the transmitted TC signal and the reconstructed one.

Furthermore, to evaluate the instantaneous current consumption of the boards, an external shunt resistor was placed in series to the battery voltage source. The resulting voltage drop was amplified of a factor of 5 by a Texas Instrument INA126P instrumentation amplifier and measured by means of a Rigol MSO5104 oscilloscope.

The Radio Frequency (RF) output power, highly correlated with the Effective Radiated Power (ERP), was set between -20 dBm and 8 dBm in order to study its impact on the parameters explained above.

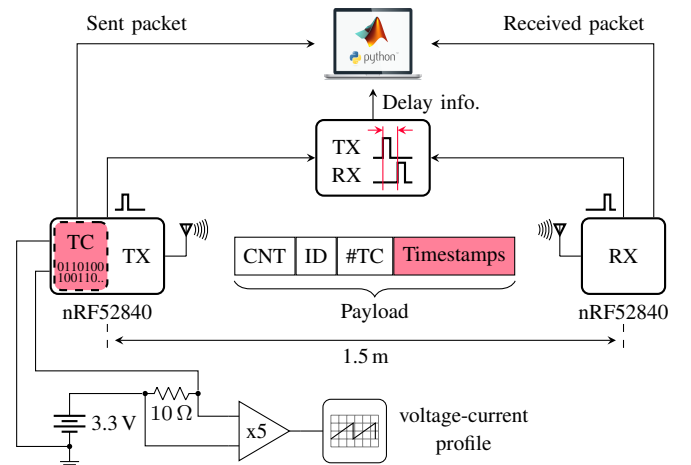

Fig. 2. Experimental setup: the two communicating boards are wired to a support device which acquires timing information. The acquired data are then sent to a computer which post-processes the information and evaluate multiple parameters. To also measure power consumption, a shunt resistor is placed in series with power supply.

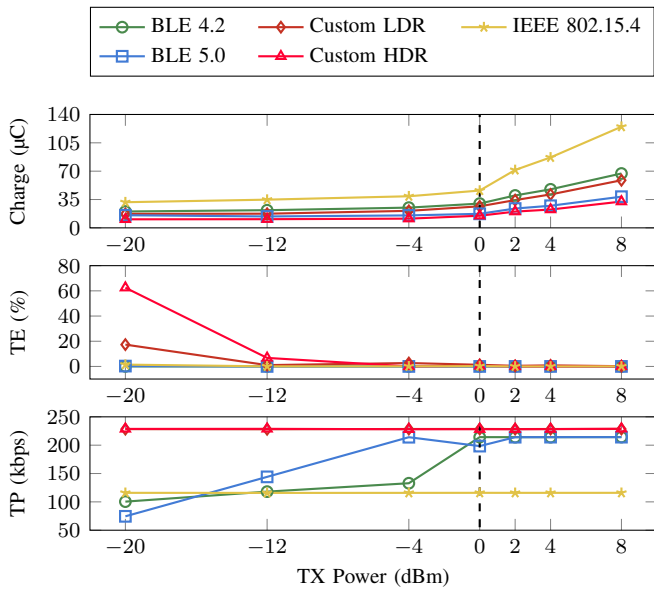

Fig. 3. Charge consumption, transmission error (TE) and throughput (TP) assessment, on varying the RF output power. The best trade-off can be identified at 0dBm.

## V. RESULTS AND DISCUSSION

Experimental results comparison, among the five identified protocol versions, has been performed in two distinct phases: first of all, energy consumption, transmission error, and throughput have been measured and analyzed together (see Fig. 3), on varying the RF output power, in order to identify the ERP value which could represent the best trade-off for our simplified WBAN application; then, with fixed TX power, a second analysis on latency and TC similarity (summarized in Table II) has been carried out to find the most suitable protocol for our event-driven transmission. Indeed, the selected wireless protocol should ensure a good throughput to allow a high exchange of data, should maintain low latency to fit real-time applications, and should keep a stable transmission over time to not distort the transmitted TC signal.

### A. Preliminary assessment of transmission power

The charge consumption (i.e., the quantity of electrical charge required to perform a certain task) is both dependent on the finite amount of time needed to transmit an entire packet, and on the RF output power set (higher values allow the device to transmit at longer distances but also increasing related energy consumption). In particular, regarding the transmission time, energy consumption is strictly dependent on the configured data rate (considering our constant packet size configuration): indeed, since the maximum instantaneous current absorption reached similar values for all the tested protocols (i.e., the power requested by the antenna during transmission), lower data rates require an higher amount of time to send a packet w.r.t. higher data rates, thus increasing the total charge consumption for a single transmission event, and vice versa.

According to experimental measures, the protocols power consumption matches the theoretical behavior, having obtained three distinct profiles on varying the RF power (as reported in the top chart of Fig. 3). In fact, as expected, BLE 5.0 and custom HDR are the less power hungry protocols (i.e., they consume about  $35 \mu\text{C}$  at 8 dBm), being the fastest among the five we considered. The little offset among them, slightly advantaging the custom HDR protocol, has to be attributed to the bigger overhead of the BLE, which makes its transmission last little longer. The charge consumptions of BLE 4.2 and custom LDR have a similar trend, resulting in bigger values (i.e., about  $60 \mu\text{C}$  at 8 dBm) due to their slower physical data rates, but maintaining the relative relation between the two. Last and most consuming, the IEEE 802.15.4, with its data rate of only 250 kbps, requires up to  $125 \mu\text{C}$  to transmit a packet, even considering the reduced payload.

Regarding transmission errors, as reported in the middle chart of Fig. 3, both IEEE 802.15.4 and BLE lose very few packets, due to spread spectrum techniques and re-transmission mechanism, respectively. Custom protocols, instead, struggle to make packets correctly arrive to the receiver, especially with a RF power set under  $-4$  dBm. In fact, the design choice to neglect BLE re-transmission mechanism, as described in Section II, makes our protocol not concerned about losing packets, but going forward with newest ones, to avoid a transmission bottleneck.

The throughput analysis (bottom chart of Fig. 3) concludes this preliminary assessment. IEEE 802.15.4 and custom protocols maintain a stable transmission rate over all the tested RF output power levels, corresponding to 115 kbps and 228 kbps, respectively. However, the re-transmission mechanism implemented by the BLE stack, which guarantees the proper reception of each transmitted TX packet at RX node, could cause the discard of some not transmitted packets because of the delayed reception of the acknowledge from previous messages. This data loss is similar to the transmission error related to the custom protocol, but happens in terms of throughput, when the information is still at TX node.

Considering these three parameters together, it is easy to find a good trade-off in terms of transmission power at the 0 dBm RF level. In fact, all the charge profiles have a significantly steeper trend beyond this value, and the transmission error and throughput issues both are progressively well stable before reaching it (i.e., beyond 0 dBm there seems to be a kind of law of diminishing returns). Furthermore, the low data rate versions of BLE and custom protocols have been discarded, not having a single advantage w.r.t. their high data rate siblings.

### B. Accurate real-time TC reconstruction

Having identified the 0 dBm RF output power as the good trade-off for our small WBAN, we could finally focus on latency. From experimental measures, we could observe how the stack used in the development of BLE did not ensure a good synchronization between transmitter and receiver, bringing some packets to be sent up to several connection

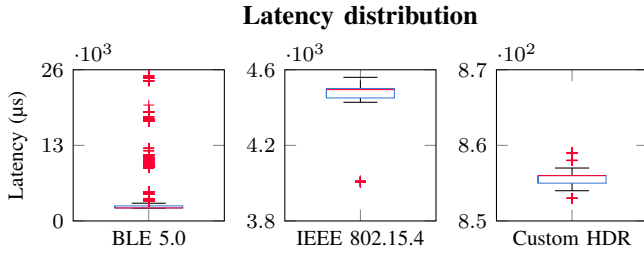

Fig. 4. Distribution of latency over different trials. Note that each chart has its own y scale, but same measurement unit (i.e.,  $\mu\text{s}$ ). The BLE latency is regularly determined by the connection interval, thus resulting in few condensed spots every 7.5 ms (the graphical representation is focused on the behavior around median latency and it has therefore been limited to 26 ms, even if the maximum value reached is 240.8 ms).

intervals later. Indeed, while for IEEE 802.15.4 and custom protocol data distribution is pretty narrow, with few outliers and the majority of acquired values grouped around the relative median (i.e., 4.495 ms and 0.856 ms, respectively), for BLE the statistical distribution shows many clusters of outliers centered at values multiple of the connection interval (with a maximum at 240.8 ms), far away from the median value (i.e., 2.236 ms). As depicted in Fig. 4, in all cases, the median latency would be suitable for real-time transmission, but the poor statistical distribution of the BLE protocol makes it lack reliability.

As last performance indicator, TC similarity is used to compare the acquired TC signal with respect to the reconstructed signal at RX side. In particular, the similarity has been evaluated on events distribution, calculating two features, over equal length moving time-windows (without overlap):

- $f_1$ : distance (in time) between consequent events;
- $f_2$ : number of events in correspondent time-windows.

Two different evaluators have been selected: the cosine similarity and the Jaccard index [31], [32], whose mathematical formulation has been reported in (1) and (2), where the  $A$  and  $B$  arrays are the transmitted and received TC features:

$$\cos(A, B) = \frac{\sum_{i=1}^n a_i \cdot b_i}{\sqrt{\sum_{i=1}^n a_i^2} \cdot \sqrt{\sum_{i=1}^n b_i^2}}, \quad (1)$$

$$jac(A, B) = \frac{\sum_{i=1}^n \min(a_i, b_i)}{\sum_{i=1}^n \max(a_i, b_i)}. \quad (2)$$

An error has then been estimated computing the number of time each evaluator went beyond 95%. The overall TC similarity has been calculated as reported in (3), simply

averaging together the two evaluators and their relative errors for both features:

$$TC_{sim} = \frac{\cos_{f_1} + \cos_{f_2} + jac_{f_1} + jac_{f_2}}{4} + \frac{err_{\cos_{f_1}} + err_{\cos_{f_2}} + err_{jac_{f_1}} + err_{jac_{f_2}}}{4}. \quad (3)$$

As reported in Table II, both IEEE 802.15.4 and custom protocol show a reliable transmission, with almost zero distortion, obtaining a score over 99%. However, BLE struggles to correctly reconstruct the 70% of the signal, due to the unstable latency also at the 0 dBm power level, which should theoretically be sufficient to cover the distance between transmitter and receiver. Indeed, the high variance of the latency could both bring to a packet loss at stack level and make received events to fall out of their original observation window, resulting in misinterpretation of the received data.

## VI. CONCLUSION AND FUTURE PERSPECTIVES

In this work, five different wireless protocols configurations (i.e., BLE 4.2, BLE 5.0, IEEE 802.15.4, custom LDR, and custom HDR) have been studied and tested to find the best one for an event-driven sEMG acquisition system, in terms of energy consumption, transmission error, throughput, latency, and reliability.

The observed experimental behavior perfectly matched the theoretical analysis performed at the beginning of this study, as summarized in Table II. In particular, BLE showed good performance in terms of power consumption and error rate, but performed poorly regarding latency: some packets could be randomly sent few connection intervals later, bringing to a distortion of transmitted TC signal. IEEE 802.15.4 performed poorly in terms of energy consumption due to its low bit rate, which increases the time the antenna has to stay active, but maintained low latency and transmission error, thanks to the spread spectrum technique used in physical layer.

A custom protocol has been then implemented on the same hardware platform. Once properly tuned, it overcame the main issues we had with commercial protocols: the latency, which shows a normal distribution over different trials, is always less than 1 ms with a standard deviation under  $1 \mu\text{s}$ , and the maximum estimated charge consumed for a single transmission of a 200 B payload is equal to  $14.98 \mu\text{C}$ . Considering a small 220 mAh battery and a connection interval of 7.5 ms, the lifetime of our TX device is thus estimated to be around 110 h. If needed, it could be further improved by optimizing the connection interval, either to reduce power consumption or to decrease latency, according to the requirements of each application.

Future networks implementations could include more wireless nodes, thus verifying the effectiveness of the protocol in a more complex scenario.

## REFERENCES

- [1] D. D. Olatinwo, A. Abu-Mahfouz, and G. Hancke, "A survey on LPWAN technologies in wban for remote health-care monitoring," *Sensors*, vol. 19, no. 23, 2019. [Online]. Available: <https://www.mdpi.com/1424-8220/19/23/5268>

TABLE II  
PROTOCOLS WITH PARAMETER EVALUATION AT 0 dBm

Protocols	TP (kbps)	Latency (ms)			TC <sub>sim</sub> (%)	Charge ( $\mu\text{C}$ )
		min	median	max		
BLE 5.0	214.19	2.167	2.236	240.8	67.41	17.34
IEEE 802.15.4	115.95	4.005	4.495	4.560	99.54	46.06
Custom HDR	228.60	0.853	0.856	0.859	99.91	14.98

- [2] R. Li, D. T. H. Lai, and W. Lee, "A survey on biofeedback and actuation in Wireless Body Area Networks (WBANs)," *IEEE Reviews in Biomedical Engineering*, vol. 10, pp. 162–173, 2017.
- [3] K. Hasan, K. Biswas, K. Ahmed, N. S. Nafi, and M. S. Islam, "A comprehensive review of wireless body area network," *Journal of Network and Computer Applications*, vol. 143, pp. 178–198, 2019. [Online]. Available: <https://www.sciencedirect.com/science/article/pii/S1084804519302218>
- [4] D. Brunelli, E. Farella, D. Giovanelli, B. Milosevic, and I. Minakov, "Design considerations for wireless acquisition of multichannel sEMG signals in prosthetic hand control," *IEEE Sensors Journal*, vol. 16, no. 23, pp. 8338–8347, 2016.
- [5] G. Biagetti, P. Crippa, L. Falaschetti, and C. Turchetti, "A multi-channel electromyography, electrocardiography and inertial wireless sensor module using bluetooth low-energy," *Electronics*, vol. 9, no. 6, 2020. [Online]. Available: <https://www.mdpi.com/2079-9292/9/6/934>
- [6] G. Biagetti, P. Crippa, L. Falaschetti, S. Orcioni, and C. Turchetti, "Wireless surface electromyograph and electrocardiograph system on 802.15.4," *IEEE Transactions on Consumer Electronics*, vol. 62, no. 3, pp. 258–266, 2016.
- [7] P. Thippun, A. Booranawong, D. Buranapanichkit, and W. Teerapabkajorndet, "An experimental study of dynamic capabilities in a wireless body area network," in *2020 12th International Conference on Knowledge and Smart Technology (KST)*, 2020, pp. 164–167.
- [8] G. L. Cerone, A. Botter, and M. Gazzoni, "A modular, smart, and wearable system for high density sEMG detection," *IEEE Transactions on Biomedical Engineering*, vol. 66, no. 12, pp. 3371–3380, 2019.
- [9] M. Salayma, A. Al-Dubai, I. Romdhani, and Y. Nasser, "Wireless Body Area Network (WBAN): A survey on reliability, fault tolerance, and technologies coexistence," *ACM Comput. Surv.*, vol. 50, no. 1, Mar. 2017. [Online]. Available: <https://doi.org/10.1145/3041956>
- [10] S. Sapienza, P. Motto Ros, D. A. Fernandez Guzman, F. Rossi, R. Terracciano, E. Cordedda, and D. Demarchi, "On-line event-driven hand gesture recognition based on surface electromyographic signals," in *2018 IEEE International Symposium on Circuits and Systems (ISCAS)*, 2018, pp. 1–5.
- [11] P. Motto Ros, B. Miccoli, A. Sanginario, and D. Demarchi, "Low-power architecture for integrated CMOS bio-sensing," in *2017 IEEE Biomedical Circuits and Systems Conference (BioCAS)*, 2017, pp. 1–4.
- [12] P. Motto Ros, A. Sanginario, M. Crepaldi, and D. Demarchi, "Quality-energy trade-off and bio-inspired electronic systems," in *2018 IEEE International Conference on the Science of Electrical Engineering in Israel (ICSEE)*, 2018, pp. 1–5.
- [13] S. Sapienza, M. Crepaldi, P. Motto Ros, A. Bonanno, and D. Demarchi, "On integration and validation of a very low complexity ATC UWB system for muscle force transmission," *IEEE Transactions on Biomedical Circuits and Systems*, vol. 10, no. 2, pp. 497–506, 2016.
- [14] D. A. Fernandez Guzman, S. Sapienza, B. Sereni, and P. Motto Ros, "Very low power event-based surface EMG acquisition system with off-the-shelf components," in *2017 IEEE Biomedical Circuits and Systems Conference (BioCAS)*, 2017, pp. 1–4.
- [15] P. Motto Ros, M. Laterza, D. Demarchi, M. Martina, and C. Bartolozzi, "Event-driven encoding algorithms for synchronous front-end sensors in robotic platforms," *IEEE Sensors Journal*, vol. 19, no. 16, pp. 7149–7161, 2019.
- [16] F. Rossi, A. Mongardi, P. Motto Ros, M. Ruo Roch, M. Martina, and D. Demarchi, "Tutorial: A versatile bio-inspired system for processing and transmission of muscular information," *IEEE Sensors Journal*, pp. 1–1, 2021.
- [17] F. Rossi, P. Motto Ros, R. M. Rosales, and D. Demarchi, "Embedded bio-mimetic system for functional electrical stimulation controlled by event-driven sEMG," *Sensors*, vol. 20, no. 5, 2020. [Online]. Available: <https://www.mdpi.com/1424-8220/20/5/1535>
- [18] A. Mongardi, P. Motto Ros, F. Rossi, M. Ruo Roch, M. Martina, and D. Demarchi, "A low-power embedded system for real-time sEMG based event-driven gesture recognition," in *2019 26th IEEE International Conference on Electronics, Circuits and Systems (ICECS)*, 2019, pp. 65–68.
- [19] S. Aiassa, P. Motto Ros, G. Masera, and M. Martina, "A low power architecture for AER event-processing microcontroller," in *2017 IEEE Biomedical Circuits and Systems Conference (BioCAS)*, 2017, pp. 1–4.
- [20] K. Boahen, "Point-to-point connectivity between neuromorphic chips using address events," *IEEE Transactions on Circuits and Systems II: Analog and Digital Signal Processing*, vol. 47, no. 5, pp. 416–434, 2000.
- [21] P. Motto Ros, M. Crepaldi, C. Bartolozzi, and D. Demarchi, "Asynchronous DC-free serial protocol for event-based AER systems," in *2015 IEEE International Conference on Electronics, Circuits, and Systems (ICECS)*, 2015, pp. 248–251.
- [22] P. Motto Ros, M. Crepaldi, A. Bonanno, and D. Demarchi, "Wireless multi-channel quasi-digital tactile sensing glove-based system," in *2013 Euromicro Conference on Digital System Design*, 2013, pp. 673–680.
- [23] M. Crepaldi, M. Stoppa, P. Motto Ros, and D. Demarchi, "An analog-mode impulse radio system for ultra-low power short-range audio streaming," *IEEE Transactions on Circuits and Systems I: Regular Papers*, vol. 62, no. 12, pp. 2886–2897, 2015.
- [24] S. Al-Sarawi, M. Anbar, K. Alieyan, and M. Alzubaidi, "Internet of Things (IoT) communication protocols: Review," in *2017 8th International Conference on Information Technology (ICIT)*, 2017, pp. 685–690.
- [25] J. Tosi, F. Taffoni, M. Santacatterina, R. Sannino, and D. Formica, "Performance evaluation of bluetooth low energy: A systematic review," *Sensors*, vol. 17, no. 12, 2017. [Online]. Available: <https://www.mdpi.com/1424-8220/17/12/2898>
- [26] Bluetooth SIG Inc. Bluetooth specification version 4.2. Accessed: August 29, 2021. [Online]. Available: <https://www.bluetooth.com/specifications/specs/core-specification-4-2/>
- [27] Bluetooth SIG Inc. Bluetooth core specification v5.0. Accessed: August 29, 2021. [Online]. Available: <https://www.bluetooth.com/specifications/specs/core-specification-5/>
- [28] A. Townsend K., Cufi C., *Getting started with Bluetooth Low Energy. Tools and techniques for low-power networking.*
- [29] Institute of Electrical and Electronics Engineers (IEEE). IEEE Std 802.15.4-2006. [Online]. Available: [https://standards.ieee.org/standard/802\\_15\\_4-2020.html](https://standards.ieee.org/standard/802_15_4-2020.html)
- [30] P. Motto Ros, M. Paleari, N. Celadon, A. Sanginario, A. Bonanno, M. Crepaldi, P. Ariano, and D. Demarchi, "A wireless address-event representation system for ATC-based multi-channel force wireless transmission," in *5th IEEE International Workshop on Advances in Sensors and Interfaces IWASI*, 2013, pp. 51–56.
- [31] R. Navigli and F. Martelli, "An overview of word and sense similarity," *Natural Language Engineering*, vol. 25, no. 6, p. 693–714, 2019.
- [32] S. Ontañón, "An overview of distance and similarity functions for structured data," *CoRR*, vol. abs/2002.07420, 2020. [Online]. Available: <https://arxiv.org/abs/2002.07420>