

Development and initial tests of an urban comfort monitoring system

Original

Development and initial tests of an urban comfort monitoring system / Chiesa, Giacomo; Yingjun, Luo; Yuxuan, Sheng; Guoxin, Wang; Bolun, Zhang. - In: JOURNAL OF PHYSICS. CONFERENCE SERIES. - ISSN 1742-6588. - ELETTRONICO. - 2042:1(2021), pp. 1-6. [10.1088/1742-6596/2042/1/012051]

Availability:

This version is available at: 11583/2938932 since: 2021-11-19T13:43:12Z

Publisher:

IOP Publishing Ltd

Published

DOI:10.1088/1742-6596/2042/1/012051

Terms of use:

This article is made available under terms and conditions as specified in the corresponding bibliographic description in the repository

Publisher copyright

(Article begins on next page)

Development and initial tests of an urban comfort monitoring system

Giacomo Chiesa^{1*}, Luo Yingjun, Sheng Yuxuan, Wang Guoxin, Zhang Bolun

¹Politecnico di Torino, DAD, Viale Pier Andrea Mattioli 39, 10125 Torino, Italy

²Politecnico di Torino, ICT4SS-DET, C.so Duca degli Abruzzi 24, 10129 Torino, Italy

*e-mail: giacomo.chiesa@polito.it

Abstract. The paper presents a newly developed low-cost measurement system for outdoor comfort monitoring. The solution is based on IoT (Internet of Things) technologies and is cloud-connected. The system is able to collect physical environment data, and includes a movable GPS monitoring station as well as the subjective thermal sensation of pedestrians via a devoted app. The cloud interface promptly elaborates the received data to calculate outdoor thermal comfort indices such as UTCI (Universal Thermal Climate Index), MRT (mean radiant temperature), and ET (effective temperature). The system is conceived for supporting both fixed and traveling measurements, and to support correlation studies between monitored environmental variables and personal comfort sensations to promote the local adaptation of comfort indices. Results from early testing are also reported.

1. Introduction

In 2018 the UN predicted that, by 2050, two-thirds of the world population will live in large cities [1], with a consequent rise of the influence that urban boundary conditions have on people's living conditions, spaces, and comfort. The study of urban microclimate issues is an essential challenge to guarantee comfort conditions, the management and mitigation of climate risks (global and local, such as urban heat islands), and the reduction of energy consumption to increase the resilience of our cities, as underlined by a large number of devoted studies – e.g. [2-4].

Outdoor thermal comfort can affect the quality of life of urban inhabitants, including the intensity and the number of outdoor activity hours of citizens in parks, squares, and other locations, and the way of conceiving city travel. Additionally, it is connected to boundary conditions of indoor spaces. Nevertheless, most of the research efforts are directed to indoor comfort, while the study of systematic urban outdoor comfort conditions, including the development of adapted sensor solutions supporting outdoor comfort monitoring campaigns, especially at a low cost, is open to further development. The majority of outdoor monitoring studies are based on adapted PMV-WBGT sensor kits or on weather stations used to define fixed or movable monitoring points. For example, [5] adopts commercial weather stations with wet-bulb globe temperature probes to analyse the effect of different green area settings on outdoor thermal comfort (UTCI). Similarly, [6] performs outdoor comfort analyses based on monitoring and thermal sensations in Eindhoven by adopting surveys and monitoring stations located in different points of the city. An interesting study concerning outdoor comfort mapping was reported in [7]; it combined a movable monitoring station based on professional instruments, an app to collect the thermal



sensations of participants, and manual post-processing of data. The study applied this methodology to the city of Genoa.

Differently, the proposed system is based on the adoption of a low-cost IoT (Internet of Things) solution able to automatically store data through cloud and map results. It includes an app and surveys to collect thermal sensations.

1.1. Paper objectives

The proposed paper aims to establish an efficient and low-cost measurement system to collect physical environment data and subjective thermal sensation of pedestrians by developing an IoT system based on Raspberry Pi and Arduino, which may be used for both movable and fixed monitoring points. This system will allow the collection and processing of collected data to study the relationship between the urban micro-environment and different comfort indices. We established four sub-objectives of this study:

- a. to develop a cloud-connected IoT system that integrates probes to measure air temperature, wet-bulb globe temperature, air velocity, and humidity. A GPS module is included to geo-tag environmental data in real-time;
- b. to develop a mobile application to allow pedestrians to provide subjective data on thermal sensations at each survey point (and, in parallel, a traditional questionnaire);
- c. to calculate different thermal comfort models by elaborating monitored data and visualize results on a map, and to define potential correlations between calculated and perceived data;
- d. to conduct an outdoor comfort measurement in the city of Turin to test the proposed system, including a comparison between results calculated by the IoT system developed and by a PMV professional measurement solution.

The IoT system developed is responsible for environmental parameter collection and for the adjustment and synchronization of sensors. The app development includes front-end design and back-end development, which is conceived as a questionnaire to assist user data collection – during the test, traditional paper-based surveys including the same questions are also used by some participants. A GPS module is added to both the app and the IoT system.

The paper is structured as follows: Section 2 will describe the adopted methodology and the development of the IoT system, Section 3 will report initial tests of the system during a series of “urban treks” including a comparison with a commercial thermal comfort station, while Section 4 is devoted to conclusions.

2. Methodology and system development

This section will describe the IoT system developed and the app defining the adopted comfort models.

2.1. Comfort models

Several comfort models to analyse outdoor comfort conditions have been developed and discussed in literature, e.g. [3,8]. For the purposes of this study, the following outdoor comfort indices were selected: Universal Thermal Index (UTCI) [9,10], developed during the COST Action 730; mean radiant temperature (MRT) – calculated using the well-known ASHRAE expression [11]; and effective temperature (ET) [12]. The system is also able to calculate the predicted mean vote (PMV) – see ISO 7730. Such indices were not natively applied to outdoor spaces, although some applications were underlined [8]. Nevertheless, the proposed system may allow the calculation of additional indices considering the large set of measured variables and its scalability.

2.2. IoT and app system development

According to the selected comfort models, the study developed an IoT micro-weather station system able to measure bulb globe temperature (T_g), air temperature (T_a), air/wind velocity (V_a), relative humidity (RH), and data point coordinates (GPS). The system may be connected to the power grid or powered by battery packs (UNIROI Lithium battery board) supporting a 5V voltage for about 1.5 hours

each to allow outdoor fixed and movable measurement campaigns. Additional power banks are used to guarantee longer autonomies. The micro-weather station is based on a Raspberry Pi 3B+, used to collect data from sensors (with the exclusion of the wind sensor that adopts an Arduino Uno R3 as an intermediate microprocessor). The adopted sensors are shown in Fig. 1 and include the developed frame for backpack portability. The globothermometer is based on a type K thermocouple, positioned in the middle of an acrylic grey globe (38 mm) with a matte grey coating (RAL 7001) to simulate typical skin and clothing values of absorptivity – see [3]. Data are taken every 15 seconds and the measurements are stored in the Raspberry memory in *.csv format. Data are accessible in remote by registered users, as the Raspberry Pi is programmed to act as a server. Remote data from the IoT monitoring kit are hence processed, filtering outliers to exclude irrelevant points, while comfort models are further processed thanks to a tool developed in Python.

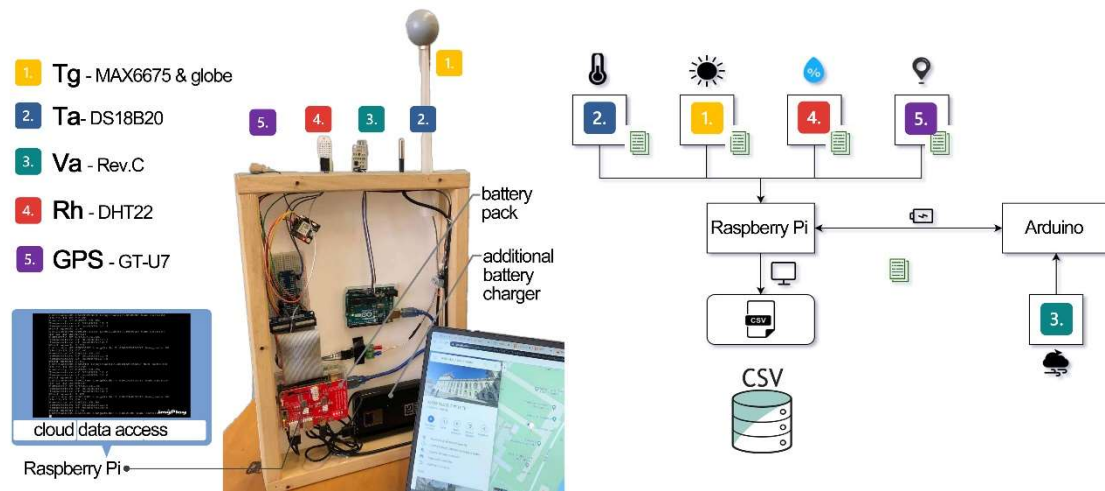

Figure 1. The prototype of the developed kit.

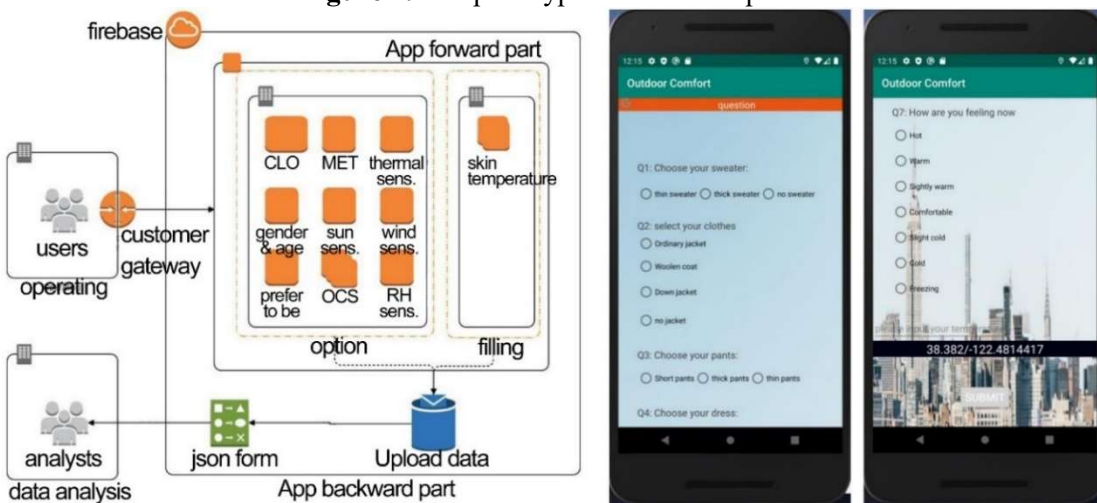

Figure 2. (a) Block diagram of the app structure. (b) General partial overview of the app.

The majority of outdoor comfort surveys to collect user information (e.g. CLO, MET) and thermal sensations are based on paper questionnaires. The proposed approach may use both paper-based surveys or app-based ones. An app was programmed to investigate user information and sensations, including datapoint geotags. The app development includes the definition of User Interface (UI) – see Fig. 2(b), user registration, data collection, geotagging, and cloud data storage database (Firebase using JSON). The block diagram of the app is reported in Fig. 2(a). Table 1 shows the thermal sensation questions included in both the paper and the app questionnaires, which are compatible with previous literature

[7,13]. The app survey data are stored in Firebase and are synchronized with the monitored environmental data considering coordinates and time periods in order to compare user sensations with comfort indices using a developed Python tool. Georeferenced data (monitored and app-retrieved) are hence plotted on maps adopting the Mapbox API, which allows the development of survey and monitoring point mapping processes for data recovery – see section 3.

Table 1. Extract from Subjective scales used in the questionnaire (app and paper-based)

Thermal sensation: how do you feel with respect to heat and cold?						
Very hot	Hot	warm	Neutral	slightly cold	Cold	Very cold
Exposure to the sun: how about exposure to the sun?						
Sun makes me uncomfortable			Just fine	I'd like more sun		
Wind speed: how is the wind-impact on thermal sensation?						
Much too windy	Too windy	Slightly windy	Just ok	Slightly still	Too still	Stagnant
Overall comfort						
Very uncomfortable		Uncomfortable		Comfortable		Very comfortable

3. Data analysis and discussion (early field tests)

Results of an initial field test of the system are reported and based on a series of three “urban treks” following the same path around downtown Turin (Italy) at different hours of the day (morning, afternoon, night). Firstly, monitored data from the IoT system and from surveys (both using the app and printed questionnaires) were collected and automatically processed and mapped thanks to the involvement of about 20 people during an international summer school. Secondly, early correspondences between comfort indices and thermal sensations were shortly discussed. Finally, an early comparison test between the IoT kit and a professional thermal comfort station, monitoring the same environmental variables (temperature, humidity, air velocity, bulb globe temperature, with the addition of solar radiation) was performed.

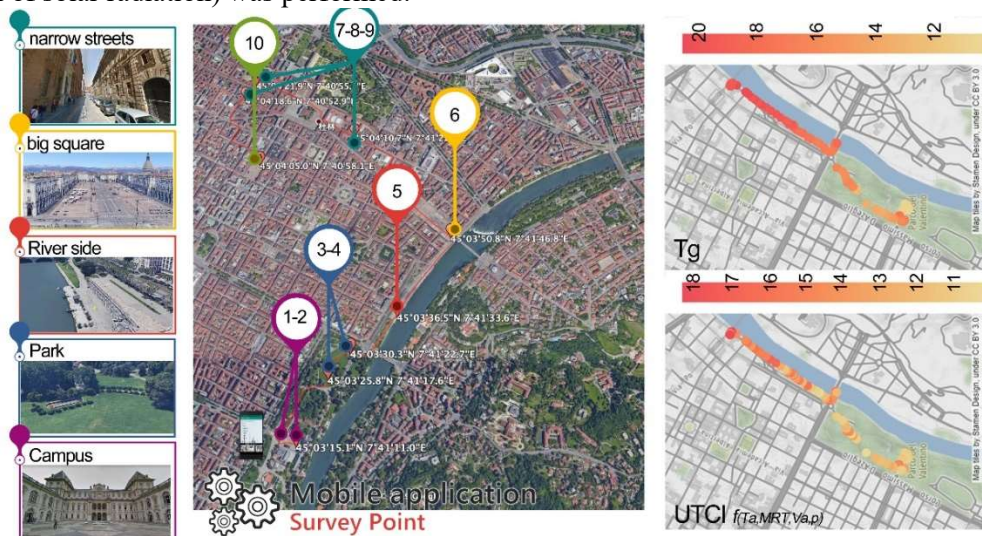

Figure 3. (a) TS collection points (app and printed surveys). (b) sample maps elaborated during the path based on data transmitted by the IoT kit

Fig. 3 (a) shows the distribution of points in which thermal sensations (TS) of people (of different ages and genders) involved are retrieved after a stay lasting about 20-30 minutes (adaptation time).

Differently, the monitoring IoT system recorded the data along the whole walking path. Fig. 3(b) reports some of the maps automatically elaborated through Mapbox API.

3.1. Correlation analysis (comfort KPIs vs. sensation votes)

A comparison between the calculated comfort KPIs based on the monitored data and the TS votes was performed using the Python code developed for data synchronization. Fig. 4 shows the retrieved associations including regression lines with intervals – dots represent the average TS in each set of datapoints, while intervals are based on the whole dataset. Results show good correlations for all considered indices (ET, UTCI, PMV), even if a larger survey pool is expected in the following research step.

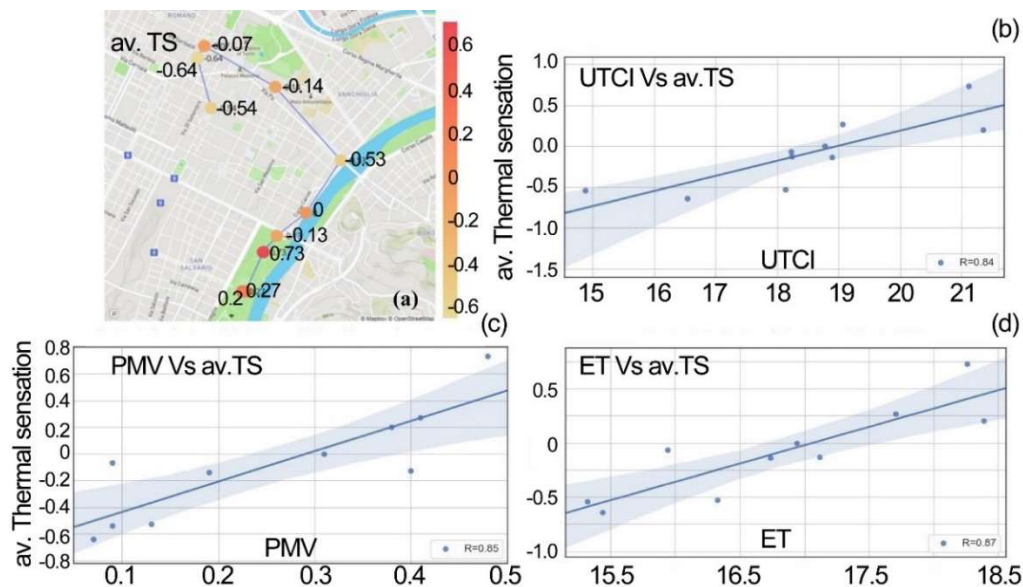

Figure 4. (a) average TS in each location; Scatter plots comparing TS and thermal comfort KPIs – (b) UTCI, (c) PMV, (d) ET

3.2. Result comparisons with professional instruments

The IoT-monitored data were also compared with data retrieved by a professional thermal comfort monitoring station (Testo 480 with Testo probes and a Delta OHM pyranometer C1.2) adapted to be mounted on a portable bag to measure data during the treks in parallel with the IoT system. An extract of results and data processed are shown in Fig. 5. Both monitoring solutions report a similar path in measurements with slight discrepancies. By plotting Testo data as a function of IoT data (same time) both T_a and T_g show very high coefficients of determination (R^2 is respectively 0.8 and 0.9), while RH is more scattered (R^2 0.67). Nevertheless, even higher R^2 results are retrieved when instantaneous data are averaged over 5-minute intervals. Coefficients of determination are 0.94 for T_a , 0.97 for T_g , and 0.92 for RH. Differently, wind velocity values show a very limited correlation for instantaneous values ($R^2=0.2$), the coefficient of determination at 5-minute average values rises to 0.77, as expected given instantaneous air velocity is subject to fast variations, especially in open spaces. UTCI values have an R^2 of 0.47 and 0.71 respectively for instantaneous and 5-min average values. Mean Absolute Errors for instantaneous values are 0.46°C for T_a (lower than sensor accuracy), 2.36°C for T_g , 9% for RH, 0.6 m/s for wind velocity, and 0.21 for UTCI. Focusing on T_g , the relevant RAE is nevertheless very similar to the retrieved RMSE of 2.5°C, confirming that the two sensors show similar trends – a very high R^2 – but shifted by 2.4°C. A re-calibration of the thermocouple will be considered (e.g. for this set it would bring the RMSE to 0.8).

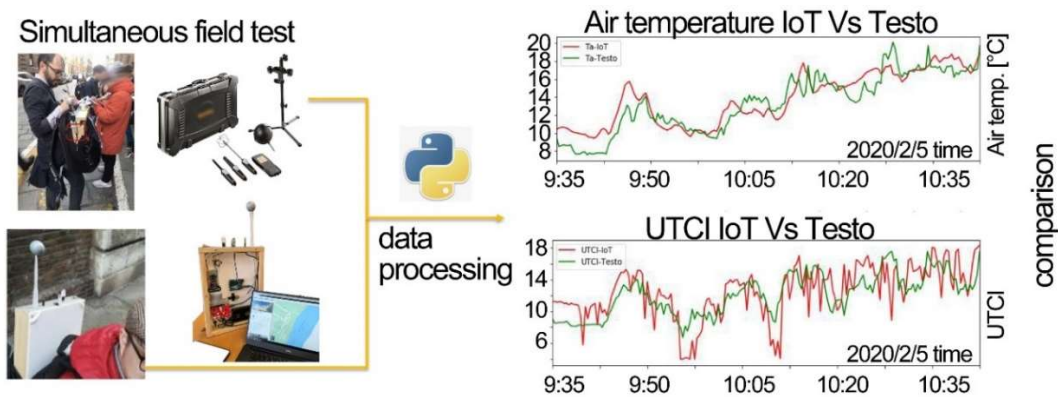

Figure 5. Early-comparison between IoT and Testo results

4. Conclusions

The paper reports an initial description of an IoT low-cost monitoring system able to define georeferenced outdoor comfort KPIs and a correlated app to retrieve the thermal sensations of users. Data were cloud-stored and different KPIs were automatically calculated and plotted on maps. The system is conceived to be further expanded by adding extra probes and KPIs, while at present it has reached a technological readiness level (TRL) of 3. Results of an initial monitoring campaign are reported to test the system and show its basic functionalities. During the first comparison with data monitored by a commercially available scientific station, the IoT system shows high R^2 values especially for 5-minute average data, while error analyses suggest that T_g may benefit from a linear re-calibration. Nevertheless, the proposed system has a high potential for future development, considering its scalability, its high adaptation and personalization potential, the cloud data-transmission with end-user interfaces, and the low cost (one order of magnitude lower). These outcomes suggest that the proposed system may be applied when a large number of monitoring points are required and when the portability of the system is needed due to its lightweight. Further developments are planned, including additional tests on different use scenarios and a larger survey to work on local correlations between TS and environmental variables including outdoor comfort KPIs.

Acknowledgments

Project development was co-funded by the 59_ATEN_RSG16CHG and 59_IG_SUMMER20_CHS University Grants. We thankfully acknowledge Prof. Dovis – Master’s Degree in ICT4SS for his precious suggestions.

References

- [1] UN 2018 *World Urbanisation Prospects: the 2018 revision*, UN, NY
- [2] Ng E (ed) 2010 *Designing high-density cities*, Earthscan, London
- [3] Erell E, Pearlmutter D, Williamson T 2011 *Urban microclimate*, Routledge, Abingdon
- [4] Chiesa G (ed) 2021 *Bioclimatic approaches in urban and building design*, Springer, Cham
- [5] Petralli M et al 2020 *Regional Studies on development* **24**(3) 111-117
- [6] Peng Y et al 2019 *Building and Environment* **148** 459-467
- [7] Chokhachian A et al 2018 *Journal of Building Engineering* **20** 94-104
- [8] Cocco S et al 2016 *Urban Climate* **18** 33-57
- [9] Błażejczyk K et al 2013 *Geographia Polonica* **86**(1) 5-10
- [10] Broede P 2009 *Program for calculating UTCI temperature*, available at utci.org, last view 4/21
- [11] Thorsson S et al 2007 *Int. J. Climatol.* **27**(14) 1983-1993
- [12] Roi Choudhury AK 2011 Factor effecting comfort *Improving comfort cooling* ed G Song 3-60
- [13] Givoni B 2010 Thermal comfort issues and implications in high-density cities *Designing high-density cities* ed Ng 87-106