

A Data-Driven Approach to Autonomous Management of Photonic Switching System

*Original*

A Data-Driven Approach to Autonomous Management of Photonic Switching System / Khan, Ihtesham; Masood, Muhammad Umar; Tunesi, Lorenzo; Ghillino, Enrico; Bardella, Paolo; Carena, Andrea; Curri, Vittorio. - ELETTRONICO. - (2021), pp. 1-2. (Intervento presentato al convegno IEEE Photonics Society Summer Topicals Meeting Series (SUM) tenutosi a Cabo San Lucas, Mexico nel 19-21 July 2021) [10.1109/SUM48717.2021.9505780].

*Availability:*

This version is available at: 11583/2917842 since: 2021-08-15T14:41:49Z

*Publisher:*

IEEE

*Published*

DOI:10.1109/SUM48717.2021.9505780

*Terms of use:*

openAccess

This article is made available under terms and conditions as specified in the corresponding bibliographic description in the repository

*Publisher copyright*

IEEE postprint/Author's Accepted Manuscript

©2021 IEEE. Personal use of this material is permitted. Permission from IEEE must be obtained for all other uses, in any current or future media, including reprinting/republishing this material for advertising or promotional purposes, creating new collecting works, for resale or lists, or reuse of any copyrighted component of this work in other works.

(Article begins on next page)

# A Data-Driven Approach to Autonomous Management of Photonic Switching System

Ihtesham Khan  
*DET, Politecnico di Torino, Italy,*  
 ihtesham.khan@polito.it

M Umar Masood  
*DET, Politecnico di Torino, Italy,*  
 muhammad.masood@polito.it

Lorenzo Tunesi  
*DET, Politecnico di Torino, Italy,*  
 tunesi.lorenzo@gmail.com

Enrico Ghillino  
*Synopsys, Inc., 400, United States.*  
 enrico.ghillino@synopsys.com

Paolo Bardella  
*DET, Politecnico di Torino, Italy*  
 paolo.bardella@polito.it

Andrea Carena  
*DET, Politecnico di Torino, Italy,*  
 andrea.carena@polito.it

Vittorio Curri  
*DET, Politecnico di Torino, Italy*  
 curri@polito.it

**Abstract**—We propose a data-driven approach based on Machine Learning (ML) to predict control signals of a photonic switching system. The proposed ML agent is trained and tested in a completely topological and technological agnostic way and we envision its application in real-time control-planes.

**Index Terms**—Data-Driven Science, Machine Learning, Optical Switches, Photonic Integrated Circuits.

## I. INTRODUCTION

Nowadays, network components are extensively exploiting PICs to perform complex functions at the photonic level, avoiding the bottleneck of opto-electronic conversion. PICs are a promising technology for next generation of photonic switches systems due to their low energy consumption, lower latency and small foot-print. These attributes of photonic switching systems suggest a large adoption in future core optical networks and data centers, allowing dynamic provisioning to satisfy connection requests. This progressively increasing trend requires an automatic management of PIC-based switching devices as their complexity will increase. In this scenario, Software defined networking (SDN) becomes an important paradigm for the softwarized and autonomous management of photonic switches based on PICs.

Typically, PIC based switches rely internally on elementary  $2 \times 2$  cells such as Mach-Zehnder interferometers switches (MZI) or optical Micro ring resonators based filters (MRR). The flow of light inside these building units can be routed to different paths by an electrical control signal [1], [2]. Given a  $N \times N$  switch, control signals can be represented by a binary vector of  $M$  elements, where  $M$  is the number of elementary  $2 \times 2$  blocks. When  $M_i = 1$ , the  $i$ -th individual switch element is set to cross condition ( $[0, 1] \rightarrow [1, 0]$ ) while for  $M_i = 0$  it is set to bar condition ( $[0, 1] \rightarrow [0, 1]$ ). The considered generic switch structure and application is depicted in Fig. 1: by varying the  $M$  control signals, the  $N$  input signals can be routed to the output ports ordered as any possible permutation. These  $2 \times 2$  switches can be interconnected according to different topologies to obtain a

$N \times N$  transparent switch. Each topological configuration is characterized by some special properties: collision avoidance among the input channels, minimization of optical losses, planarity, reduction of the circuit footprint and of the operational power consumption [3]. Most optical non-blocking switching networks shown in the literature are based on the Banyan switch or the Clos network: they can be described as multi-stage crossover switches obtained through a  $2 \times 2$  base element, with alternating stages of differently arranged switches and interconnect crossings. Starting from these general topologies, through optimization and substitution of elements inside the network, ad-hoc optimized configurations can be obtained.

The Honey-Comb Rearrangeable Optical Switch (HCROS) [4], is an example of these type of switches. With respect to traditional topological implementations [5], this network shows an overall less regular structure, as well as stage asymmetry, typically absent in traditional switching networks. As for any crossbar-based network, the number of available unique control signals correspond to  $2^M$ , while, given the non-blocking property, each of the  $N!$  unique permutations of the  $N$  input signals is achievable. The original  $6 \times 6$  HCROS has been expanded to a  $12 \times 12$  structure, to increase its complexity to a non-trivial case for ML approach. Deterministic algorithms can efficiently calculate the control states of the internal switches to obtain the requested signals permutation, unfortunately each algorithm is specifically designed for the

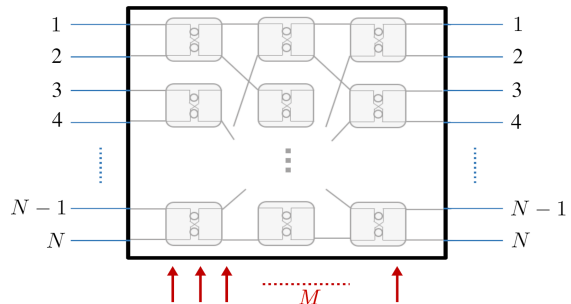

Fig. 1: Generic  $N \times N$  optical switch fabric.

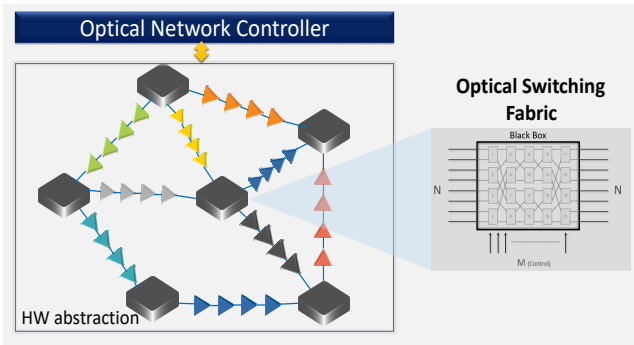

Fig. 2: Software-defined Open Optical Networks.

internal topology of the network, and no general-purpose algorithm exists [3] with a reasonable and scalable computational cost.

In this work, we propose to train a topology agnostic machine learning (ML) agent to predict control signal states. The proposed approach is adopted in the context of a SDN: we introduce the concept of a softwarized and autonomous configuration of any PIC based optical switching system depicted in Fig. 2. Given a  $N \times N$  photonic switch with arbitrary, and potentially unknown, internal structure, the proposed technique assumes it as a black-box component and it efficiently allows to determine control states with accuracy exceeding 97%.

## II. ML FRAMEWORK, RESULTS AND CONCLUSION

To generate the ML training and testing dataset, we considered a  $N \times N$  HCROS switch. A subset of the total  $2^M$  control combinations is used for the generation of the dataset, as reported in Tab. Ia. The dataset is used to train a supervised neural network in the learning phase. The proposed ML model, explicitly a deep neural network (DNN), is developed by using TensorFlow<sup>®</sup> platform: it incorporates *three hidden-layers* with 35 neurons for each hidden layers. The proposed DNN model exploited *ReLU* as activation function and it is evaluated by mean square error (MSE) as loss function. The DNN model is configured for training-steps of 1,000 and learning-rate of 0.01. The train set for  $12 \times 12$  HCROS topology consists of 70% of the dataset, while the test set consists of 30% of dataset, as reported in Tab. Ia. Furthermore, the proposed ML agent exploit the different combination of wavelengths at the output ports as features and  $M$  control signals as labels.

The effect of various ML parameters, especially the increase of the hidden-layer size of the proposed DNN model, is analyzed in terms of single ring training time depicted in Fig. 3a, for a an Intel<sup>®</sup> Core<sup>™</sup> i7 6700 3.4 GHz CPU workstation equipped with 32 GB of 2133 MHz RAM. The results reveal that the single switching unit training time linearly increases with increasing the number of neurons per hidden-layer. Along with this, the effect of increasing the number of neurons per hidden-layer is also shown in Fig. 3b as an improvement in the prediction ability of ML model, up to certain extent, after which it remains constant. Finally in Fig. 3c, the effect of the total considered training data size reported in Tab. 1 is

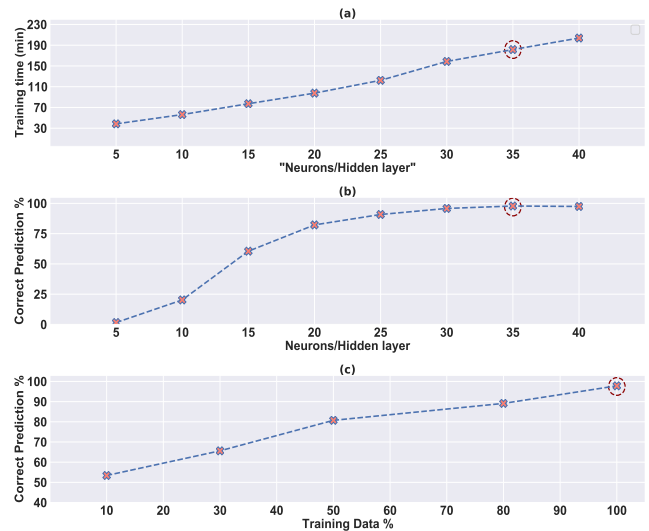

Fig. 3: Neural Network Analysis.

also revealed. The trend shows that the prediction ability of ML model improves with the increasing training data size. The encircled values reported in Fig. 3 are considered for developing the cognition in DNN engine. Promising results are achieved with the considered HCROS topology, as reported in Tab. Ib. and an excellent level of accuracy (>97%) is achieved.

To improve the prediction capabilities of the ML approach, we added an auxiliary step based on a simple heuristic that we derived from observing wrong configurations. The majority of errors in the prediction of the control state are due to a single switch element in the incorrect state. The heuristic we propose is to simply try the correction of single switch errors by flipping one switch at a time and comparing the output sequence against the desired output. For HCROS, using ML assisted by heuristic the accuracy improves to 100%.

In conclusion, we have demonstrated that a ML approach can effectively determine control states for a generic  $N \times N$  photonic switch without any knowledge required on the topology. The ML is scalable to large  $N$  as we show high level of accuracy with limited size dataset.

TABLE I: Dataset and results for a  $12 \times 12$  HCROS network. (a) Dataset Statistics (b) ML prediction results

<b>Permutations (<math>N!</math>)</b>	$4,79 \times 10^6$	<b>Neurons / hidden layer</b>	35
<b>Switches (<math>M</math>)</b>	36	<b>Accuracy (no heuristic)</b>	97.83%
<b>Combinations (<math>2^M</math>)</b>	$68 \times 10^9$	Single ring error	2.17%
<b>Dataset</b>	$3 \times 10^5$	Multiple rings error	0%
<b>Training set</b>	210,000	<b>Accuracy (with heuristic)</b>	100%
<b>Test set</b>	90,000		

## REFERENCES

- [1] E. Ghillino et.al, "Assessing the impact of design options for an optical switch in network routing impairments," in *21st ICTON*, (2019), pp. 1–4.
- [2] I. Khan et.al, "Machine learning assisted abstraction of photonic integrated circuits in fully disaggregated transparent optical networks," in *22nd ICTON*, (2020), pp. 1–4.
- [3] S. Arora et.al, "On-line algorithms for path selection in a nonblocking network," in *Proceedings of the twenty-second annual ACM symposium on Theory of computing*, (1990), pp. 149–158.
- [4] M. Yahya et.al, "Honeycomb ROS: A  $6 \times 6$  non-blocking optical switch with optimized reconfiguration for ONoCs," *Electronics* **8**, 844 (2019).
- [5] R. A. Spanke and V. E. Benes, "N-stage planar optical permutation network," *Appl. Opt.* **26**, 1226–1229 (1987).