

Fast and accurate estimation of fuel-optimal trajectories to Near-Earth Asteroids

Original

Fast and accurate estimation of fuel-optimal trajectories to Near-Earth Asteroids / Mascolo, Luigi; DE IULIIS, Alessia; Casalino, Lorenzo. - In: ACTA ASTRONAUTICA. - ISSN 0094-5765. - ELETTRONICO. - 188:(2021), pp. 49-56. [10.1016/j.actaastro.2021.07.013]

Availability:

This version is available at: 11583/2914684 since: 2021-07-23T09:13:30Z

Publisher:

Elsevier

Published

DOI:10.1016/j.actaastro.2021.07.013

Terms of use:

This article is made available under terms and conditions as specified in the corresponding bibliographic description in the repository

Publisher copyright

(Article begins on next page)

Fast and Accurate Estimation of Fuel-Optimal Trajectories to Near-Earth Asteroids

Luigi Mascolo^a, Alessia De Iuliis^a, Lorenzo Casalino^{a,*}

^a*Politecnico di Torino, Department of Mechanical and Aerospace Engineering, Corso Duca degli Abruzzi, 24, Torino, 10129, Italy*

Abstract

This paper proposes an improved method for the preliminary evaluation of minimum-propellant trajectories to Near-Earth Asteroids (NEAs). The method applies to missions from Earth to asteroids with small eccentricity and inclination. A planar and a plane-change problem can be distinguished. In the planar problem, the solution assumes that multiple burn arcs are performed in correspondence of the apsides of the target asteroid in order to change the initial spacecraft orbit (i.e., Earth's orbit) into the target one. The number of arcs is established once the time of flight is given (1 burn at each apsis per revolution, 1 revolution per year can be assumed). The length and propellant consumption of each arc to attain the required changes of semi-major axis and eccentricity are computed by a procedure based on Edelbaum's approximation, which is well-suited to the problem at hand, as eccentricity changes are expected to be small for feasible missions. No numerical integration is required, but only the numerical solution of a three-unknown algebraic system is needed, making the procedure extremely fast. Plane change is taken into account assuming a constant out-of-plane thrust angle during each burn. A previous simple formulation used an averaged thrust effect over one revolution and neglected the fact that plane changes are more effective at the nodes. Several improvements are here introduced, which greatly increase the method accuracy. The influences of the eccentricity change, the angle between the asteroid line of nodes and line of apsides, and the expected length of the arc are considered: In fact, when the eccentricity is small, the thrust arc can be performed at the nodes where the inclination is efficiently changed, with little penalty in the planar maneuver. An efficient plane change is also performed when the angle between the asteroid line of nodes and line of apsides is small and/or the length of the arc is large, because, in this case, the node is comprised in the apsidal burn. A simple corrective formula accounts for this effect. The new method shows remarkable accuracy. The results comparison with solutions obtained with an indirect op-

*Corresponding author

Email addresses: luigi.mascolo@polito.it (Luigi Mascolo),
alessia.deiuliis@polito.it (Alessia De Iuliis), lorenzo.casalino@polito.it (Lorenzo Casalino)

timization method for a set of more than 60 NEAs shows a 0.95 correlation coefficient in the propellant masses. The estimation error is below 10% for 75% of the targets, below 15% for 95% of the targets, and always below 20%.

Keywords: Near-Earth Asteroids - Trajectory Optimization - Edelbaum Approximation - Electric Propulsion

Nomenclature

a	=	semi-major axis, AU
c	=	effective exhaust velocity, m/s
e	=	eccentricity
e_x, e_y	=	eccentricity vector components
i	=	inclination, deg
K	=	correction factor
k_0, k_1, k_2, k_3	=	correction parameters
m	=	mass, kg
m_p	=	propellant mass, kg
n	=	number of revolutions
r	=	radius, AU
r_a	=	aphelion radius, AU
r_p	=	perihelion radius, AU
Ω	=	right ascension of the asc. node, deg
T	=	thrust, N
α	=	in-plane thrust angle, deg
β	=	out-of-plane thrust angle, deg
$\Delta i_{2\pi}$	=	1-rev. inclination change, deg
Δm	=	propellant consumption error, kg
ΔPA	=	total propulsive effort at perihelion
ΔAP	=	total propulsive effort at aphelion
Δt	=	burn arc time length, s
ΔV	=	velocity increment, m/s
$\Delta \vartheta$	=	burn arc angular length, deg
Λ	=	control law coefficient
ϑ	=	right ascension, deg
ϑ_e	=	reference right ascension, deg
Ω	=	argument of periapsis, deg

Subscripts

0	=	initial
AP	=	aphelion maneuver
avg	=	average
E	=	Earth
PA	=	perihelion maneuver
$R.23$	=	results of Ref. 23
ref	=	reference value
T	=	target

1. Introduction

Electric Propulsion (EP) is a realistic and serious alternative to chemical propulsion. The large specific impulse of EP enables missions that would require prohibitive amounts of propellant with chemical propulsion. EP is limited by the available electric power onboard the spacecraft; hence it is suitable for low-thrust long-duration missions. For these reasons, the use of EP, in particular ion propulsion, has already been adopted for different missions aimed at Near-Earth asteroids (NEAs), such as Hayabusa to (25143) Itokawa [1] and Hayabusa 2 to (162173) Ryugu [2], and at main-belt asteroids, such as DAWN [3], which reached (4) Vesta and (1) Ceres. The use of ion propulsion for NEAs exploration is the object of this paper.

NEAs are asteroids with a perihelion distance of less than 1.3 AU. Their scientific interest lies in their status as unchanged remnant debris from the solar system formation process. Furthermore, they give the possibility to observe specific features not accessible in planets and, in the future, they could also be exploited for their raw materials [4, 5]. Given their proximity with the Earth, missions to many NEAs require low ΔV and propellant consumption. Up to date, a large number of NEAs are already known, and this set is constantly growing as a result of new objects' discoveries. Such a broad set of targets provides opportunities for different scientific missions to new objects.

Usually, direct and indirect methods are employed for the optimization of low-thrust space trajectories [6], whereas evolutionary algorithms are less used and less viable methods for these problems. The main issue, when a large set of targets is considered, is that the trajectory optimization for the entire set could be extremely demanding and time-consuming. Preliminary estimation methods can be employed for an initial selection of the most promising targets and reduce the computational burden related to the optimization process. The availability of an accurate estimation of the transfer cost enables the identification of the most attractive targets (in terms of dynamics), and an exact optimization can be performed only for the most promising ones.

In a recent paper Mereta and Izzo [7] compared the accuracy of several estimation techniques. The authors used the European Space Agency mission M-ARGO, aimed at rendezvous with a NEA with the use of EP, as a case study for these comparisons. In particular, they considered exact solutions obtained with a direct optimization method based on a nonlinear programming approach as a benchmark. Two different propulsion systems (i.e., nuclear and solar EP) were considered. These nominally exact results were compared to solutions obtained considering a two-impulse transfer (Lambert's problem solution) and three-impulse trajectories. Results show a good general accuracy of the different approximations, but also a certain degree of unpredictability, with some estimation errors up to 30%.

Several preliminary estimation methods have been presented in the literature, using different approximation levels that affect the accuracy of the results.

Two-impulse multiple-resolution and three-impulse transfers, using Lambert’s problem solution, can be considered the fastest and easiest method to approximate the cost of a transfer. Low-fidelity models, used to allow for closed-form integration with a state variables representation using Chebychev polynomials [8] and shape-based methods [9, 10] are characterized by increased complexity and consequent improved estimation capabilities. Shape-based methods have thoroughly been used [11, 12, 13, 14, 15] to preliminary design missions to NEAs (among other targets, such as comets and planets), usually in conjunction with more sophisticated refinement methods (e.g., analytic expansion and nonlinear programming solvers). They showed great versatility, as they can be applied to different problems and asteroid classes, and good accuracy: average errors slightly above 10% were, for instance found in Ref. [14] for rendezvous missions to NEAs in comparison to exact solutions. Perturbation theory was used in Refs. [16, 17] to approximate low-thrust transfers and estimate both transfer cost and control laws; they usually require discretization of the trajectory and relatively large sets of unknowns (several tens) resulting in very high accuracy but relatively large computational times (from several seconds to minutes per trajectory). As an alternative, semi-analytical methods based on large databases of pre-computed trajectories to several targets have also been employed [18, 19]. However, these methods are not specifically developed for NEAs. More recently, artificial neural networks and machine learning [20, 21] have also been proposed for the estimation of transfers to NEAs, and showed very encouraging results.

This Article presents an alternative to these approaches. The method is suited for the analysis of low-thrust, multiple-revolution, minimum-fuel transfers between orbits, which, as in Edelbaum’s approximation [22], have small changes of semi-major axis, eccentricity, and inclination. It was specifically developed to deal with rendezvous transfers from Earth to the most accessible NEAs, but can be employed also for transfers between asteroids when the above-mentioned three orbital elements are similar, either NEAs or in the Main Belt.

This method applies to small eccentricity and inclination changes with the use of low thrust, as in Edelbaum’s approximation [22]. No integration of the equations of motion is required since the approach produces a set of algebraic equations, which is numerically solved to determine the mission cost. The low computational complexity (two simple three-variable algebraic systems must be solved to define a transfer) is combined with higher accuracy compared to methods with similar complexity, such as, multiple-revolution Lambert’s problem or three impulse transfers. The computational time is drastically reduced and the preliminary evaluation of large sets of possible targets is quick and accurate. The proposed approach is based on Edelbaum solution for continuous thrusting, and it is adapted to the analysis of NEAs minimum-fuel trajectories with EP (with coast arcs). An initial version of the method was recently presented in Ref. [23], where the solution accuracy was similar to the other simple approximate methods treated in [7]. In the present Article, the method is revised with the introduction of correction factors that take the geometry of the transfer problem into account. The estimation accuracy is greatly improved compared

to the previous work [23] and the existing algebraic methods commonly used in transfer estimation [7], while the computational cost, even though machine and implementation dependent, is similar.

The estimation accuracy is greatly improved compared to the previous work and the other existing methods with comparable computational cost. Section 2 presents the basic guidelines to define the sequence of burns. Section 3 presents the solution of the planar problem, and Section 4 integrates the out-of-plane problem into the planar solution. Section 5 presents and discusses the results.

2. Trajectories to NEAs

Both the ΔV and propellant cost of a mission to reach a NEA are strongly related to the required changes in the orbital parameters from the starting orbit to the target one. Asteroids that require significant changes of eccentricity and inclination with respect to the departure orbit, e.g., Earth's one, are selected as mission objectives only when they present unique characteristics to justify the significant cost, such as (433) Eros reached by the NEAR spacecraft [24]. With few exceptions, the vast majority of asteroids considered for science missions are those characterized by small changes of eccentricity and inclination with respect to Earth's reference orbit. Indeed, favorable targets have semi-major axes close to 1 AU, and small to null eccentricities and inclinations. Therefore, the present research develops a method to approximate the cost of transfers to the most easily reachable NEAs, namely those characterized by almost circular orbits with little inclination.

A preliminary analysis is carried out to define which kind of orbit modifications are required and, consequently, a suitable sequence of burns. The planar problem is considered in this phase, whereas inclination changes will be addressed in Section 4. Earth is the departure planet and a circular orbit with 1-AU radius is initially assumed ($a_E = 1$ and $e_E = 0$). The most straightforward transfer is accomplished with two in-plane impulsive maneuvers that modify perihelion and aphelion to attain the target values. A perihelion impulse provides $r_a = a_T(1 + e_T)$, whereas an aphelion impulse produces $r_p = a_T(1 - e_T)$. These two impulses, in opposition to one another and aligned with the line of apsides of the target, accomplish the required orbit changes by causing specific semi-major axis and eccentricity variations, Δa and Δe . One can easily obtain the required orbital elements change at the perihelion to modify the aphelion radius (PA) and at the aphelion to modify the perihelion radius (AP), which are

$$\Delta a_{PA} = \Delta e_{PA} = [(a_T - 1) + e_T]/2 \quad (1)$$

$$\Delta a_{AP} = -\Delta e_{AP} = [(a_T - 1) - e_T]/2 \quad (2)$$

It is worth noting that Eqs. (1) and (2) assume that the impulses are both applied at 1 AU from the Sun. In the real case, the second impulse is applied at a different radius, as the first one has modified the apsidal distance. These effects are neglected here for the sake of simplicity, as the expected accuracy

improvements are deemed too small to justify the additional complexity. The cost of each maneuver is therefore not influenced by the previous ones: a single evaluation of the burn effect can be used for all the maneuvers performed at one apsis, instead of performing separate evaluations.

A chemical propulsion system can perform the impulses required to achieve the target orbit. Given that EP is used here, the low thrust provided by the propulsion system could achieve the required orbital changes only with long thrusting arcs. In this case, however, the thrust effect is spread among different orbital positions and becomes less effective than the impulse placed at the most favorable one (i.e., the apsis). A single burn may not even be capable of providing the required changes. This problem is solved if sufficient time is available and more revolutions are performed: Each maneuver is equally split into smaller burns with a shorter duration, conveniently placed close to the line of apsides.

The targets considered in this paper have revolution periods of about 1 year. In this case, a mission with a trip time close to n years usually has n passages through the apsides, allowing for n equal perihelion burns and n equal aphelion burns. Each burn must therefore provide a fraction $1/n$ of the total semi-major axis and eccentricity change. Again, the effect of previous burns on the following ones is neglected.

The eccentricity vector, with e_x and e_y components on the ecliptic plane, is introduced to assure the proper alignment of the line of apsides. In particular, by projecting along reference directions x and y the eccentricity vectors of Earth and target, one has

$$\Delta e_x = e_T \cos(\Omega_T + \omega_T) - e_E \cos(\Omega_E + \omega_E) \quad (3)$$

$$\Delta e_y = e_T \sin(\Omega_T + \omega_T) - e_E \sin(\Omega_E + \omega_E) \quad (4)$$

The values Δa and Δe are introduced taking the Earth's actual orbit into account

$$\Delta a = a_T - a_E \quad (5)$$

$$\Delta e = \sqrt{\Delta e_x^2 + \Delta e_y^2} \quad (6)$$

In the n burns scenario, the following changes of orbital elements must be attained: For each perihelion maneuver, one has

$$\Delta a_{PA} = (\Delta a + \Delta e)/(2n) \quad (7)$$

$$\Delta e_{PAx} = \Delta a_{PA}(\Delta e_x/\Delta e) \quad (8)$$

$$\Delta e_{PAy} = \Delta a_{PA}(\Delta e_y/\Delta e) \quad (9)$$

and, for aphelion maneuvers,

$$\Delta a_{AP} = (\Delta a - \Delta e)/(2n) \quad (10)$$

$$\Delta e_{APx} = -\Delta a_{AP}(\Delta e_x/\Delta e) \quad (11)$$

$$\Delta e_{APy} = -\Delta a_{AP}(\Delta e_y/\Delta e) \quad (12)$$

The necessary contributions to change the eccentricity vector and achieve the proper direction, at the perihelion or at the aphelion, are proportional to the semi-major axis variations imposed at the same locations.

3. Planar Problem

Section 2 has defined the orbital changes that must be provided by each burn. The evolution of the orbital elements under the influence of thrusting can be described by Gauss planetary equations[25]. Edelbaum's approximation [22] considers almost circular orbits and small inclination in addition to small thrust, and is perfectly suited to the targets of interest in this article. In nondimensional form the relevant equations are

$$V \frac{da}{dt} = 2a(T/m) \cos \alpha \cos \beta \quad (13)$$

$$V \frac{de}{dt} = 2(T/m) (\cos \vartheta \cos \alpha \cos \beta + \sin \vartheta \sin \alpha \cos \beta) \quad (14)$$

$$V \frac{di}{dt} = (T/m) \cos \vartheta \sin \beta \quad (15)$$

The thrust direction must be properly controlled during each burn to minimize the propellant consumption while performing the required change of orbital elements. The in-plane thrust angle α and the out-of-plane angle β are introduced to express the in-plane thrust component along the radial direction as $T \sin \alpha \cos \beta$, along the velocity direction as $T \cos \alpha \cos \beta$, and the out-of-plane component as $T \sin \beta$.

The planar case considers only semi-major axis and eccentricity; a minimum-time problem can be solved with an indirect approach and the optimal control law for a simultaneous change of semi-major axis and eccentricity can be expressed as a function of two parameters, namely, ϑ_e and λ , which are related to line of apsides position and relative magnitudes of changes in eccentricity and semi-major axis [26]. The optimal control angle α is shown in figure 1 as a function of the angular position with respect to ϑ_e for different values of λ . Two solutions exist at each point, which differ by 180 degrees. The values of the parameters and the solution that must be selected are implicitly determined by the problem

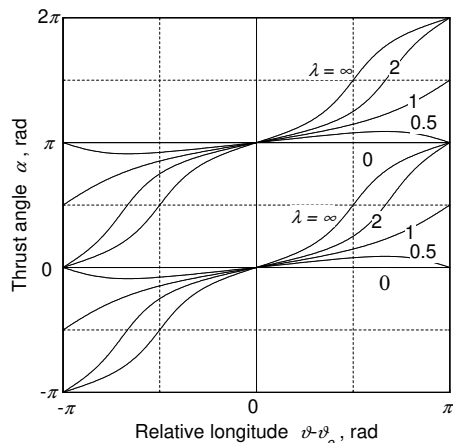

Figure 1: Optimal control law in Edelbaum's planar problem.

boundary conditions. However, the orbital elements equations cannot be analytically integrated with the optimal control law and numerical integration or the use of elliptic integrals is required.

The optimal curve do not differ significantly from a linear trend, and a linear control law [26] that approximates the optimal one is adopted here. In particular, either $\alpha = \Lambda(\vartheta - \vartheta_e)$ or $\alpha = \pi + \Lambda(\vartheta - \vartheta_e)$, depending on the sign of Δa , provide a good approximation by properly selecting Λ and using the same ϑ_e of the exact solution. The angle $\vartheta = \vartheta_e$ corresponds to the point where the thrust is either concurrent with (for $\Delta a > 0$) or opposite to (for $\Delta a < 0$) the spacecraft velocity, with $\alpha = 0$ or π , respectively. Thrust remains close to the velocity direction when Λ , which varies between 0 and 1, is small. Large values of Λ see more significant variations of the thrust direction.

The linear control law allows for analytical integration and provides three equations [26] that relate the required changes Δa , Δe_x , and Δe_y to Λ , ϑ_e , and the burn angular length $\Delta\vartheta_e$. The relations involve the in plane acceleration, that is, spacecraft mass and, in the complete problem, out-of-plane thrust angle β . The burn evaluation is thus turned into a simple three-variable algebraic system, which is easily solved with an iterative procedure. Tentative values are assumed for Λ , ϑ_e , and $\Delta\vartheta$ (in addition to β and using the initial mass), and the corresponding Δa , Δe_x , and Δe_y are analytically determined [26]. Tentative values are corrected according to a Newton's scheme to achieve the required orbital changes, given by Eqs. (7)-(9) or (10)-(12). The solution requires the value of the out-of-plane thrust angle, which is kept constant during each burn and progressively adjusted during the iterations to achieve the required plane change, as shown in Section 4. Tentative values for unknown quantities can be easily guessed to start the procedure using averaged effects of thrust components along a complete revolution [22, 26]. After each iteration, the average mass is computed and used with the updated β to evaluate the thrust acceleration for the following iteration.

After convergence, the time duration $\Delta t = \Delta\vartheta/(d\vartheta/dt)$ is computed from $\Delta\vartheta$ assuming the circular angular velocity at the average radius between Earth and asteroid perihelion for the perihelion maneuver, and between Earth and asteroid aphelion for the corresponding burn. The propellant consumption of each burn is then determined as $\Delta t T/c$. The consumption influence at one apsis is neglected when evaluating the average mass for the burns at the opposite apsis.

This evaluation of the transfer is made at different departure points, by varying the initial angle ϑ_0 at 5-degree steps over a complete revolution. The best initial angle for each maneuver is easily selected by a direct comparison of the solutions at 5-degree steps. All the burns are summed up to eventually evaluate the estimation of the optimal overall transfer consumption. The overall propellant mass is therefore $m_p = n(\Delta t_{PA} + \Delta t_{AP})T/c$.

4. Plane Change

Maneuver combination is beneficial; in-plane and out-of-plane thrust components add up as vectors so the thrust effort for a combined maneuver is lower than the sum of the individual efforts. For instance, the vectorial sum of two mutually perpendicular and equal ΔV s is only about 70% of their scalar sum; when a ΔV is much larger than the other one, the vectorial sum almost coincides with the larger ΔV (but the percentage gain over the scalar sum is marginal). As a consequence, the approximation assumes that inclination is adjusted during the apsidal burns necessary for the in-plane problem. A suitable out-of-plane thrust angle, which is assumed to be constant during each burn, is adopted (more properly, β assumes a constant positive value during the half revolution centered at the ascending node and the opposite negative value during the half revolution centered at the descending node). The required overall inclination change is $\Delta i = i_T$, since $i_E \approx 0$. The total change is split between the burns assuming that each maneuver provides an inclination change proportional to the change of the in-plane orbital elements, that is, $\Delta PA = |\Delta a_{PA}| + |\Delta e_{PA}|$ or $\Delta AP = |\Delta a_{AP}| + |\Delta e_{AP}|$ for the two apsides. Actually, an optimal Δi split between the burns exist, but its evaluation would make the estimation procedure complex and increase the computational burden. In order to maintain simplicity and computational speed, the repartition follows here an empirical rule of thumb. Based on the observation that the savings from maneuver combination are larger when the ΔV are similar, good results are expected when a larger Δi is associated to a larger in-plane burn. Numerical verification has shown that the optimal repartition gives only marginal improvements (a few %) with respect to the adopted rule, well within the limits of accuracy expected from the method. One has

$$\Delta i_{PA} = \Delta PA / (\Delta PA + \Delta AP) \Delta i / n \quad (16)$$

$$\Delta i_{AP} = \Delta AP / (\Delta PA + \Delta AP) \Delta i / n \quad (17)$$

From Edelbaum's approximation, the differential equation that expresses the inclination change with respect to the angular position is

$$di = (T/m) \sin \beta \cos \vartheta d\vartheta \quad (18)$$

where $\vartheta = 0$ corresponds to the ascending node. The advantage of thrusting at the nodes, where $di = (T/m) \sin \beta d\vartheta$ is clearly visible. However, a generic burn spans a finite angle $\Delta\vartheta$ and the evaluation of its effect is difficult, even for constant thrust angle. A simple expression for Δi can be obtained for constant- β over 1 revolution ($\Delta\vartheta = 2\pi$, with a sign switch after half revolution), that is, $\Delta i_{2\pi} = 4(T/m) \sin \beta$. The average thrusting effect is therefore

$$\Delta i = \Delta i_{2\pi} / (2\pi) = (2/\pi)(T/m) \sin \beta \Delta\vartheta \quad (19)$$

and was used in Ref. [23] to update the required out-of-plane angle β , given the required inclination change of each burn. The average rate of inclination change

does not account for the position of the burn with respect to the nodes and affects the estimation in many cases. In particular, consumptions are underestimated when the line of apsides is close to the line of nodes, while overestimated when lines of nodes and apsides are in quadrature [23]. The assumption of a constant out-of-plane angle and the position of the apsides with respect to the nodes' location are indeed critical for the estimation accuracy. For this reason, a correction factor K is introduced here to evaluate more consistently the effect of the out-of-plane thrusting, namely by assuming

$$\Delta i = ((2/\pi)(T/m) \sin \beta \Delta \vartheta) / K \quad (20)$$

$$K = k_0 + k_1 k_2 k_3 \quad (21)$$

The terms k_0 , k_1 , k_2 , k_3 are functions of the different orbital parameters or factors that influence the propellant consumption. In particular, three effects are considered: the angle Ω_T between the target line of nodes and apsides, the target eccentricity, and the angular length of the burns. The adopted values are here explained.

The value $k_0 = 0.6$ corresponds to the cost of a plane change precisely at the node. The exact value would be $2/\pi$, which is slightly larger, but the lower value is preferred. The use of an approximate control law usually overestimates the consumption, and the use of a lower value for k_0 partially offsets this fact by reducing the propellant estimation.

The factor $k_1 = 1 - \cos(2\Omega_T)$ penalizes the thrusting effect when apsides and nodes are in quadrature ($\Omega_T = \pi/2, 3\pi/2$), whereas no penalty is added when nodes are close to apsides ($\Omega_T = 0, \pi, 2\pi$).

The factor $k_2 = 1.5e_T$ reduces the penalty for small eccentricities and causes a large penalty for large eccentricity changes. In fact, when the eccentricity is small, the burns to change perihelion and aphelion can be moved away from the lines of apsides and close to the line of nodes with little penalty on the consumption. For instance, if the target eccentricity is zero, the problem concerns the transfer between circular orbits, and the burns to change aphelion and perihelion can be placed at arbitrary angular positions. The burn location close to the line of apsides is instead crucial to minimize cost when the eccentricity is large.

Finally, the factor $k_3 = (3 + \cos \Delta \vartheta) / 4$ accounts for the burn angular length and reduces the penalty for large arcs. In fact, burns that extend for more than 90 degrees always comprise both the line of nodes and the line of apsides. In this case, a variable out-of-plane angle can be adopted in the optimal solution, to increase the out-of-plane thrust component at the nodes, where plane change is more efficiently obtained, thus reducing its cost. The coefficients are selected in order to have K between 0.6 and 1.35 (for a 0.25 target eccentricity). The minimum value corresponds to plane change at the nodes; the maximum value corresponds to plane change performed at about 60 degrees from the line of nodes.

Equation (20) is used in this paper to evaluate the cost of the out-of-plane maneuver and results compared to the estimations without corrections of Ref.

[23]. The approximate solution relies on analytical expressions and is extremely fast; the complete analysis for each asteroid (72 departure points for both periaapsis and apoapsis burns) requires about 1 second on a standard 64-bit Intel i7 3.6 GHz processor. This computational time is comparable to similar analysis with methods based on solutions of Lambert’s problem and impulsive maneuvers (when the number of parameters that describe the trajectory is only few units, three per arc in our case, and a simple algebraic system must be solved). It is at least one order of magnitude lower, in comparison to methods based on direct transcription, even when analytical formulas are used, as the number of variables is much lower.

5. Results

The present work considers the same study-case shown in Ref. [7]; in particular, the focus is here on the 75 NEAs that presented the smallest propellant consumption. A 20-kg spacecraft with solar EP system (3100 s specific impulse 1.74 mN thrust at 1 AU), starting its mission between 2020 and 2023 (included), travels to the selected targets with a maximum 3-year time of flight. Reference solutions are evaluated with an indirect optimization method [27, 28]. The heliocentric transfer from Earth to the asteroid in the two-body problem model is optimized to minimize the propellant consumption. It is worth noting that the dynamical and propulsion system models used here are not exactly the ones used in Ref. [7]. Furthermore, this work considers optimal phasing instead of rendezvous transfer. Consequently, a direct comparison between the results with Ref. [7] is not possible, but they still are significantly consistent.

The estimations presented here concern transfers that insert the spacecraft into the same orbit around the Sun as the asteroid, but do not enforce rendezvous. They represent optimal phasing conditions, in the sense that the solution would correspond to minimal rendezvous consumption if the asteroid were correctly placed [28]. Actual favorable rendezvous opportunities require proper phasing between Earth and asteroid and a procedure to evaluate mission opportunities is also derived. Both the overall angular length and time of flight can be easily estimated: the initial and final positions of each burn are known, so departure and final points are given, depending on the preferred sequence (perihelion or aphelion burn first, both options are readily evaluated). The initial position provides available departure dates, that is, once a year, when the Earth is at the departure point. The time of flight is estimated from the transfer angular length using the average angular velocity between Earth and asteroid. The position of the asteroid at the corresponding arrival date can be compared to the expected arrival position, and favorable rendezvous opportunities happen when the angle between them is sufficiently small. The procedure proves to be effective and also capable of estimating the penalty of rendezvous trajectories with respect to optimal phasing solutions [23]: angular differences below 1 degree have an almost zero penalty, whereas values close to 90 degrees may show a ΔV increase up to 30 %. It is worth noting that the preliminary search of

targets is usually only focused on the best opportunities, i.e., the cases where the difference is small.

In the present section, results from the indirect optimization method are compared to the proposed approximate solutions based on Edelbaum’s approximation from Ref. [23], and to the new results after the introduction of the correction factors presented in Section 4. In most cases, the solutions based on Edelbaum’s approximation present starting points slightly before either perihelion or aphelion, with an almost tangential thrusting (relatively small values of Λ). These solutions remarkably replicate the efficient impulsive scenario used to define the burn sequence.

Among the 75 targets mentioned above, 14 asteroids were excluded because of their large inclination (greater than 5 degrees), large change in semi-major axis (greater than 0.2 AU), or large eccentricity (greater than 0.25). These values seem to be at the applicability limit of Edelbaum’s approximation, which is the basis for this analysis. When transfers with larger variations are sought, lower accuracy is expected. A detailed analysis of the applicability to these transfers has not yet been carried out, but tweaks to the algorithm could be required to allow for the treatment of these cases. Relevant orbital elements and results are shown in Table 1 for the remaining 61 targets. In particular, the reference propellant mass m_p provided by the indirect method can be considered as the “true” optimal solution, and the errors of the estimations with respect to this value in Ref. [23] ($\Delta m_{(R.23)}$) and after the introduction of the correction factor (Δm and its percentage of the propellant mass with the corresponding rank) are presented. The true solutions generally respect the supposed sequence of perihelion and aphelion burns of the approximate analysis, and the results differences can be ascribed to the used simplifications. The purpose of the paper is only the estimation of the propellant mass and does not aim at the estimation of the control law. However, results show a good agreement in terms of arc structure, lengths and (average) thrust angles.

It is evident from the results that the introduction of the correction factor K remarkably improves the estimation, even though in some cases the error is increased. (It is worth noting that these are improvements of the estimations, not improvements of the actual propellant consumption, which is represented by m_p). The average magnitude of the error $\langle |\Delta m| \rangle$ after the correction is reduced to 0.12 kg, a 50 % decrease compared to the value of Ref. [23] $\langle |\Delta m_{(R.23)}| \rangle = 0.18$ kg. The average error is down to 0.09 kg from 0.12 kg (-25 %). The correlation coefficient between reference and estimated propellant mass is 0.96. Despite the average overestimation of the propellant consumption by about 5%, results are still extremely satisfactory, given the approximate method’s simplicity and speed. Note that an “a posteriori” tuning of k_0 could easily solve this issue.

When the correction is not applied, several asteroids showed either underestimation (-0.31 kg in the worst case) or overestimation (up to 0.56 kg) of the propellant consumption. Severe underestimation occurred for asteroids characterized by large values of eccentricity (above 0.15) and apsides-nodes quadrature, such as 2013 RV9, 2012 UW68, 2008 TX3. Asteroids 2014 QH33 and

Table 1: Orbital elements, propellant consumption and estimation errors for the selected asteroid set.

	asteroid	a AU	e	i deg	Ω deg	r_p AU	r_a AU	m_p kg	$\Delta m_{(R,23)}$ kg	Δm kg	rank	$\Delta m\%$	Rank
1	2013 RV9	1.167	0.20	3.511	108.8	0.93	1.40	2.53	-0.31	0.15	40	5.96	31
2	2012 UW68	1.136	0.16	2.472	102.4	0.96	1.31	1.91	-0.25	-0.02	14	-0.92	14
3	2008 TX3	1.179	0.19	2.382	249.9	0.96	1.40	2.14	-0.22	0.16	42	7.37	39
4	2014 QH33	1.085	0.19	2.832	264.4	0.88	1.29	2.50	-0.21	0.02	22	0.66	22
5	2006 QV89	1.192	0.22	1.071	236.7	0.92	1.46	2.23	-0.20	0.25	56	10.98	48
6	2012 UY68	1.175	0.23	2.901	35.8	0.91	1.44	2.47	-0.19	0.16	41	6.34	32
7	2016 TP11	1.037	0.18	1.538	108.2	0.85	1.22	2.17	-0.17	0.00	18	0.06	18
8	2012 HK31	1.074	0.12	2.205	96.7	0.94	1.20	1.82	-0.17	-0.12	3	-6.35	3
9	2015 PL57	1.121	0.14	1.631	115.3	0.96	1.28	1.79	-0.15	-0.02	12	-1.35	12
10	2011 CG2	1.178	0.16	2.757	283.9	0.99	1.36	2.18	-0.15	0.15	38	6.77	34
11	2017 EB3	1.039	0.15	2.84	247.5	0.88	1.20	2.24	-0.13	-0.08	6	-3.50	8
12	2016 UE	1.057	0.15	1.088	296.5	0.90	1.22	1.52	-0.12	-0.01	15	-0.62	15
13	2015 FG36	1.100	0.17	3.514	300.6	0.91	1.29	2.48	-0.12	-0.01	16	-0.32	16
14	2012 UV136	1.007	0.14	2.213	288.6	0.87	1.15	1.74	-0.10	-0.04	9	-2.26	10
15	2014 UY	1.174	0.17	3.565	245.6	0.97	1.38	2.29	-0.09	0.20	47	8.51	43
16	2012 EC	1.152	0.14	0.914	333.9	0.99	1.31	1.57	-0.07	0.06	26	3.73	28
17	2007 UY1	0.951	0.18	1.019	273.6	0.78	1.12	2.04	-0.05	0.14	36	6.59	33
18	2016 TB57	1.102	0.12	0.298	147.8	0.97	1.24	1.06	-0.03	0.03	25	2.93	26
19	2016 CF137	1.090	0.10	2.445	301.5	0.98	1.20	1.43	-0.03	-0.09	5	-6.18	4
20	2009 CV	1.116	0.15	0.943	181.4	0.95	1.28	1.54	-0.02	0.11	32	6.80	35
21	2014 YD	1.072	0.09	1.736	34.1	0.98	1.16	1.11	-0.01	-0.13	2	-11.82	1
22	2017 BF30	1.045	0.13	3.624	256.1	0.91	1.18	2.12	-0.01	-0.03	11	-1.48	11
23	2007 DD	0.987	0.12	2.624	77.6	0.87	1.10	1.70	-0.01	-0.06	7	-3.52	6
24	2013 BS45	0.992	0.08	0.773	150.7	0.91	1.07	1.01	0.00	0.08	30	7.60	40
25	2010 WR7	1.046	0.24	1.563	159.1	0.80	1.29	2.33	0.01	0.20	48	8.36	42
26	2001 QJ142	1.062	0.09	3.104	64.0	0.97	1.15	1.74	0.01	-0.15	1	-8.52	2
27	2016 TB 18	1.078	0.08	1.527	305.6	0.99	1.17	1.02	0.02	-0.04	10	-3.51	7
28	2017 HK1	0.909	0.15	1.51	258.7	0.78	1.04	1.76	0.02	0.06	28	3.64	27
29	2009 HC	1.039	0.13	3.778	269.9	0.91	1.17	2.03	0.03	0.01	20	0.48	19
30	2004 JN1	1.085	0.18	1.5	2.1	0.89	1.28	1.65	0.05	0.13	34	8.05	41
31	2006 FH36	0.955	0.20	1.587	154.7	0.77	1.14	1.97	0.07	0.19	46	9.78	46
32	2004 VJ1	0.944	0.16	1.294	332.3	0.79	1.10	1.77	0.09	0.20	50	11.24	49
33	2003 SM84	1.125	0.08	2.796	87.4	1.03	1.22	1.68	0.10	0.01	19	0.49	20
34	2001 CQ36	0.938	0.18	1.258	344.4	0.77	1.10	1.86	0.10	0.22	51	11.60	52
35	2017 HZ24	0.908	0.22	1.812	312.2	0.71	1.10	2.43	0.11	0.17	43	7.05	37
36	2009 OS5	1.144	0.10	1.695	120.9	1.03	1.26	1.47	0.16	0.14	37	9.42	45
37	2015 BM510	0.947	0.12	1.589	357.3	0.83	1.06	1.45	0.19	0.18	45	12.23	54
38	2010 HA	0.960	0.20	2.183	185.7	0.77	1.15	1.93	0.22	0.22	52	11.45	51
39	2009 RT1	1.156	0.11	4.15	136.5	1.03	1.28	2.15	0.22	0.02	23	0.84	23
40	2014 YN	0.892	0.13	1.208	15.8	0.77	1.01	1.60	0.23	0.20	49	12.39	55
41	2005 TG50	0.923	0.14	2.401	200.9	0.80	1.05	1.68	0.25	0.06	29	3.81	29
42	2000 AE205	1.165	0.14	4.459	150.3	1.00	1.32	2.24	0.25	0.06	27	2.69	25
43	2013 WA44	1.101	0.06	2.302	176.7	1.03	1.17	1.20	0.28	0.03	24	2.20	24
44	2016 FY2	0.869	0.18	1.868	205.0	0.72	1.02	2.14	0.28	0.15	39	7.05	36
45	2006 XP4	0.873	0.22	0.515	346.0	0.69	1.06	2.42	0.31	0.33	62	13.78	57
46	2013 XY20	1.131	0.11	2.863	18.2	1.01	1.25	1.51	0.31	0.11	33	7.07	38
47	2013 HP11	1.185	0.13	4.156	9.5	1.04	1.33	2.21	0.33	0.08	31	3.82	30
48	2017 BF29	1.181	0.13	2.614	203.8	1.02	1.34	1.76	0.34	0.30	60	17.20	61
49	2015 VV	1.137	0.11	4.007	177.2	1.02	1.26	1.87	0.35	-0.02	13	-0.99	13
50	2003 LN6	0.856	0.21	0.66	211.6	0.68	1.04	2.11	0.36	0.31	61	14.58	58
51	2014 SD304	1.168	0.11	2.294	19.3	1.04	1.29	1.59	0.36	0.28	58	17.31	62
52	2013 EM89	1.178	0.12	2.411	189.9	1.04	1.32	1.68	0.37	0.28	59	16.72	60
53	2019 PA7	1.154	0.09	3.472	93.3	1.05	1.26	1.80	0.40	0.25	55	13.58	56
54	1999 AO10	0.912	0.11	2.623	8.0	0.81	1.01	1.54	0.44	0.13	35	8.69	44
55	2001 BB16	0.855	0.17	2.026	195.6	0.71	1.00	2.10	0.45	0.24	54	11.38	50
56	1996 XB27	1.189	0.06	2.465	58.2	1.12	1.26	1.77	0.47	0.27	57	15.04	59
57	2015 TZ24	1.192	0.10	3.35	3.2	1.07	1.31	1.95	0.47	0.23	53	11.77	53
58	2014 MF18	0.886	0.16	2.614	350.4	0.74	1.03	1.76	0.48	0.18	44	10.07	47
59	2007 TF 15	1.109	0.05	4.253	28.9	1.06	1.16	1.77	0.50	-0.09	4	-5.14	5
60	2014 EK24	1.008	0.07	4.805	63.7	0.94	1.08	1.86	0.54	0.01	21	0.64	21
61	2011 AA37	1.096	0.02	3.817	131.5	1.08	1.11	1.53	0.55	-0.05	8	-3.16	9

2006 QV89 are farther from quadrature and closer to apsides-nodes alignment (36 and 45 degrees between them, respectively), but have eccentricity above 0.22. A large value of K penalizes these solutions and increases the propellant consumption; the error becomes positive but, as expected, smaller in absolute magnitude, except for 2006 QV89, which shows a slight increase to about 11% of the propellant mass. The large eccentricity excessively penalizes this case.

In Ref. [23], eighteen asteroids showed errors above +0.3 kg, while ten asteroids presented errors larger than +0.4 kg. Most of these asteroids are close to an apsides-nodes alignment (1999 AO10, 2001 BB16, 2015 TZ24, 2014 MF18, 2007 TF15, 2011 AA37, 2012 WH) and the optimal solution takes advantage of this favorable geometry. This effect is caught by the correction factor K , which becomes small due to k_2 , properly reducing the consumption estimation when thrusting at the nodes becomes possible. Hence, an impressive reduction of the error magnitude is obtained. A similar improvement occurs for small-eccentricity large-inclination asteroids (2019 PA7, 1996 XB27, 2014 EK24) for the combined effect of small values of k_1 and k_3 . The corrected estimations still show some asteroids with negative errors,

but the worst underestimation is now only -0.15 kg and is larger than 0.1 kg in absolute magnitude for only three cases. On the other side, an overestimation above +0.2 kg occurs for only twelve asteroids and above +0.3 kg only for three of them. Asteroids 2003 LN6 and 2006 XP4 have very small periahsis. The real optimal solution performs more than three revolutions in the 3-year time of flight; hence, with four passages at one of the apsides, it can take advantage of shorter and more efficient arcs. If the number of thrust arcs is constrained to 3 at each apsis by reducing the time of flight, the actual consumption is larger and the estimation error decreases to about +0.2 kg for both cases.

As regards asteroid 2017 BF29, the relatively large error has a less clear explanation, but, in general, large errors occur when the periahsis is either small or larger than 1. Figure 2 shows the shape of the asteroids' orbits that present the greatest values of error in the propellant estimation, together with Earth's orbit, assumed to be circular. For ease of comparison and simpler analysis, all orbits are rotated so that the perihelia lie on the positive X axis. Orbits are barely distinguishable, as two groups arise: a family of outer orbits with respect to the Earth, and a family of inner orbits, except for a minimum intersecting arc.

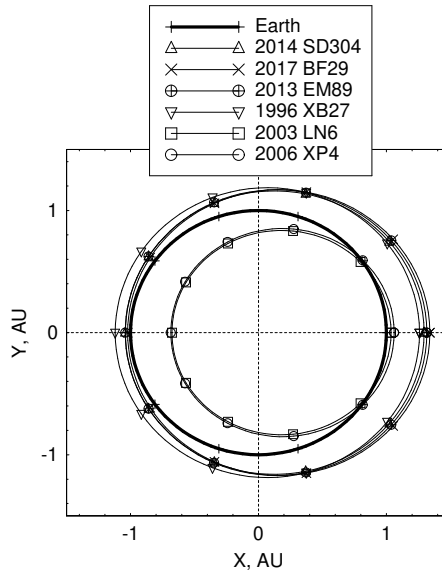

Figure 2: Orbit shape for large-error asteroids.

These groups are both characterized by relatively large values of eccentricity, and Edelbaum’s model starts to suffer from the hypothesis of almost circular orbits.

The thrust angle and the orbit evolution for a transfer to 2001 QJ142 are shown in Figure 3 . The spacecraft performs only two perigee burns at the first two passages to achieve most of the aphelion change (with α close to 0 and with the expected almost linear behavior). The small variation of r_p is reflected in the aphelion burn arcs, which are moved away from the aphelion and shifted towards the node; during these burns, the inclination is changed with large β and small adjustments of perihelion and aphelion (a similar effect will be seen for asteroid 2017 BF 29). In this case, the mission does not follow the strategy of uniform split between apsides burns, but, despite this, the estimation error remains sufficiently small, at about 10%.

Figure 4 presents the thrust angles and the orbit evolution over time for the asteroid 2006 XP4. This transfer has four apogee burns to reduce r_p due to the short revolution period. However, a four-month reduction of the time of flight can prevent the fourth burn, with a propellant consumption $m_p = 2.55$ kg. This value corresponds to an error of only 0.2 kg, or 7.5 % of the propellant mass. In this case, the correction has little effect on the results and actually worsen the error, since Ω_T is close to 360 degrees, and apsis and nodes are close to each other. Shape and inclination are adjusted synergistically and the correction factor, which is close to the minimum value 0.6, has little effect because of the small inclination of the asteroid orbit. The large eccentricity is again the primary source of error.

Figure 5 shows the results for the transfer to asteroid 2017 BF29. In this case, regular perigee burns are used to change the aphelion, even though they are not perfectly centered at the apsis. In similarity to 2001 QJ142, the required perihelion change is small, and aphelion burns are replaced by node burns in order to change the inclination more efficiently. This fact explains the overestimation of the approximate solution, as the real optimal trajectory can take advantage of both node vicinity and large radius and perform an efficient inclination change.

From these examples, which concern the worst estimations provided by the method, it is clear that the basic assumptions to define the burn sequence substantially replicate the real scenario. Alternation of burns at the apsides, linear variation of α in the in-plane control strategy, and effect of eccentricity and line of nodes position on the out-of-plane corrections substantially replicate the real scenario of the optimal solutions, and therefore explain the excellent performance of the estimation method.

6. Conclusions

An analytical method for the evaluation of orbital transfers to NEAs with small eccentricity and inclination has been improved and tested. An analysis of systematic errors of an original formulation has led to the modified method presented in this article. The improvements introduced do not affect the strengths

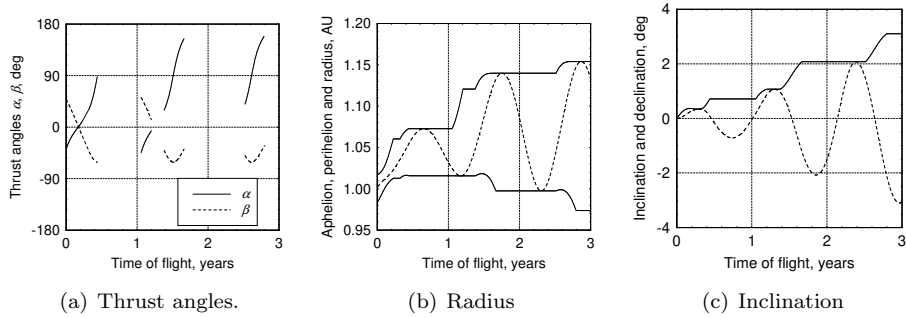

Figure 3: Thrust angles and orbit evolution for optimal transfer to 2001 QJ142.

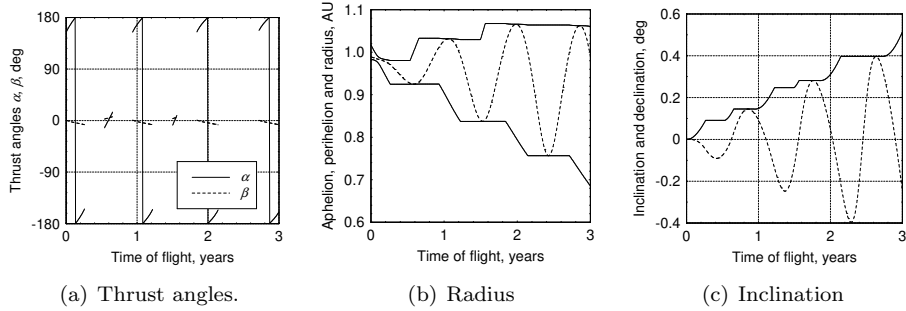

Figure 4: Thrust angles and orbit evolution for optimal transfer to 2006 XP4.

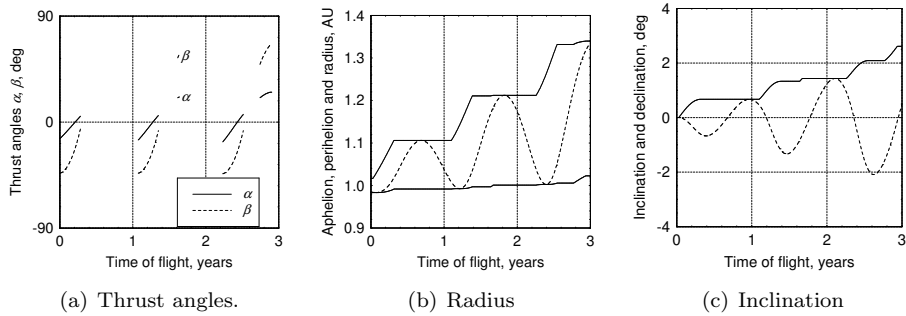

Figure 5: Thrust angles and orbit evolution for optimal transfer to 2017 BF29.

of the method; it does not require the integration of the equations of motion and is sufficiently fast and accurate for the analysis of large sets with hundreds of potential targets in a matter of minutes. Even though examples concerns only trajectories with Earth departure, the method can easily be applied also to NEA-NEA transfers, as far as the eccentricities remain small. For instance, this methodology was employed for the preliminary design of the reference trajectory for the proposed mission NEST – Near-Earth Space Trekker (<https://www.oa->

roma.inaf.it/nest/2018/12/20/ciao-mondo/). The spacecraft was required to rendezvous with 3-4 asteroids in sequence and hundreds of NEA-NEA trajectories had been successfully evaluated to select suitable targets.

Insight on the interaction between the plane-change and planar maneuvers defines a correction factor that significantly improves the estimations. All the targets have errors below 20% (whereas this value was exceeded in 14 cases in the previous version of the method) and for 94% of them (versus 71%) the error is below 15 %. The method supposes optimal-phasing conditions but can be easily modified to consider the actual rendezvous conditions and optimal launch windows, while adding the estimation of the propellant mass necessary for the phasing. In addition, the thrust angles provided by the estimation, can be used as a first guess for a more accurate analysis and transfer optimization.

References

- [1] J. Kawaguchi, A. Fujiwara, T. Uesugi, Hayabusa - Its Technology and Science Accomplishment Summary and Hayabusa-2, *Acta Astronautica*, Vol. 62, No. 10-11, 2008, pp. 639-647, 10.1016/j.actaastro.2008.01.028
- [2] K. Nishiyama, S. Hosoda, R. Tsukizaki, H. Kuninaka, In-Flight Operation of the Hayabusa2 Ion Engine System in the EDVEGA Phase, paper AIAA 2015-3718, AIAA, 2015, 10.2514/6.2015-3718
- [3] C. Russel, C. Raymond, The Dawn Mission to Vesta and Ceres, *Space Science Reviews*, Vol. 163, No. 1/4, 2011, pp. 3-23, 10.1007/s11214-011-98362.
- [4] J. S. Lewis, *Mining the Sky: Untold Riches from the Asteroids, Comets, and Planets*, msur, 1996.
- [5] N. Anthony, M. R. Emami, Asteroid Engineering: the State-of-the-Art of Near-Earth-Asteroids Science and Technology, *Progress in Aerospace Sciences*, Vol. 100, 2018, pp. 1-17, 10.1016/j.paerosci.2018.05.001.
- [6] J. Betts, Survey of Numerical Methods for Trajectory Optimization, *Journal of Guidance Control, and Dynamics*, Vol. 21, No. 2, 1998, pp. 193-204, 10.2514/2.4231.
- [7] A. Mereta, D. Izzo, Target Selection for a Small Low-Thrust Mission to Near-Earth asteroids, *Astrodynamics*, Vol. 2, No. 3, 2018, pp. 249-263, 10.1007/s42064-018-0024-y.
- [8] D. W. Hahn, F. Johnson, Computer Program for Electric Propelled Spacecraft Interplanetary, Flyby, and Rendezvous Trajectory Optimization Based on Chebyshev Approximation and Polynomial Representations, nasa-cr-114354, d180-12916-1, NASA, 1971, 10.2514/6.2014-1721.

- [9] A. E. Petropoulos, J. M. Longuski, The Dawn Mission to Vesta and Ceres, *Journal of Spacecraft and Rockets*, Vol. 41, No. 5, 2004, pp. 787–796, 10.2514/1.13095.
- [10] Wall, B. J., and Conway, B. A., Shape-Based Approach to Low-Thrust Rendezvous Trajectory Design, *Journal of Guidance, Control, and Dynamics*, Vol. 32, No. 1, Jan.–Feb. 2009, pp. 95–101, 10.2514/1.36848.
- [11] De Pascale, P., Vasile, M., and Casotto, S., Optimal Options for Rendezvous and Impact Missions to NEOs, *Journal of the British Interplanetary Society*, Vol. 59, No. 11, 2006, pp. 386–394.
- [12] Vasile, M., De Pascale, P., and Casotto, S., On the Optimality of a Shape-Based Approach Based on Pseudo-Equinoctial Elements, *Acta Astronautica*, Vol. 61, Issues 1–6, 2007, pp. 286–297, 10.1016/j.actaastro.2007.01.017.
- [13] Novak, D.M. and Vasile, M., Improved Shaping Approach to the Preliminary Design of Low-Thrust Trajectories, *Journal of Guidance, Control and Dynamics*, Vol. 34, No. 1, 2007, pp. 128–147, 10.2514/1.50434.
- [14] Greco, C., Di Carlo, M., Walker, L., and Vasile, M., Analysis of NEOs Reachability with Nano-Satellites and Low-Thrust Propulsion, *Proceedings 4S Symposium 2018*, CNES-ESA-DLR-Utah State University, 2018.
- [15] Gondelach, D. J. and Noomen, R., Hodographic-Shaping Method for Low-Thrust Interplanetary Trajectory Design, *Journal of Spacecraft and Rockets*, Vol. 52, No. 3, 2015, pp. 728–738, 10.2514/1.A32991.
- [16] Zuiani, F., Vasile, M., Avanzini, G., and Palmas, A., Direct Transcription of Low-Thrust Trajectories with Finite Trajectory Elements, *Acta Astronautica*, Vol. 72, 2012, pp. 108–120, j.actaastro.2011.09.011.
- [17] Avanzini, G., Palmas, A., and Vellutini, E., Solution of Low-Thrust Lambert Problem with Perturbative Expansions of Equinoctial Elements, *Journal of Guidance, Control and Dynamics*, Vol. 38, No. 9, 2015, pp. 1585–1601, 10.2514/1.G001018
- [18] D. Y. Oh, D. Landau, Simple Semi-Analytic Model for Optimized Interplanetary Low-Thrust Trajectories Using Solar Electric Propulsion, *Journal of Spacecraft and Rockets*, Vol. 50, No. 3, 2013, pp. 609–619, 10.2514/1.A32326.
- [19] D. Y. Oh, D. Landau, Progress on a Simple Analytic Model for Interplanetary Solar Electric Low Thrust Trajectories, paper AIAA 2010-6612, AIAA, 2010, 10.2514/6.2010-6612.
- [20] G. Viavattene, M. Ceriotti, Artificial Neural Network for Preliminary Multiple NEA Rendezvous Mission Using Low Thrust, paper IAC-19C127x51035, IAF, 2019.

- [21] A. Mereta, D. Izzo, A. Witting, Machine Learning of Optimal Low-Thrust Transfers Between Near-Earth Objects, *Lecture Notes in Computer Science*, 2017, pp. 543-553, 10.1007/978-3-319-59650-1_46.
- [22] T. N. Edelbaum, Propulsion Requirements for Controllable Satellites, *ARS Journal*, Vol. 31, No. 8, 1961, pp. 1079–1089, 10.2514/8.5723.
- [23] L. Casalino, L. Mascolo, A. Bosa, Fast Estimation Method for Trajectories to Near-Earth Asteroids, AAS 19-761, 2019, pp. 3089-3100, *Advances in the Astronautical Sciences Series*, Vol. 171, ISBN 978-0-87703-666-1.
- [24] J. McAdams, D. Dunham, L. Mosher, J. Ray, P. Antreasian, C. Helfrich, and J. Miller, Maneuver History for the NEAR Mission - Launch through Eros Orbit Insertion, paper AIAA 2000-4141, AIAA, 2000, 10.2514/6.2000-4141.
- [25] Cornelisse, J.W., Schöyer, H.F.R., and Wakker, K.F., *Rocket Propulsion and Spaceflight Dynamics*, Pitman, London, 1979, pp. 423-424.
- [26] L. Casalino, Approximate Optimization of Low-Thrust Transfers Between Low-Eccentricity Close Orbits, *Journal of Guidance, Control, and Dynamics*, Vol. 37, No. 3, 2014, pp. 1003–1008, 10.2514/1.62046.
- [27] L. Casalino, G. Colasurdo, and D. Pastrone, Optimal Low-Thrust Escape Trajectories Using Gravity Assist, *Journal of Guidance, Control, and Dynamics*, Vol. 22, No. 5, 1999, pp. 637–642, 10.2514/2.4451.
- [28] G. Colasurdo, L. Casalino, Indirect Methods for the Optimization of Spacecraft Trajectories, in: G. Fasano and J.D. Pinter (Eds.), *Modeling and Optimization in Space Engineering*, Springer, E-Publishing Inc., New York, 2013, pp. 141–158, 10.1007/978-1-4614-4469-5_6.