

Analysis of the combustion characteristics of a spark ignition engine equipped with a variable valve actuation system

Original

Analysis of the combustion characteristics of a spark ignition engine equipped with a variable valve actuation system / Luisi, Sabino. - (2014).

Availability:

This version is available at: 11583/2913617 since: 2021-07-19T10:18:03Z

Publisher:

Politecnico di Torino

Published

DOI:

Terms of use:

Altro tipo di accesso

This article is made available under terms and conditions as specified in the corresponding bibliographic description in the repository

Publisher copyright

(Article begins on next page)

ANALYSIS OF THE COMBUSTION CHARACTERISTICS OF A SPARK IGNITION ENGINE EQUIPPED WITH A VARIABLE VALVE ACTUATION SYSTEM

By

Sabino Luisi

Dissertation Submitted to the Doctorate School
of the Politecnico di Torino in Partial Fulfillment of the
Requirements for the Degree of

DOCTOR OF PHILOSOPHY IN ENERGETICS
AT THE POLITECNICO DI TORINO



MAY 2014

Tutor:
Prof. Federico Millo

Scientific Committee:

Prof. Marco BADAMI
Prof. Fabio BOZZA
Prof. Nicolò CAVINA

*Alla mia Famiglia, a mia Madre, mio Padre e mia Sorella,
all'Indomabile Volontà che mi hanno trasmesso*

Ad Angela

ABSTRACT

The present work contains the development of a VVA Multiair turbocharged gasoline engine in which this technology has been used to optimize the engine efficiency on the whole engine map. To this extent the research activity was focused on the pumping loss reduction and knocking mitigation, since they are the main drawbacks in gasoline engine efficiency.

The starting point of the activity was the optimization of the engine turbulence levels in order to maximize the internal EGR tolerance at low engine load, which can allow significant further reductions in terms of pumping losses but, on the other hand, tends to adversely affect combustion stability and to increase cycle-to-cycle variations. Two different modification of the baseline cylinder head configuration have been designed and experimentally tested, with the aim of addressing the issue of the poor in-cylinder turbulence levels, which are typical of the Early-Intake-Valve-Closing (EIVC) strategies adopted in VVA systems. The first layout promotes turbulence by increasing the tumble motion at low valve lifts, while the second one allows the addition of a swirl vortex to the main tumble structure. The aim for both designs was to achieve a proper flame propagation speed at both part and full load. Since the addition of a swirl vortex featured the best trade-off between part and full load performance, it was selected for the further analysis.

The further analysis was focused on the realization of the engine displacement modularity. The aim was to realize a flexible downsizing in order to operate the internal combustion engine in the highest efficiency zone also at low engine loads. At part load the modulation of the engine displacement was obtained with two active and two inactive cylinders. Moreover a new methodology to optimize the inactive cylinder actuation is presented; it consisted in recirculating the EGR not only in the active cylinders but also in the inactive in order to further enhance the engine efficiency without introducing any additional component in the engine layout.

Finally, at high engine loads, the effects of the late intake valve closure (LIVC) on the thermodynamic efficiency have been investigated. The LIVC strategy coupled with a VVA system allows a flexible and cycle by cycle regulation of the effective compression ratio and therefore a sensitive mitigation of knocking occurrence. The activity has been carried out designing and testing a specific intake cam lobe able to perform extreme late closures. Although the high load region is less significant for the CO₂ reduction in the NEDC cycle, it is more representative of the real life engine operation, where calibration actions which are usually required to avoid knock (such as mixture enrichment and spark timing retard) can provoke a dramatic drop in the fuel conversion efficiency. Moreover, knock mitigation could also allow the adoption of a higher geometrical compression ratio at the design stage, with obvious benefits in terms of fuel economy over the entire engine operating map.

In conclusion, the thermodynamic efficiency increased up to 10% at part load and up to 20% in the high load region.

CONTENTS

Abstract	III
1 Introduction	6
1.1 Motivation.....	6
1.2 Gasoline technology review	8
2 Variable Valve Actuation Systems	11
2.1 VVA System technologies..	12
2.1.1 Mechanical VVA.....	12
2.1.2 Electro-Mechanical VVA.....	14
2.1.3 Electro-Hydraulic VVA – Multiair system description.....	16
2.1.4 Electro-Magnetic VVA	24
2.1.5 Hydraulic VVA.....	25
2.1.6 Pneumatic VVA.....	26
3 Induction System Optimization	28
3.1 Experimental setup.....	29
3.2 Part load analysis.....	32
3.2.1 Load sweep at constant speed	33
3.2.2 Speed sweep at constant load	35
3.3 Full load analysis.....	38

4	Engine Displacement Modularity	42
4.1	Experimental setup.....	43
4.2	Deactivation strategy.....	43
4.3	Experimental analysis.....	48
5	Effect of LIVC on Knock Mitigation	55
5.1	LIVC principles	56
5.2	Experimental setup.....	58
5.3	Experimental analysis.....	59
5.3.1	LIVC Test Results summary.....	61
5.3.2	Load sections analysis.....	63
	Conclusions	83
	Bibliography	85

CHAPTER 1

INTRODUCTION

1.1 MOTIVATION

The growing demand for sustainable transportation worldwide has made energy efficiency and the reduction of pollutant emissions a primary selling point for automobiles. The United Nations Intergovernmental Panel on Climate Change (IPCC) concluded that reductions of at least 50% in global CO₂ emissions compared to 2000 levels will need to be achieved by 2025 (see Figure 1.1), to limit the long-term global warming. Although this target is for all sources of CO₂ emissions, the transport sector which is responsible for 23% of energy-related CO₂ emissions [1], contrary to the trends in most other sectors, shows an increase of the total greenhouse gas emissions which are predicted to grow further in the coming years [2] due to the expansion of the global vehicle fleet.

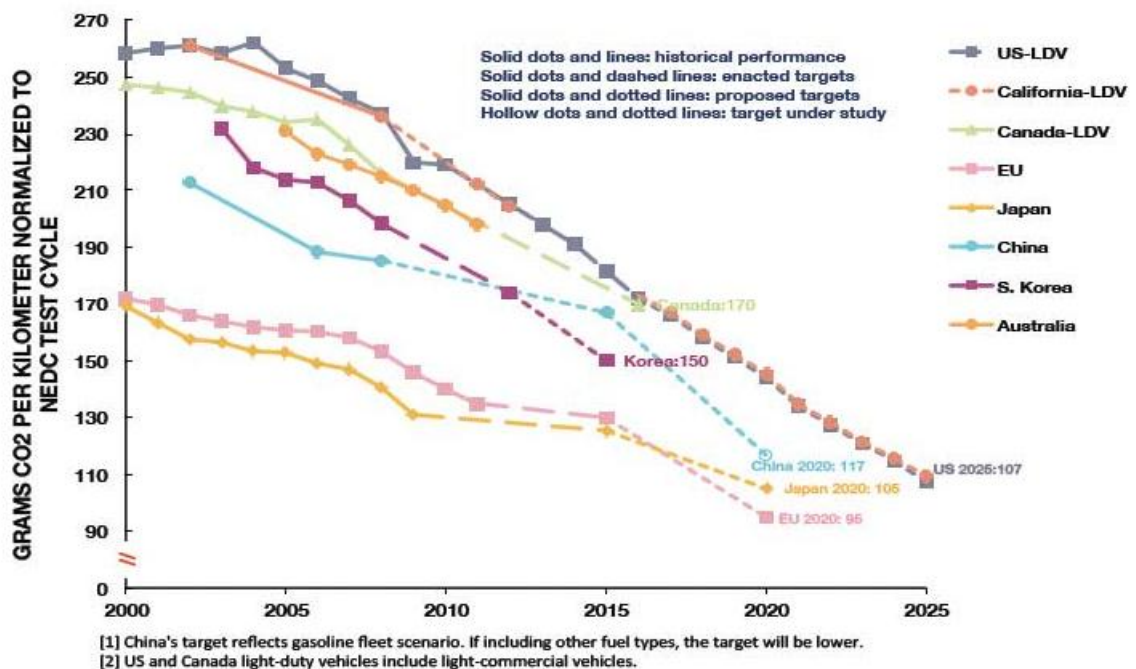

Figure 1.1. Historical fleet CO₂ emissions performance and proposed standards.

As a response to these issues, the European Commission has developed an ambitious and challenging mandatory CO₂ emission reduction program, with a fleet-average CO₂ emission target of 130 g/km to be reached by 2015, and a long-term target of 95 g CO₂/km to be reached from 2020. Indicative targets for post-2020 CO₂ emissions in the range of 68-78 g/km from 2025 were also set in 2013.

The fuel economy standards worldwide also include the US Corporate Average Fuel Economy (CAFE) [3] program and Japan's Top Runner energy efficiency program. China, Taiwan and South Korea have also established mandatory fuel economy standards. The California Air Resources Board (CARB) [4] has issued regulations limiting the fleet average GHG emissions (CO₂, CH₄, N₂O and HFC_s) from passenger cars. The Canadian government also announced it will take measures to reduce GHG emissions, shifting from its earlier voluntary Company Average Fuel Consumption (CAFC) [5] program to mandatory regulatory programs.

Advanced gasoline engines are expected to remain competitive in vehicle applications for the near future. If technologies to improve gasoline engines can obtain a better "cost to benefit" ratio in terms of CO₂ reduction, it will be commercially attractive to introduce them into the new car fleet mix. Moreover, they are more technically mature than hydrogen and electric vehicles and can be deployed using the existing infrastructure. They can offer near-term solutions to address the climate issue, with affordable costs for customers. Market potential may vary between countries depending on availability, prices and the level of fuel duty between petrol, diesel and alternative fuels.

Different technologies are being studied to a greater or lesser interest by different OEMs. Some of these technologies are mutually exclusive while others can be combined with a synergic approach. However in the recent years most of the OEMs introduced in their fleet engines with a high level of downsizing, which allows a shift of load points towards more efficient zones of the engine map, while performance are being preserved or even enhanced despite the smaller displacement thanks to high boost levels. Nevertheless, despite the significant CO₂ reduction on the NEDC cycle, the real life engine operation has been negatively affected by knocking occurrence that implies substantial efficiency loss. To this extent, the aim of the presented investigation involved both the part and the full load engine operation in downsized gasoline engines, equipped with VVA system.

1.2 GASOLINE TECHNOLOGIES REVIEW

Advanced gasoline technologies include a variety of new components and systems aimed at improving the fuel economy and reducing the emissions of greenhouse gases and other pollutants. Major innovations are listed in Table 1. These technologies can act on pumping losses (downsizing with turbocharging, VVA, cylinder deactivation), thermodynamic efficiency (HCCI, stratified combustion, variable compression ratio) and friction losses.

Table 1. Advanced technologies for gasoline engines.

Technology	Status
Downsizing with turbocharging	Production
Variable Valve Actuation (VVA)	Production
Cylinder Deactivation	Production
Variable Compression Ratio	Prototype
Stratified Combustion	Production
Homogeneous Charge Compression Ignition (HCCI)	Prototype
Reduced Engine Friction Losses	Production

Engine Downsizing is seen as one of the most important technologies to reduce fuel consumption and CO₂ emissions through improved engine efficiency, due to the significant load point shift (i.e. the downsized engine is operated at higher load, and therefore with better efficiency, in comparison with a larger displacement engine, if the same torque output has to be reached [6, 7]). It involves a substitution of a naturally-aspirated engine by an engine of smaller swept volume. The downsized engine is typically turbocharged to maintain adequate levels of torque and power output. The amount by which the engines are downsized vary depending on the amount of boost provided by the turbocharger and/or supercharger. Depending on the amount of downsizing, various studies suggest a 2-12% CO₂ reduction.

Variable Valve Actuation (VVA) involves controlling the lift, duration and timing of the intake (or exhaust) valves for air flow. There are two main variants: variable valve timing (VVT) and variable valve lift systems (VVL). The VVT has now become a widely adopted technology. Manufacturers are using many different types of VVT mechanisms (or cam

phaser systems) to control timing of the intake and exhaust valves. The advantages of using VVT include improvement in full-load volumetric efficiency which results in increased torque and reduction in pumping losses during low-load operation, which results in reduced fuel consumption. Depending on the design, VVT may enable 1-4% reduction in CO₂ emissions compared to fixed-valve engines. The VVL system controls the lift height of the valves using two different approaches: discrete VVL and continuous VVL. Compared to VVT, VVL offers a further reduction in pumping losses and low-load fuel consumption. There may also be a small reduction in valve train friction when operating at low valve lift. Most of the fuel economy gain is achieved with VVL on the inlet valves only. This is considered to be a cost effective technology when applied in addition to VVT (cam phase control). A number of manufacturers have implemented VVL (or VVT with VVL) into their fleet. Based on standard (NEDC) driving cycles, BMW found that the VVL system provides fuel savings of up to 10%, and improves cold start behaviour [8,9].

Cylinder Deactivation allows an engine to run on part (usually half) of its cylinders during light-load operation. For example, a 6-cylinder (V6) engine will run on all cylinders during acceleration (or under high load), and switch to four or three cylinders for cruising or low-speed drive. This technology is aimed at large capacity engines (V6, V8 and V12 engines). Pumping losses are significantly reduced when the engine is operated in the “part-cylinder” mode. Several manufacturers have recently incorporated this application into their models. The CO₂ reductions associated to these systems range from 6-8%.

Variable Compression Ratio (VCR) technology enables the compression ratio of an engine to be automatically adjusted to optimise the efficiency of the combustion process under different load and speed conditions. The compression ratio controls the amount by which the fuel/air mixture is compressed in the cylinder before it is ignited. This is one of the most important factors that determines how efficiently the engine can utilize the fuel energy. At low load, a VCR engine operates with high compression ratio in order to maximize fuel efficiency, whilst at high load, low compression ratios are used in order to avoid knock. The potential benefits and the importance of VCR technology have long been known, but this technology is not commercially available yet due to its mechanical complexity. Research done by the European Commission Community showed that VCR engines can achieve a reduction of fuel consumption of up to 9%, compared to state-of-the-art turbocharged gasoline engines with a constant compression ratio of 8.9 [10]. It also suggests that an additional fuel savings of up to 18% can be obtained by downsizing the engine by 40%, while keeping torque and performance constant through high boosting. Thus, this technology, combined with downsizing could enable an overall fuel consumption reduction of up to 27%.

Stratified Charge DI engines involve concentrating fuel spraying close to the spark plug rather than throughout the whole of the combustion chamber. The aim is to produce at part load a stratified mixture (although overall lean), so that throttling can be avoided and pumping and the heat losses significantly reduced. The principle of the stratified charge engine is to deliver a mixture that is sufficiently rich for combustion in the immediate vicinity of the spark plug and a very lean mixture in the remainder of the cylinder, so low in fuel that it could not be used in a traditional engine. On an engine with stratified charge, the delivered

power is no longer controlled by the quantity of admitted air, but by the quantity of fuel injected, as in a diesel engine. These engines operate in at least two modes, depending on load and speed. During low-load and low-speed operation, the engine runs with a stratified charge and with overall lean mixtures. At high-load and high-speed operation, the engine operates as a stoichiometric (or slightly rich) homogeneous charge DI engine. These engines offer higher CO₂ reduction potential than homogenous charge DI engines, ranging from 8-14% compared to PFI and multi-point injection [11, 12, 13, 14]. However, major impediments are cost, complexity and the requirement of expensive lean NO_x traps in the exhaust after-treatment system.

Gasoline Homogeneous Charge Compression (HCCI) - also known as Controlled Auto-ignition (CAI) - is an alternative engine-operating mode that does not rely on the spark events to initiate the combustion. In the HCCI engine, fuel and air are premixed to form a homogeneous mixture; on compression, combustion occurs by self-ignition at multiple sites [15]. HCCI operates in a very lean fuel-air mixture or with a mixture that is considerably diluted with exhaust gases. [16, 17, 18]. A major advantage of HCCI is the exceptional low level of NO_x emissions due to the lower peak-temperature inside the combustion chamber. High CO and unburned hydrocarbons emissions can be the result of incomplete reaction in cool wall boundary layers, but conventional three-way catalysts are efficient enough for removal. Soot emissions are also very low or negligible due to the homogeneous nature of the premixed charge. In terms of fuel economy, this technology can lead to a 10% improvement for a simulated European drive cycle, compared to a homogeneous DI gasoline engine. The major challenges of HCCI are the control of ignition timing and the operation over a wide range of engine speed and loads [18]. Unlike diesel engines where auto-ignition and combustion phasing can be controlled by injection timing, HCCI is controlled primarily by in-cylinder temperature and temperature distribution. This requires variable exhaust gases recirculation (EGR) rates, as well as sophisticated variable-valve actuation and control systems. Because HCCI engines operate in a limited speed/load range, commercial applications are likely to operate in a “dual-mode” between HCCI and Spark Ignition (SI) application. This dual-mode strategy has recently been demonstrated by a car manufacturer. However, HCCI implementation is thought to be about 5-10 years away from high-volume production.

Reduced engine friction technologies include systems, components and materials that minimize the friction between moving metal parts in the engine. These technologies are available in a significant number of engine designs. Several friction reduction opportunities have been identified in piston surfaces and rings, crankshaft design, improved material coatings and roller cam followers. Various studies suggest that the CO₂ reduction potential for engine friction reduction technologies may range from 1-5% [11, 12, 13].

CHAPTER 2

VARIABLE VALVE ACTUATION SYSTEMS

Variable Valve Actuation (VVA) is a generalized term used to describe any mechanism or method that can alter the shape or timing of a valve lift event within an internal combustion engine. In this chapter an overview of the main VVA systems actually available will be presented. There are many ways in which a VVA can be achieved, ranging from mechanical devices to electro-hydraulic and cam-less systems. Variable valve actuation permits to control the air quantity and the swirl and tumble charge motions in the cylinder by changing the valve lift and timing of the intake valves, thus improving charging and combustion efficiencies over the entire range of engine speeds and loads.

2.1 VVA SYSTEM TECHNOLOGIES

The VVA systems are a key technology in gasoline engines for their capability to increase engine efficiency especially at part load. Regarding their architecture, they can be classified as:

- mechanical VVA;
 - electro-mechanical VVA;
 - electro-hydraulic VVA;
- } Equipped with a cam
- electro-magnetic VVA;
 - electro-hydraulic VVA.
 - pneumatic VVA;
- } Cam-less

Despite their full flexibility the cam-less system are not yet in production due to their high cost and to the difficulties in the management of possible failures. On the other hand the electro-mechanical and the electrohydraulic VVAs combine a good valve lift control flexibility with an acceptable cost, and are therefore currently already being adopted by some OEMs, such as BMW and Fiat. In the following sections the above mentioned systems will be analysed on the basis of their working operation principles, of their strengths and finally of their drawbacks. Since all the experimental activity of this dissertation has been carried out on a Multiair engine, a particular focus is given to this electro-hydraulic system.

2.1.1 MECHANICAL VVA

The helical camshaft is a mechanical VVA system, first innovated by Williams and is commonly known as Williams Helical Camshaft (WHC) [1]. It makes use of a mechanical actuation system to offer a wide range of valve opening durations. It importantly differs from other members of this general class by having a unique helical movement – a combined circumferential and axial movement of the two profiles making up the coaxial shaft.

Working Operation:

The mechanism of the WHC consists in a coaxial shaft arrangement where the outer shaft carries the stationary cam lobe. Typically the main lobe body would have duration of about 400 degrees. The stationary lobe (see Figure 2.1) is very long axially, about 45mm, and its profile consists of conventional opening and closing flanks separated by about 170 degrees of constant radius over the nose of the lobe at its maximum duration shape. The lobe has a helical slot machined into it that has a helix angle of about 35 degrees relative to the rotational axis of the camshaft. The width of the slot is equal to the width of the movable lobe, which is

fixed to the inner shaft and moves along this slot axially. A small region along each edge of the movable lobe segment has the same constant radius as the edge of the stationary lobe that it is adjacent to. This means that the movable lobe can be positioned anywhere along the helical slot and there will always be a smooth transition for the follower to and from the segment. The lobe segment is fixed to the inner shaft so that any relative axial movement to the inner shaft has the effect of changing the valve opening duration. The follower is arranged so that it always remains aligned with the segment which remains stationary axially. As the slot has a helix angle of about 35 degrees, any axial movement of the outer shaft causes the segment to rotate, exposing more or less of the nose constant radius and thus changing the duration.



Figure 2.1. A prototype helical camshaft with the camshaft [1]

Drawbacks:

- the control of the axial movement of the inner shaft requires the use of complex centrifugal mechanisms or hydraulic systems which further increase the system cost;
- the use of two segments for the same cam lobe raises issues related to mechanical strength and system reliability.

2.1.2 ELECTRO – MECHANICAL VVA

The Valvetronic system is an example of electro-mechanical variable valve actuation system capable to offer a continuously variable intake valve lift, from ~0 to 10 mm, and duration. The Valvetronic system has been innovated and first implemented by BMW [2]. It has a conventional intake cam, but it also uses a secondary eccentric shaft with a series of levers and roller followers, activated by a stepper motor (see Figure 2.2). Based on signals based on the torque demand coming from the accelerator pedal, the stepper motor changes the phase of the eccentric cam, modifying the action of the intake valves.

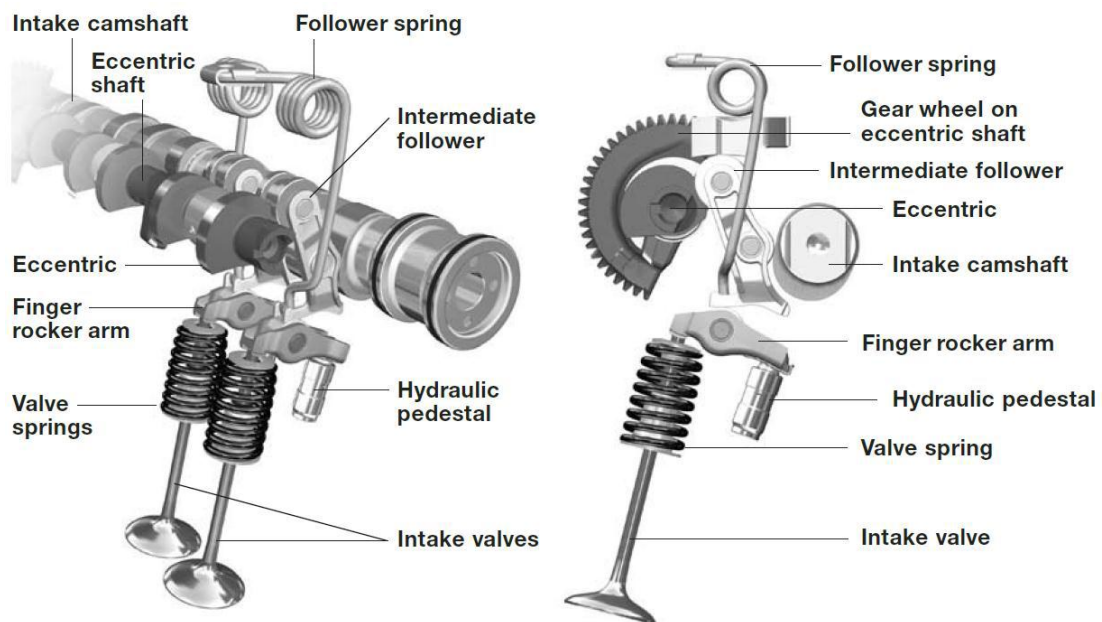

Figure 2.2 Sketch of Valvetronic mechanism [2].

The main components of the system are:

- *Gear wheel on eccentric shaft:*
- *Intermediate follower:* varies valve lift;
- *Rocker arm:* actuates the valve;
- *Hydraulic pedestal:* maintains valve clearance at zero for minimum noise;
- *Intake valve:* opens to admit air and fuel in to the cylinder;
- *Valve spring:* closes valve;
- *Follower spring:* retains and tensions follower.

Working operation:

The intermediate arms pivot on a central point, by means of the eccentric shaft electrically actuated by a stepper motor (see Figure 2.3). The stepper motor is controlled by a control unit that produces signals based on the position of the accelerator pedal. This movement alone, without any movement of the intake camshaft, can vary the intake valves' lift from fully open, or maximum power, to almost closed, or idle. The eccentric shaft in combination with the crank driven cam shaft is capable of producing infinitely varying valve lifts.

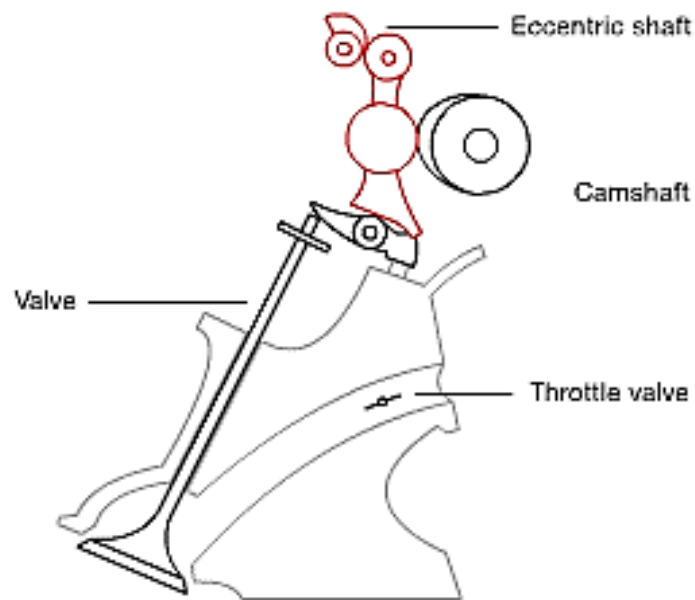

Figure 2.3. Two-Dimensional View of a Valvetronic System for Intake Valves.

2.1.3 ELECTRO-HYDRAULIC VVA MULTIAIR SYSTEM DESCRIPTION

MultiAir is an electro-hydraulic system for dynamic and direct control of air and combustion, cylinder-by-cylinder and stroke-by-stroke. The key parameter to control gasoline engine combustion, and therefore performance, emission and fuel consumption is the quantity and characteristics of fresh air charge in the cylinders. MultiAir is based on direct air charge metering at the cylinder inlet ports by means of an advanced electronic actuation and control of the intake valves, while maintaining a constant upstream pressure.

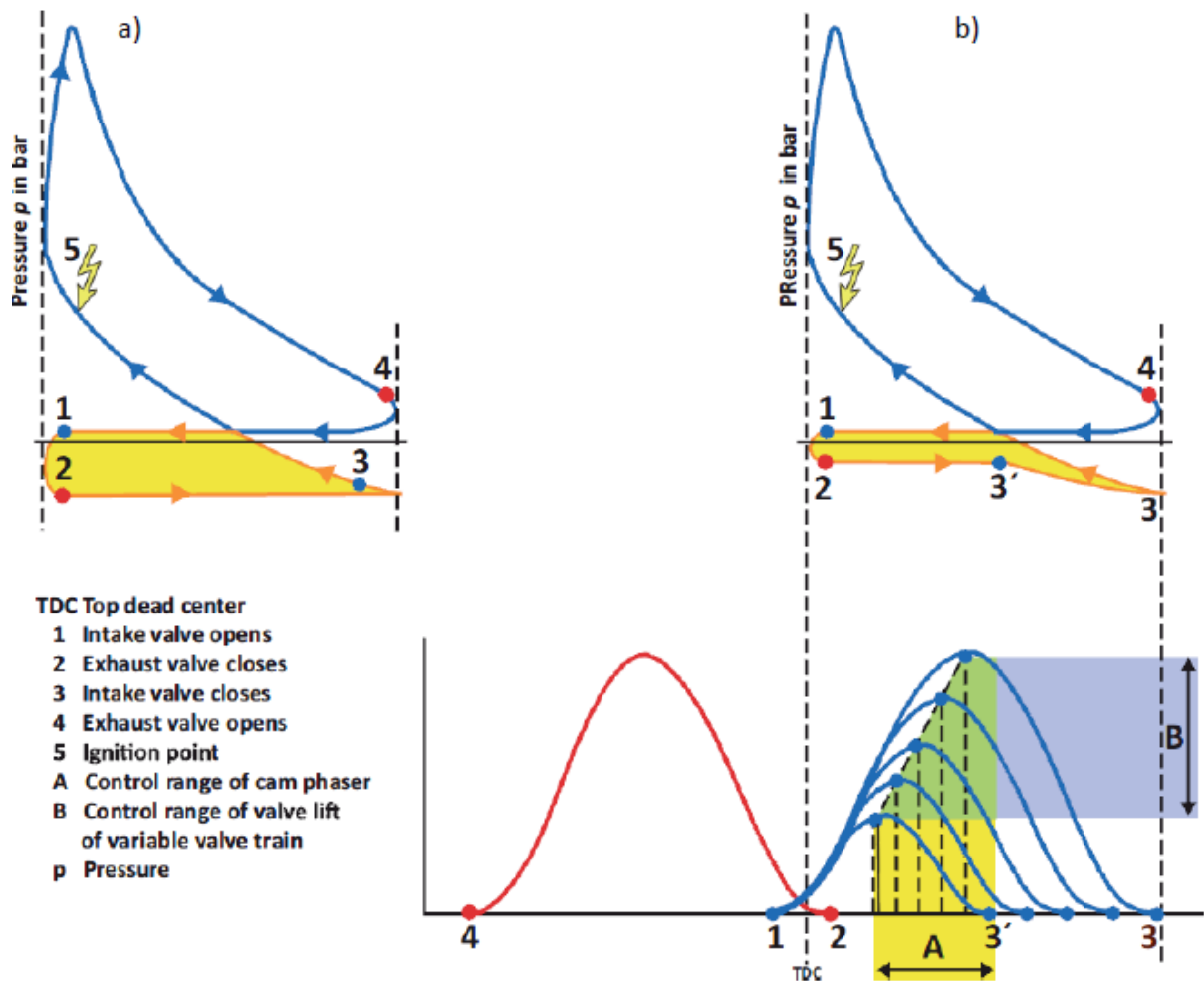

Figure 2.4. Comparison of Pumping works at part load between a) Standard Engine cycle and b) MultiAir engine cycle

This electro-hydraulic valve actuation technology is based on the interposition, between cam and intake engine valve, of an oil volume (high pressure chamber) that can be adjusted through the utilization of an on-off solenoid valve, controlled by a dedicated electronic control unit (see Figure 2.4). The system has been so far applied to the intake

valves of gasoline engines, but it could be extended to also actuate exhaust valves and to Diesel engines.

Different strategies (Early Intake Valve Closing, Late Intake Valve Opening or Multi-Lift) can be used to optimize combustion efficiency, with notable benefits in terms of power, torque, fuel consumption and emissions. Moreover, air pressure upstream the valves, always constant, and the high actuation dynamics of the system (from partial load to full load in one engine cycle) allows for an increasing and prompt engine torque response, both for naturally aspirated and turbo engines, enhancing the so called Fun-To-Drive.

Working Operation:

The system comprises an actuator activated by a camshaft with an integrated fast-acting solenoid valve and valve control software. The operating principle of the system, applied to intake valves, is the following: a piston, moved by a mechanical intake cam lobe, is connected to the intake valve through a hydraulic chamber, which is controlled by a normally open on/off Solenoid Valve (see Figure 2.5).

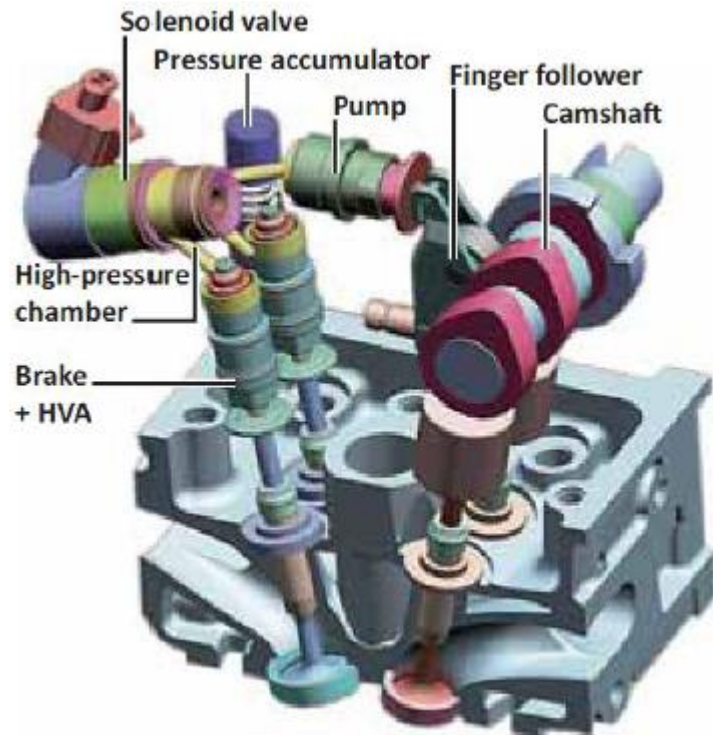

Figure 2.5. MultiAir System – Main Components [3].

When the solenoid valve is open, the hydraulic chamber and the intake valves are decoupled; the intake valves do not follow the intake cam profiles anymore and close under the valve spring action. Shortly before the valve reaches the seat, a hydraulic brake engages to

ensure a soft and regular landing phase in any engine operating condition. Through Solenoid Valve opening and closing time control, a wide range of optimum intake valve opening schedules can be easily obtained. This allows cyclical and individual setting of the valve lift curves for the relevant cylinders and intake valves by controlling the solenoid valves. Hydraulic Valve lash Adjustment (HVA) is also implemented in the system. When the solenoid valve is open, the pressure accumulator feeds the retained oil volume back to the high-pressure chamber to refill the chamber and minimize energy losses. For maximum power, the Solenoid Valve is always closed and full valve opening is achieved following completely the mechanical cam, which was specifically designed to maximize power at high engine speed (long opening time). At part load operation, the Solenoid Valve is opened earlier causing partial valve openings to control the trapped air mass as a function of the required torque. Alternatively the intake valves can be partially opened by closing the Solenoid Valve once the mechanical cam action has already started. In this case, the air stream into the cylinder is faster and results in higher in-cylinder turbulence.

Solenoid description:

The solenoid valves as the control elements for every required lift curve are of central importance for the overall system. System architecture with a “normally open” solenoid valve requires the solenoid valve to switch once per rotation of the camshaft and even several times during multi-lift operation. To ensure that the high-pressure chamber is full and therefore to ensure full lift during the next cycle, the solenoid valve is opened for a short time after each cycle to ensure refilling of the chamber.

In the case of multi-lift operation, it must be ensured that the armature has reached its resting position again after opening for the first time before the solenoid valve is activated a second time. The current for the second lift can only be fed after the armature has been in the resting position for approximately 2 milliseconds. Figure 2.6 shows the activation curve of the current for a solenoid valve and the corresponding engine valve lift curve. The diagram compares early intake valve closing with the full lift curve. A special activation strategy was developed for the solenoid valve current in order to obtain a fast-acting operation with the lowest possible current requirements.

The current profile comprises several sections. The non-activated solenoid valve is first fed with the so called bias current, which pre-magnetizes the solenoid valve but does not switch it. In order to ensure a rapid and precise energizing procedure, increased peak current is applied at the time of switching. The switching point is determined by the software depending on the operating condition. After the solenoid valve has been actuated completely, the current is reduced to holding current which keeps the solenoid valve closed. In turn, the software determines the point in time at which the current is completely switched off, thereby opening the solenoid valve again. The solenoid valve carries out around 330 million switching operations each during the operating life of the system.

It is also necessary to monitor the oil viscosity, particularly during cold starts and the subsequent rise in internal temperature of the system. In this context, and as the only additional sensor for this system, the temperature sensor (see Figure 2.7) is an important component. The sensor measures the oil temperature in real time and supplies an important input for the control unit for determining the oil viscosity. However, the temperature sensor which is normally present on the engine for measuring cooling water and engine oil is not fast enough, and a special sensor with a NTC element (Negative Temperature Coefficient), specifically calibrated for the use at low temperatures (highest precision at 0 °C) has and with a response time of 1.4 seconds has to be adopted. Figure 2.7 also demonstrates the response time as a function of the oil temperature.

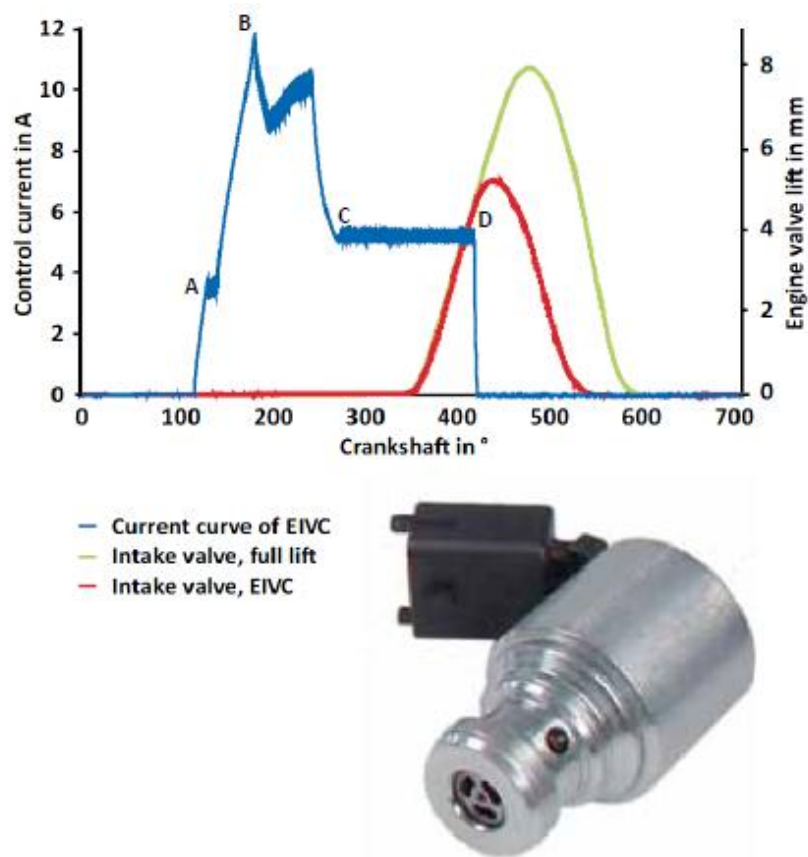

Figure 2.6. Solenoid Valve and Current Curve of the Solenoid Valve

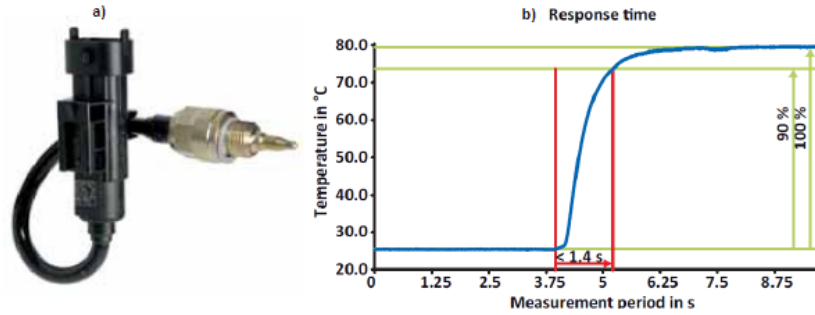

Figure 2.7. a) Temperature Sensor, b) Response time of Temperature Sensor Vs. Oil Temperature

Valve actuation strategies

The MultiAir technology enables an extremely high flexibility in the control of the valve lift, and allows different modes which can assist in meeting the engine's requirements in all operating conditions and consist in:

- full lift mode;
- early intake valve closing mode;
- late intake valve opening mode;
- multi lift mode;
- no lift mode.

The above mentioned modes are described in the following sections with reference to the valve lift profile and to the solenoid actuation required.

Full Lift (FL) Mode

Full valve lift mode is mainly used at maximum engine power. In this mode, the solenoid valve remains closed during the entire cam lift phase and hence the engine is controlled as a standard one, by means of a throttle (see Figure 2.8).

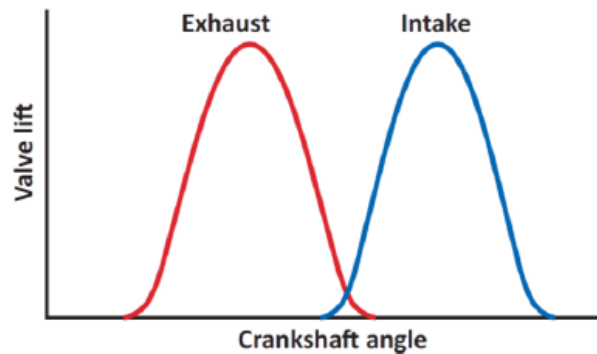

Figure 2.8. Full Lift Mode.

Early Intake Valve Closing (EIVC) Mode

If the solenoid valve is opened before the cam has returned to the base circle, this is called Early Intake Valve Closing (EIVC) mode. Here, the engine valve spring forces the valve towards “closing”. The oil is forced out of the high-pressure chamber to the so-called intermediate pressure chamber that is connected with a pressure accumulator. During early intake valve closing (see Figure 2. 9), the intake valve always performs a ballistic flight phase. This ballistic flight phase is forced by the engine valve spring.

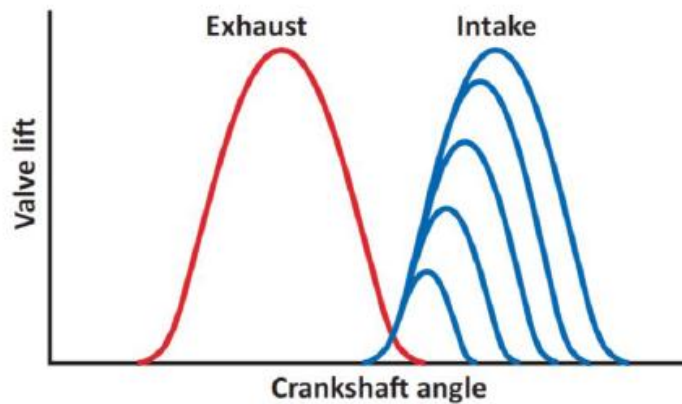

Figure 2.9. Early Intake Valve Closing Mode

The EIVC mode is used in partial load of the engine. During this phase only partial valve lifts are performed and the air volume fed to the cylinder is adjusted in accordance with the torque requirement. Evidently, EIVC is the most promising mode in order to reduce pumping losses.

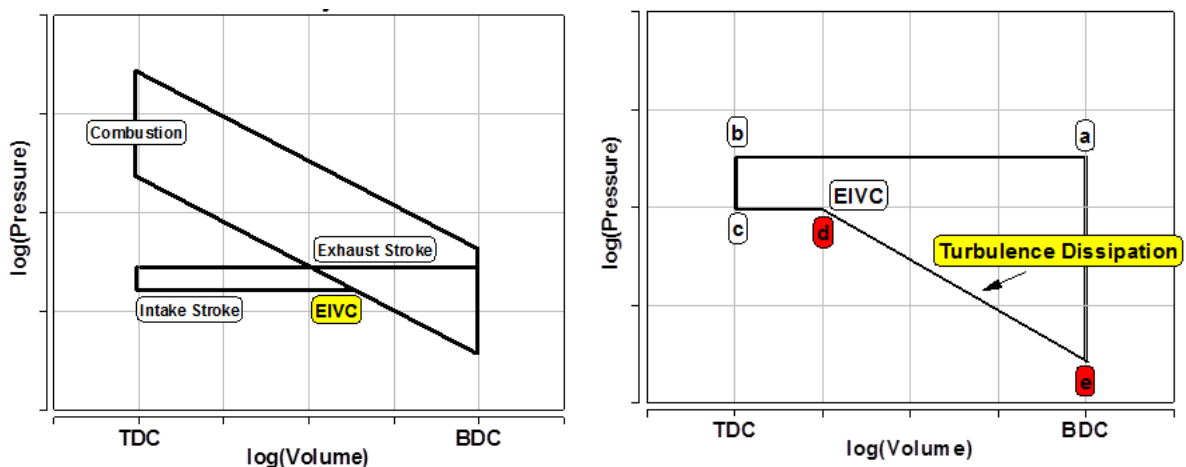

Figure 2.10. Sketch of in cylinder pressure vs. volume for a MultiAir system adopting an EIVC at part load: complete cycle (left), zoom on gas exchange (right); log-log scales.

However, the use of EIVC suffers from poor in-cylinder turbulence especially at low loads; the dissipation of the kinetic energy of the intake air mainly occurs from the EIVC to the BDC, because the intake valves are closed and there is no energy source available to supply the viscosity losses in the trapped air charge (see Figure 2.10). At low loads the EIVC is further advanced towards the TDC, because a lower amount of charge is required, and this results in higher turbulence dissipation if compared with medium-high loads. This is the main **drawback** of the system, that can be mitigated with combustion chamber modifications, designed to increase the turbulence levels in the combustion chamber [4].

Late Intake Valve Opening (LIVO) Mode

To enable late opening of the intake valve (LIVO), the solenoid valve is not fed with current and remains open. The cam forces oil into the pressure accumulator via the pump piston. The solenoid valve is closed in good time before the engine valve opens. This mode and MultiLift operations (engine valve is opened twice in the same cycle) are permitted only at crankshaft speeds of up to 3000 rpm (see Figure 2.11).

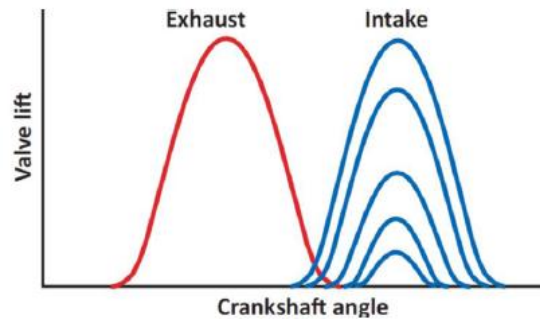

Figure 2.11. Late Intake Valve Opening Mode (LIVO)

Multi Lift (ML) Mode

Multi-lift is a combination of early intake valve closing with another late intake valve opening (see Figure 2.12).

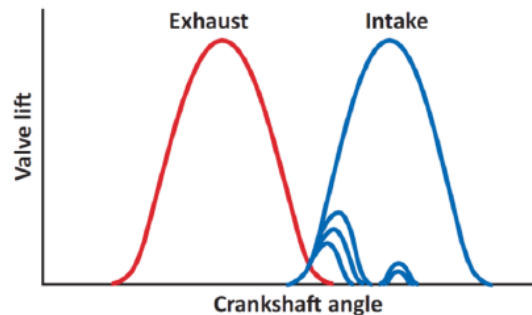

Figure 2.12. Multi Lift Mode (ML)

No Lift Mode

In this mode of Valve actuation, the Intake Valve is kept closed during the entire cam-lift phase.

Since the high flexibility offered by this technology, the MultiAir system offers different **benefits** for gasoline engines can be summarized as follows:

- The pumping loss decrease brings a 10% reduction to Fuel Consumption and CO₂ emissions on NEDC cycle, both in Naturally Aspirated and Turbo Charge engines with the same displacement.
- On NEDC cycle, MultiAir Turbocharged and downsized engines can achieve up to 25% Fuel Economy improvement over conventional Naturally Aspirated engines with the same level of performance.
- Optimum valve control strategies during engine warm-up and internal Exhaust Gas Recirculation, realized by reopening the intake valves during the exhaust stroke, result in emissions emission reduction from 40% for HC / CO to 60% for NO_x .
- Constant upstream air pressure, atmospheric for Naturally Aspirated and higher for Turbocharged engines, together with the extremely fast air mass control, cylinder-by-cylinder stroke, result in a higher dynamic engine response.
- High drivability response to the pedal request, better fun to drive and reduced turbo lag for Turbocharged engines.

2.1.4 ELECTRO – MAGNETIC VVA

Electro-Magnetic VVA (also called e-Valve) is a cam-less variable valve actuation system in which electromagnetic force is used to actuate the valves and facilitates dynamic valve control [3]. The concept of electromagnetically operated valve systems has been studied for years by various companies, but without any great commercial success. The fundamentally specific feature of the e-Valve is that valve control is totally independent on the position of the crankshaft. Moreover, by replacing the throttle valve, the e-Valve system also eliminates pumping losses at part load, which are detrimental for fuel consumption.

Working operation:

Each valve is actuated by two electromagnets that are specifically dedicated to opening and closing the valves (see Figure 2.13). Valve movement is controlled by the two magnets that harness the energy released by two opposing springs. At the start of the valve opening operation, the valve is released by the upper magnet. The upper spring releases, opening the valve. The lower magnet catches the armature plate, fully compressing the lower spring and keeping the valve open for the required time. Valve closure follows the identical procedure in reverse. The valve is kept closed by a locking strategy, reducing the energy being consumed by the magnets. The valves also remain closed while the engine is at standstill. Noise due to the opening and closing of the valves is reduced by controlling the speed of the valve as it reaches the upper and lower limits of its travel.

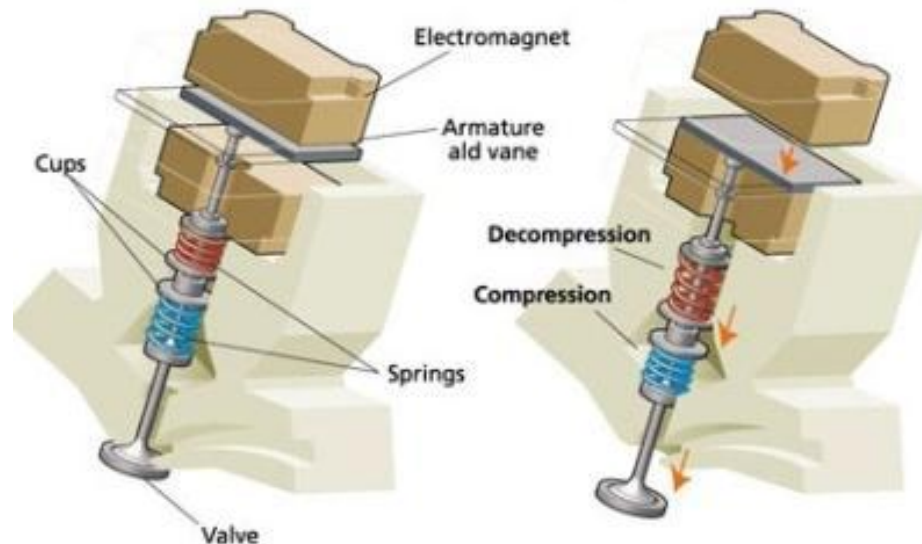

Figure 2.13. Electromagnetic Valve Actuation System [3].

The Valve Control Unit (VCU), which is cooled by the engine cooling system, operates on standard 12-Volt vehicle architecture. It is equipped with a voltage converter to supply current to the actuators with 42 Volts. Current tests on prototype vehicles are focusing largely on half-camless systems, which control inlet valves only and offer most of the benefits and an excellent cost-benefit ratio.

Drawbacks:

- high energy required to operate the valves;
- the springs utilized in this type of system may require very careful balancing with the valve movement in order to achieve a proper gentle valve seating at differing engine speeds.

2.1.5 HYDRAULIC VVA

Hydraulic Valve Actuation (HVA) tries to eliminate the mechanical linkage between the engine valves and the crankshaft and allows for fully flexible engine valve operation [5]. Various methods have been explored to utilize hydraulic mechanisms to move the engine valves. Figure 2.14 demonstrates a HVA system developed by Sturman Industries.

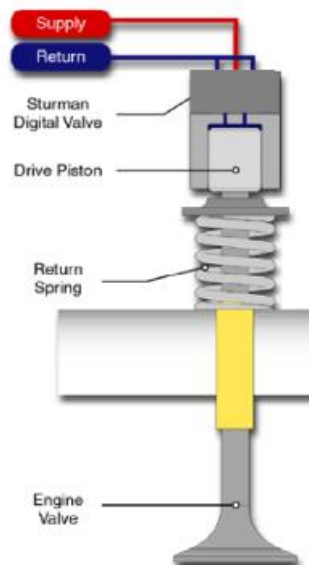

Figure 2.14: Schematic of HVA System developed by Sturman Industries [5]

Drawbacks:

- A fast-acting hydraulic system to activate automotive valves at the speeds required in passenger vehicles could require very high pressures, with all the related issues including the additional energy requirements of the hydraulic pump. Even if higher engine speeds were achieved, valve movement would be reduced and not fully follow the desired or optimum lift schedule.

2.1.6 PNEUMATIC VVA

One way to achieve Variable Valve Control, VVC, is through the use of pressurized air. Pneumatic valve actuation could be easily implemented on heavy duty vehicles since they have an existing system for pressurized air [6]. On passenger cars it would require the addition of a compressor. The system developed and delivered by Cargine Engineering AB consists of an actuator with two solenoids, an actuator piston and logical channels inside the housing, as shown in Figure 2.15.

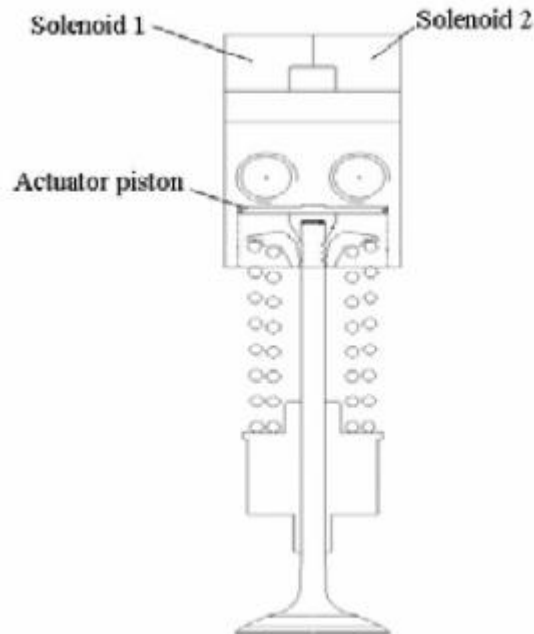

Figure 2.15: Sketch of the Pneumatic Valve Actuator [6]

The left circle in Figure 2.15 is an intake port and is connected the pressurized air. The right circle is the hole for outgoing air, which is released into the atmosphere. When Solenoid 1 is activated pressurized air can enter the actuator, Solenoid 2 stops the filling. Each actuator requires one or two electrical signals, depending on if one or two solenoids are used. This

means that it is possible to operate the actuator with only Solenoid 1 activated and then the lift is only dependent on the pressure supplied. By the use of both solenoids instead of one, it is possible to vary the lift at a given pressure. The actuator is equipped with a hydraulic brake, whose function is to slow down the valve before seating.

Working operation:

- Activation of Solenoid 1 will open the inlet valve to the actuator and thereby determine the starting point of the engine valve opening. The length of the activation time determines the valve opening duration. Another function of Solenoid 1 is that when activated it turns on a hydraulic locking-mechanism that holds the valve at the desired lift where it dwells until the solenoid is deactivated.
- Activation of Solenoid 2 will open the hole for outgoing air. Hence the time difference between the two signals will determine the engine valve lift height. However if Solenoid 2 is chosen to end before Solenoid 1, this will result in another filling, which then leads to an incomplete closure of the valve. To avoid this, it is recommended to choose Solenoid 2 opening to be as long as Solenoid 1.
- Deactivation of Solenoid 1 results in the beginning of valve closure. The hydraulic brake will begin to slow down the valve about 3.0 mm from the end position during valve closing. In the interval 1.0 to 0.0 mm there is a ramp function, which means that the seating velocity is constant in that interval. The magnitude of this constant velocity is approximately 0.5 m/s according to the manufacturers. However this may change with different valve springs due to the pre-compression of the valve spring.

Drawbacks:

- Due to physical limitations in the actuators, stable operation with low valve lifts (below 2.5 mm) is difficult to be obtained.
- High speed operations not feasible.

CHAPTER 3

INDUCTION SYSTEM OPTIMIZATION

In this chapter is presented the evaluation of the combustion behaviour of VVA gasoline engines by analyzing the burn delay and duration with different turbulent pattern in the combustion chamber. The analysis involved the study of the combustion features through the acquisition of the in-cylinder pressure signals.

The experimental investigation was carried out on two different cylinder head modifications of the “baseline” configuration of a MultiAir turbocharged gasoline engine. The first one promotes turbulence by increasing the tumble motion at low valve lifts, while the second one allows the addition of a swirl vortex to the main tumble structure. The target of the designs was the achievement of a proper flame propagation speed at part and full load.

The activity was initially focused on the part load analysis under high dilution of the mixture with internal EGR. The selected engine operating points were representative of the NEDC cycle for a vehicle of the C segment. All the three different configurations (baseline, enhanced tumble, enhanced swirl) were compared in terms of combustion duration and combustion stability for increasing levels of EGR, since the dilution of the mixture can provide significant benefits in terms of reduction of pumping losses, but can on the other hand cause a remarkable deterioration of combustion speed with increased cycle by cycle combustion variability. The second phase of the experimental investigation was then focused on the full load performance in order to catch the effect of turbulence on knocking occurrence.

Finally the cylinder head featuring the best trade-off between full and part load performance was identified.

3.1 EXPERIMENTAL SETUP

The test engine is a Fiat MultiAir Fire 1.4 liter, turbocharged and Port Fuel Injected (PFI), the main features of which are listed in Table 3.1.

Table 3.1 Main specification of test engine.

Displacement	1368 cc
Bore	84 mm
Stroke	72 mm
Compression Ratio	9.8
VVA System	MultiAir, 4 valves/cyl.
Injection System	PFI
Full Rated Power	100 kW @ 5500 rpm
Max Torque	230 Nm @ 2000 rpm

The engine was fully instrumented with piezo-resistive pressure transducers and K-type thermocouples for the measurement of pressure and temperature levels in the following locations: upstream and downstream of the compressor, downstream of the intercooler, in the intake manifold, in the four intake and exhaust runners, upstream and downstream of the turbine. Four KISTLER 6052 C32 piezoelectric transducers were also installed on the engine cylinder head for in cylinder indicating analysis.

Three different system configurations were experimentally investigated:

- a baseline cylinder head (hereafter referred to as “baseline” or “base”), that corresponds to the engine currently under production, and was assumed as a reference;
- a masked cylinder head, that was obtained from the baseline by masking the spark side of intake valves seats in order to enhance tumble motion at low lifts (see Figure 3.1), hereafter this configuration is referred to as “tumble” cylinder head;
- a modified cylinder head which allows a differential intake valves lift actuation, in order to produce an additional swirl motion (hereafter referred to as “swirl” cylinder head). The schematic is reported in Figure 3.2, the differential valve lift is obtained using two different spring stiffness. The lift is differentiated of 8%.

The comparison between the Tumble Ratio of the baseline and of the masked cylinder head configurations is shown in Figure 3.3: Tumble Ratios were measured on flow test rig as a function of the valve lift, and then normalized to the maximum value of the baseline configuration. As can be seen, below 4 mm lifts, the masked cylinder head produces a more intense reverse tumble motion at low lift levels. The amplification of the reverse tumble is

due to the masking location on the spark side of the valve seat: the intake mass flow rate is therefore forced to move to the opposite side (i.e. towards the cylinder liner) and a reverse tumble motion is thus generated. On the other hand at the higher lifts on the contrary the intake flow which is directed towards the exhaust side by the intake ducts design is clearly prevailing, generating an intense direct tumble motion, and the only effect of the masking is then to reduce the tumble intensity, since the masking is hindering the motion of the intake flow towards the exhaust side. The modifications applied to the "masked" cylinder head are therefore expected to enhance the turbulence levels (and therefore the combustion quality) at part loads where EIVC strategies are applied, thus operating the intake valves only at reduce lifts, although the effects of the turbulence worsening at full load, when the full lift profiles are used, will have to be carefully assessed.

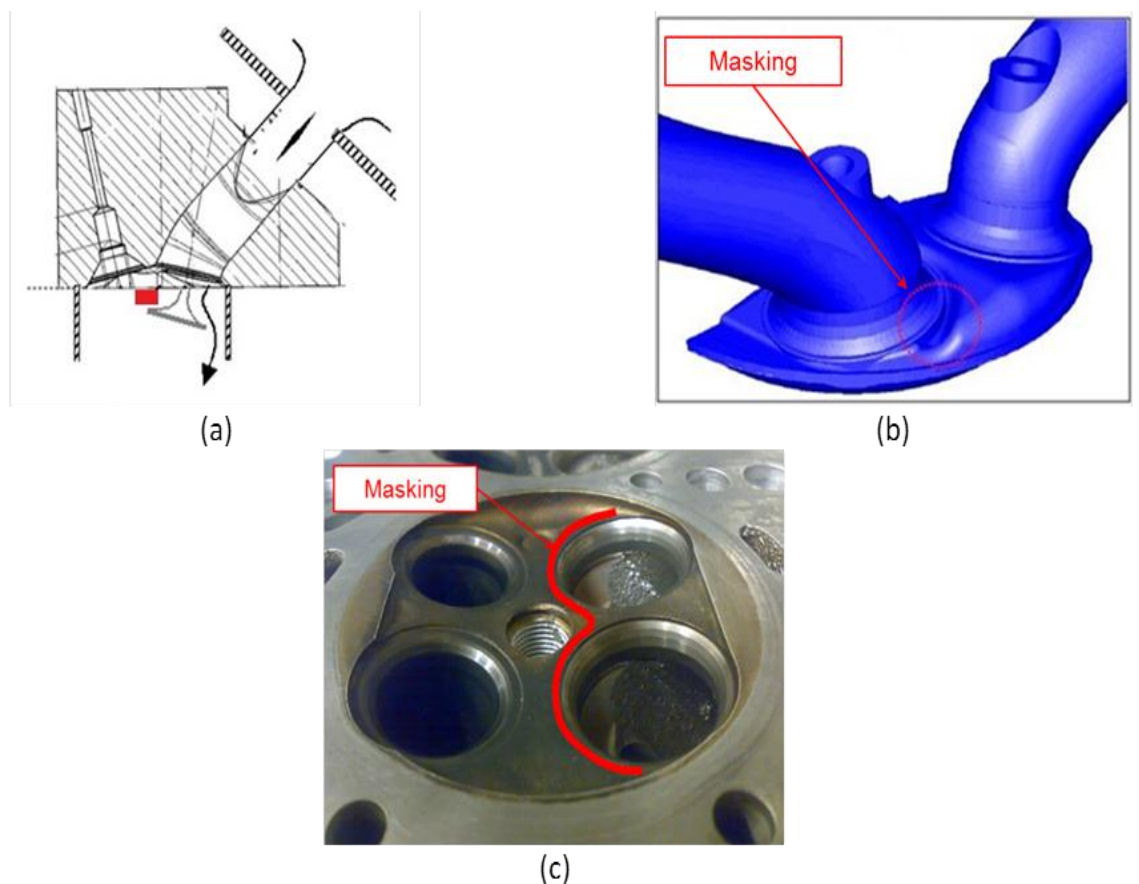

Figure 3.1 (a): Increase of the reverse tumble achieved by the masked cylinder head at low lifts - (b): Sketch of the modifications of the cylinder head - (c): image of the baseline cylinder head with the sketch of the masking.

The comparison between the swirl cylinder head and the baseline is shown in Figure 3.4 in which is reported the swirl number normalized to its maximum value as a function of crank angle. The CFD simulated points are at 2000rpm and 5500rpm, the IVC used is at BDC and the intake manifold pressure is of 1 bar abs. The differential valve lift produces intense swirl during the intake phase, while for the baseline configuration the overall value is almost ten times less than the swirl layout. Also in this case the proposed layout should give better results at part load because of an increased in cylinder motion.

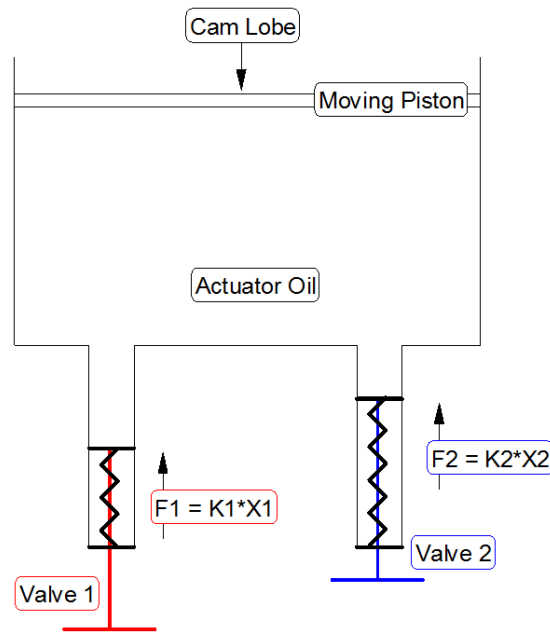

Figure 3.2. Schematic of swirl intake system, the differential valve lift is obtained using different spring stiffness.

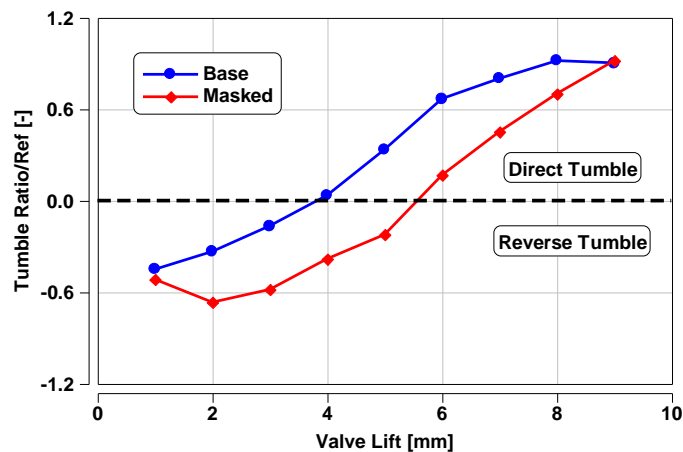

Figure 3.3. Normalized Tumble Ratio as a function of valve lift for baseline and “masked” cylinder head configurations.

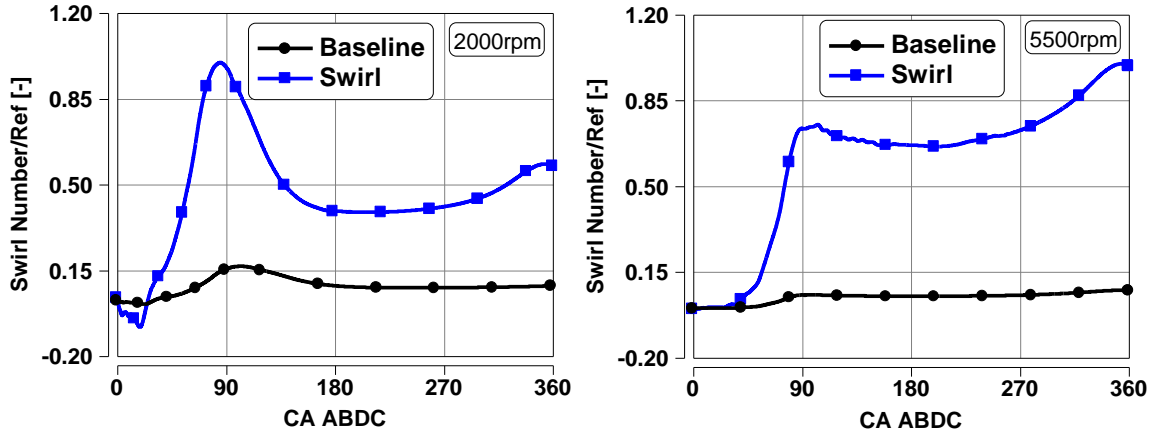

Figure 3.4. Normalized Swirl Number as a function of crank angle for baseline and “swirl” cylinder head configurations. CFD simulated point:2000rpm (left), 5500rpm (right).

3.2 PART LOAD ANALYSIS

At part load the investigation was focused on the comparison of the different cylinder head geometries in terms of combustion duration and EGR tolerance. While the latter was evaluated by means of the Coefficient of Variation of the IMEP (COV IMEP), the effects on the combustion duration were evaluated on the basis of the Mass Fraction Burned (MFB) profiles, by subdividing the combustion process into three main phases: flame development from spark until a 5% fraction of the cylinder mass has burned (0 - MFB5%); first stage of flame propagation (MFB5% - MFB50%) and second stage of combustion (MFB50% - MFB90%). The aim was to individuate which combustion stage is more significantly influenced by the different turbulence patterns produced by the different cylinder head geometries.

Table 3.2. Test points at part load.

ENGINE SPEED [rpm]	BMEP [bar]
1000	4
2000	2
2000	4
2000	7
4000	4

The analysis was carried out at fixed engine load by optimizing the Spark Advance (SA) so as to obtain the best indicated efficiency. The selected operating points are listed in Table 3.2: there is a load section at 2000 rpm (2, 4 and 7 bar BMEP) and a speed section at 4 bar BMEP (1000, 2000 and 4000 rpm) in order to study the effect of the engine speed on combustion stability. For each of these operating points an EGR sweep was performed. From now onwards, for the sake of brevity, each engine operating point will be referred to as “Engine Speed x BMEP”, using rpm and bar units respectively.

3.2.1 LOAD SWEEP AT CONSTANT SPEED

The load sweep investigation begun with the 2000x2, that is the most critical point for EGR tolerance. Due to the low load the IVC has to be anticipated significantly during the intake stroke, thus enhancing the turbulence dissipation effect which is caused by the expansion of the trapped charge. As can be easily seen in Figure 3.5, with the current production layout (baseline) only a few amount of EGR is allowed.

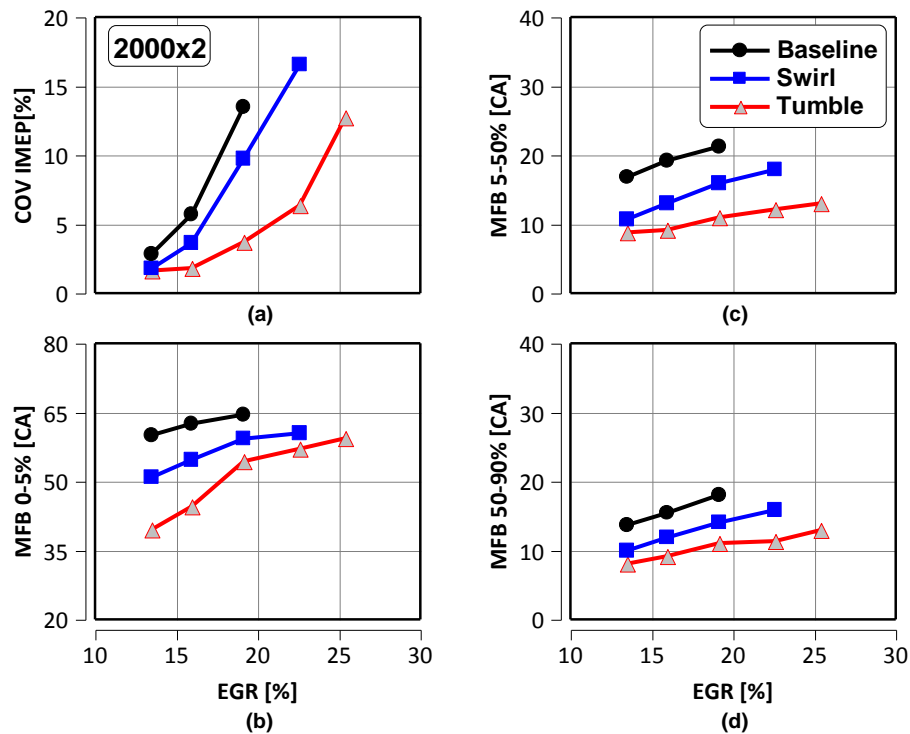

Figure 3.5. EGR effect on COV IMEP (a) and on combustion durations (b-c-d) - 2000rpm x 2bar BMEP.

The masked cylinder head (“Tumble” configuration) shows evident improvements in the combustion process, both in terms of reduced cycle-to-cycle variation and of combustion duration, while the differential valve lift (“Swirl” configuration) is characterized by an intermediate performance between the Tumble and the Baseline layouts. In particular the Tumble configuration allows to recirculate up to 18% of exhaust gases with a COV IMEP lower than 3.5%. The Baseline and Swirl layouts both have an unacceptable deterioration of

the combustion stability as EGR rates are increased above 15%. Looking at the combustion duration trends (see Figures 3.5 b-c-d) the Tumble layout shows positive effects, especially on the flame development angle, (Figure 3.5b) which appears to be the more sensitive to the modifications in the in- cylinder turbulence levels caused by the different cylinder head geometries. The Tumble layout also gives the lowest sensitivity of the first stage of flame propagation (Figure 3.5c) to charge dilution; finally, although the same ranking between the three different layouts is conserved also for the final stage of the flame propagation (Figure 3.5d), their effects on this stage are less pronounced.

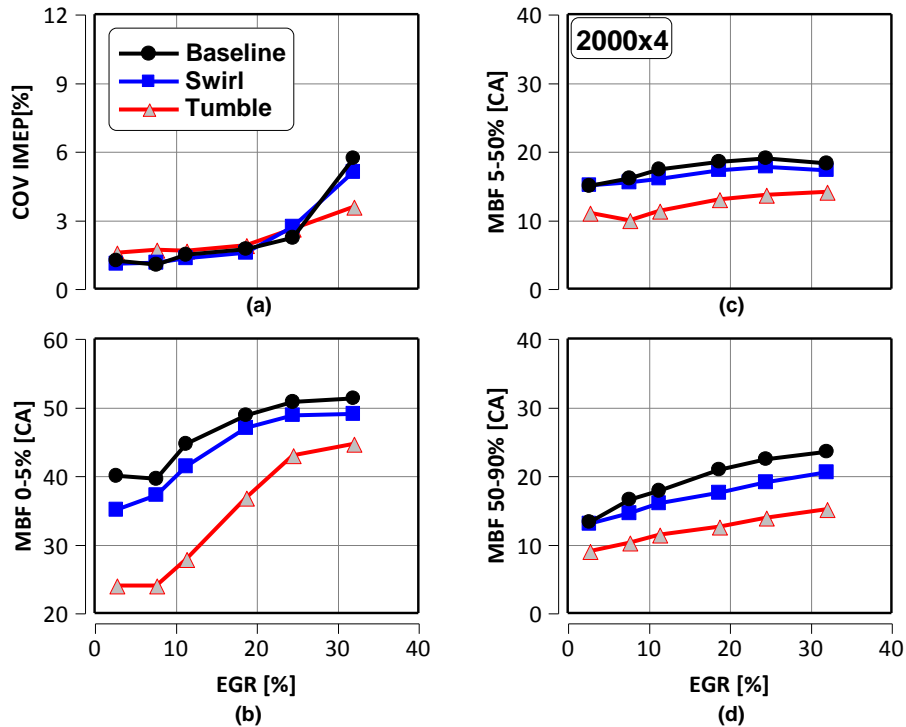

Figure 3.6. EGR effect on COV IMEP (a) and on combustion durations (b-c-d) - 2000rpm x 4bar BMEP.

At 2000x4 (see Figure 3.6) the EGR tolerance is enhanced thanks to the lower turbulence dissipation. There is a good and similar combustion stability for all the three different layouts up to 25% EGR, with COV IMEP values below 3%; nevertheless, only the Tumble solution is capable of achieving still acceptable levels of combustion stability up to 32% EGR. The Tumble is characterized by a faster burning than the other configurations (see Figures 3.6 b-c-d), especially as far as the flame development phase is concerned (Figure 3.6b), the duration of which is almost halved if compared with the baseline solution at low EGR rates. The Swirl solution on the contrary does not provide significant improvements vs. the baseline configuration, probably because, due to the increased load and therefore intake flow, the differential intake valve lift is less effective in generating the swirl motion.

As the engine load continues to increase, at 2000x7 (see Figure 3.7) all the three configurations show a good combustion stability up to 35% EGR (Figure 3.7a), with COV IMEP trends which are almost superimposed. Also the effects of the different layouts on the

combustion duration (Figure 3.7 b, c, d) are less marked, with noticeable improvements achieved by the Tumble layout only as far as the flame development phase is concerned. The increased combustion stability and the shorter combustion duration are due to the more delayed IVC, which is made possible by the increased load, and has more limited detrimental effects on the in-cylinder turbulence levels. The reduced differences between the different layouts can also be attributed to the more delayed IVC, which, by exploiting higher valve lifts, makes the effects of the masking and of the differential lift less important.

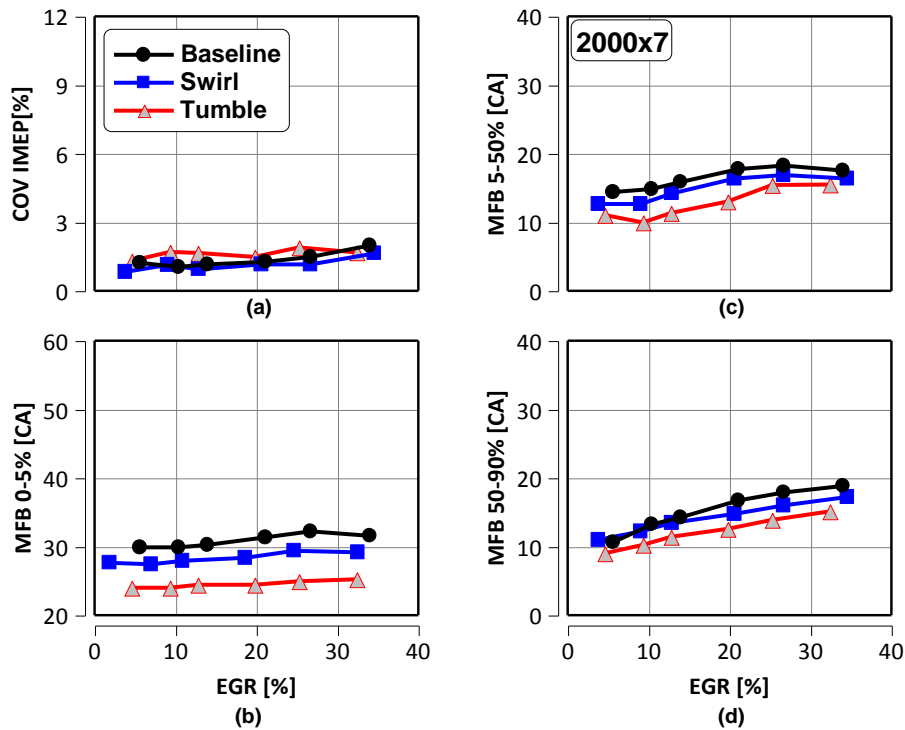

Figure 3.7. EGR effect on COV IMEP (a) and on combustion durations (b-c-d) - 2000rpm x 7bar BMEP.

From the analysis carried out at 2000rpm it can therefore be concluded that the masking has a significant and positive effect in improving the EGR tolerance and in shortening the combustion process, especially at the lowest load, which is the most critical for VVA systems using an EIVC strategy. Moreover, the first phase of the combustion process is more influenced by the masking in comparison with the first and second stages of flame propagation. At the highest load all the three configurations are almost equivalent in terms of combustion stability, with noticeable benefits coming from the masking only as far as the flame development phase duration is concerned.

3.2.2 SPEED SWEEP AT CONSTANT LOAD

The effects of the engine speed can be evaluated by comparing the results obtained at 1000x4 and 4000x4, which are shown in Figures 3.8 and 3.9 respectively, with the results

gathered at 2000x4, shown in Figure 3.6. This intermediate load was selected in order to verify if the combustion stability trends continue to remain similar for the three different induction layouts, as it was found at 2000x4.

At 1000x4 (see Figure 3.8a) the EGR tolerance is decreased to about 20% (it was 25% at 2000x4). This effect can be attributed to the more important deterioration of the turbulence intensity, due to the lower suction speed and to the longer time available for dissipation after the IVC. As far as the combustion duration is concerned, similarly to the 2000x4 results, the flame development phase (Figure 3.8b) is the one which is more sensitive to the induction system layout, with the Tumble solution showing the more significant improvements vs. the Baseline, and the Swirl showing an intermediate behavior between the Baseline and the Tumble layouts.

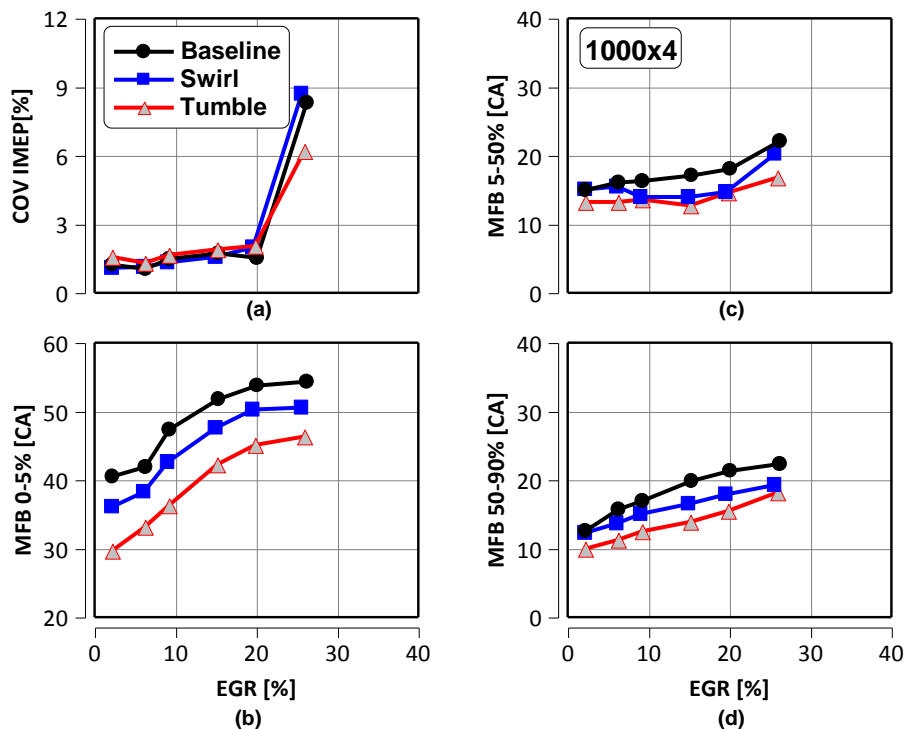

Figure 3.8. EGR effect on COV IMEP (a) and on combustion durations (b-c-d) - 1000rpm x 4bar BMEP.

The results obtained at 4000x4, which are reported in Figure 3.9, show remarkable differences from those gathered at lower speeds. Although all the three different layouts are capable to tolerate up to 30% EGR with acceptable COV IMEP levels (below 3%), a clear ranking is evident, with the Tumble solution showing the lowest cycle to cycle variability (tolerating even 35 % EGR without any noticeable deterioration of combustion stability), and the Baseline showing the highest, with the Swirl configuration almost exactly in the middle. A similar ranking among the different geometries is clearly evident also for the combustion

durations, and especially for the flame development phase (Figure 3.9b), for which the Tumble geometry is capable to achieve a reduction of more than 60% at the lowest EGR rate.

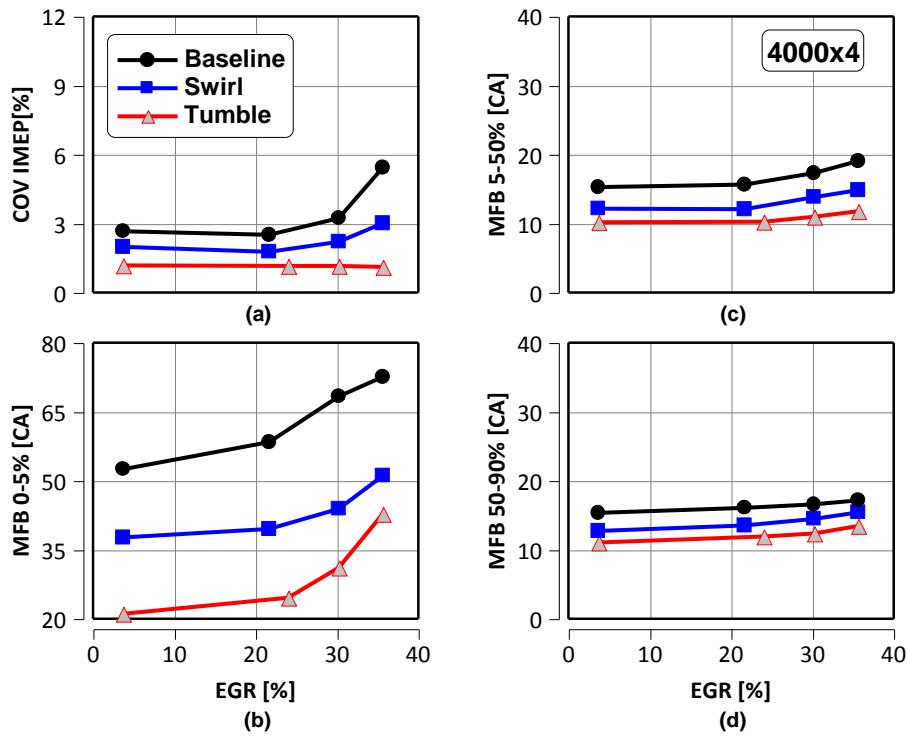

Figure 3.9. EGR effect on COV IMEP (a) and on combustion durations (b-c-d) - 4000rpm x 4bar BMEP.

The reason for this amplification of the effects of the different geometries with increasing engine speed is related to the MultiAir operating characteristics: since the high pressure chamber (see Figure 3.10a) has an emptying time that is almost independent from the engine rotational speed (as shown in Figure 3.10b), in order to trap the same quantity of charge the opening of the solenoid valve needs to be significantly advanced. This results in a prolonged opening of the intake valves at lower lift levels (see again Figure 3.10b), making the masking effects more and more important (see Figure 3.3). Also the use of the differential valve lift provides significant benefits in terms of MFB0-5%, thanks to the additional swirl motion.

From the analysis carried out at constant load (4 bar BMEP) and variable speed, it can therefore be concluded that the Tumble layout has the most significant and positive effect in fastening the combustion process and extending the EGR tolerance, while Swirl layout shows an intermediate performance. In table 3.3 there are the spark advance used in the section at 4 bar BMEP and with an EGR fraction of 20%.

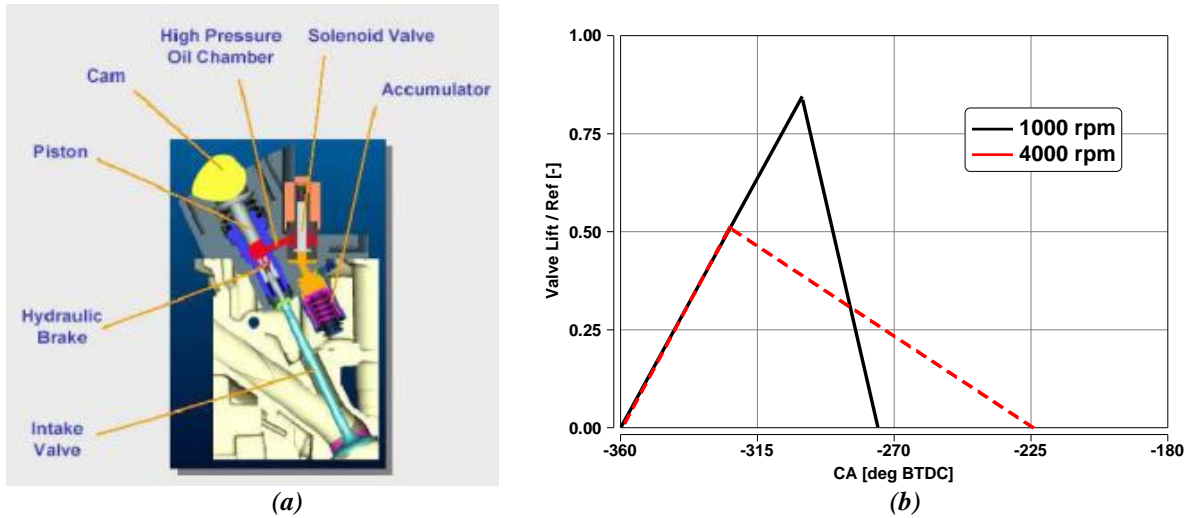

Figure 3.10. Scheme of the MultiAir VVA System (a) and sketch of the effect of the engine speed on the valve lift profile for the same trapped quantity per engine cycle (b).

Table 3.3. Spark Advance at 4 bar BMEP and EGR=20%.

EGR = 20%	Spark Advance [CA BTDC]		
	1000x4	2000x4	4000x4
Tumble	51	41	26
Swirl	56	55	42
Baseline	60	58	60

They are set in order to phase the combustion at the optimal MBF50%, they reflect the effectiveness of the modified layouts (Tumble and Swirl) in speeding combustion as the engine speed increases. This behavior is due to the operating characteristics of the MultiAir system, which lead to more prolonged openings of the intake valves at lower lift levels with increasing engine speed.

3.3 FULL LOAD ANALYSIS

At full load the reduced tumble levels due to the masking (see Figure 3.3, for the high lift range from 6 to 9 mm) are expected to lead to a slower flame propagation, with a decreased combustion rate and therefore a reduced likelihood of knock occurrence. Thanks to this possible knock mitigation effect, the same performance could be reached without the need of spark advance retard, and/or with a decreased fuel enrichment, achieving therefore significant benefits in terms of fuel economy.

The operating points selected for the analysis were 5500 and 2000 rpm in full load conditions, corresponding respectively to the full rated power (103 kW) and to the full rated torque (230 Nm) of the baseline engine (see Table 3.1). The full rated power is generally critical in terms of exhaust temperatures, requiring significant enrichment of the mixture in order to control exhaust temperatures at turbine inlet.

On the other hand, the full rated torque corresponds to the lowest engine speed at which the highest amount of charge per cycle is trapped, and is therefore extremely critical for knock, thus requiring a substantial retard of the spark timing. As a consequence, both operating conditions are usually adversely affected in terms of efficiency by these calibration settings, and therefore a possible knock mitigation could provide significant benefits. The in-cylinder pressure traces and the MFB profiles at 5500 rpm at full rated power conditions (5500 rpm) are reported in Figure 3.11. The three different engine configurations were tested under the same boost pressure and air-fuel ratio conditions, under Knock Limited Spark Advance.

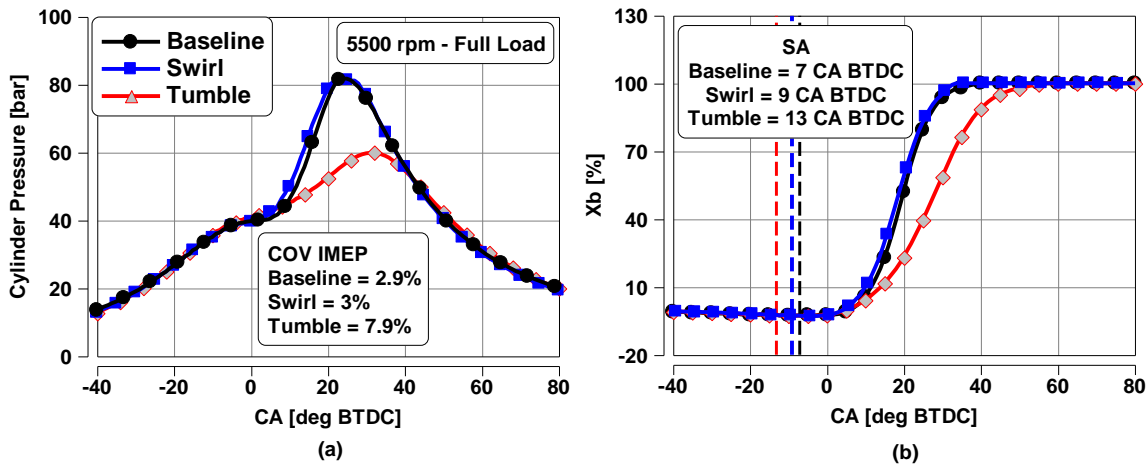

Figure 3.11. In cylinder pressure (a) and MFB profile (b) at full rated power operating conditions (5500 rpm). Spark timing shown with dashed lines.

As expected, the Swirl configuration does not show a remarkably different behavior from the Baseline, since under high load and therefore under high intake flow conditions, the differential intake valve lift is less effective in generating the swirl motion, and does not impact significantly on the combustion characteristics. As a result, both the pressure traces and the MFB profiles are therefore almost superimposed. On the other hand, the Tumble configuration shows a significantly different behavior: as one can immediately notice, the slower flame propagation resulting from the reduced tumble levels leads to significantly delayed combustion development and pressure rise, that the increased spark advance, (13 CA BTDC instead of the 7 CA BTDC of the baseline), made possible by the knock mitigation, is not able to compensate for. The result is a lower peak pressure (60 bar instead of 80 bar), which is reached about 7 CA later than the baseline. The decreased turbulence does not supply a proper mixture formation and the result is a high COV IMEP, over 7% (see

Figures 3.11a and 3.12a). The nonhomogeneous mixture and the combustion stability are thus responsible for knocking occurrence. The spark can not be moved in advance to compensate the slower combustion. The delayed MFB 50% position (28 CA ATDC instead of the 20 CA ATDC of the Baseline) leads to a dramatic worsening of the efficiency, with a power drop of about 10%.

Similar remarks can be made for the rated torque operating point (see Figure 3.12): here again the slower combustion process of the Tumble configuration leads to a significantly delayed MFB 50% position (46 CA ATDC instead of the 30 CA ATDC of the Baseline), which the increased spark advance made possible by the knock mitigation cannot compensate for, resulting in an even more dramatic power loss (about 14% compared with the Baseline). From the full load results it is therefore evident that the Tumble solution cannot reach the performance target, since the knock mitigation is not sufficient to compensate the loss in combustion efficiency. This solution should therefore be discarded, despite the significant benefits provided at part load. On the other hand the differential valve lift does not show significant performance deteriorations, thus fulfilling the full load requirements, although providing only limited benefits at part load.

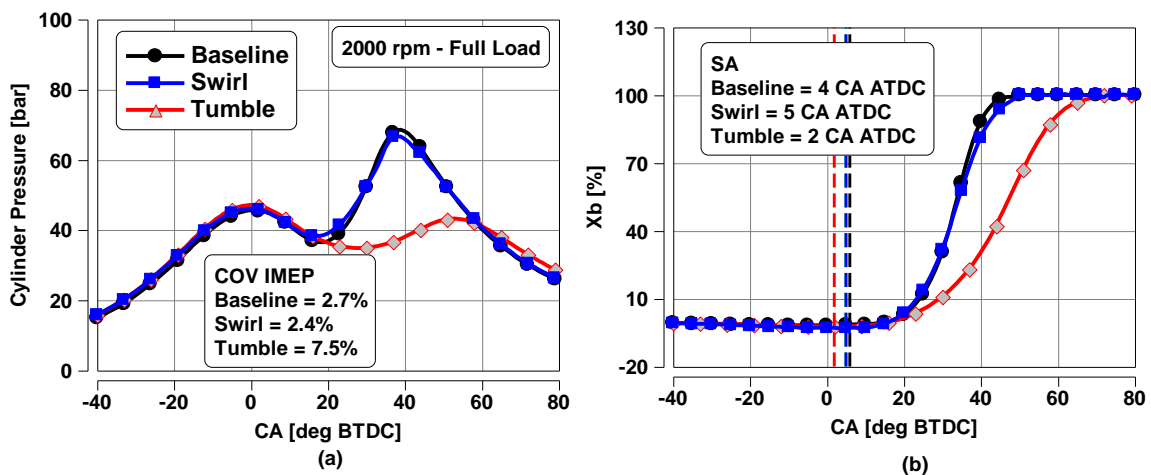

Figure 3.12. In cylinder pressure (a) and MFB profile (b) at rated torque operating conditions (2000 rpm). Spark timing shown with dashed lines.

A possible improvement of the Tumble configuration could be obtained by moving the masking from the spark side to the liner side, thus possibly achieving an appreciable enhancement of the direct tumble motion at low engine loads without excessive tumble deterioration at high valve lifts.

From the analysis carried out at constant speed and variable load, it can be concluded that the enhanced tumble has a significant and positive effect in improving the EGR tolerance and in shortening the combustion process, especially at the lowest load, which is the most critical for VVA systems using an EIVC strategy. Moreover, the first phase of the combustion process (i.e. the flame development) is more influenced by the masking in comparison with

the first and second stages of flame propagation. Finally, at the highest load all the three configurations are almost equivalent in terms of combustion stability, with noticeable benefits coming from the enhanced tumble only as far as the flame development phase duration is concerned.

The second phase of the experimental investigation was then focused on the full load performance in order to assess the effects of the cylinder head modifications on knocking occurrence: the operating points chosen were the full rated power and the full rated torque. The Tumble solution (which enhanced the tumble motion at the low valve lifts used at part load, but decreased the tumble intensity under the full lift operation used at full load) could not reach the performance target, since the knock mitigation was not sufficient to compensate the loss in combustion efficiency due to the slower combustion.

This solution should therefore be discarded, despite the significant benefits provided at part load. On the other hand the Swirl solution did not show significant performance deteriorations, thus fulfilling the full load requirements, although providing only limited benefits at part load.

CHAPTER 4

ENGINE DISPLACEMENT MODULARITY

In this chapter the evaluation of the engine displacement modularity on a VVA gasoline engine is presented. At part load the modulation of the engine displacement was obtained with two active and two inactive cylinders, while additional EGR was used to minimize the global pumping losses of the engine and thus the fuel consumption.

The aim was to realize a flexible downsizing in order to operate the internal combustion engine in the highest efficiency zone also at low engine loads. Moreover, for the active cylinders, the trade-off between pumping losses and combustion stability with highly diluted mixtures was enhanced due the increased turbulence intensity and in-cylinder temperature that are realized by the active cylinders. The experimental analysis involved also the study of the main combustion features through the acquisition of the four in-cylinder pressure signals.

A new methodology to optimize the inactive cylinder actuation is presented; it consisted in recirculating the EGR not only in the active cylinders but also in the inactive in order to further enhance the engine efficiency without introducing any additional component in the engine layout.

The experimental analysis shows that the displacement modularity is effective in the low engine speed/load region. The effect in reducing the pumping loss is significant at the lowest load and decreases as the load increases; the break-even point in terms of load is 3 bar at 2000rpm and 2 bar at 3000rpm. Since the selected engine operating points are representative of the NEDC cycle for a vehicle of the C segment, the displacement modularity represents an effective strategy to further reduce the fuel consumption.

4.1 EXPERIMENTAL SETUP

The test engine is the same used in the analysis of the induction system, presented in the previous chapter, i.e. a Fiat MultiAir Fire 1.4 litre, turbocharged and Port Fuel Injected (PFI). Since in the previous chapter the “swirl” cylinder head showed the best trade-off between the full and the part load performance, it was selected for the next steps in the engine development.

4.2 DEACTIVATION STRATEGY

At part load the investigation was focused on the comparison between the four cylinders mode versus the 2-cylinders mode. Since the combustion regularity must be guaranteed, the couples of cylinders that can be deactivated, with a firing order 1-3-4-2, are the internal (2-3) or the external (1-4) (see Figure 4.1). Although running the engine with three or with one cylinder could also be possible in principle, these solutions have been discarded for obvious NVH reasons.

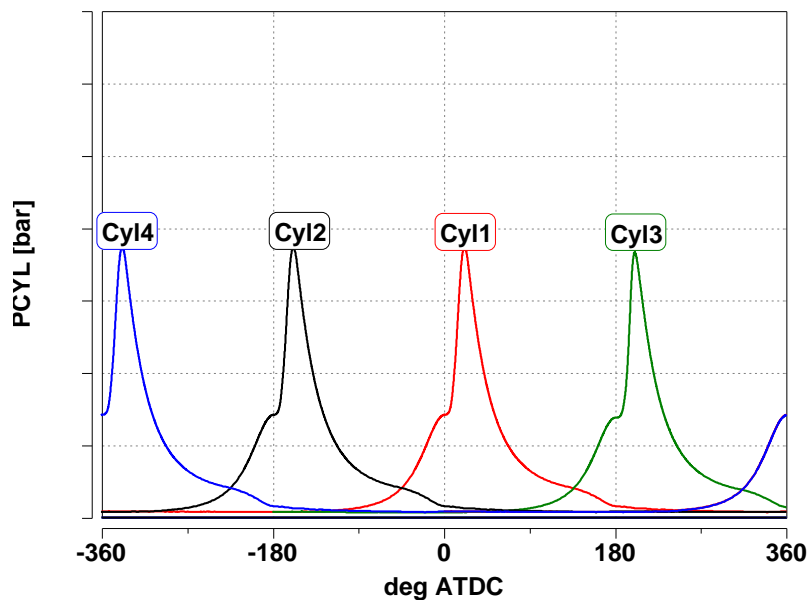

Figure 4.1. In cylinder pressure cycles, firing order: 1-3-4-2.

The aim of the engine displacement modularity is to run the part load operating points with an increased global efficiency. Since in 2-cylinders mode the engine displacement is halved, the active cylinders produce lower pumping losses because they are at a higher BMEP. However the engine displacement modularity is effective until the global engine efficiency is higher than the four cylinder mode; when the load increases too much the active cylinders can be affected by knocking, thus requiring mixture enrichment and/or spark timing retard and no fuel economy can be obtained.

The experimental analysis was carried out at fixed engine load by optimizing the Spark Advance (SA) in order to obtain the best indicated efficiency. The selected operating points are listed in Table 4.1: there is a load section at 2000 rpm (1, 2 and 3 bar BMEP) and a speed section at 2 bar BMEP (1500, 2000 and 3000 rpm) in order to study the effect of the engine speed on the displacement modularity.

Table 4.1. Test points in engine displacement modularity.

ENGINE SPEED [rpm]	BMEP [bar]
1500	2
2000	1
2000	2
2000	3
3000	2

However, it should be pointed out that the cylinder deactivation should be performed by deactivating both the intake and the exhaust valves. Nevertheless, since the MultiAir system allows keeping closed only the intake valves, the activity has been focused on the study of a strategy able to perform the displacement modulation without any additional component on the exhaust valves. In the intake deactivation (see Figure 4.2 left) the exhaust stroke is not superimposed to the intake, compression and expansion strokes because the intake valves are in “no lift” mode. It is easy to note that with this actuation the pumping work is the highest possible.

In order to minimize the pumping loss it is necessary to use a delayed IVC with respect to the intake TDC (see Figure 4.2 right). Although the delayed IVC leads to a pumping loss reduction, the intake of fresh air in the inactive cylinders has to be avoided, because the following exhaust stroke from these cylinders would cause an increase of the oxygen concentration in the exhaust, thus triggering an enrichment of the active cylinders in order to keep the exhaust composition within the TWC lambda window.

Therefore a proper EGR recirculation is required and the IVC has to be set in order to not introduce fresh air in the inactive cylinder. The exhaust gas is clearly produced by the active cylinders; the inactive cylinders are able to recirculate it because at the BDC the in cylinder pressure is lower than the exhaust manifold pressure (see Figure 4.2 right) due to the charge expansion that happens from the IVC to the BDC. The EGR is pushed into the intake runners during the exhaust stroke when the intake valves are open, then it is reintroduced in the inactive cylinders to be compressed, expanded and finally discharged. The iEGR recirculation is obtained by advancing the IVO and thus increasing the overlap between the intake and the exhaust valves (see Figure 4.3). The boot lift profile of the intake profile allows high iEGR recirculation without increasing the maximum valve lift.

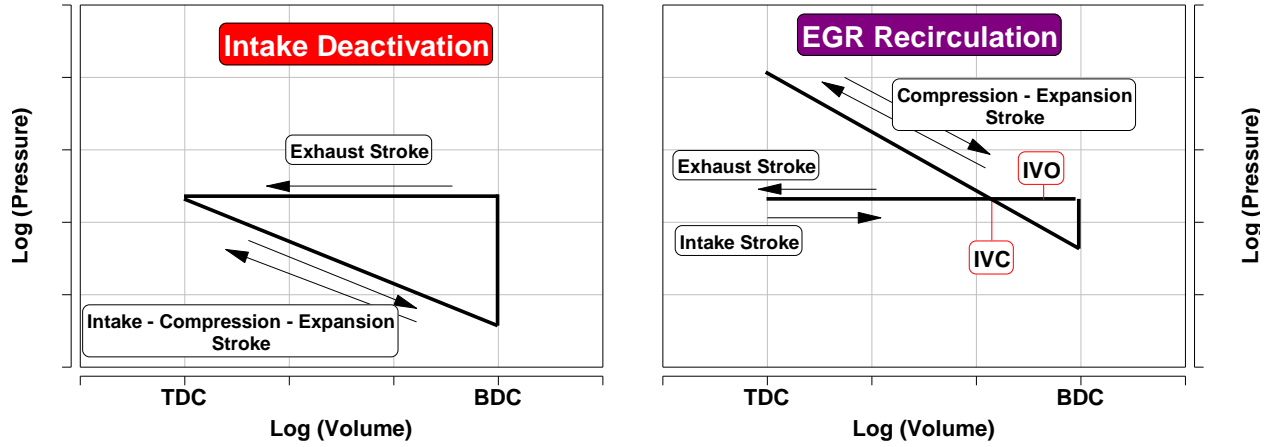

Figure 4.2. Schematic of the pressure cycle for an inactive cylinder with intake valves deactivation, no EGR (left), proper EGR recirculation without introducing fresh air (right).

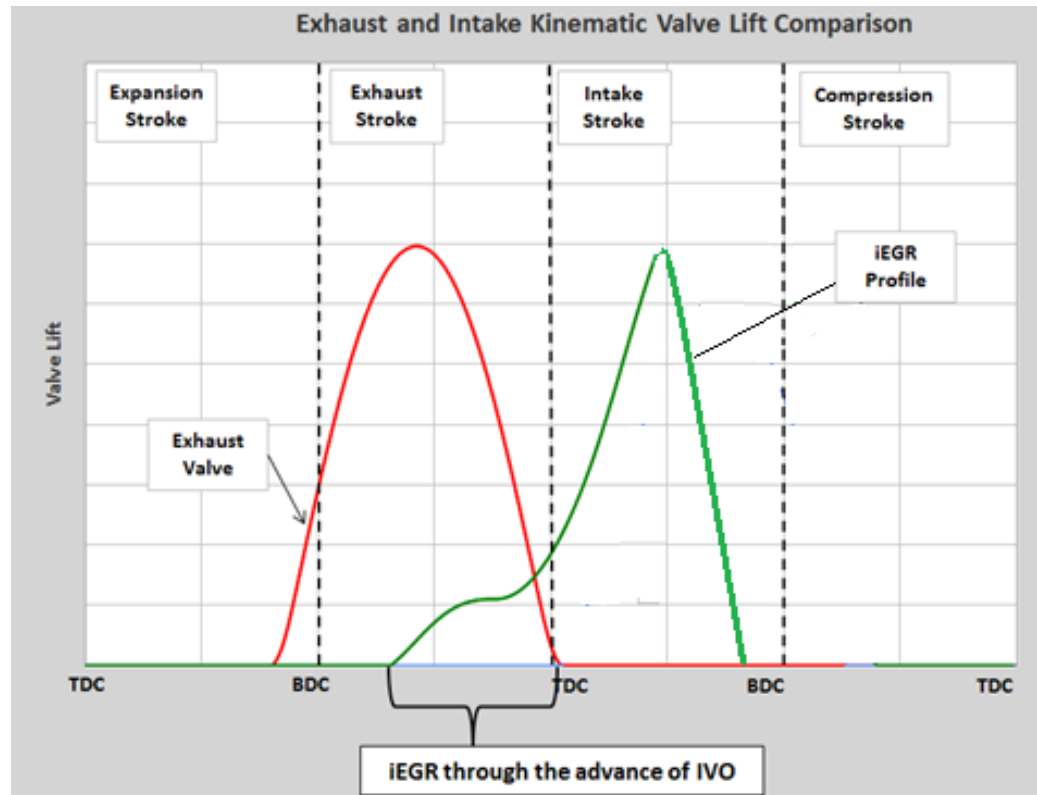

Figure 4.3. Exhaust and intake valve lift comparison: the iEGR actuation could be obtained by advancing the IVO.

Regarding the induction system, the design parameters that limit the maximum amount of internal EGR are: the overlap between the intake and the exhaust valves and the intake runner volume. As a matter of fact even if more EGR can be extracted from the exhaust manifold, only the part that is contained in the intake runner can be reintroduced in the inactive cylinder; the EGR that reaches the intake manifold mixes with fresh air and can not be recirculated in the inactive cylinder only (see Figure 4.4).

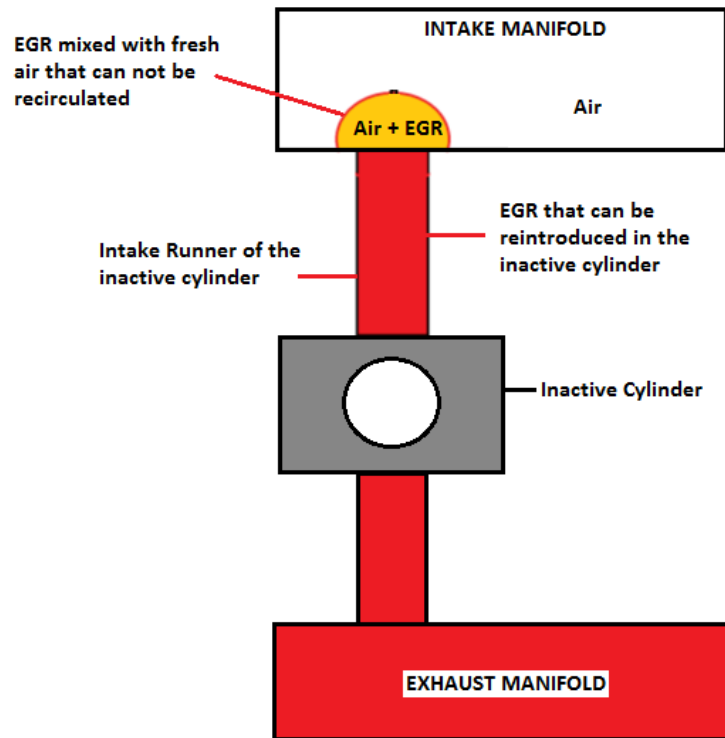

Figure 4.4. Schematic of the EGR recirculation on an inactive cylinder, from the exhaust manifold to the intake runner.

By analysing the total loss of the inactive cylinders there is a trade-off between the pumping loss and the heat loss during the compression of the EGR. Therefore the best compromise between the IMEPL (Indicated Mean Effective Pressure of the Pumping cycle that is calculated during the gas exchange phase) and the IMEPH (Indicated Mean Effective Pressure of the High pressure cycle that is calculated from the beginning of the compression stroke to the end of the expansion stroke) has to be determined through the in-cylinder pressure measurements (see Figure 4.5). From now onwards, for the sake of brevity, each actuation and combustion data will be referred to as “ON” and “OFF”, for the active and inactive cylinders respectively. The IMEPL OFF reaches the maximum value for an IVC of 540 CA ATDC, that corresponds to the maximum volumetric efficiency (see Figure 4.5a), but is quite flat until 480 CA ATDC, while on the other hand the IMEPH OFF decreases because the trapped mass rises (see Figure 4.5c). Globally the IMEP OFF (equal to

IMEPH OFF + IMEPL OFF), reaches its maximum at 475 CA ATDC and is equal to about -0.3 bar.

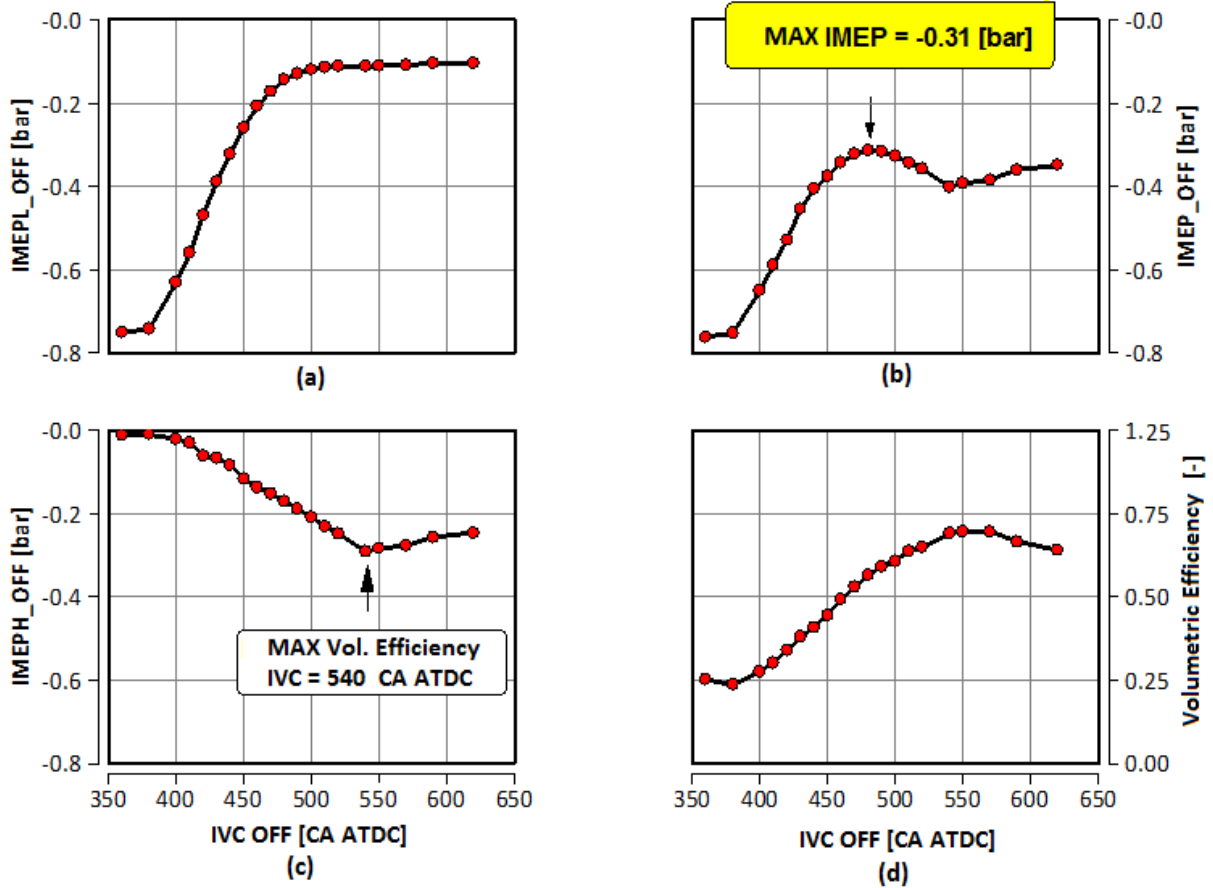

Figure 4.5. IVC sweep of the inactive cylinders: IMEPL_OFF(a), IMEP_OFF(b), IMEPH_OFF (c), Volumetric Efficiency (d).

Although the evidence of this analysis, the intake runner volume could not be optimized for the EGR recirculation due to the high sensitivity to turbo-lag during the transient response and the packaging issues in the vehicle. For the inactive cylinders the calibration of the tested points was therefore limited to finding the proper IVC in order to recirculate the maximum EGR without introducing fresh air, and the O₂ measurement on the exhaust line was used to determine the optimal IVC.

4.3 EXPERIMENTAL ANALYSIS

At part load the investigation was focused on the comparison between the total pumping losses of each operating point listed in the table 4.1. In the load section at 2000 rpm the advantage given by the modularity is highest at 1 bar (see Figure 4.6), while at 3 bar BMEP there is only a slight difference. At 3 bar the 4-cylinder mode is characterized by a similar pumping due to the fact that is possible to recirculate a high amount of EGR that covers the effect of the halved displacement. As a matter of fact, neglecting the effect of heat losses and friction, if the combustion system is able to tolerate all the EGR necessary to bring down the pumping losses, the displacement modularity is not effective in the global efficiency enhancement. At 1500x2 the advantage is similar to the 2000x2, while at 3000x2 the pumping loss is higher than the 4-cylinder mode.

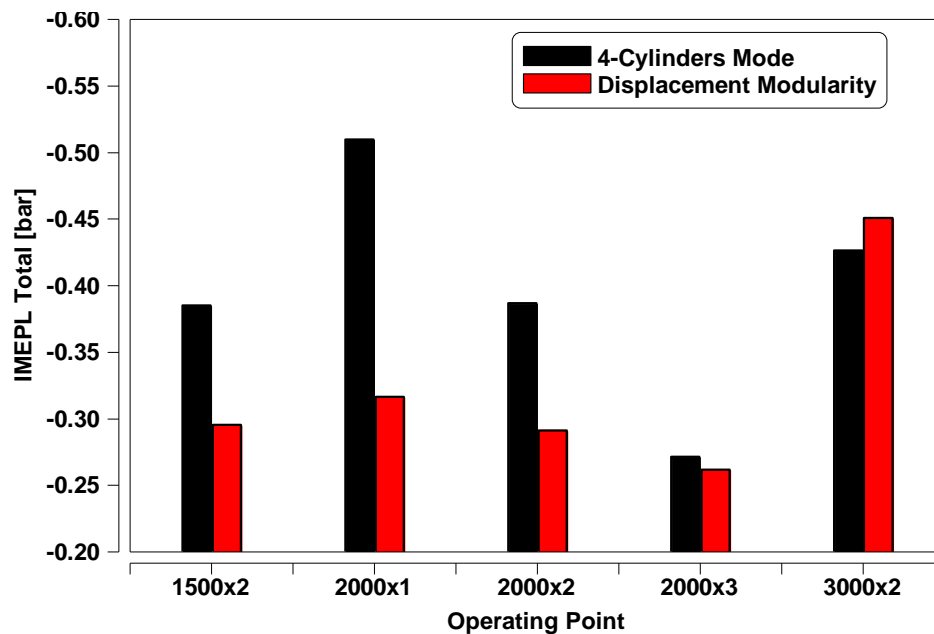

Figure 4.6. Optimized IMEPL Total for the tested operating points.

The optimization of the inactive cylinders has been carried out moving the IVC until O_2 was detected in the exhaust line; it has to be pointed out that also the active cylinders are optimized in terms of EGR, and their load regulation is EIVC since it is the most effective strategy in terms of fuel economy. While the delay of IVC is effective in reducing the IMEPL OFF, the IMEPL ON is almost stable and at a high level because of the increased BMEP and EGR tolerance. These effects are quite evident in Figure 4.7 in which the IVC OFF sweep at 1500x2 is reported (the IVC OFF is expressed as distance from a reference angle).

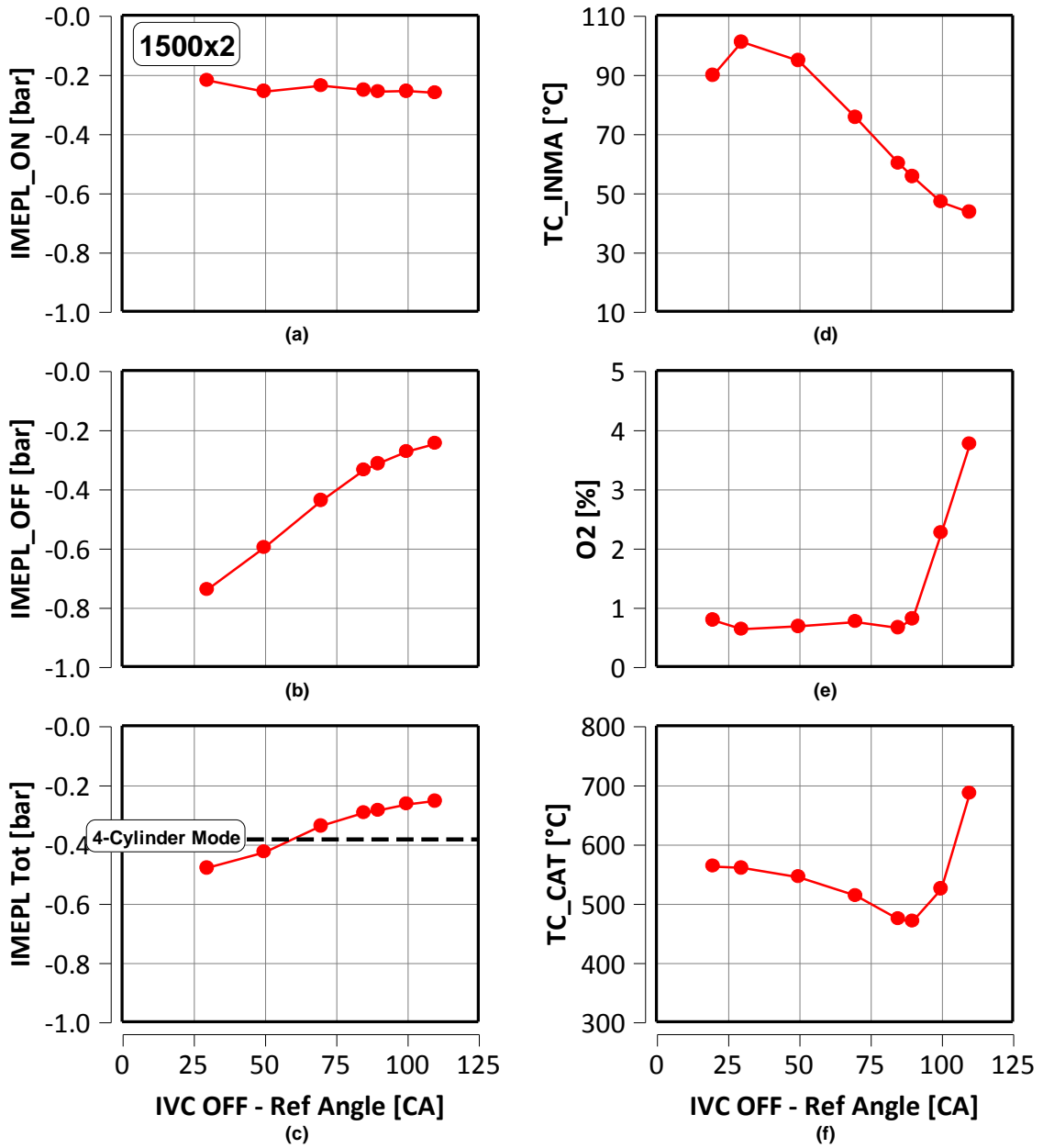

Figure 4.7. 1500x2, IVC optimization for the inactive cylinders. IVC expressed as a distance from a reference angle. Active cylinders pumping losses (a), inactive cylinders pumping losses (b), total pumping losses (c), intake manifold temperature (d), O₂ volume concentration in the exhaust line before catalyst (e), monolith catalyst temperature (f)

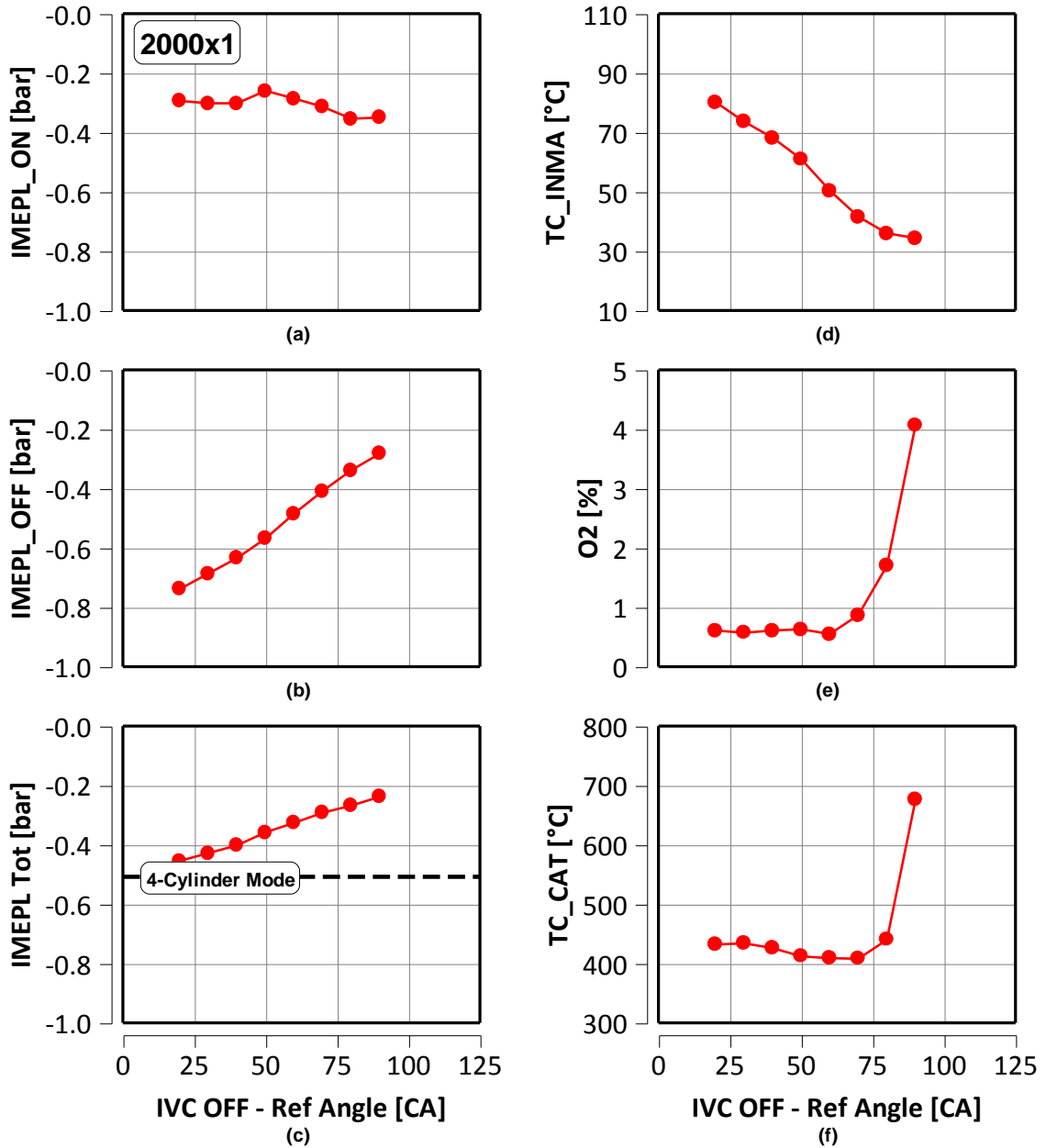

Figure 4.8. 2000x1, IVC optimization for the inactive cylinders. IVC expressed as a distance from a reference angle. Active cylinders pumping losses (a), inactive cylinders pumping losses (b), total pumping losses (c), intake manifold temperature (d), O₂ volume concentration in the exhaust line before catalyst (e), monolith catalyst temperature (f)

When the IVC is not set to recirculate all the EGR extracted from the exhaust manifold some EGR is pushed in the intake manifold causing the temperature increase of the fresh charge TC_INMA (see Figure 4.7d): this EGR will be recirculated in the active cylinders in the subsequent cycles.

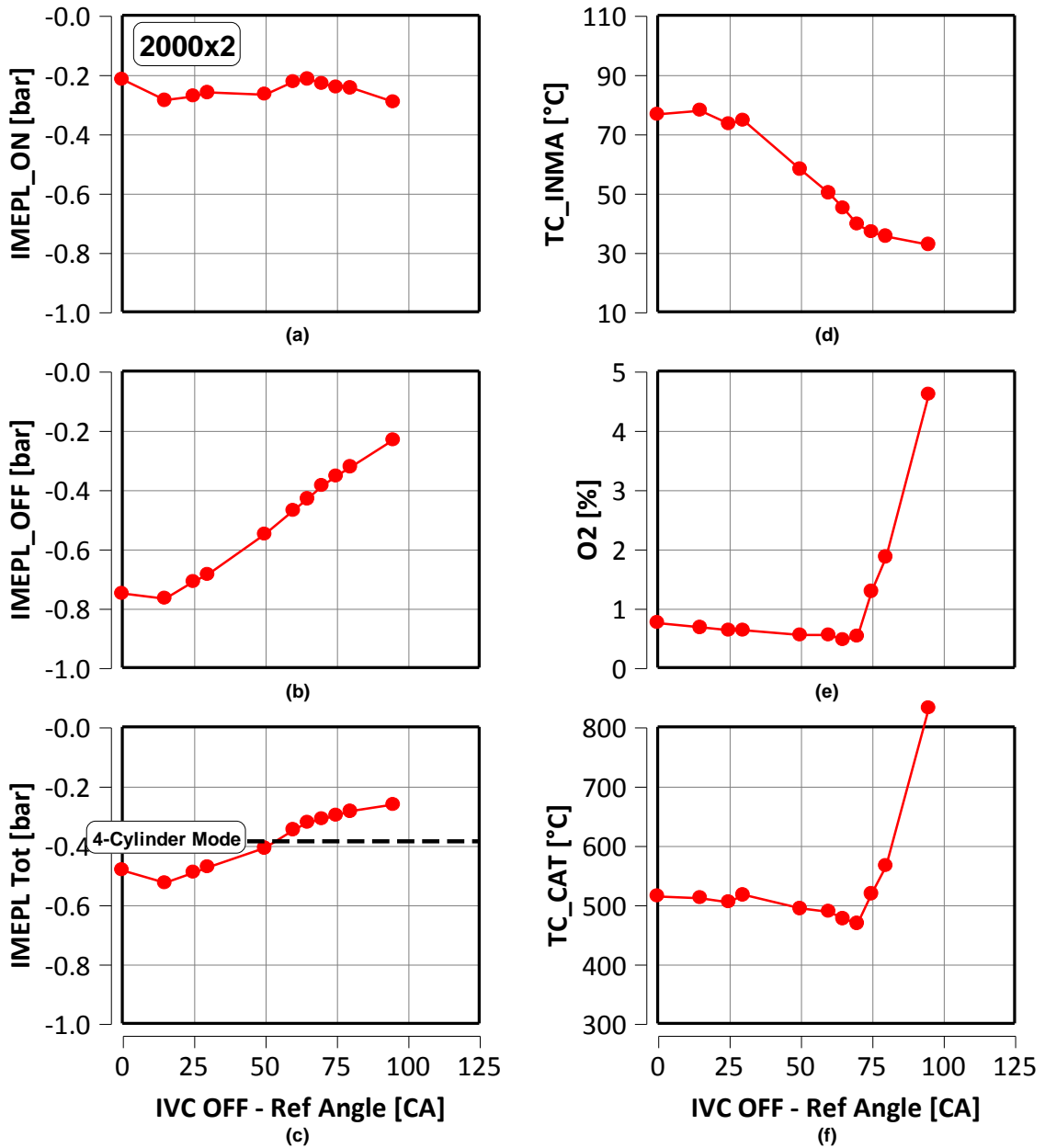

Figure 4.9. 2000x2, IVC optimization for the inactive cylinders. IVC expressed as a distance from a reference angle. Active cylinders pumping losses (a), inactive cylinders pumping losses (b), total pumping losses (c), intake manifold temperature (d), O₂ volume concentration in the exhaust line before catalyst (e), monolith catalyst temperature (f)

Furthermore, it has to be pointed out that the introduction of O₂ in the exhaust is sensed by an exhaust gas analyser but it can also be detected through the analysis of the monolith catalyst temperature. Since the lambda control of the ECU keeps the total A/F at the stoichiometric value, the O₂ introduced in the inactive cylinders reacts with the enriched mixture of the active cylinders in the catalyst, causing a temperature increase.

Finally, it can be noticed that in the optimal point (IVC OFF = 80CA) the IMEP Total is lower than the 4-cylinder case, and therefore an efficiency enhancement is obtained.

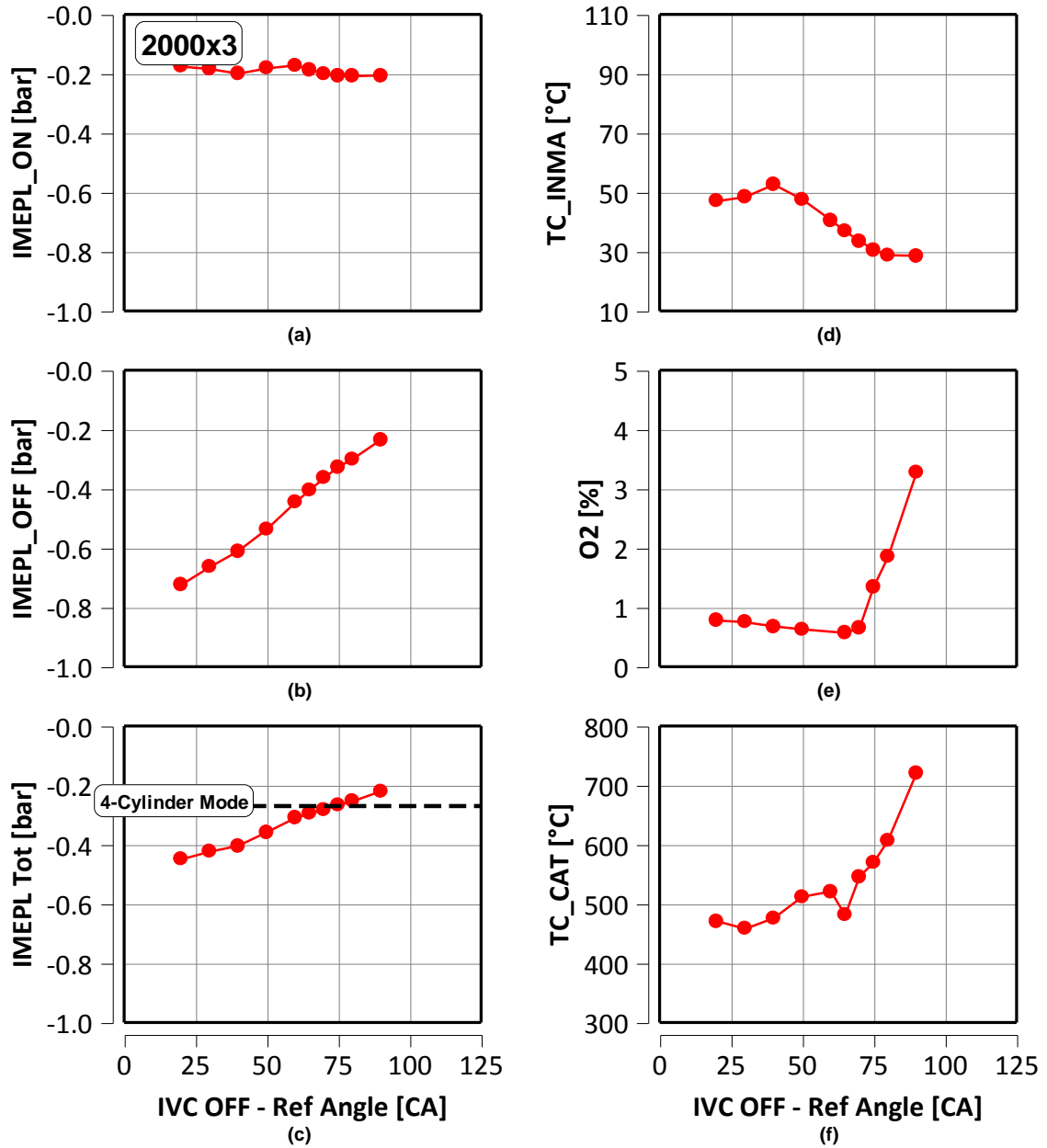

Figure 4.10. 2000x3, IVC optimization for the inactive cylinders. IVC expressed as a distance from a reference angle. Active cylinders pumping losses (a), inactive cylinders pumping losses (b), total pumping losses (c), intake manifold temperature (d), O_2 volume concentration in the exhaust line before catalyst (e), monolith catalyst temperature (f)

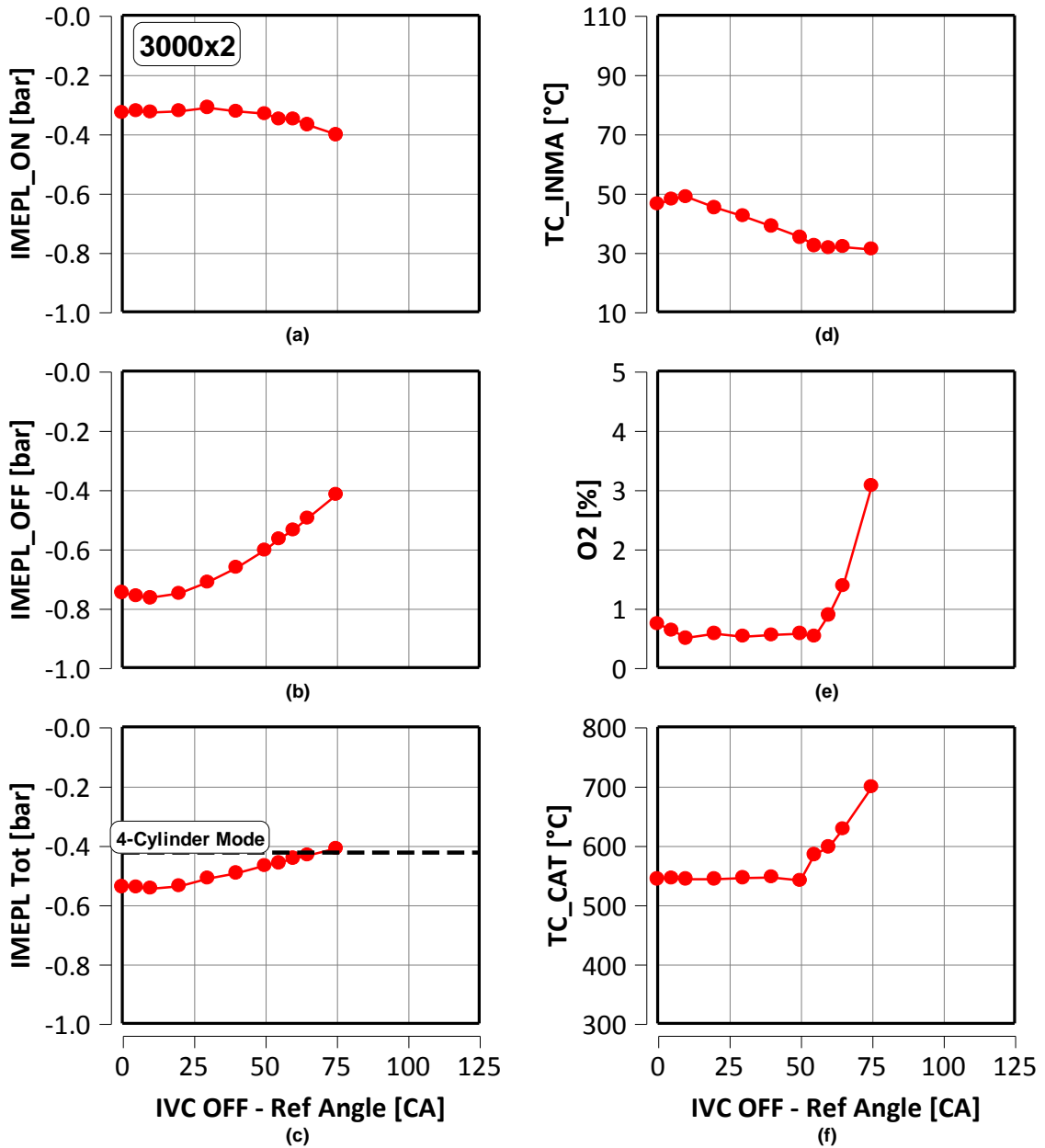

Figure 4.11. 3000x2, IVC optimization for the inactive cylinders. IVC expressed as a distance from a reference angle. Active cylinders pumping losses (a), inactive cylinders pumping losses (b), total pumping losses (c), intake manifold temperature (d), O₂ volume concentration in the exhaust line before catalyst (e), monolith catalyst temperature (f)

As the speed increases the EGR is extracted from the exhaust manifold with a lower flow coefficient across the valves, and therefore its quantity is decreased and the IVC OFF to be used to avoid O₂ introduction is more advanced.

Considering the speed section at 2 bar the optimal IVC OFF is 80 CA, 75 CA and 50 CA at 1500rpm, 2000rpm and 3000rpm respectively (see Figures 4.7-4.9-4.11 e), resulting in lower IMEPL OFF levels at 3000rpm. This effect is also evident in the trends of the TC_INMA, since its rise with IVC is less pronounced for increasing engine speed (see Figures 4.7-4.9-4.11 d).

On the load section at constant speed (see Figures 4.8-4.9-4.10) the optimal IVC OFF is almost the same for the analysed engine loads: the IMEPL of the 4-cylinder mode increases with the engine load because it is possible to recirculate an EGR quantity that allows IMEPL similar to the modularity actuation (see Figure 4.10c).

From the analysis at part load it can therefore be concluded that the displacement modularity is effective only in the low engine speed/load region; the effect in reducing the pumping loss is significant at the lowest load and then decreases as the load increases. The break-even point in terms of load is at 3 bar BMEP at 2000rpm and at 2 bar BMEP at 3000rpm. Since the selected engine operating points at 1500 and 2000rpm are representative of the NEDC cycle for a vehicle of the C segment, the displacement modulation represents an effective strategy to further reduce the fuel consumption.

CHAPTER 5

EFFECT OF LIVC ON KNOCK MITIGATION

In this section the experimental investigation on the Late Intake Valve Closing in a turbocharged gasoline engine equipped with a VVA system is presented.

The LIVC strategy coupled with a VVA system allows a flexible and cycle by cycle regulation of the effective compression ratio and therefore a sensitive mitigation of knocking occurrence. However the LIVC leads to a decrease in the volumetric efficiency that has to be compensated by an increase of the boost pressure in order to obtain the same torque output.

The activity has been carried out designing and testing a specific intake cam lobe able to perform extreme late closures. Although the high load region is less significant for the CO₂ reduction in the NEDC cycle, it is more representative of the real life engine operation, where calibration actions which are usually required to avoid knock (such as mixture enrichment and spark timing retard) can provoke a dramatic drop in the fuel conversion efficiency. Moreover, knock mitigation could also allow the adoption of a higher geometrical compression ratio at the design stage, with obvious benefits in terms of fuel economy over the entire engine operating map.

The output of the experimental analysis is a significant reduction in fuel consumption for the high load engine operating points, especially at high engine speed where the turbocharger group is capable to compensate through an increase of the boost pressure the decreased volumetric efficiency of the LIVC strategy.

5.1 LIVC PRINCIPLES

The LIVC strategy coupled with a VVA system allows a flexible and cycle by cycle regulation of the effective compression ratio (as shown in Figure 5.1) and therefore a sensitive mitigation of knocking phenomena. However the LIVC leads to a decrease in the volumetric efficiency that has to be compensated by the turbocharger in order to obtain the same engine torque output. The effects of the LIVC actuation at high engine loads are the following:

- More efficient combustion phasing due to knocking mitigation;
- Pumping loss reduction due to the increased boost pressure to compensate the loss in volumetric efficiency.

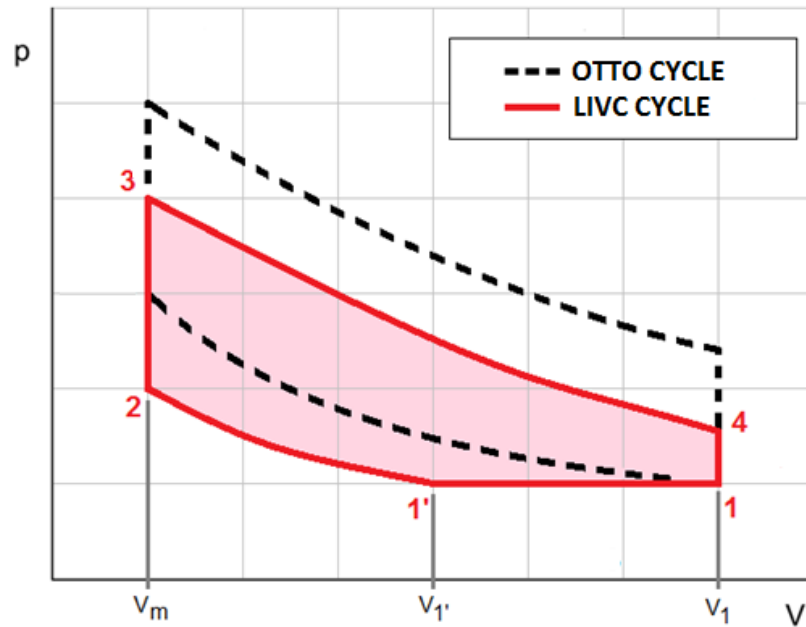

Figure 5.1. Scheme of Otto cycle and LIVC Cycle

The advancing of combustion phasing which is made possible by knock mitigation leads to lower exhaust temperatures, requiring more moderate fuel enrichment in order to contain the exhaust temperatures at turbine inlet. Even if the thermodynamic efficiency of the LIVC cycle is reduced, due to the lower effective compression ratio, the pumping loss reduction partially compensates this effect.

Although the compression ratio control could also be performed with an EIVC strategy, the LIVC was selected because is more effective in knocking mitigation. This is probably due to the better fuel-air mixing and to the higher turbulence intensity that the LIVC allows. As a matter of fact the EIVC strategy involves a charge expansion from the EIVC to

the BDC, and therefore during this phase the in-cylinder temperature drops down and may hinder fuel vaporization. On the other hand with the LIVC the in cylinder temperatures are at a constant level, thus guarantying a better fuel-air mixing. These considerations find the experimental evidence at 2500x19 (see Figure 5.2, where the IVC is referred to the maximum volumetric efficiency angle) where the LIVC actuation gives the possibility to run the engine with a more advanced MFB 50% (see Figure 5.2b) and also with a leaner mixture. In this sweep of IVC the Lambda is regulated in order to contain the turbine inlet temperature at 950 °C (see Figure 5.2c and d), since it is the thermo-structural limit of the turbine wheel.

At part load the LIVC is not effective on this PFI engine because of the excessive backflow in the intake manifold. Since the part load requires extreme late valve closures, and the PFI system does not allow in the cylinder injection when the intake valves are closed, the injected fuel flows in the intake manifold. Nevertheless the mixing in the intake manifold is not uniform, and the fuel back-flow in the intake manifold provokes high cylinder to cylinder lambda variations that negatively affect the combustion stability and the fuel consumption.

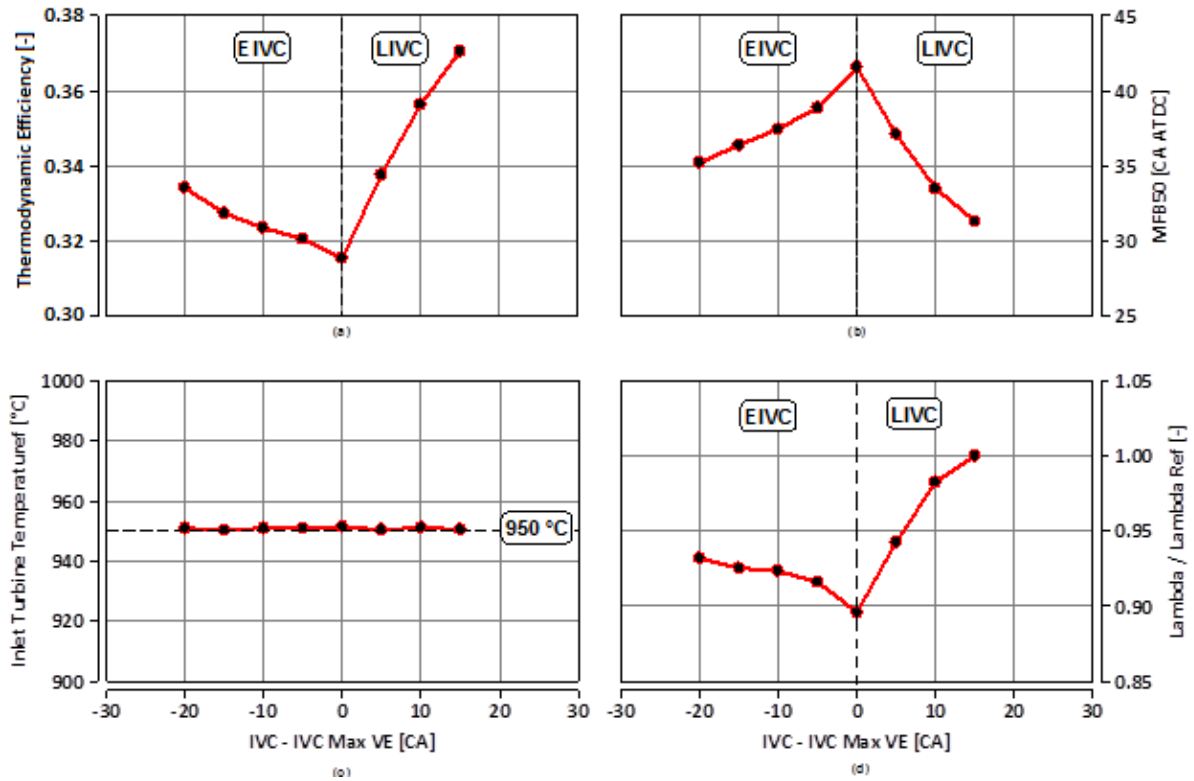

Figure 5.2. IVC effect at 2500x19, IVC is referred to the maximum volumetric efficiency. Thermodynamic efficiency (a), MFB 50% (b), Inlet Turbine Temperature (c), Lambda normalized to a reference value (d).

5.2 EXPERIMENTAL SETUP

The test engine is a Fiat MultiAir Fire 1.4 litre, turbocharged and Port Fuel Injected (PFI), the main features of which are listed in Table 3.1. It is the same used in the analysis of the displacement modularity presented in the chapter 4. A specific intake cam lobe was designed in order to perform extreme late closures. While the NP (Normal Production) intake cam profile was designed to optimize the volumetric efficiency at 5500 rpm that is the full rated power point of the tested engine, the extreme late cam lobe allows a complete LIVC regulation with a maximum IVC equal to the combustion TDC (as shown in Figure 5.3).

The experimental comparison has been carried out comparing the optimal IVC with the NP cam IVC. Due to the dynamic response of the electrohydraulic VVA system the maximum IVC of the NP intake cam increases for increasing speed and is reported in the table 5.1.

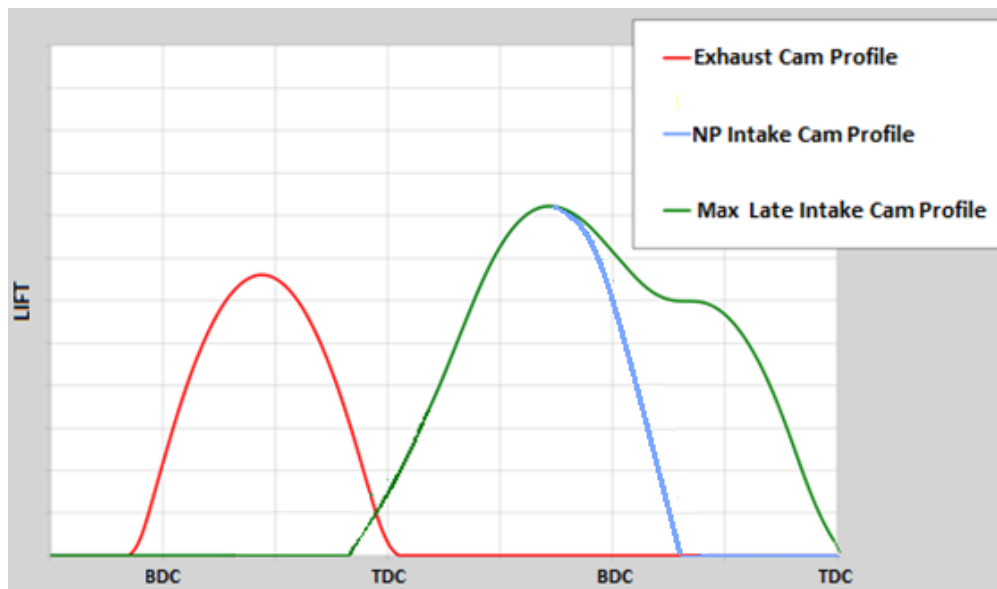

Figure 5.3. Exhaust and Intake cam profile tested

Table 5.1. NP Cam IVC as a function of engine speed

Engine Speed	IVC
rpm	CA ABDC
1750	54
2000	54
2500	55
3000	57
4000	63
5000	65

5.3 EXPERIMENTAL ANALYSIS

The experimental activity was focused on the comparison between the Max Late and the NP profile on a load section from 14 to 20 bar BMEP carried out at different engine speeds: 1750rpm, 2000rpm, 2500rpm, 3000rpm, 4000rpm and finally 5000rpm (see Figure 5.4). The aim was to catch the effect of engine speed and of the boost pressure availability on the optimal LIVC. Since the 1500rpm has a full rated load of 13 bar it was discarded from the experimental analysis because it was not affected by intense knocking. The testing activity has been carried out with the following limitations in order to prevent from damaging the turbocharger, the exhaust and the intake line:

- turbocharger wheel angular speed: 240 000 rpm;
- in cylinder pressure: 85 bar;
- absolute boost pressure: 2500 mbar;
- inlet turbine temperature: 950°C;
- SA knock limited.

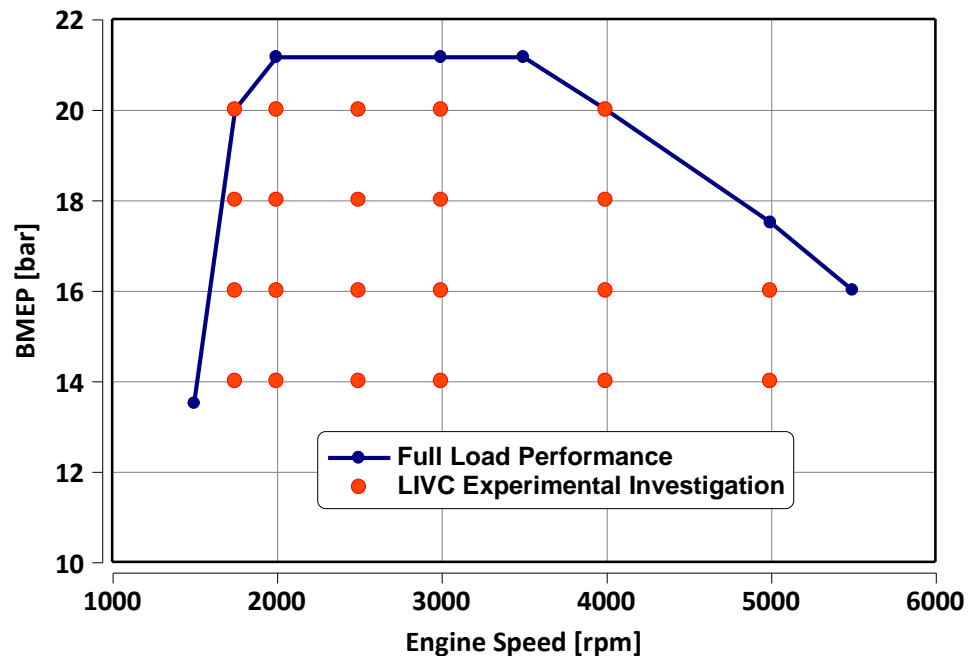

Figure 5.4. LIVC Experimental investigation area.

Since the engine low-end torque is almost limited at 1750rpm (i.e. below this speed the engine torque drops dramatically) this engine speed was firstly investigated with the LIVC strategy. Due to the low engine speed and the high BMEP it is therefore obviously critical for knock, thus requiring the highest retard of the spark timing with respect to the other engine

speeds. Therefore a possible knock mitigation could provide significant benefits. Since the LIVC strategy strictly depends on the turbocharger capability to compensate for the decreased volumetric efficiency, at low engine speed only a moderate LIVC can be applied, while at high rotational speed the LIVC is limited by the need to avoid exceeding the maximum values of the boost pressure, of the angular speed of the turbocharger wheel and of the in-cylinder pressure.

The experimental investigation on LIVC effect at different engine loads consisted in LIVC sweeps in which the engine load is regulated in W.O.T. through the boost pressure and thus through the turbocharger waste gate. The intake cam used in the IVC sweeps is the Max late profile; in order to have a comparison with the base configuration, each IVC sweep contains the IVC of the NP cam reported in the table 5.1. The most important parameter used in the evaluation of the intake profiles is the so called *Thermodynamic efficiency*. It is calculated as:

$$\textit{Thermodynamic Efficiency} [-] = \frac{\textit{Net Indicated Power [kW]}}{\textit{Fuel Consumption [kg/h]} * \textit{LHV[kJ/Kg]}} ;$$

where the Net Indicated Power is calculated from the four in-cylinder pressure signals over the entire engine cycle and LHV is the Low Heating Value of the fuel.

As can be easily seen the thermodynamic efficiency allows to evaluate the effect of the combustion phasing, the pumping losses and also the combustion efficiency. The latter can play an important role at high engine speed when substantial mixture enrichment could be used to limit the inlet turbine temperatures.

5.3.1 LIVC TEST RESULTS SUMMARY

The main results of the LIVC strategy consisted in a significant enhancement in thermodynamic efficiency especially in the high speed and load points that have been investigated (see Figure 5.5). Although the high knock sensitivity, at low engine speed (i.e. 1750rpm and 2000rpm) the turbocharger capability is not sufficient to support extreme late IVC. Nevertheless at 2000x16 and 18 it is possible to delay the IVC from 54 to 66 CA ABDC and 63 CA ABDC respectively (see Table 5.2). Since the combustion is advanced (see the MFB50% in the Table 5.2), the thermodynamic efficiency increases of 2.7% at 2000x14 and 1.4% at 2000x16.

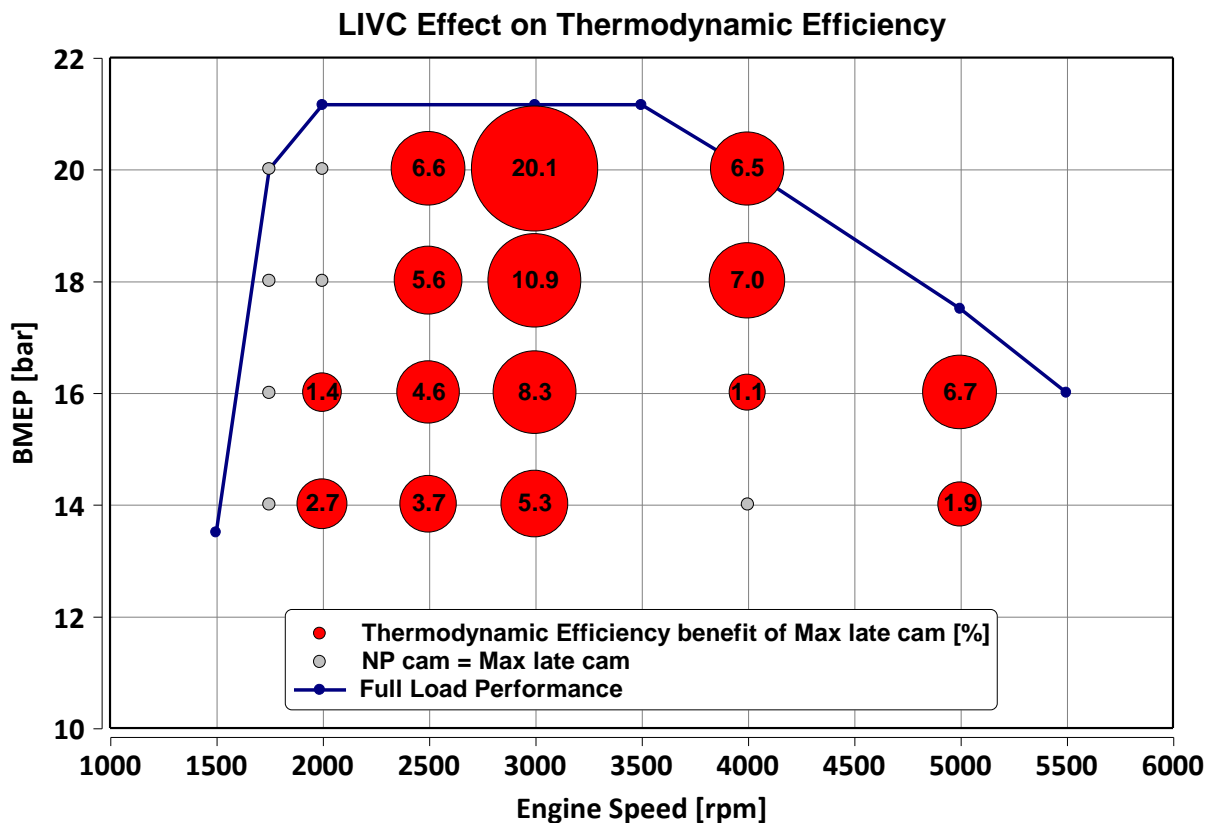

Figure 5.5. LIVC effect on thermodynamic efficiency.

The LIVC strategy begins to be effective at 2500rpm, where along the load section the benefit ranges from 3.7% to 6.6% and the optimal IVC is set at about 30 CA later than the NP cam. However the highest impact is registered at 3000x18 and 20 (see Figure 5.5), in which the LIVC allows to run the engine operating points under stoichiometric conditions. As a matter of fact, due to the delayed combustion, the NP cam requires Lambda equal to 0.95 at

3000x18 and 0.87 at 3000x20 in order to cool down the inlet turbine temperatures (see Table 5.2).

At 4000rpm the Max late profile has less important effects because the knocking occurrence is partially mitigated by the increased engine speed. At 14 bar BMEP it is not necessary to further advance the combustion phasing in order to increase the thermodynamic efficiency. The fuel economy given at 4000x18 and 4000x20 is due to the leaner mixture (see Table 5.2) required to limit the inlet turbine temperature at 950°C.

Similar remarks can be done at 5000rpm, in which the exhaust temperatures become more critical with respect to 4000rpm. As a matter of fact at 14 bar BMEP a Lambda set at 0.93 is required, while at 4000rpm the mixture is stoichiometric until 18 bar BMEP. However, although the Max late cam does not allow to run in stoichiometric conditions a substantial leaner mixture can be applied with respect to the NP cam (see again Table 5.2).

Table 5.2. LIVC main results

Engine Speed [rpm]	BMEP [bar]	NP Intake Cam			Max Late Intake Cam					
		IVC [CA ABDC]	Lambda [-]	MFB 50% [CA ATDC]	Therm. Efficiency [-]	IVC [CA ABDC]	Lambda [-]	MFB 50% [CA ATDC]	Therm. Efficiency [-]	Δ Therm. Efficiency [%]
1750	14	54	1	20	0.375	54	1	20	0.375	0.0
	16	48	1	24	0.360	48	1	24	0.360	0.0
	18	44	1	30	0.340	44	1	30	0.340	0.0
	20	42	1	35	0.330	42	1	35	0.330	0.0
2000	14	54	1	17	0.370	66	1	14	0.380	2.7
	16	54	1	24	0.365	63	1	22	0.370	1.4
	18	54	1	28	0.353	54	1	28	0.353	0.0
	20	54	1	32	0.340	54	1	32	0.340	0.0
2500	14	55	1	16	0.383	83	1	9	0.397	3.7
	16	55	1	23	0.373	82	1	14	0.390	4.6
	18	55	1	27	0.360	81	1	18	0.380	5.6
	20	55	1	30	0.347	79	1	24	0.370	6.6
3000	14	57	1	16	0.374	104	1	9	0.394	5.3
	16	57	1	22	0.360	102	1	13	0.390	8.3
	18	57	0.95	25	0.340	100	1	20	0.377	10.9
	20	57	0.87	28	0.308	90	1	22	0.370	20.1
4000	14	63	1	12	0.380	90	1	11	0.380	0.0
	16	63	1	18	0.371	90	1	16	0.370	-0.3
	18	63	0.9	19	0.330	89	0.97	19	0.353	7.0
	20	63	0.86	21	0.310	88	0.89	19	0.330	6.5
5000	14	65	0.93	14	0.360	110	1	13	0.367	1.9
	16	65	0.84	18	0.300	110	0.89	15	0.320	6.7

5.3.2 LOAD SECTIONS ANALYSIS

The IVC sweep investigation begun with the 1750rpm, which is the most critical speed for knocking sensitivity. At 1750 x14 the positive effect of LIVC is shown in the Figures 5.6-5.7-5.8; the LIVC set at 54 CA ABDC leads to an enhancement of the thermodynamic efficiency of 13.7% (as it is shown in Figure 5.6a). In this point the turbocharger waste gate is completely closed and therefore no more boost pressure is available to further delay the IVC; as a matter of fact at IVC 67 CA ABDC only 11.8 bar BMEP can be reached (see Figure 5.6c).

Along the IVC sweep, despite the significant drop in volumetric efficiency, the boost pressure which is necessary to keep the same BMEP level rises of only 50 mbar due to the significant increase in the thermodynamic efficiency (see Figure 5.6d). Since the effective compression ratio passes from 10 to 8.9 the knocking sensitivity is mitigated, and the combustion phasing is advanced with a rise in MFB 50% of 3.5 CA (see Figure 5.7c). The Lambda is not enriched since the inlet turbine temperature does not overcome its threshold value and no pre-ignition of the mixture before the SA were registered.

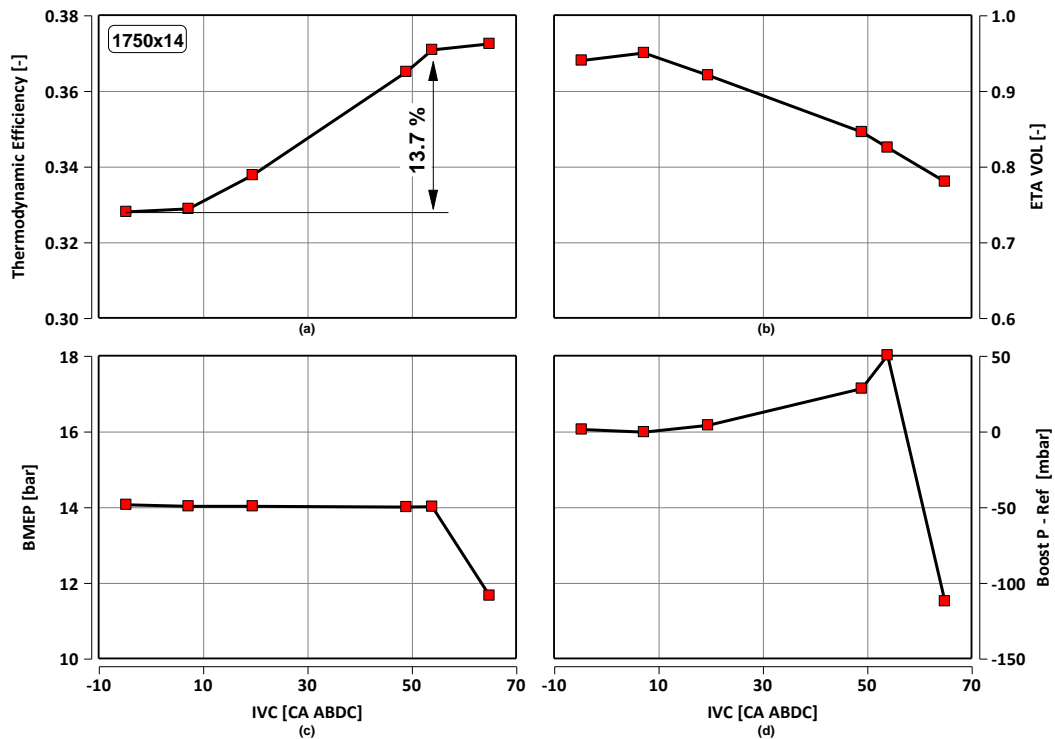

Figure 5.6. LIVC effect on thermodynamic efficiency (a), volumetric efficiency (b), BMEP (c) and boost pressure referred to the value of the maximum volumetric efficiency (d) - 1750rpm x 14bar BMEP

The advanced combustion phasing for increasing IVC has positive effects also on combustion stability (see Figure 5.8 left); nevertheless the combustion durations are not

remarkably affected, and only the MFB5-50% has a slight decrease for delayed IVC from 13 to 11 CA (see Figure 5.8 right).

As a conclusion, at 1750x14 the LIVC allows significant increase in thermodynamic efficiency; however the turbocharger is not capable to support LIVC angles higher than the NP cam (see table 5.1) making the Max late cam not effective at this engine speed.

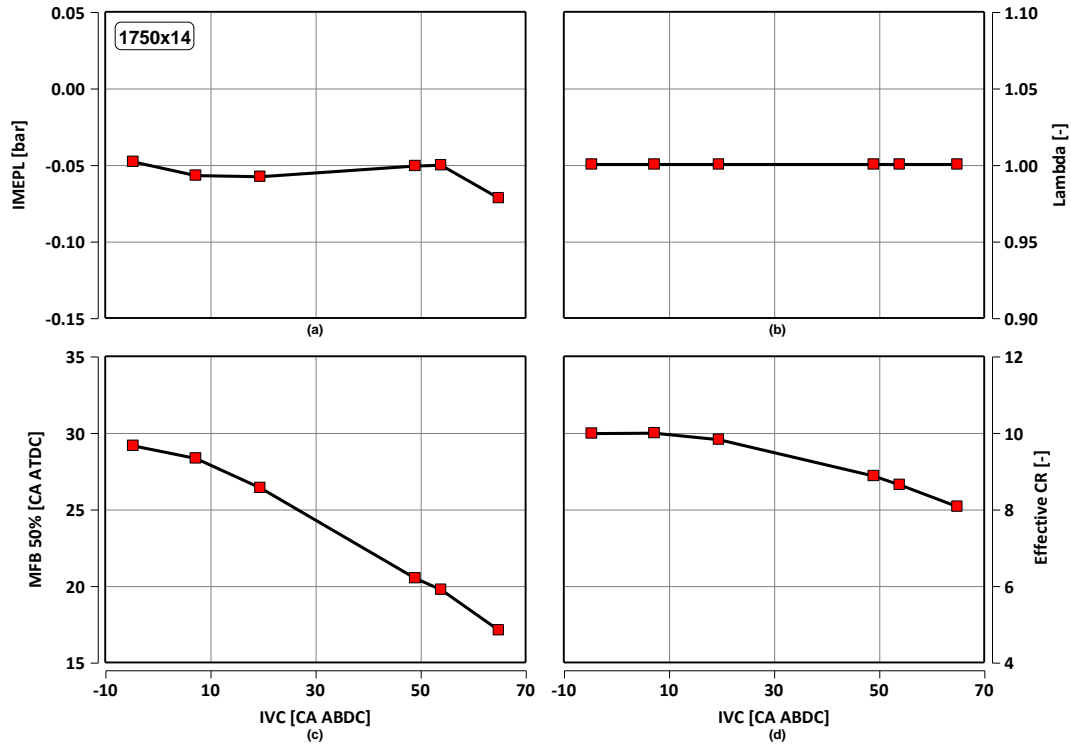

Figure 5.7. LIVC effect on IMEPL (a), Lambda (b), peak angle of the in-cylinder pressure (c) and effective compression ratio (d) - 1750rpm x 14bar BMEP.

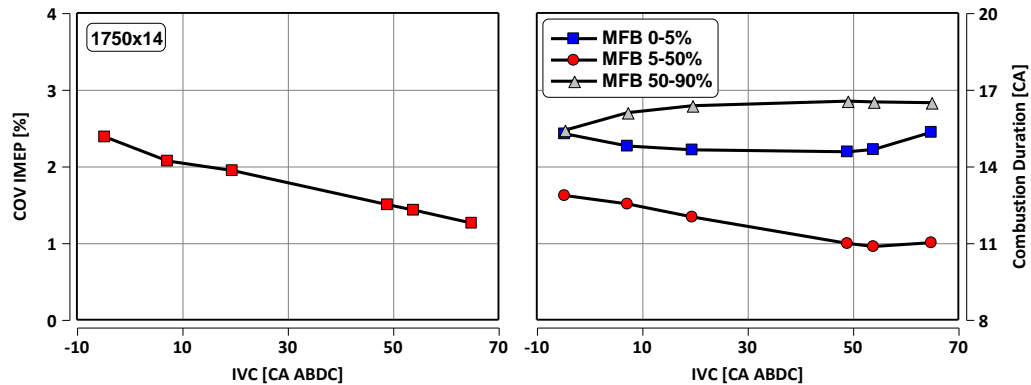

Figure 5.8. LIVC effect on COV IMEP (left), combustion durations (right) - 1750rpm x 14bar BMEP.

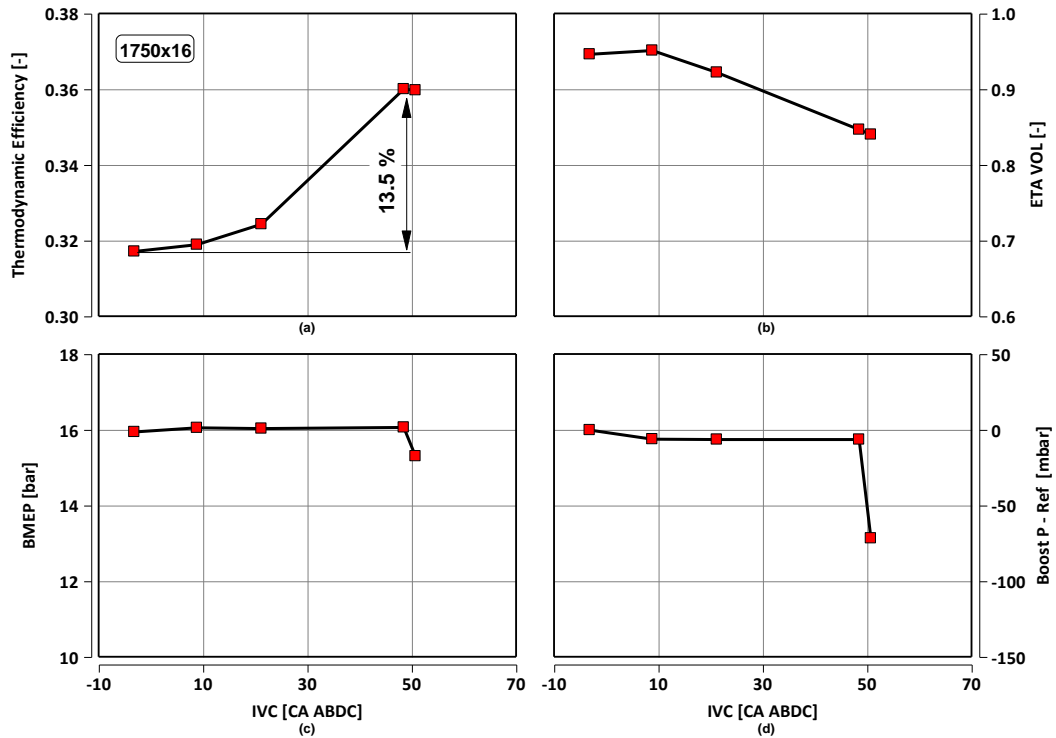

Figure 5.9. LIVC effect on thermodynamic efficiency (a), volumetric efficiency (b), BMEP (c) and boost pressure referred to the value of the maximum volumetric efficiency (d) - 1750rpm x 16bar BMEP.

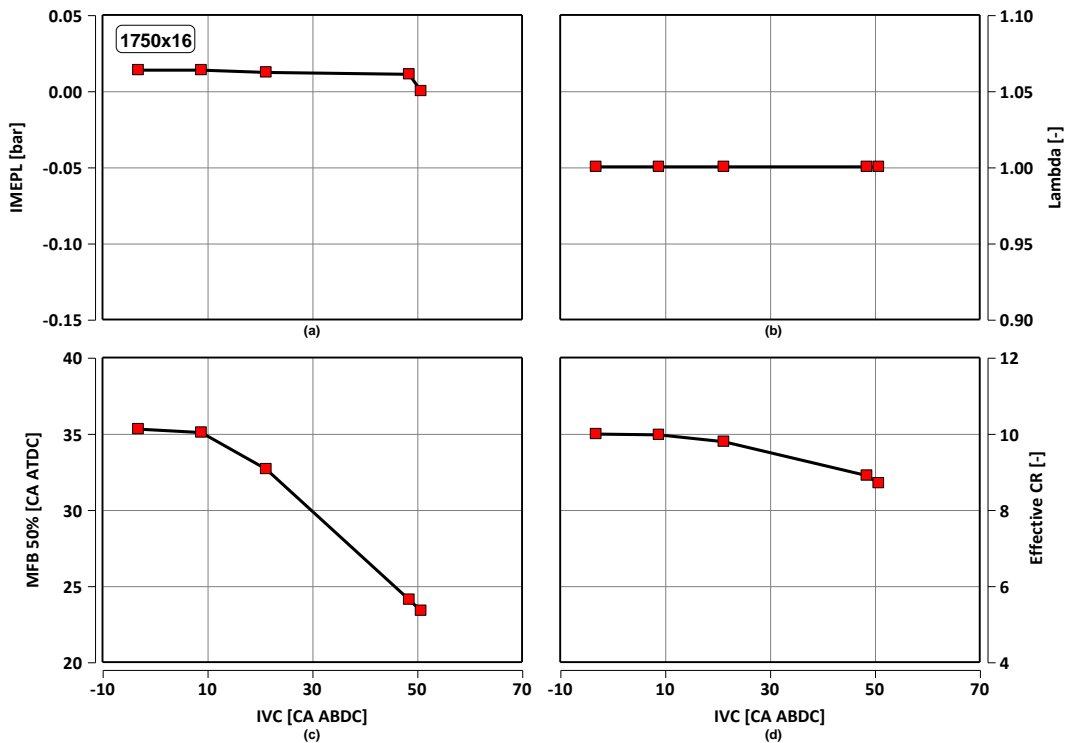

Figure 5.10. LIVC effect on IMEPL (a), Lambda (b), peak angle of the in-cylinder pressure (c) and effective compression ratio (d) - 1750rpm x 16bar BMEP.

Since at 1750x14 the optimal point is IVC=54CA ABDC and the waste gate is completely closed, for increasing load the IVC has to be more advanced in order to realize the BMEP target through an increase of both volumetric efficiency and boost pressure. At 1750x16 the optimal IVC is 48 CA ABDC, with a benefit of 13.5% in thermodynamic efficiency. Despite the reduced volumetric efficiency, the boost pressure does not rise along the IVC sweep due to the significant increase in the thermodynamic efficiency that allows to meet the 16 bar BMEP target (see Figure 5.9d). The optimal MFB 50% is 24 CA ATDC, which is 4 CA more delayed than the 1750x14, due to the high knocking occurrence at the same combustion phasing (compare Figure 5.10d with Figure 5.7c). Finally the combustion stability and the combustion durations have similar trends with respect to the 1750x14 (see Figure 5.11).

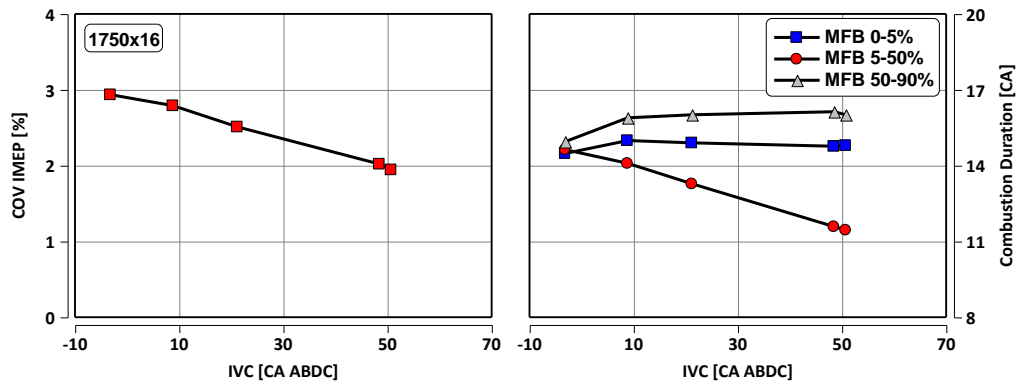

Figure 5.11. LIVC effect on COV IMEP (left), combustion durations (right) - 1750rpm x 16bar BMEP.

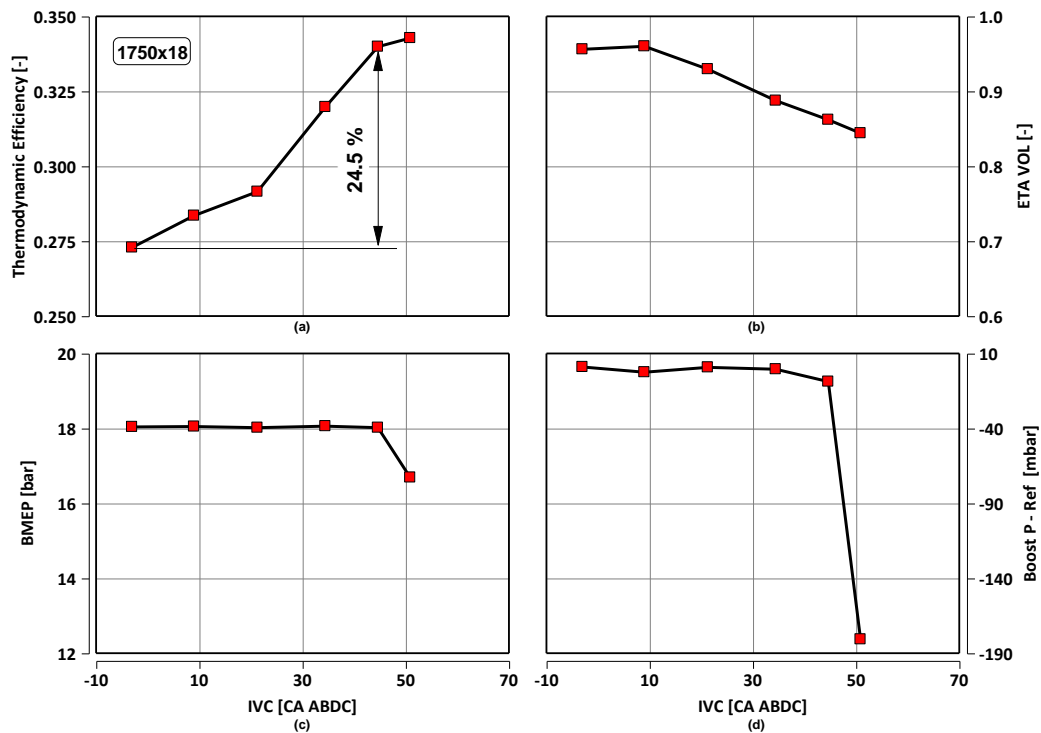

Figure 5.12. LIVC effect on thermodynamic efficiency (a), volumetric efficiency (b), BMEP (c) and boost pressure referred to the value of the maximum volumetric efficiency (d) - 1750rpm x 18bar BMEP.

Even if the absolute values are different, at 1750x18 and 1750x20 the effect of LIVC on thermodynamic efficiency is similar and the optimal IVC allows a benefit of 24%, with respect to the maximum volumetric efficiency point. The MFB 50% are 30 and 35 CA respectively (see Figure 5.13c and Figure 5.16c) and the volumetric efficiency, in the optimal points, ranges from 0.87 to 0.88 (see Figure 5.12b and Figure 5.15b).

Differently from the 14 and 16 bar BMEP, at 18 and 20 bar BMEP the air to fuel ratio is enriched in order to avoid the auto-ignition of the mixture before the spark advance. Since this phenomenon happens when the combustion is remarkably delayed, it is necessary to enrich the mixture in order to cool down the in-cylinder temperatures (see Figure 5.13b and Figure 5.16b). For increasing IVC the combustion phasing is more and more advanced and leaner mixture can be set without the auto-ignition of the mixture; moreover in the optimal IVC it is possible to run the engine in stoichiometric conditions, thus amplifying the effect on the fuel economy. Finally the positive effect of LIVC on combustion stability is also confirmed in these engine points (see Figure 5.14 left and Figure 5.17 left).

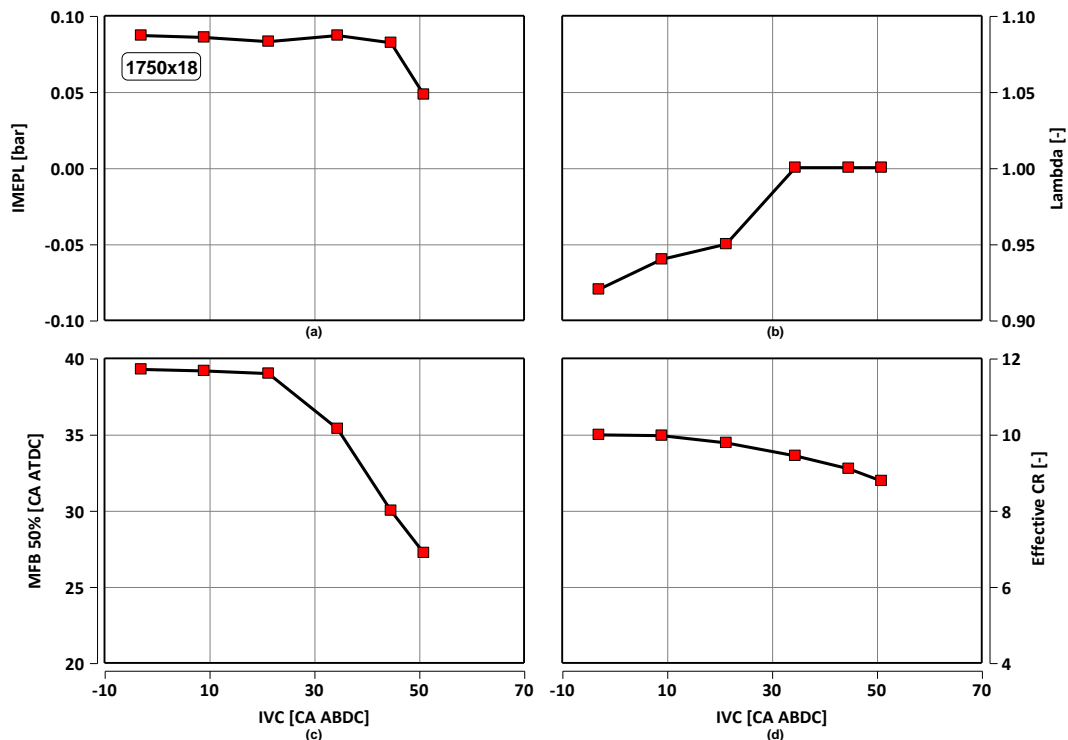

Figure 5.13. LIVC effect on IMEPL (a), Lambda (b), peak angle of the in-cylinder pressure (c) and effective compression ratio (d) - 1750rpm x 18bar BMEP.

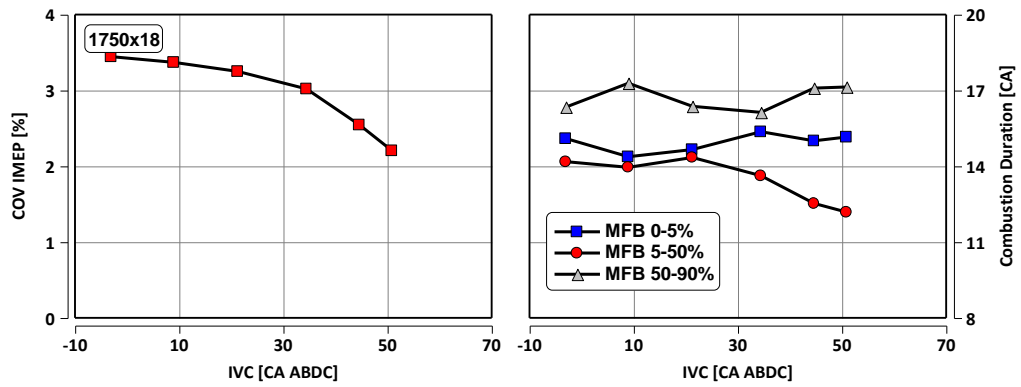

Figure 5.14. LIVC effect on COV IMEP (left), combustion durations (right) - 1750rpm x 18bar BMEP.

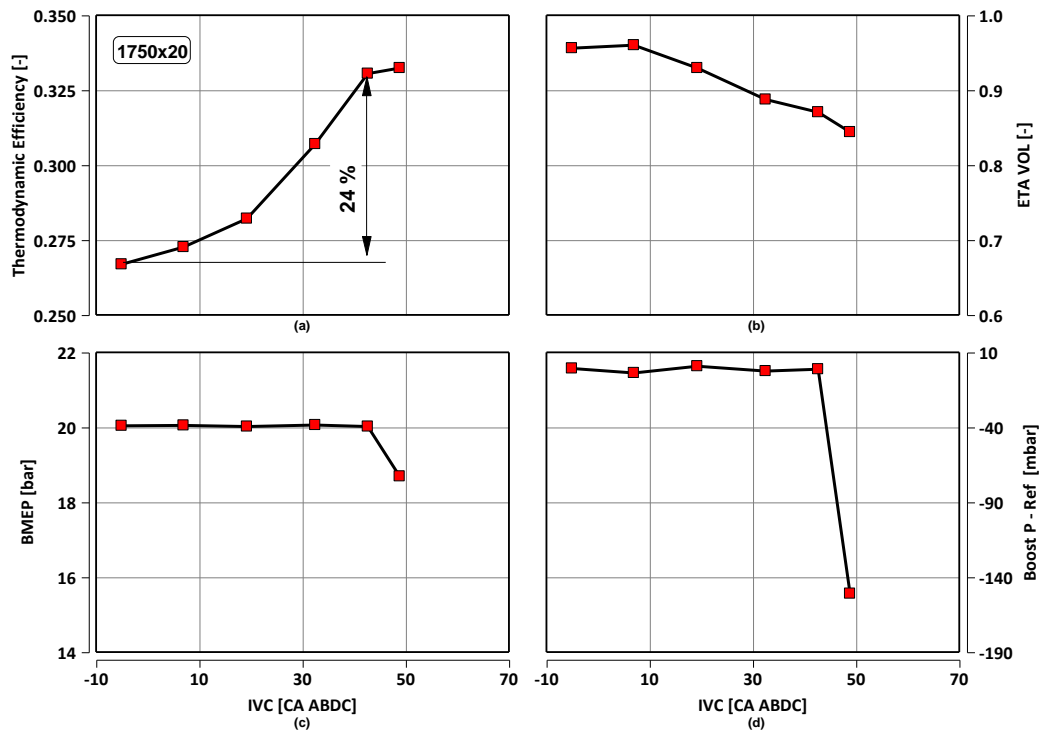

Figure 5.15. LIVC effect on thermodynamic efficiency (a), volumetric efficiency (b), BMEP (c) and boost pressure referred to the value of the maximum volumetric efficiency (d) - 1750rpm x 20bar BMEP.

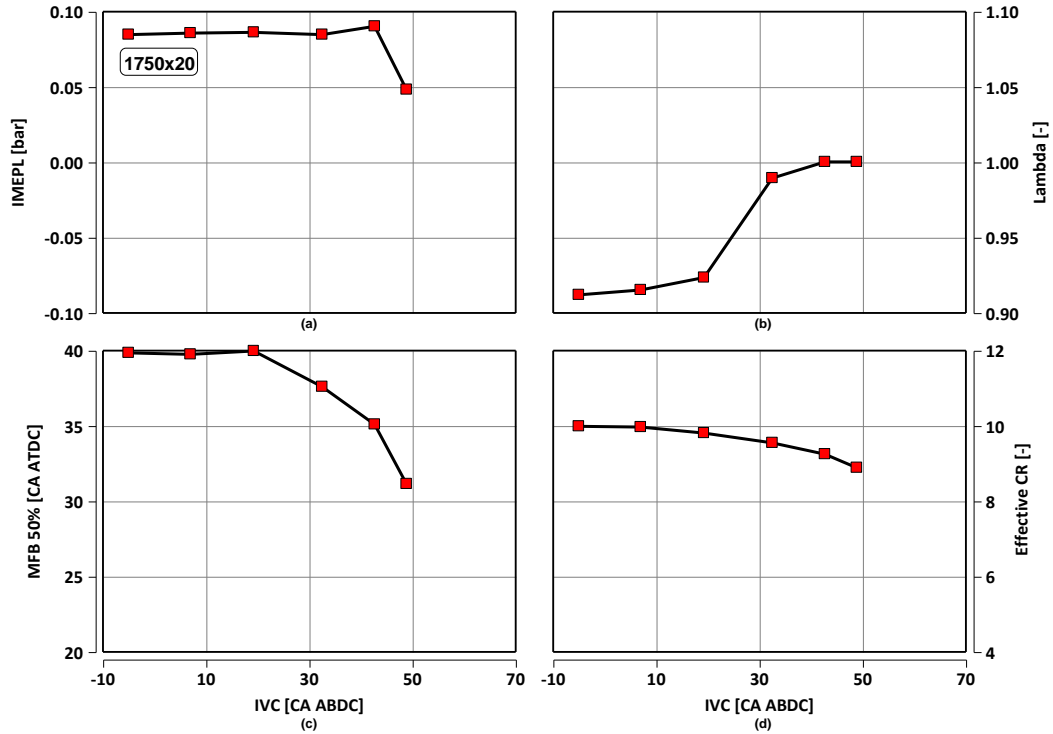

Figure 5.16. LIVC effect on IMEPL (a), Lambda (b), peak angle of the in-cylinder pressure (c) and effective compression ratio (d) - 1750rpm x 20bar BMEP.

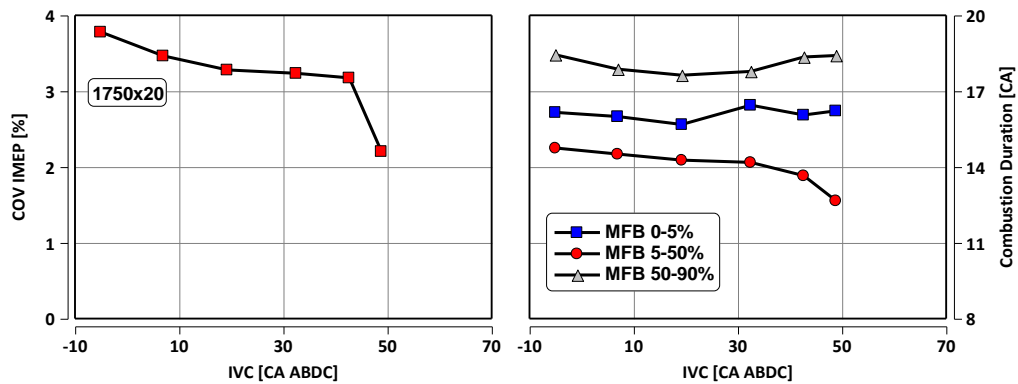

Figure 5.17. LIVC effect on COV IMEP (left), combustion durations (right) - 1750rpm x 20bar BMEP.

At 2000rpm the turbocharger response is not remarkably different from the 1750rpm, and it is possible to use the Max late cam only at 14 and 16 bar BMEP (see Figure 5.18a and Figure 5.21a). While the NP cam allows 54 CA ABDC of IVC, the optimal IVC are 66 and 63 CA ABDC at 14 and 16 bar BMEP respectively. In these points the thermodynamic efficiency rises of 2.7% and 1.4% thanks to a more advanced MFB 50%. While at 14 bar BMEP the MFB 50% reduces from 17 to 14 CA ATDC (see Figure 5.19c, from IVC 54 to IVC 66 CA ABDC), at 16 bar BMEP the MFB 50% is reduced from 24 to 22 CA ATDC (see Figure 5.22c, from IVC 58 to IVC 63 CA ABDC).

At 16 bar BMEP the advantage is less pronounced than 14 bar BMEP because the IVC is set to 63 CA ABDC. As a matter of fact is possible to use the Extreme late cam just for 9 CA later than the NP cam. Since the Extreme late cam is characterized by a lower volumetric efficiency, the boost pressure is increased of 67 mbar at 14 bar BMEP and 78 mbar at 16 bar BMEP (see Figure 5.18d and 5.21d). Along the load sweep the inlet turbine temperature does not reach its threshold value, moreover no auto-ignition occurs, and thus the fuel air mixture is not enriched.

Regarding the 2000x18 and 2000x20, even if the turbine waste gate is completely closed, the IVC required to reach the target load are 54 and 52 CA ABDC thus making the Max late cam not effective (see Figure 5.24a and Figure 5.27a). The trends of the above mentioned parameters are similar between the 1750rpm and the 2000rpm load section; in the latter case it is easy to note that the knocking is mitigated for increasing speed, thus allowing more advanced MFB 50%, higher thermodynamic efficiency and also more stable combustion than the 1750rpm points (see Figure 5.26a and Figure 5.29a).

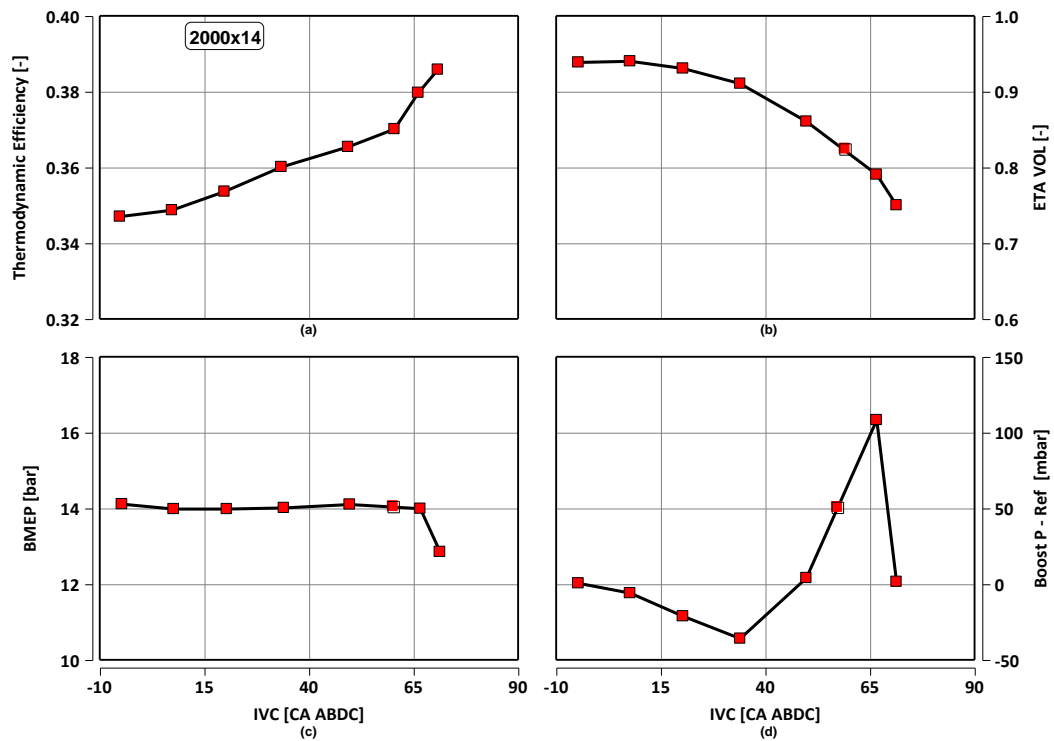

Figure 5.18. LIVC effect on thermodynamic efficiency (a), volumetric efficiency (b), BMEP (c) and boost pressure referred to the value of the maximum volumetric efficiency (d) - 2000rpm x 14bar BMEP.

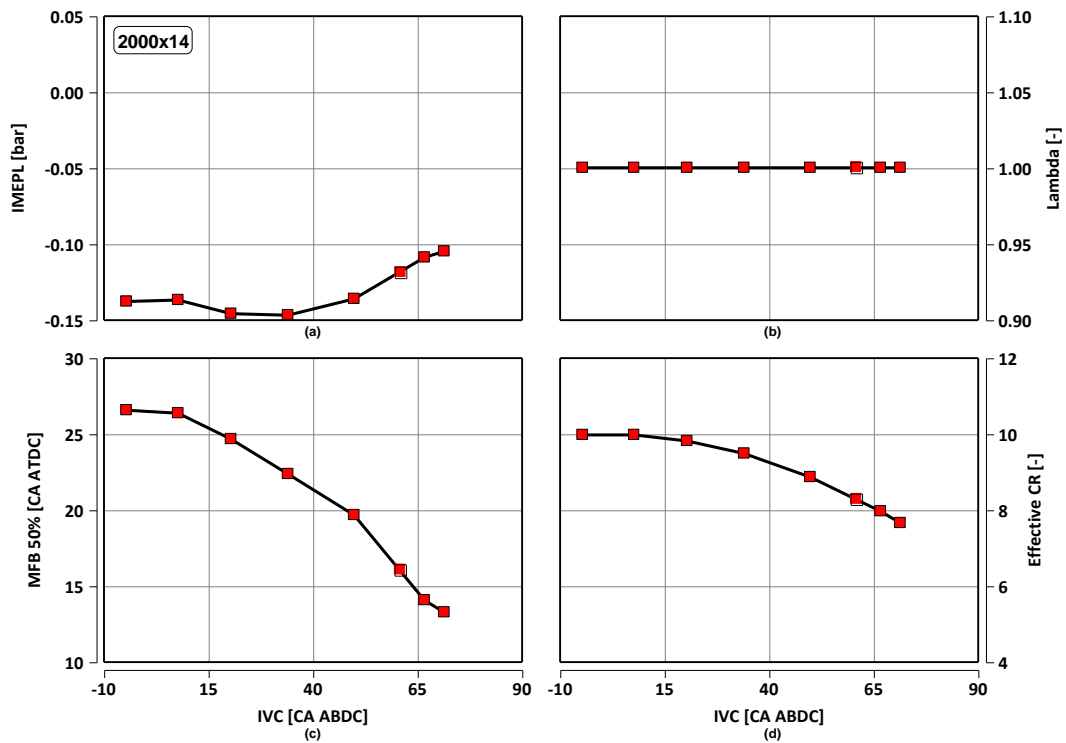

Figure 5.19. LIVC effect on IMEPL (a), Lambda (b), peak angle of the in-cylinder pressure (c) and effective compression ratio (d) - 2000rpm x 14bar BMEP.

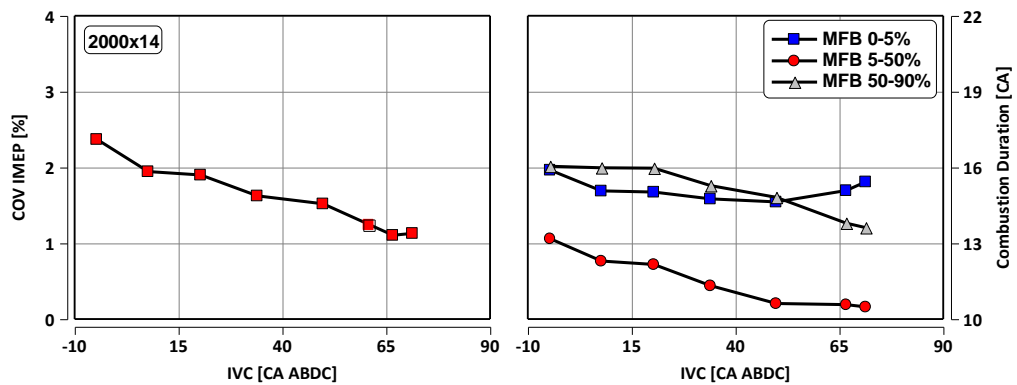

Figure 5.20. LIVC effect on COV IMEP (left), combustion durations (right) - 2000rpm x 14bar BMEP.

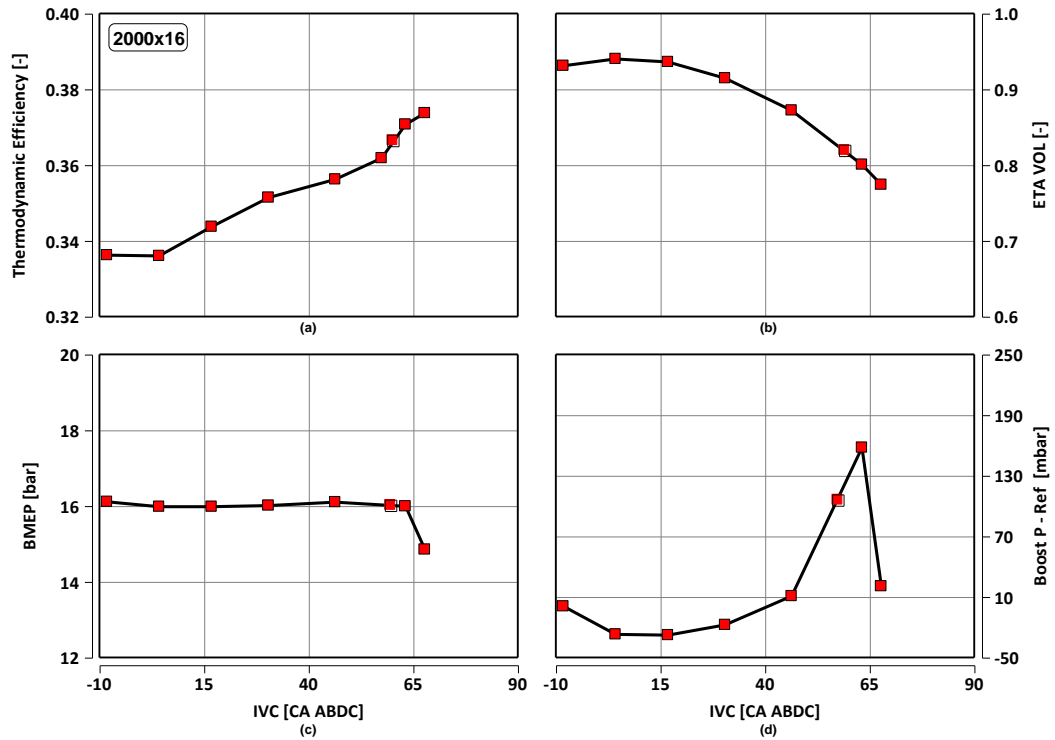

Figure 5.21. LIVC effect on thermodynamic efficiency (a), volumetric efficiency (b), BMEP (c) and boost pressure referred to the value of the maximum volumetric efficiency (d) - 2000rpm x 16bar BMEP.

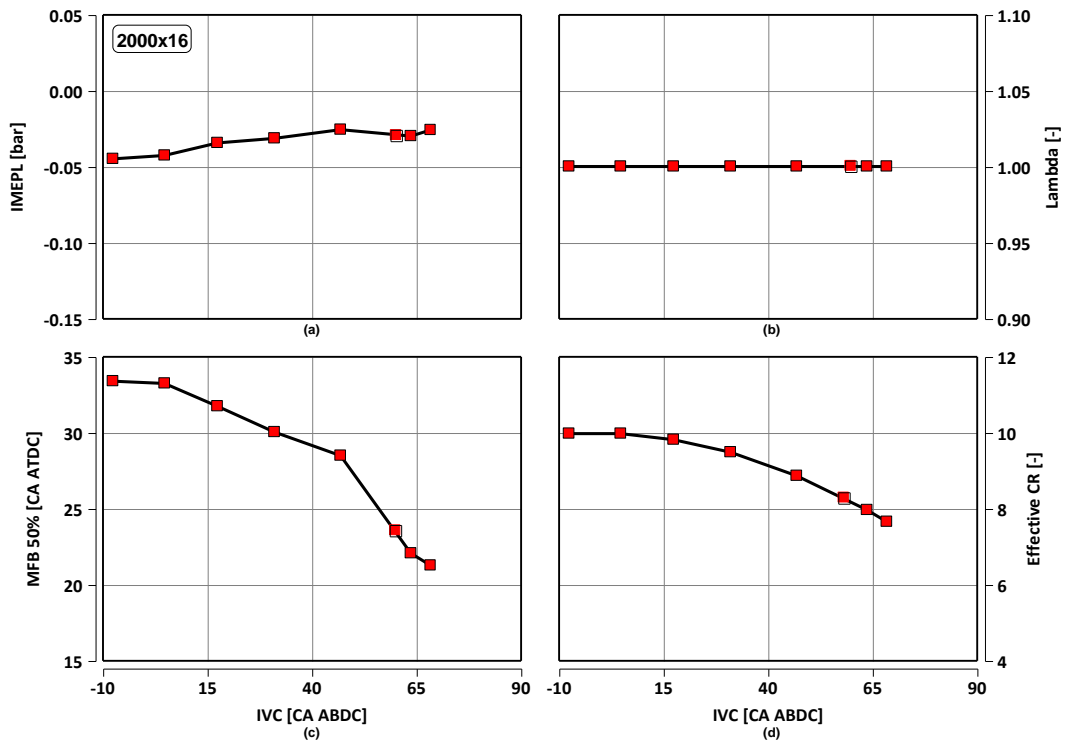

Figure 5.22. LIVC effect on IMEPL (a), Lambda (b), peak angle of the in-cylinder pressure (c) and effective compression ratio (d) - 2000rpm x 16bar BMEP.

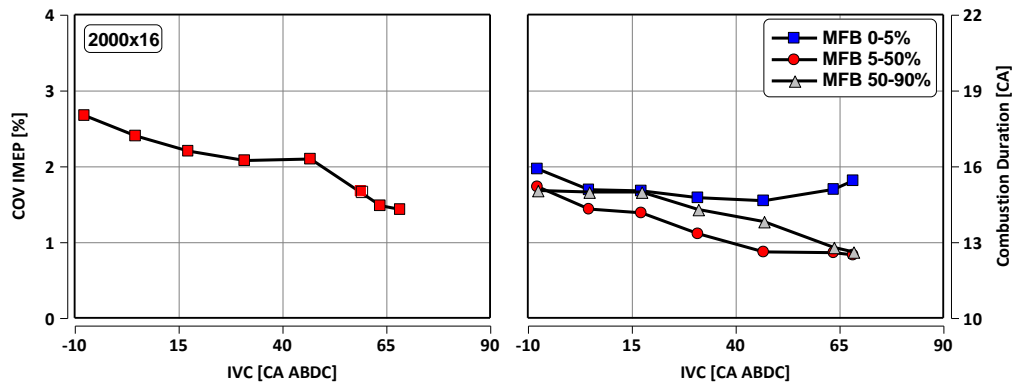

Figure 5.23. LIVC effect on COV IMEP (left), combustion durations (right) - 2000rpm x 16bar BMEP.

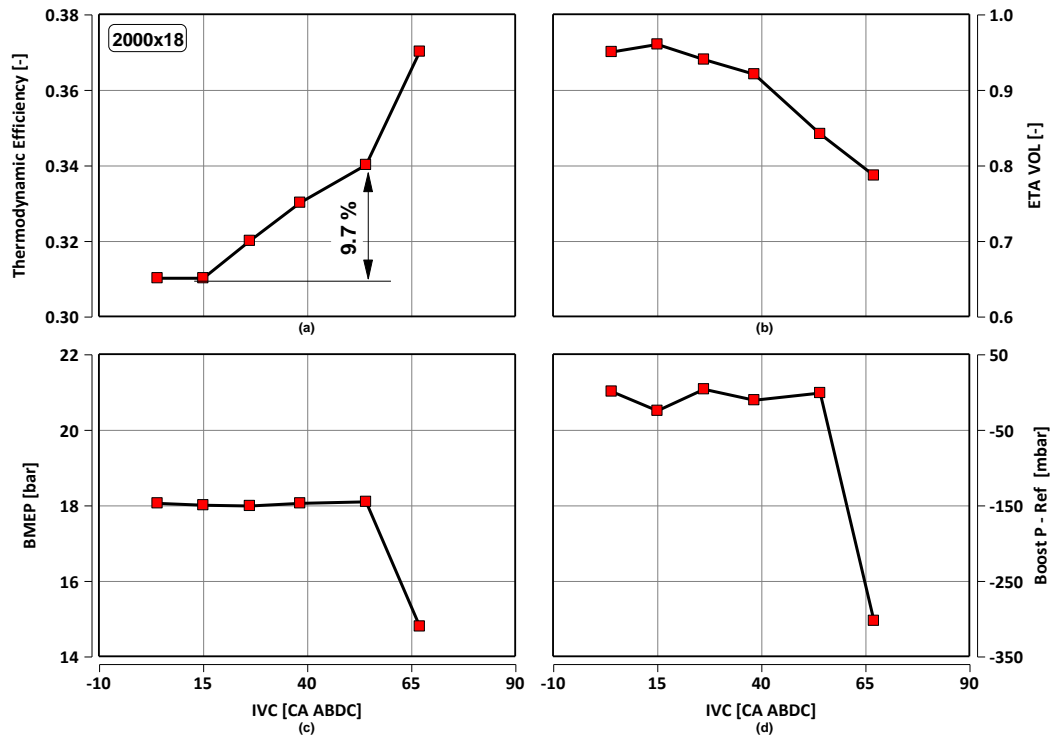

Figure 5.24. LIVC effect on thermodynamic efficiency (a), volumetric efficiency (b), BMEP (c) and boost pressure referred to the value of the maximum volumetric efficiency (d) - 2000rpm x 18bar BMEP.

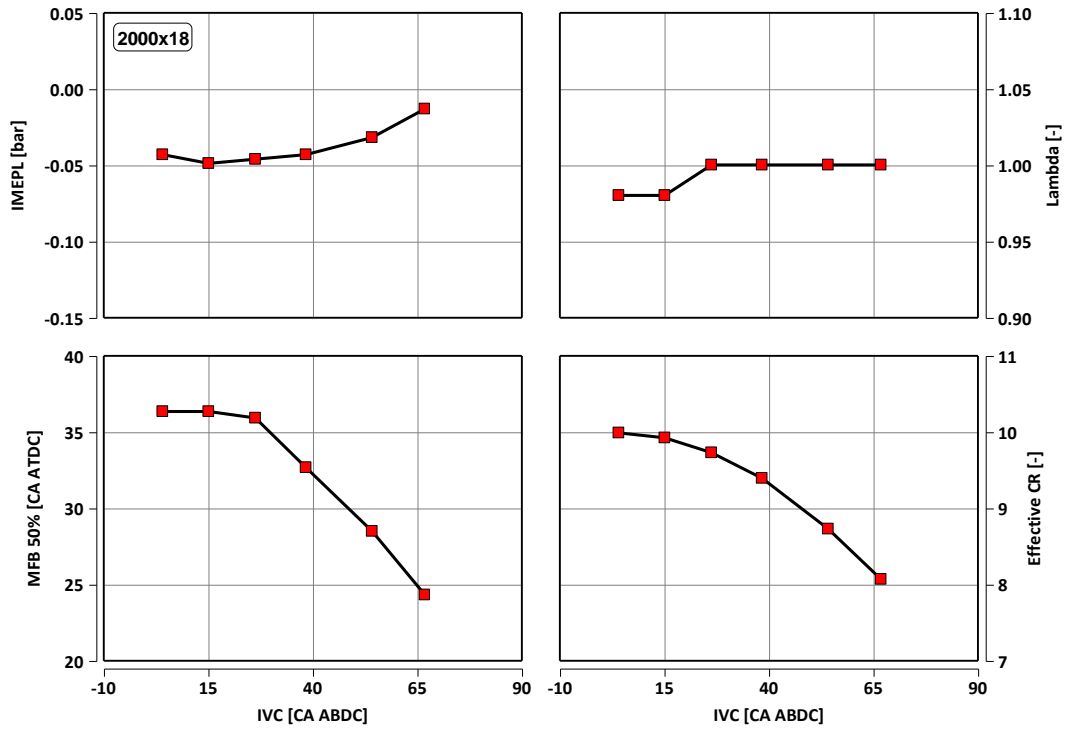

Figure 5.25. LIVC effect on IMEPL (a), Lambda (b), peak angle of the in-cylinder pressure (c) and effective compression ratio (d) - 2000rpm x 18bar BMEP.

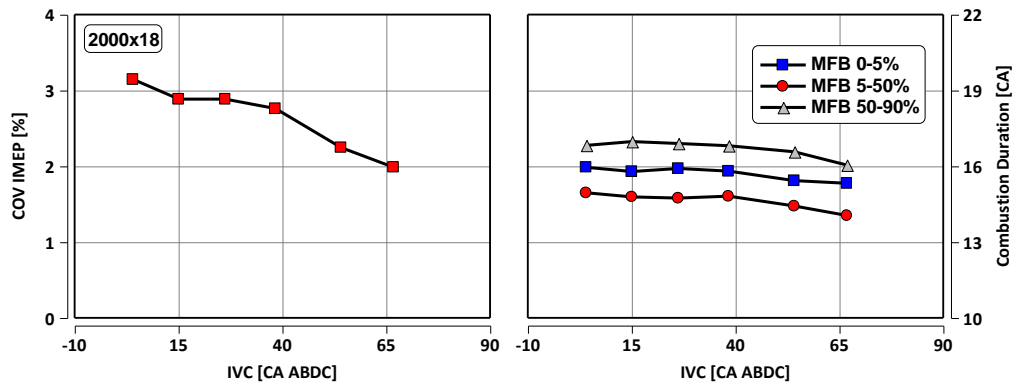

Figure 5.26. LIVC effect on COV IMEP (left), combustion durations (right) - 2000rpm x 18bar BMEP.

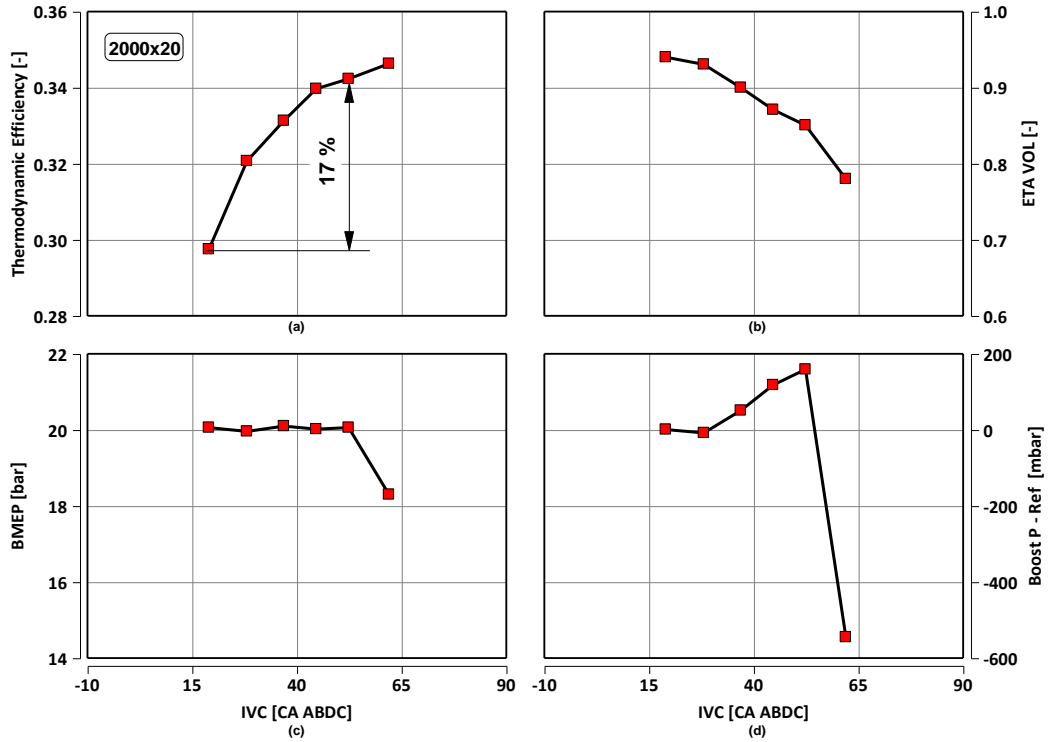

Figure 5.27. LIVC effect on thermodynamic efficiency (a), volumetric efficiency (b), BMEP (c) and boost pressure referred to the value of the maximum volumetric efficiency (d) - 2000rpm x 20bar BMEP.

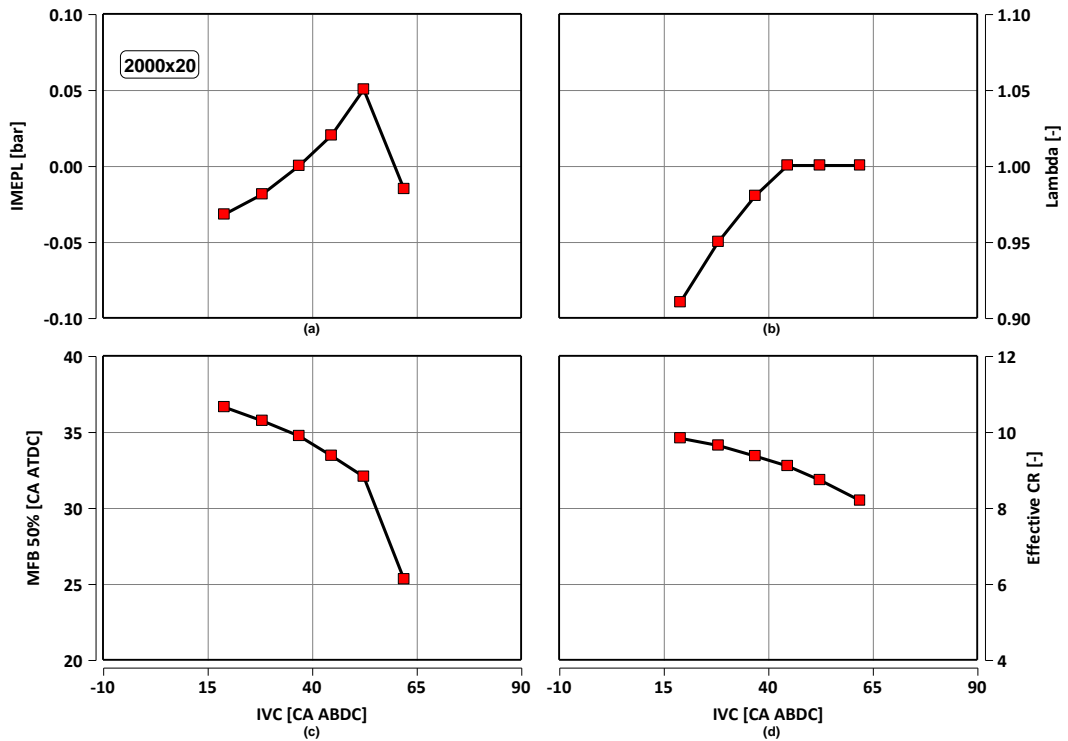

Figure 5.28. LIVC effect on IMEPL (a), Lambda (b), peak angle of the in-cylinder pressure (c) and effective compression ratio (d) - 2000rpm x 20bar BMEP.

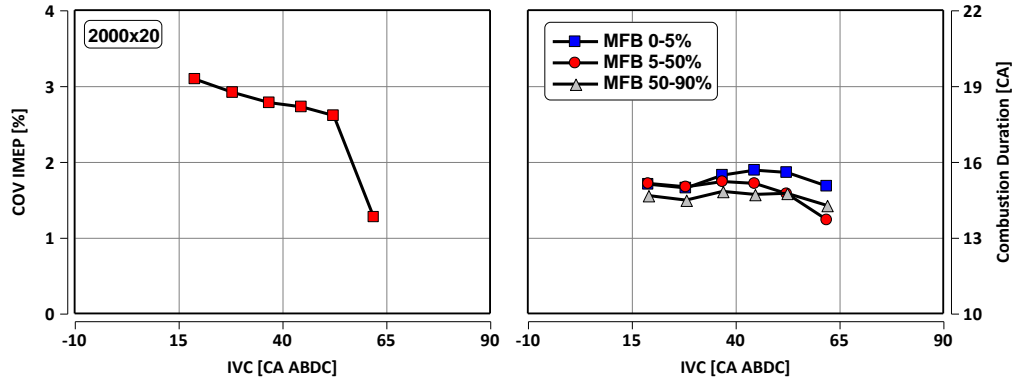

Figure 5.29. LIVC effect on COV IMEP (left), combustion durations (right) - 2000rpm x 20bar BMEP.

The Extreme late cam can be better exploited at 3000rpm thanks to the boost pressure availability. It is possible to run the engine with an extreme delayed IVC, that ranges from 104 to 90 CA ABDC along the load section (see Figures 5.30 – 5.33 – 5.36 – 5.39). At 3000x14 is possible to set a maximum IVC of 104 CA ABDC (see Figure 5.30a) reaching a 5.3% improvement in thermodynamic efficiency with respect to the maximum NP configuration. The combustion phasing is advanced of 7 CA, since the MFB 50% passes from 16 to 9 CA ATDC (see Figure 5.31c). Since the volumetric efficiency drops from 0.87 to 0.61 (see Figure 5.30b), the boost required to reach 16 bar BMEP is increased of 560 mbar (see Figure 5.30d). For this reason, along the IVC sweep the boost pressure increase is responsible for a rise in IMEPL of 0.2 bar (see Figure 5.31a).

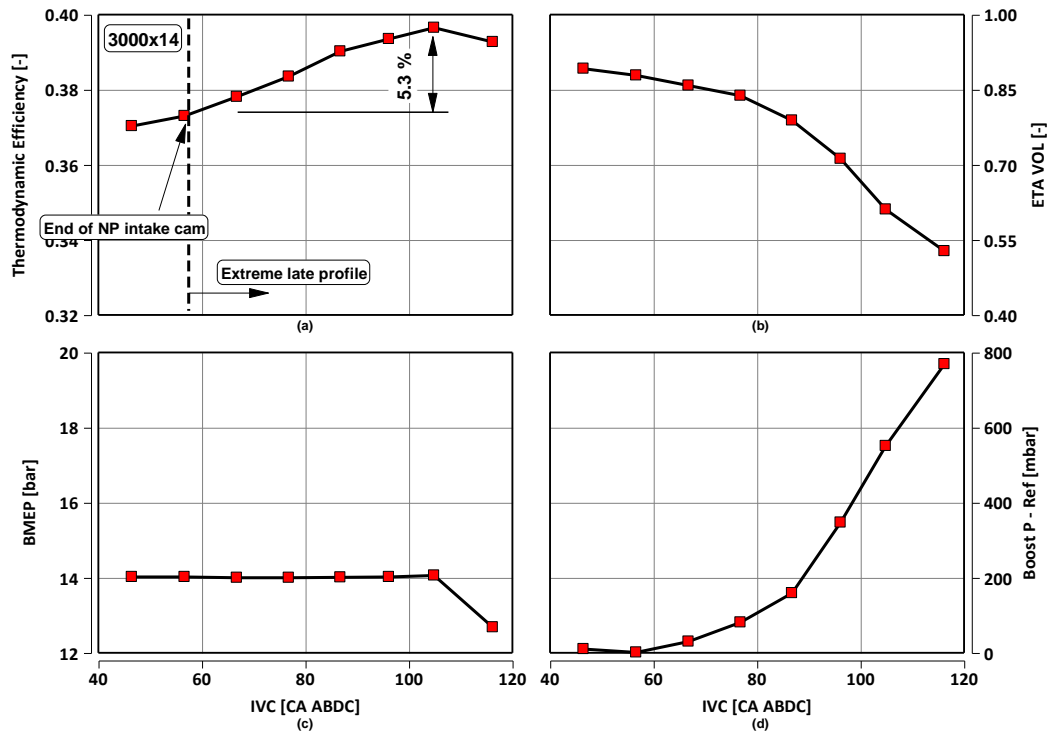

Figure 5.30. LIVC effect on thermodynamic efficiency (a), volumetric efficiency (b), BMEP (c) and boost pressure referred to the value of the maximum volumetric efficiency (d) - 3000rpm x 14bar BMEP.

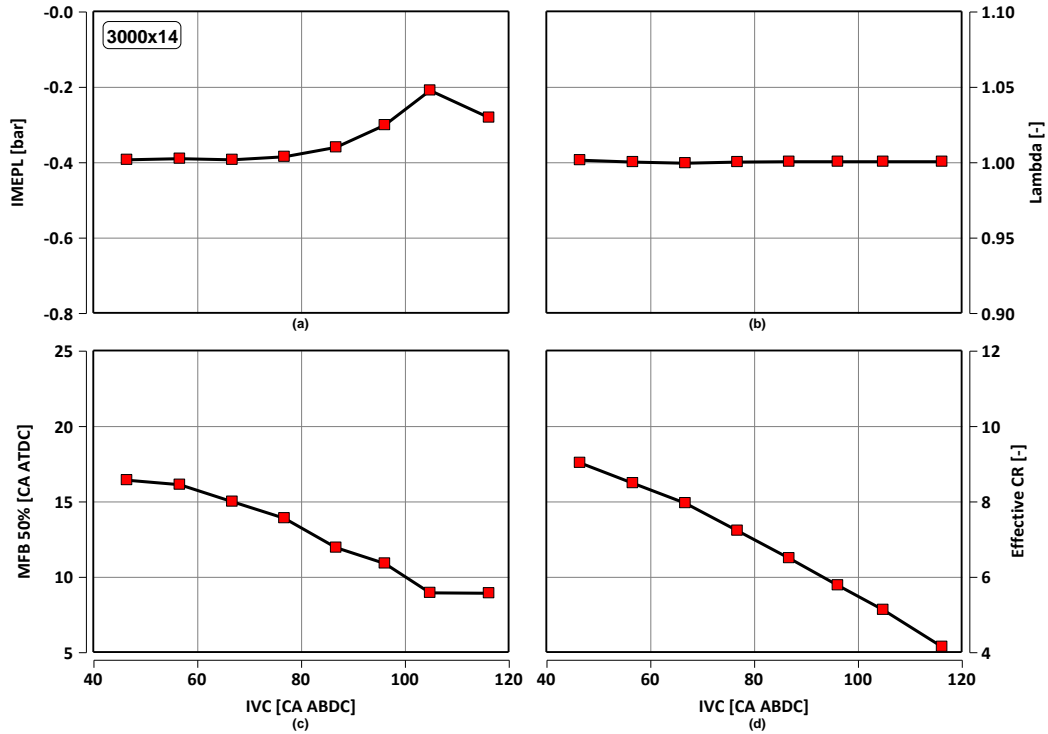

Figure 5.31. LIVC effect on IMEPL (a), Lambda (b), peak angle of the in-cylinder pressure (c) and effective compression ratio (d) - 3000rpm x 14bar BMEP.

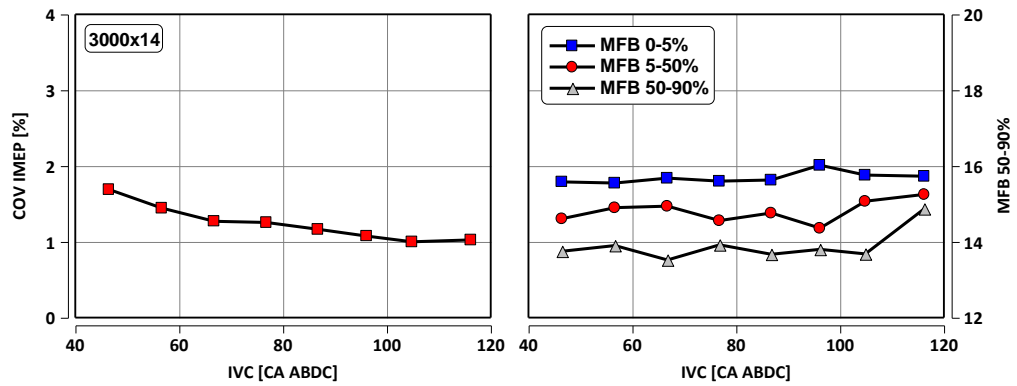

Figure 5.32. LIVC effect on COV IMEP (left), combustion durations (right) - 3000rpm x 14bar BMEP.

Differently from the load sections at 2000rpm and 1750rpm, it is possible to use the Max late cam at 18 and 20 bar BMEP with a benefit of 10.8% and 20.3% in thermodynamic efficiency (see Figure 5.36a and 5.39a). Moreover, while at 20 bar BMEP the NP actuation requires a substantial enrichment of the mixture in order to limit the inlet turbine temperature at 950 °C, the Max late cam allows the stoichiometric condition on the entire load section (see Figure 5.37b and Figure 5.40b).

Since from this analysis it can be pointed out that the optimal IVC is the maximum possible late closure, the load sections at 4000rpm and 5000rpm have been compared only in the optimal IVC and on the NP cam IVC without any sweep, and the main results are reported in the table 5.2.

From the analysis here reported, it can therefore be concluded that the LIVC strategy is effective in the high engine load region; since the selected engine operating points are representative of the real life engine cycle for a vehicle of the C segment, the LIVC actuation represents an effective strategy to further reduce the fuel consumption.

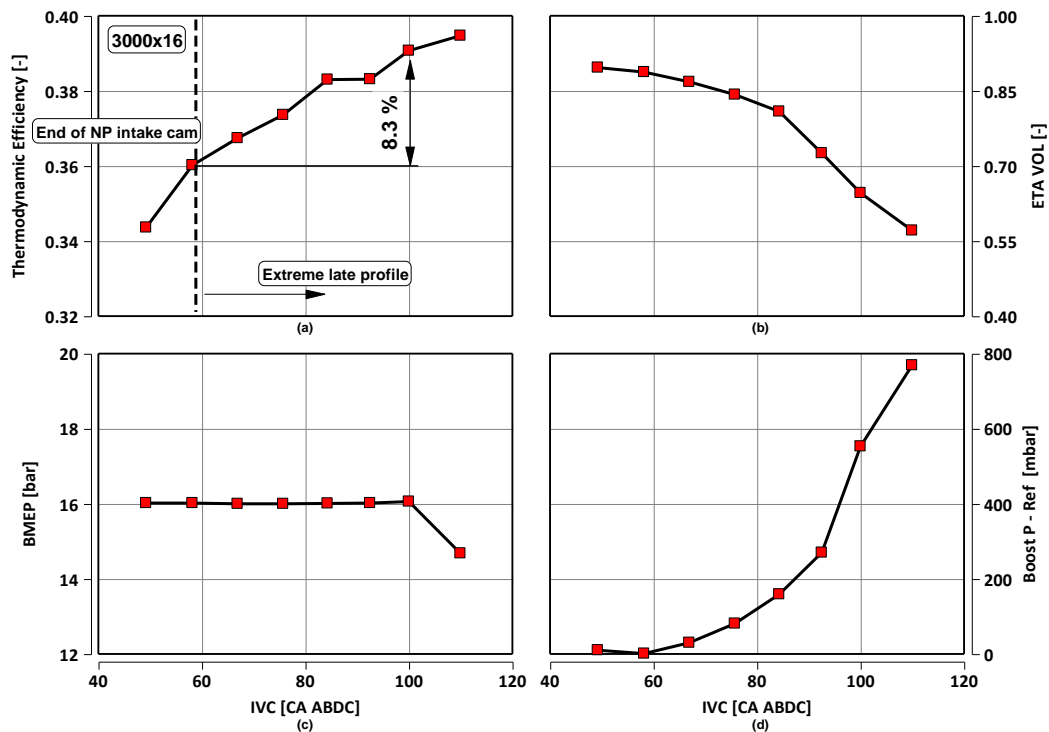

Figure 5.33. LIVC effect on thermodynamic efficiency (a), volumetric efficiency (b), BMEP (c) and boost pressure referred to the value of the maximum volumetric efficiency (d) - 3000rpm x 16bar BMEP.

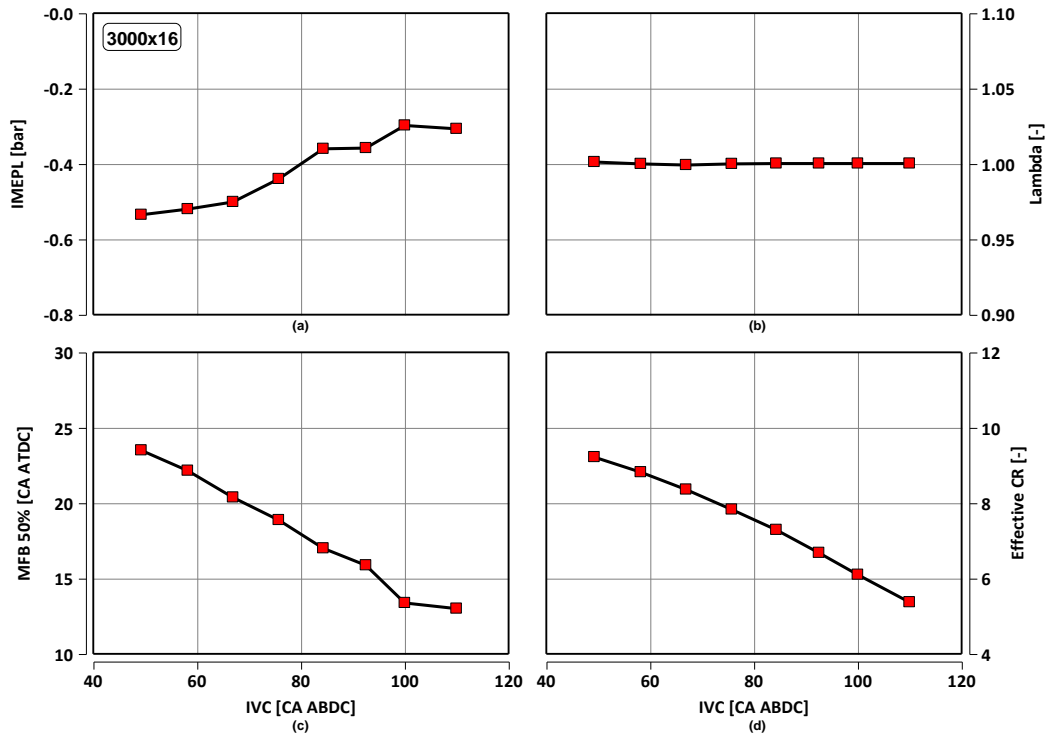

Figure 5.34. LIVC effect on IMEPL (a), Lambda (b), peak angle of the in-cylinder pressure (c) and effective compression ratio (d) - 3000rpm x 16bar BMEP.

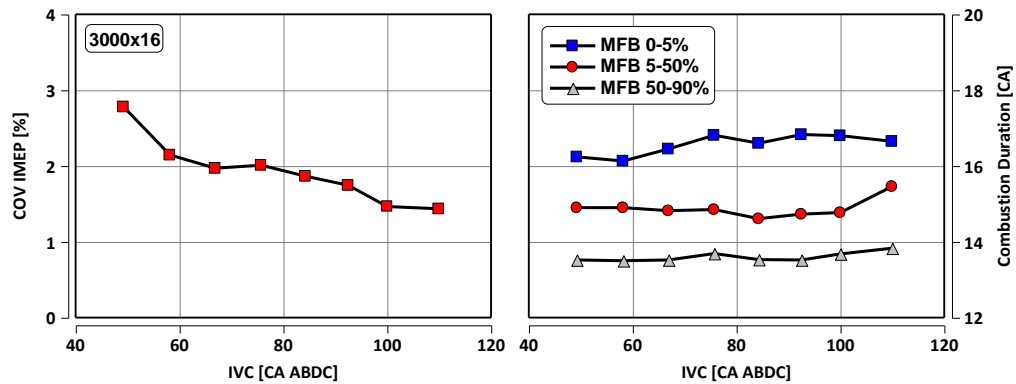

Figure 5.35. LIVC effect on COV IMEP (left), combustion durations (right) - 3000rpm x 16bar BMEP.

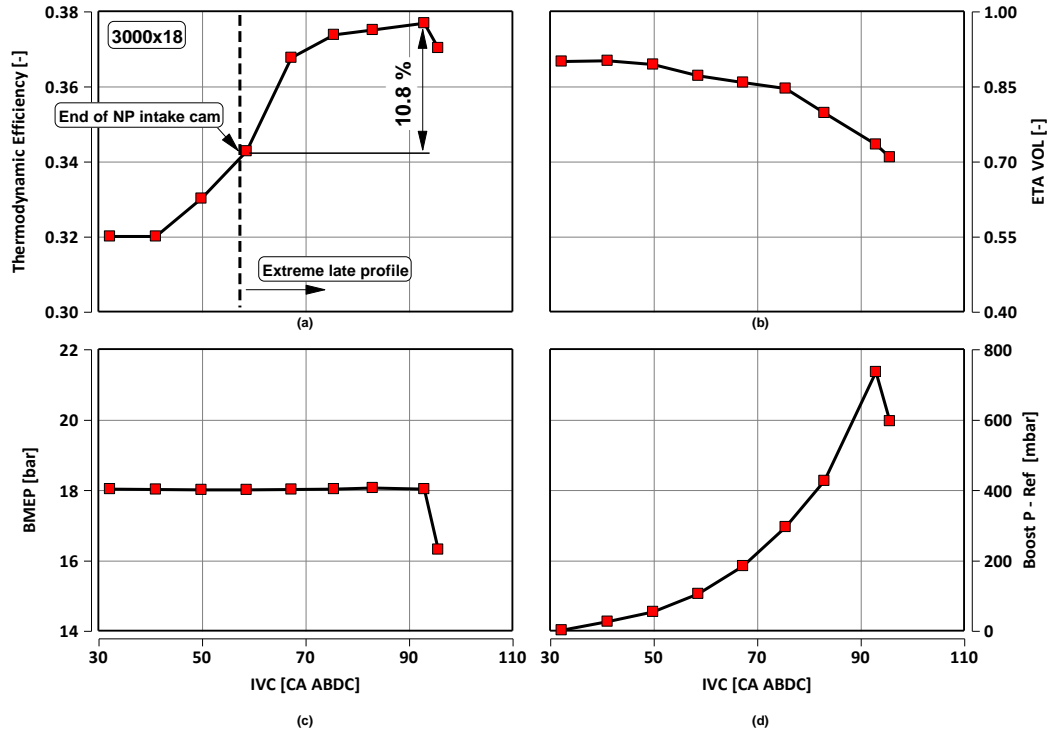

Figure 5.36. LIVC effect on thermodynamic efficiency (a), volumetric efficiency (b), BMEP (c) and boost pressure referred to the value of the maximum volumetric efficiency (d) - 3000rpm x 18bar BMEP.

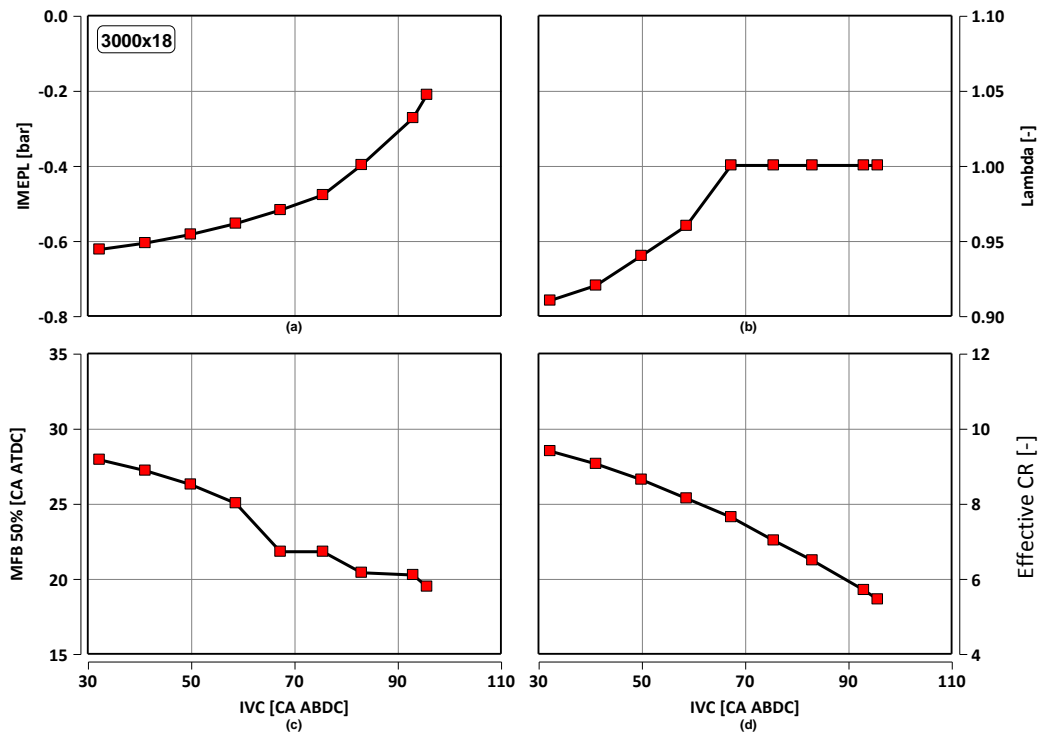

Figure 5.37. LIVC effect on IMEPL (a), Lambda (b), peak angle of the in-cylinder pressure (c) and effective compression ratio (d) - 3000rpm x 18bar BMEP.

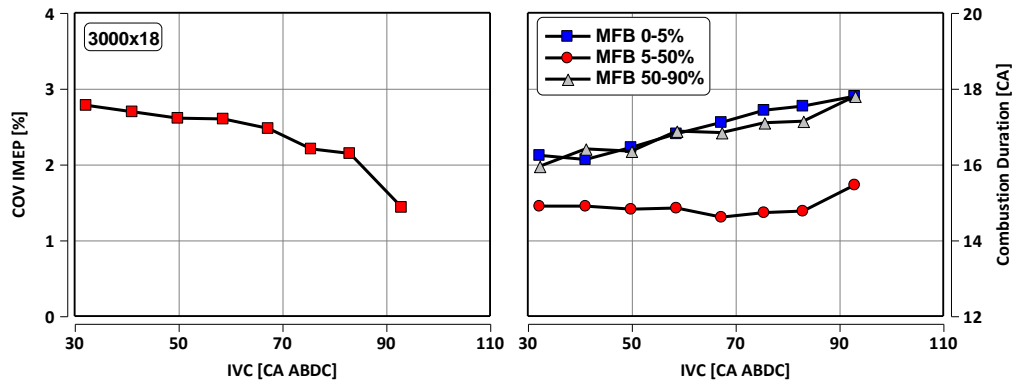

Figure 5.38. LIVC effect on COV IMEP (left), combustion durations (right) - 3000rpm x 18bar BMEP.

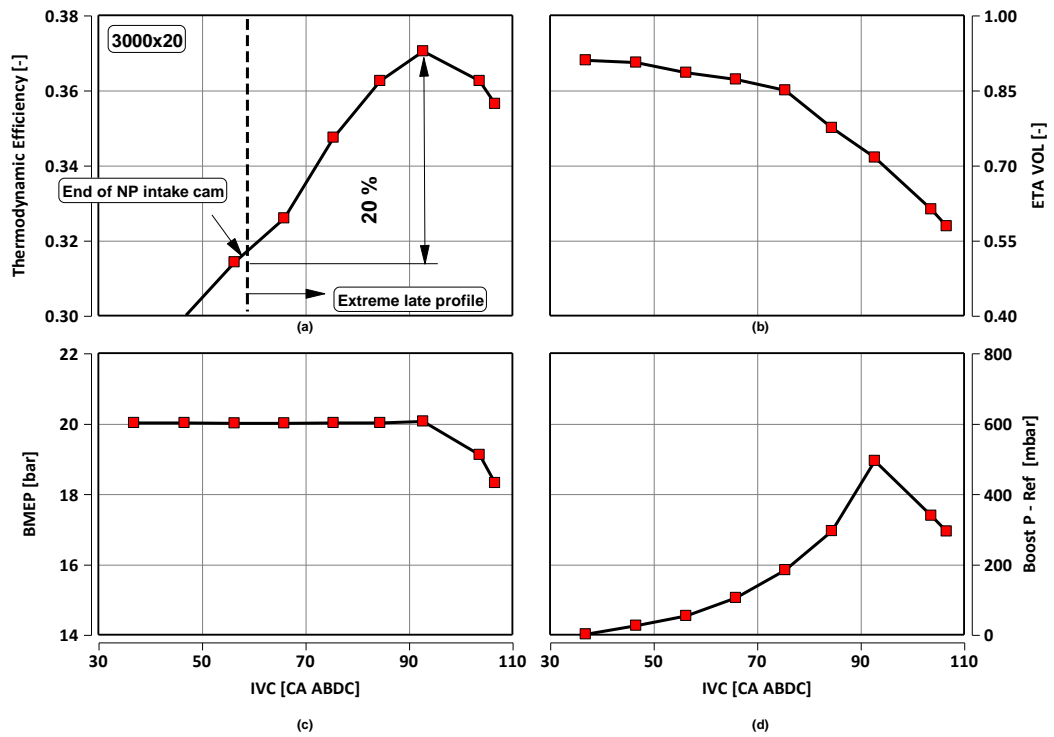

Figure 5.39. LIVC effect on thermodynamic efficiency (a), volumetric efficiency (b), BMEP (c) and boost pressure referred to the value of the maximum volumetric efficiency (d) - 3000rpm x 20bar BMEP.

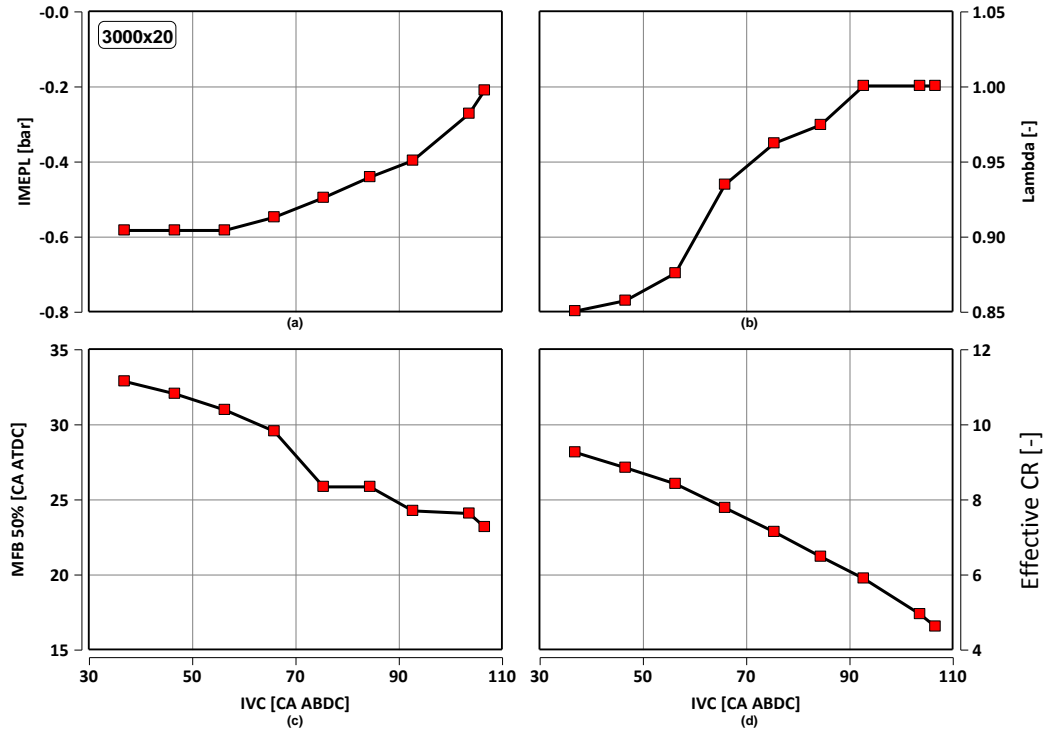

Figure 5.40. LIVC effect on IMEPL (a), Lambda (b), peak angle of the in-cylinder pressure (c) and effective compression ratio (d) - 3000rpm x 20bar BMEP.

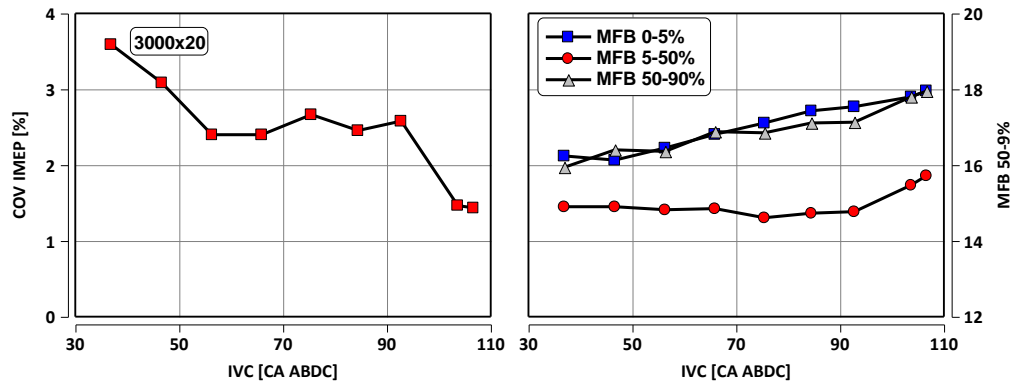

Figure 5.41. LIVC effect on COV IMEP (left), combustion durations (right) - 3000rpm x 20bar BMEP.

CONCLUSIONS

The experimental activity presented in the dissertation was focused on the fuel conversion efficiency optimization on a **VVA Multiair turbocharged gasoline engine**. At low engine load the experimental investigation involved basically the pumping losses reduction. The first step was the increase of in-cylinder turbulence through the comparison of specific cylinder head layouts, with the aim to enhance the tradeoff between the iEGR and the combustion stability. Then the engine displacement modularity was developed in order to operate the internal combustion engine in the highest efficiency zone also at low engine loads.

The effects of the late intake valve closure (LIVC) on the thermodynamic efficiency have been investigated.

Regarding the **turbulence optimization**, two different modifications of the baseline cylinder head configuration were designed and experimentally tested in order to address the issue of the poor in-cylinder turbulence levels, which are typical of the Early-Intake-Valve-Closing (EIVC) strategies which are adopted in Variable Valve Actuation systems at part load to reduce pumping losses. The first layout promotes turbulence by increasing the tumble motion at low valve lifts, while the second one allows the addition of a swirl vortex to the main tumble structure. The aim for both designs was to achieve a proper flame propagation speed at both part and full load. From the analysis carried out at part load it can be concluded that the enhanced tumble layout has the most significant and positive effect in fastening the combustion process and extending the EGR tolerance, while enhanced swirl layout shows an intermediate performance. Nevertheless, the Tumble solution (which enhanced the tumble motion at the low valve lifts used at part load, but decreased the tumble intensity under the full lift operation used at full load) could not reach the performance target, since the knock mitigation was not sufficient to compensate the loss in combustion efficiency due to the slower combustion; this solution should therefore be discarded, despite the significant benefits provided at part load. The Swirl solution did not show significant performance deteriorations, thus fulfilling the full load requirements, although providing only limited benefits at part load. In conclusion the cylinder head featuring the best trade-off between full and part load performance was identified.

The further analysis was focused on the engine **displacement modularity**; the aim of this technique is to realize a flexible downsizing in order to operate the internal combustion engine in the highest efficiency zone also at low engine loads. The effect in reducing the pumping loss is significant at the lowest load and decreases as the load increases; the break-even point in terms of load is 3 bar BMEP at 2000rpm and 2 bar BMEP at 3000rpm. Since the selected engine operating points are representative of the NEDC cycle for a vehicle of the C segment, the displacement modularity represents an effective strategy to further reduce the fuel consumption with a decrease of pumping losses that reaches the 30% in the lowest load region (1 bar BMEP).

From the analysis conducted at high load it can therefore be concluded that the **LIVC strategy** is effective in the high engine load region. The LIVC strategy begins to be effective at 2500rpm, where along the load section the benefit in thermodynamic efficiency ranges from 3.7% to 6.6%. However, the highest impact is registered at 3000x18 and 20, in which the LIVC allows to run the engine operating points under stoichiometric conditions with an increase in thermodynamic efficiency of 20%. For increasing speed the LIVC has less important effects because the knocking occurrence is partially mitigated by the increased engine speed. Finally, since the selected engine operating points are representative of the real life engine cycle for a vehicle of the C segment, the LIVC actuation represents an effective strategy to further reduce the fuel consumption.

Bibliography

- [1] Millo, F., Rolando, L., and Servetto, E., "Development of a Control Strategy for Complex Light-Duty Diesel-Hybrid Powertrains," SAE Technical Paper 2011-24-0076, 2011, doi:10.4271/2011-24-0076.
- [2] Millo F., Rolando L., and Mallamo F., "Development of an optimal strategy for the energy management of a range extended electric vehicle," *Proceedings of the Institution of Mechanical Engineers, Part D: Journal of Automobile Engineering January 2013 vol. 227 no. 1 4-16*
- [3] Vehicle Fuel Economy and Greenhouse Gas Emissions Standards. <http://www.afdc.energy.gov/laws/law/US/385>.
- [4]. EPA and CARB Emission Standards To Control Nonroad Exhaust Emissions of Fire Pumps and Chain Saws
<http://www.fs.fed.us/t-d/pubs/html/02511204/02511204.htm>
- [5] Canada's Passenger Automobile and Light Truck Greenhouse Gas Emission Regulations for Model Years 2011-2016.
- [6] Alkidas 2007, Combustion advancements in gasoline engines, *Energy Conversion and Management* 48 (2007) 2751-2761.
- [7] Lake et al. 2003, Turbocharging Concepts for Downsized DI Gasoline Engines, *SAE Transaction* 2004, vol. 113, no 3 (2042 p.)
- [8]http://www.bmw.com/com/en/insights/technology/technology_guide/articles/mm_valvetronic.html. BMW's Valvetronic.
- [9] Honda's VTEC <http://world.honda.com/news/2006/4060925VTEC/>.
- [10] EC2002, Variable Compression Ratio Technology for CO2 Reduction of Gasoline Engines in Passenger Cars, European Commission Community Research. http://ec.europa.eu/research/conferences/2002/pdf/presspacks/1-1-vcr_en.pdf.
- [11]. EPA 2008, EPA Staff Technical Report: Cost and Effectiveness Estimates of Technologies Used to Reduce Light-duty Vehicle Carbon Dioxide Emissions, EPA420-R-08-008, United States Environment Protection Agency, March 2008.

- [12]. EPA 2008, A Study of Potential Effectiveness of Carbon Dioxide Reducing Vehicle Technologies, Revised Final Report, EPA420- R-08-004a, United States Environment Protection Agency, June 2008.
- [13]. IEA 2005, Making cars more efficient: Technology for Real Improvements on the Road, International Energy Agency and European Conference of Ministers of Transport Joint Report, 2005.
- [14]. TNO 2006, Review and analysis of the reduction potential and costs of technological and other measures to reduce CO₂-emissions from passenger cars, Contract nr. S12.408212, TNO/ IEEP/ LAT, October 2006.
- [15]. Drake and Haworth 2007, Advanced gasoline engine development using optical diagnostics and numerical modelling, Proceedings of the Combustion Institute 31 (2007) 99-124.
- [16] Mittal V., Revier B., Heywood J.B., 2007, "Phenomena that Determine Knock Onset in Spark-Ignition Engines", SAE Technical Paper 2007-01-0007.
- [17] Eckert P., Song-Charng Kong S., Reitz R., 2003, "Modeling Autoignition and Engine Knock", SAE Technical Paper 2003-01-0011.
- [18] Carbon Trust 2003, Low Cost Solution for Gasoline Engine Controlled Auto Ignition, Project reference number 2003-5-22.
- [19] The Williams Helical Camshaft: '<http://www.helicalcamshaft.com/>'
- [20] Schwarz, C., Schneider, j., and Koch, K. F.: "The Valvetronic Experience from Seven Years of Mass Production and a Discussion of Future Prospects", MTZ, 07-08/2008, Volume 69, 2008.
- [21]. Bernard, L., Ferrari, A., Micelli, D., Perotto, A., Rinolfi, R. and Vattaneo, F.: "Electro-hydraulic Valve Control with MultiAir Technology", MTZ Press 12I2009, Volume 70, 2009.
- [22] Millo, F., Luisi, S., Stroppiana, A., and Borean, F., "Numerical and experimental investigation on combustion characteristics of a spark ignition engine with an early intake valve closing load control" Fuel, Volume 121, 1 April 2014, Pages 298–310
- [23] Millo, F., Luisi, S., Stroppiana, A., and Borean, F., "Effects of Different Geometries of the Cylinder Head on the Combustion Characteristics of a VVA Gasoline Engine," SAE Technical Paper 2013-24-0057, 2013, doi:10.4271/2013-24-0057.
- [24] Cope D., Wright A., "Electromagnetic Fully Flexible Valve Actuator", SAE Technical Paper, 2006-01-0044.

[25] STURMAN Hydraulic Valve Actuation “HVA”, presented to CARB Symposium April 20th 2004.

[26] Trajkovic S., Milosavljevic A., Tunestål P. and Johansson B., “FPGA Controlled Pneumatic Variable Valve Actuation”, SAE International 2006-01-0041.

[27] Borean, F., Lucatello, M., “Internal combustion engine with cylinders that can be deactivated, with exhaust gas recirculation by variable control of the intake valves, and method for controlling an internal combustion engine”, EP2397674A1.