

Up to 4 × 192 LTE-A radio waveforms transmission in a point to multipoint architecture for massive fronthauling solutions

Original

Up to 4 × 192 LTE-A radio waveforms transmission in a point to multipoint architecture for massive fronthauling solutions / Torres Ferrera, P.; Straullu, S.; Abrate, S.; Vinci, A.; Gaudino, R.. - ELETTRONICO. - (2017). (Intervento presentato al convegno 19th Italian National Conference on Photonic Technologies tenutosi a Padua, Italy nel 3-5 May 2017) [10.1049/cp.2017.0186].

Availability:

This version is available at: 11583/2896824 since: 2021-04-24T17:49:26Z

Publisher:

IET

Published

DOI:10.1049/cp.2017.0186

Terms of use:

This article is made available under terms and conditions as specified in the corresponding bibliographic description in the repository

Publisher copyright

IET postprint/Author's Accepted Manuscript (con refereeing)

(Article begins on next page)

Up to 4 x 192 LTE-A Radio Waveforms Transmission in a Point to Multipoint architecture for Massive Fronthauling Solutions

P. Torres-Ferrera¹, S. Straullu², S. Abrate², A. Vinci³, R. Gaudino^{4}*

1 Institute of Engineering, Universidad Nacional Autónoma de México, UNAM, 04510 Mexico City - Mexico

2 ISMB, Istituto Superiore Mario Boella, Via P.C. Boggio 61, 10138 Torino (TO), Italy

3 Tektronix, Via Tommaseo 74B, 35131 Padova (PD), Italy

4 Politecnico di Torino, C.so Duca degli Abruzzi 24, 10129 Torino (TO), Italy

**roberto.gaudino@polito.it*

Keywords: optical fronthauling, multi-output EDFA, fixed-mobile convergence, 5G networks.

Abstract

In this work, a novel point-to-multipoint fronthauling architecture based on the use of a Multi-Output Erbium Doped Fibre Amplifier (MO-EDFA), to deliver several digital signal processing (DSP) aggregated analogue radio waveforms, is proposed and experimentally analysed. The transmission of 4x192 20 MHz radio waveforms, according to the DSP-aggregated fronthauling (DSP-AF) Frequency Division Multiplexed (FDM) architecture originally proposed in [1]. Using the MO-EDFA, we are able to feed up to 24 remote radio head (RRH) units, experimentally demonstrating successful transmission over a link with up to 25 dB of optical path losses, including 37 km of single mode fibre.

1. Introduction

The use of optical fronthauling (i.e. the “native” transport of radio mobile signal in the access networks from central offices to the antennas site) is today already deployed for some LTE installations, and is given for granted as a key enabler for future 5G networks. The current fronthauling technology, based on the so-called Digitized Radio-over-Fiber (DRoF using either the CPRI or OBSAI de-facto standards) is suitable for today mobile network requirements, but it does not scale well for future LTE-Advanced and even more 5G networks since the bit rate to be transported may become exceedingly high. For instance, a 20 MHz LTE signal carried using CPRI requires about 1.2 Gbps. Future 5G networks may require to transport several tens of these signals per antenna site (called Remote Radio Head or RRH in the fronthauling jargon), for total bit rates that may easily go into the 100 Gb/s per RRH range. Alternative solutions for fronthauling have thus been proposed, and this paper further investigates on the DSP-AF Frequency Division Multiplexed [1]. In a nutshell, the key feature of DSP-AF is the transmission of many LTE-A (and in future 5G) waveforms using an analogue radio-over-fibre approach, but taking advantage of a specific DSP-based de/aggregation at the transmitter and receiver that, thanks to the well-known FFT and IFFT efficiency, allows to obtain frequency down-

and up-conversion and FDM aggregation with low latency and relatively low complexity using only DSP functionalities. In our previous work [2] we focused on optimizing the performance of DSP-AF in a point-to-point implementation, demonstrating the simultaneous transport of 96 20 MHz LTE radio waveforms on each of four WDM wavelengths that is suitable to be delivered in a Passive Optical Network (PON) architecture. In this paper, we propose a novel network architecture to deliver a massive version of DSP-AF to reach several different RRHs, each requiring a very high number of radio waveforms. The general architecture is shown in Fig. 1 and it targets point-to-multipoint distribution (i.e. from one central office to many RRHs) thanks to the introduction in the Central Office of the MO-EDFA. These devices are optical amplifiers developed for Video-overlay applications in PON networks, and they are characterized by one input and many outputs (24 in our experiment, each delivering approximately 17 dBm). Our focus is to demonstrate that MO-EDFAs can be used also for amplifying DSP-AF signals. We then aim at demonstrating the transport of 192 20 MHz LTE radio waveforms on each of the up to four wavelengths that we are employing in our experiments. A multi-wavelength version of the point to multipoint DSP-AF proposed architecture is shown in Fig. 2.

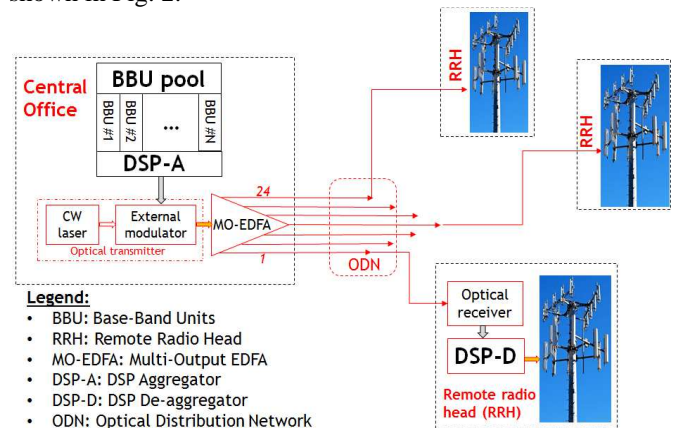

Fig. 1. Proposed DSP-AF fronthauling architecture using Multi-Output EDFA for point to multipoint distribution

2. Experimental setup

The experimental setup is shown in Fig. 3, where the downstream direction of a fronthauling architecture is

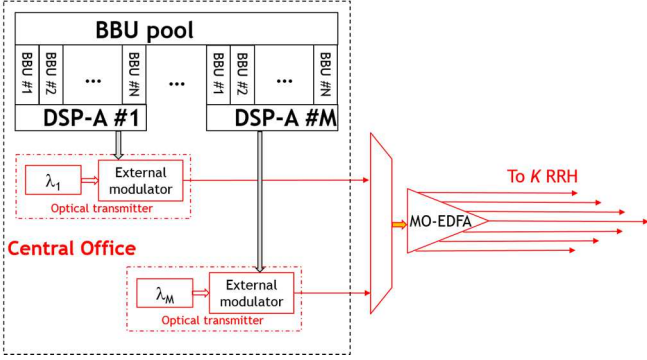

Fig. 2 Multi-wavelength version of the proposed for point to multipoint DSP-AF fronthauling architecture.

emulated. At the transmitter side (assumed to be at the central office), the same Mach-Zehnder Modulator (MZM) is used for single wavelength and multi-wavelength experiments. The MZM is driven by a DSP-aggregated $x_{FDM}(t)$ signal, which is generated in Matlab[®] and stored in a 50 GSps Tektronix Arbitrary Waveform Generator (AWG). We generated 192 LTE-A like radio waveforms by aggregating them using the FDM-based DSP approach proposed in [1] to conform the $x_{FDM}(t)$ signal. Each radio waveform is an OFDM signal using 64-QAM as digital modulation format and generated at 30.72 MHz sampling rate, emulating a 20 MHz LTE-A signal. The resulting spectral separation between adjacent radio waveforms is exactly set at 30.72 MHz, so that the total electrical spectrum is approximately equal to 6 GHz. This choice allows a very straightforward DSP aggregation procedure. The optical signal at the output of the modulator is sent to the MO-EDFA, which distributes it over its 24 output ports with minimal power difference between them (we measured less than 1 dB among the best and worst outputs). One of the MO-EDFA output signals is launched into the optical fibre plant under test. The optical path is composed by 37 km of single mode fibre (dark fiber installed in a metropolitan testbed running in the city of Turin in the same ducts carrying operators fibres) and a variable optical attenuator (VOA) for spanning different values of optical path loss (OPL). At the receiver side (that is assumed to be at one of the RRHs), an optical filter selects the desired optical channel if the WDM configuration is used. Then, an avalanche photodiode (APD) directly detects the signal, and is

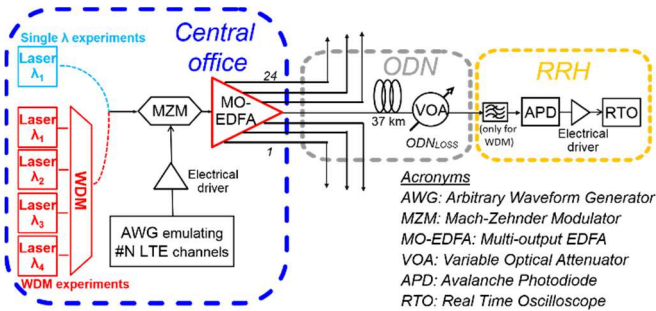

Fig. 3. Experimental Setup of the analysed DSP-AF point to multipoint system.

followed by a transimpedance amplifier and a real-time oscilloscope (RTO). The error vector magnitude (EVM) calculation is made by applying the de-aggregating post-processing algorithm implemented in Matlab[®] on the signals stored by the RTO and then demodulating each of the 192 OFDM signals. The EVM per channel is obtained as an average over all the OFDM subcarriers. The EVM values plotted in Figures 4, 5 and 8, are obtained as the maximum value of the whole set of 192 DSP-aggregated channels, after they have been equalized using the procedure described in [3] in order to obtain almost equal values on all channels.

As mentioned in the Introduction, the novelty of this work consists in an experimental evaluation of the performance of the fronthauling point to multipoint system using the MO-EDFA in different system configurations.

3. Results

At first, a single-wavelength transmission over the experimental setup depicted in Fig. 3 is considered. For OPL values of 15, 21 and 25 dB, the EVM is evaluated and plotted in Fig. 4 (red circles). For the sake of comparison, the EVM curve obtained with a single-output conventional EDFA is also reported (blue stars) in Fig. 4, in the same system working conditions. A negligible penalty when using the MO-EDFA as compared to a standard EDFA is obtained; this means that MO-EDFA's non-linear effects for single wavelength operation (as typically used in CATV applications) are small. EVM values lower than 8% are obtained for up to 25.8 dB of OPL in both single-output and multi-output cases.

The WDM transmission of two optical carriers is then analysed. From our previous results [2], no penalty due to cross-talk in the WDM case is expected. This is confirmed from the results shown in Fig. 5, in which the EVM as a function of the WDM channel spacing Δf for the 2-wavelengths case is plotted (blue stars) for an OPL = 21 dB. A negligible EVM variation as a function of Δf is observed. Moreover, an EVM around 5.6% is obtained for this case, very close to the EVM around 5.5% obtained for the single-wavelength case at the same OPL value (see Fig. 4). We can thus conclude that the MO-EDFA does not introduce

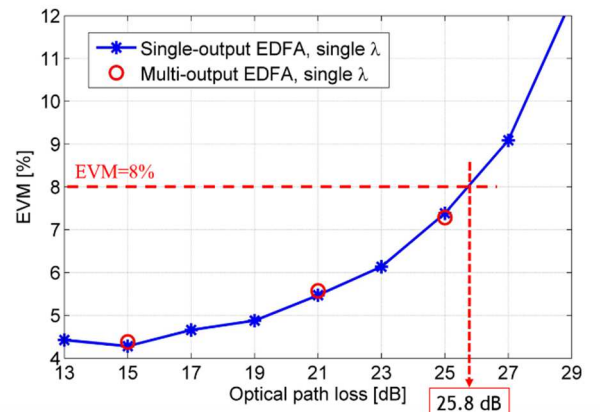

Fig. 4. EVM as a function of OPL for single-wavelength transmission using a single-output or a multi-output EDFA.

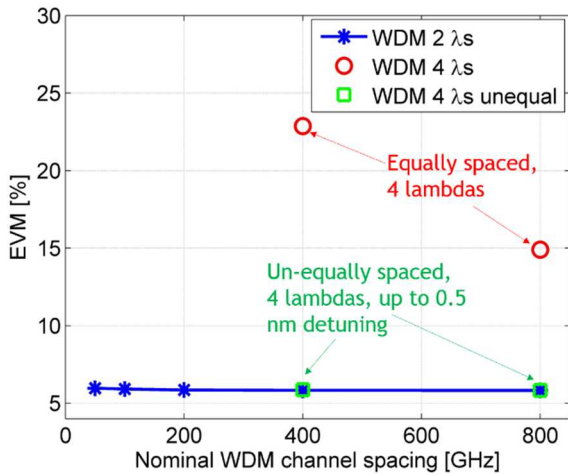

Fig. 5. EVM as a function of the nominal WDM channel spacing for different WDM transmission scenarios. An OPL of 21 dB is considered.

significant nonlinear penalties for the two-wavelength case. The results are different for the WDM transmission of four equally spaced wavelengths, as plotted in Fig. 5 (red circles), as demonstrated by the very high EVM values corresponding to $\Delta f = 400$ and 800 GHz. The high EVM value obtained for $\Delta f = 400$ GHz, for instance, corresponds to the maximum value of the EVM per channel curve (solid blue line) shown in Fig. 6 for an OPL of 21 dB. Two sets of channels (centred around channels 45 and 160, respectively) are clearly affected from a frequency-selective impairment which drastically deteriorates their performance. From Fig. 5 it could be noticed that the worst EVM value decreases as increasing Δf from 400 to 800 GHz, as expected. Since linear cross-talk was discarded to play a role on the system performance, as shown in the two previous two-wavelength case, and a Δf -dependent phenomenon is causing this frequency-selective deleterious effect, we attribute this behaviour to the four wave mixing (FWM) effect generated inside the MO-EDFA. This is

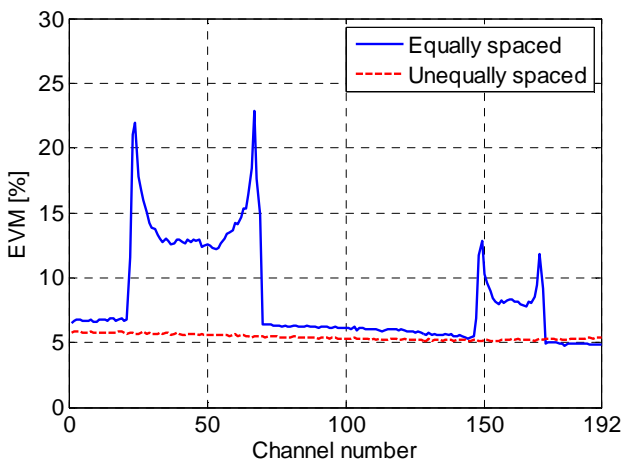

Fig. 6. EVM per aggregated channel for the WDM transmission of four equally or unequally spaced wavelengths. An OPL of 21 dB and a nominal WDM channel spacing of 400 GHz are set.

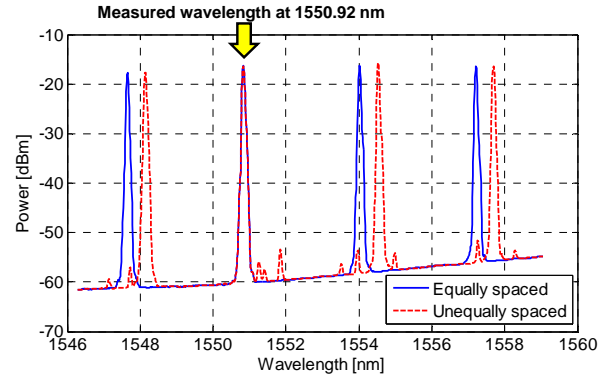

Fig. 7. Optical spectra of the WDM four-wavelengths equally and unequally spaced signals. An OPL of 21 dB and a nominal WDM channel spacing of 400 GHz are set.

actually quite understandable, considering that, internally, the MO-EDFA amplifies the input optical signal to very high power levels (of the order of several hundreds of mW) before splitting it to the 24 output fibers. In fact, MO-EDFA are conventionally used in single wavelength CATV systems, thus avoiding any non-linear behaviour. Anyway, a well-known alternative to diminish the impact of FWM when the number of used wavelength is limited, as in our case, is a frequency-shifting of the optical channels to obtain an unequal channel-spacing among them [4]. In Fig. 7, the spectra of the WDM channels are shown for equally (solid blue line, with $\Delta f = 400$ GHz) and unequally (dashed red line, with centre frequencies at 1548.211, 1550.918, 1554.625 and 1557.832 nm) spaced frequency grids. The FWM tones generated at the output of the MO-EDFA are evident in the unequally spaced grid spectrum, but they all fall outside the spectrum of the useful signals. On the contrary, these tones are not visible in the equally spaced grid since they fall in-band, thus affecting the channels in which they are present, as can be observed in Fig. 6.

The dashed red curve shown in Fig. 6 plots the resulting EVM per channel obtained by setting the referred unequally spaced channel grid on the WDM four-wavelength transmission scenario. The frequency selective EVM jumps are no longer present in this case. Instead, a flat EVM per channel distribution is observed. Then, a maximum EVM around

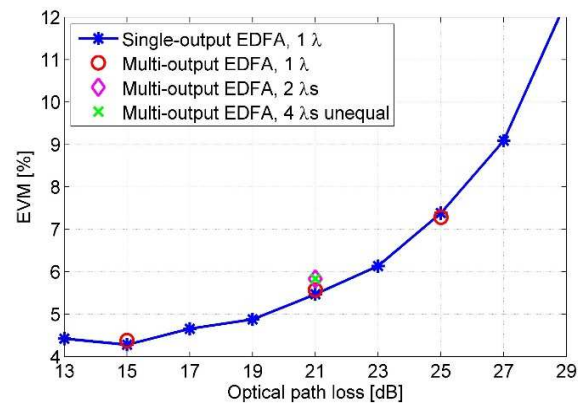

Fig. 8. EVM as a function of OPL for different transmission scenarios.

5.9% is obtained. As plotted in the green squares of Fig. 5, a similar EVM is obtained for the $\Delta f = 800$ GHz case when an unequally spaced grid is set. These pair of results thus confirm that the effect of FWM is responsible for the EVM degradation observed in Fig. 5 and Fig. 6 for the equally spaced grid case.

To summarize this section, in Fig. 8 we plot the EVM as a function of the OPL for some of the previously analysed cases. By comparing the diamond-pink points with the cross-green points, corresponding to the WDM transmission of two equally spaced and four unequally spaced wavelengths using the MO-EDFA, respectively, a negligible performance difference between them could be observed. By comparing this two points with the corresponding red (circle) point for an OPL = 21 dB, a slight EVM difference between the single-wavelength and the WDM transmission is obtained. However, a 6% EVM is still achieved for a 4 x 192 channels transmission, for an OPL up to 21 dB. Extrapolating the trend of the single-wavelength single-output and multi-output EDFA curves, an EVM = 8% for an OPL up to 25 dB could be predicted for the four-wavelength transmission. The total bit rate that would be required using CPRI for the transmission of the same 4x192 20 MHz radio channels would be around 768 Gb/s.

4. Conclusions

In this work we propose a new architecture to deliver massive DSP-aggregated FDMA fronthauling taking advantage of MO-EDFA. We have shown that for single-wavelength operation, there is no penalty in moving from single-output to multiple-output EDFA. However, for WDM operation, nonlinear effects in MO-EDFA requires unequal WDM channel spacing for the transmission of more than two optical channels. Our results shows that, using MO-EDFA, a point to multipoint architecture can be obtained, to feed up to 24 RRHs with 4x192 different LTE-A radio waveforms, that can then be freely selected by DSP at each RRH, for a full reconfigurability that may be very handy in future Cloud Radio Access Network (C-RAN). The total bit rate that would be required to transmit the same channels by using CPRI would be around 768 Gb/s. The OPL values obtained in our experiments are about 25 dB, which would not allow using a standard ITU-T Passive Optical Network (PON) architecture on each of the MO-EDFA single outputs, since ITU-T PON requires at least OPL=29 dB. Anyway, the results we have shown demonstrate a wide margin in a reference scenario envisioning a point-to-point fiber from each MO-EDFA output fiber to each RRH input port, as depicted in Fig. 1.

Acknowledgements

This work was supported by CISCO under an SVCF grant titled "5G-PON". P. Torres-Ferrera also acknowledges the support of CONACyT, Mexico, and DGAPA – UNAM through PAPIIT grant IN103416. Finally, we thank Tektronix for lending us the high-speed AWG used in these experiments.

References

- [1] X. Liu, H. Zeng, N. Chand, F. Effenberger, "Efficient Mobile Fronthaul via DSP-Based Channel Aggregation", *IEEE Journal of Lightwave Technology*, vol. 34, no. 6, pp. 1556-1564, 2015.
- [2] M. Befekadu, S. Straullu, S. Abrate and R. Gaudino, "Experimental Optimization of DSP-Aggregated Fronthauling Transmission for up to 4x96 LTE radio waveforms", *Optical Communication (ECOC)*, 2016 42th European Conference and Exhibition on; Dusseldorf, September 2016.
- [3] P. Torres-Ferrera, S. Straullu, S. Abrate and R. Gaudino, "Alternative Solutions for Fronthauling based on DSP-assisted Radio-over-Fiber," *Transparent Optical Networks (ICTON)*, 2017 19th International Conference on; Girona, July 2017, [Forthcoming].
- [4] F. Forghieri, R. W. Tkach and A. R. Chraplyvy, "WDM systems with unequally spaced channels," *Journal of Lightwave Technology*, vol. 13, no. 5, pp. 889-897, 1995.