

On the role of additive manufacturing, heat treatment and machining on the microstructural evolution and corrosion behaviour of AlSi9Cu3(Fe) alloy

*Original*

On the role of additive manufacturing, heat treatment and machining on the microstructural evolution and corrosion behaviour of AlSi9Cu3(Fe) alloy / Lagalante, Ilaria; Ghinatti, Edoardo; Martucci, Alessandra; Bertolini, Rachele; Bruschi, Stefania; Lombardi, Mariangela. - In: MATERIALS CHARACTERIZATION. - ISSN 1044-5803. - 224:(2025).  
[10.1016/j.matchar.2025.115089]

*Availability:*

This version is available at: 11583/2999774 since: 2025-05-02T13:39:36Z

*Publisher:*

Elsevier

*Published*

DOI:10.1016/j.matchar.2025.115089

*Terms of use:*

This article is made available under terms and conditions as specified in the corresponding bibliographic description in the repository

*Publisher copyright*

(Article begins on next page)

© 2020 IEEE. Personal use of this material is permitted. Permission from IEEE must be obtained for all other uses, in any current or future media, including reprinting/republishing this material for advertising or promotional purposes, creating new collective works, for resale or redistribution to servers or lists, or reuse of any copyrighted component of this work in other works.

***Electrochemical Impedance Spectroscopy System  
Based on a Teensy Board***

*Leila Es Sebar, Leonardo Iannucci, Emma Angelini, Sabrina Grassini  
Dipartimento di Scienza Applicata e Tecnologia, Politecnico di Torino, Torino, ITALY*

*Marco Parvis  
Dipartimento di Elettronica e Telecomunicazioni Politecnico di Torino, Torino,  
ITALY*

**DOI: 10.1109/TIM.2020.3038005**

# Electrochemical Impedance Spectroscopy System Based on a Teensy Board

Leila Es Sebar, *Student Member, IEEE*, Leonardo Iannucci *Member, IEEE*, Emma Angelini *Member, IEEE*, Sabrina Grassini, *Senior Member, IEEE* and Marco Parvis *Fellow, IEEE*

**Abstract**—This paper describes a portable low-cost device for performing Electrochemical Impedance Spectroscopy (EIS) measurements which is based on an off-the-shelf TeensyDuino. The instrument does not make use of other components like operational amplifiers so it can be readily set up by anyone having a Teensy device and some resistors. Teensy 3.2, 3.5 and 3.6 can be used to realize the EIS system. The instrument can measure the impedance in the frequency range from 0.01 Hz to 50000 Hz and by selecting the shunt resistor it can be adapted to different impedance values. No special instrumentation is required for the system calibration. The proposed system uncertainty is of less than 5% for an impedance of up to 50 kΩ, a value which is lower than the usual intrinsic uncertainty of most of corrosion experiments.

**Index Terms**—EIS, Arduino, low cost instrumentation

## I. INTRODUCTION

Electrochemical Impedance Spectroscopy (EIS) is a simple though extremely powerful and non invasive technique to assess the corrosion processes on metals and alloys as well as the electrochemical phenomena in coatings, lithium batteries, fuel cells, polymer science, and super-capacitors [1]–[5]. EIS has also been successfully used in the medical field [6]–[9] even though corrosion monitoring is still its basic application [10]. Unfortunately, up to now EIS requires complex and costly instrumentation to be performed, preventing its wide use in many industrial applications.

Several different devices have been proposed that can be used to lower the potentiostat cost [11]–[13]. Unfortunately most of the proposed systems either require the development of specific hardware or are tailored for specific electrochemical techniques which usually do not imply the EIS.

EIS consists in applying a small sinusoidal alternating voltage of different frequencies to a metallic sample while measuring amplitude and phase of the surface impedance when immersed in an electrolyte solution as described in Fig. 1.

EIS measurements are generally performed by using an electrochemical cell with a three-electrode configuration. The material whose surface has to be characterized is the working electrode; then, a reference electrode and a counter electrode (usually a wire of titanium or platinum) are employed to measure respectively the corrosion potential of the metal and the current flowing into it. The cell can be filled with electrolyte solutions of different corrosion aggressiveness,

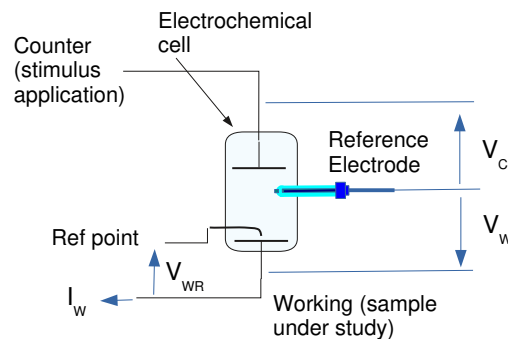

Fig. 1. Scheme of a conventional three-electrode electrochemical cell for EIS measurements.

such as sodium chloride ( $NaCl$ ) or sodium sulfate ( $Na_2SO_4$ ) in different concentrations, depending on the material that has to be studied. Generally concentration in the order of 0.1 M to 0.5 M are used in dependence on the corrosion phenomenon to be investigated, while lower concentrations are avoided in order not to have a high resistance between the working and counter electrodes [14].

The surface impedance  $Z_W$  is defined as the ratio between the alternating voltage applied to the working electrode and the alternating current flowing in it. At a specific frequency  $f$ :

$$Z_W(f) = \frac{V_{WR}(f)}{I_W(f)} \quad (1)$$

where  $V_{WR}(f)$  and  $I_W(f)$  are both complex numbers which in phasor notation represent the applied voltage and the flowing current.

When immersed in any electrolyte solution, both the working and counter electrodes reach an electrical potential which is usually referred to as 'Open Circuit Potential - OCP'. The values of such potentials can be found in the literature with respect to a reference electrode, the Standard Hydrogen Electrode (SHE) whose potential in standard conditions at 25 °C is set to 0.00 V [15]. Since such electrode is difficult to be used in common applications, usually other reference electrodes such as the Silver/Silver Chloride ( $Ag/AgCl$ ) or the Saturated Calomel Electrode (SCE), which have a fixed temperature-independent potential with respect to the SHE are used; the measured OCPs are usually in the range of few hundreds of millivolts. In corrosion studies, only the OCP of the working electrode is important because it gives information

L. Es Sebar, L. Iannucci, S. Grassini, E. Angelini, are with the Department of Applied Science and Technology, Politecnico di Torino, Italy.

M. Parvis is with the Department of Electronics and Telecommunications, Politecnico di Torino, Italy.

on the corrosion susceptibility of the metal in the environment which is exposed to; however, the voltage difference between the working and counter electrodes can be expressed as:

$$V_{WC} = V_W - V_C \quad (2)$$

where  $V_W$  is the OCP of the working electrode and  $V_C$  is the OCP of the counter electrode

Since the surface impedance of a bare metal could be very low, of the order of the solution resistance, in order to perform accurate measurements, this potential is generally measured with respect to an additional electrode (Fig. 1), which is positioned close to the working electrode. If the measurement of the OCP of the working electrode is not required and if the distance between the counter and the working electrodes is of less than 1 cm, thus the solution resistance can be neglected, a simplified two-electrode cell can be employed, dropping both the reference electrode and the additional point for measuring the applied voltage (Ref point). Such a two-electrode cell is shown in Fig. 2.

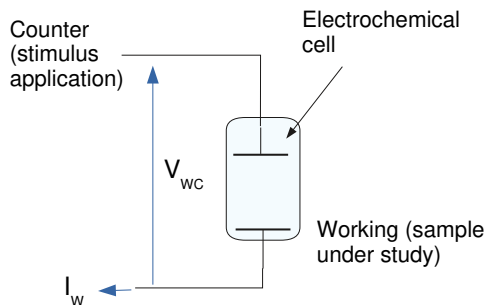

Fig. 2. Simplified 2-electrode electrochemical cell.

In this way only the current flowing through the working electrode and the voltage difference between the working and the counter electrodes have to be measured thus greatly simplifying the instrument architecture.

Of course, since corrosion is an electrochemical reaction, in order to avoid any effect on the working electrode surface, a zero mean current has to flow, and this requires applying an alternating stimulus whose mean value  $V_{WC}$  is close to the difference in the OCPs of the working and counter electrodes. This is usually obtained by employing a 'potentiostat', an expensive electronic device able to control the potentials across the cell in a wide range of positive and negative values which are not known in advance depending on counter and working electrodes.

Once the impedance  $Z_W$  is measured, the impedance spectra are usually fitted by using an equivalent circuit model, designed to represent the impedance of the working electrode/electrolyte interface. Several equivalent circuits have been proposed in the literature to model different physical systems; these models are generally based on simple electrical components, such as resistors and capacitors, constant phase elements (CPE) and Warburg elements (W) which try to model the complex electrochemical reactions and diffusion phenomena occurring on the electrode surface. The CPE is often used to take into account non-linear behaviors

(surface roughness, non uniform current distribution, diffusion phenomena, etc.) and have an impedance described by eqn. 3:

$$X = \frac{1}{C(j\omega)^n} \quad (3)$$

where  $\omega = 2\pi f$  represents the measurement frequency,  $j$  is the imaginary unit,  $C$  is the CPE value and  $n$  is an exponent ranging between 0 and 1; when  $n = 0$  the CPE behaves like a resistor, when  $n = 1$  the CPE behaves like a capacitor and when  $n = 0.5$  the CPE models a pure diffusion element, i.e. a Warburg element [16].

The general model to fit EIS data can be quite complex and composed by several components. In its most simplified version, it can be represented by a simplified Randles model [17] which was firstly introduced in 1947 (Fig. 3) and is based on two resistors and on a constant phase element (CPE). Depending on the surface characteristics, the resistors can be in the range of few ohms to several hundreds of megaohms and the constant phase element can have an exponent (eqn. 3) varying from 0.2 to about 1.0. Several other types of equivalent circuit models have been proposed in literature in order to model different electrochemical systems.

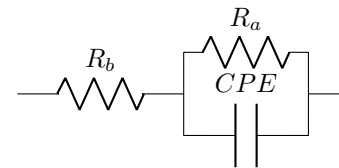

Fig. 3. Example of a simple equivalent circuit model for fitting EIS spectra as described by Randles in 1947.

Typically, EIS data are graphically represented as either a Bode or Nyquist plot, where the Bode plot employs a logarithmic scale and is useful to see large impedance changes, while the Nyquist plot, in linear scale, is used to have an overall description of the system, specifically in the low-frequency region, where higher impedance values are often measured.

As previously mentioned, EIS requires using a specific instrument capable of dealing with the OCP, stimulating the working electrode and estimating the surface impedance. Several EIS measurement systems are commercially available. As an example, the reader can refer to [18] to find products which are based on different technologies and which can work in rather different conditions. The cost of EIS instruments are commonly of the order of 10k\$ even though some small and limited devices have been proposed [19] with cost of the order of 500\$. Other low cost devices were recently developed [20,21] also by using commercial digital acquisition boards.

In this work a portable and extremely cheap device has been designed and developed. The proposed system has the advantage of giving fast response, not requiring the development of any component, not requiring any instrumentation for system calibration, and has a cost of the order of 25\$. Advantages and limitations of the proposed system are therefore discussed.

## II. THE PROPOSED EIS SYSTEM

The proposed EIS measuring system is based on a common off-the-shelf open source Teensy board [22]. Teensy boards have been used in many different fields [23]–[25]. All Teensy boards can be programmed in the Arduino environment [26] and a Java user interface [27] which runs on most operating systems can be used [28].

In order to keep the system extremely simple, the current measurement is obtained by estimating it from the voltage drop across a shunt resistor. From one side this choice does not complicate the system, but on the other side the current measurement is performed on a fixed scale thus limiting the overall instrument capabilities. The resistance can of course be changed to adapt the instrument to different situations, but during a single scan it cannot be changed so the design simplification is paid for with an uncertainty increase and with a limited impedance range with changing frequency.

Working with a single resistor means that the voltage across the resistance is linearly correlated to the current flowing through the working electrode:

$$V_r = R_s \cdot I_w \quad (4)$$

where  $R_s$  is the shunt resistance and  $I_w$  the current flowing through the working electrode and connected to the surface impedance of the working. Since the Teensy ADC has only 16 bits and usually such bits are not completely used in order to keep a limited value for  $V_r$ , the current ratio must be limited often to a range of less than four decades, and this limits the instrument capabilities to less than four decades of impedance.

One should note that by adding some components it would be possible to greatly expand the instrument capabilities while reducing its uncertainty. The proposed solution has been chosen to have a system extremely simple and suitable to be used even by not-trained people. Moreover if a Teensy shield could be added, also an audio output could be used. Unfortunately such a shield is usually not commonly present in many laboratories, so this possibility has not been investigated.

Furthermore, new boards have been introduced on the market, which have a much more powerful microcontroller than the ones used here, but which lack some of the specific capabilities like the DAC presence inside the microcontroller. Of course all these powerful microcontrollers have PWM capability on digital pins, but unfortunately the PWM cannot be employed for the wide EIS frequency range without the addition of other components, which would increase the complexity of the system.

With all these premises and with the idea of keeping the system as simple as possible the authors decided to design an EIS system equipped with an ARM 32 bits microcontroller which embeds all the required components, i.e.:

- a 12 bit DAC (Digital to Analog Converter) capable of generating an analogue signal in the range of 0 V to 3.3 V;
- two 16 bits ADCs (Analog to Digital Converters), capable of sampling signals with amplitudes in the range of 0 V to 3.3 V, which can be run in parallel. Some Teensy like the 3.1 and 3.2 are provided with a differential

Programmable Gain Amplifier (PGA) that can amplify the signal sent to the ADCs up to 64, some other Teensy like the 3.5 and 3.6 do not have this PGA;

- a microcontroller core which embeds several timers which can be used to pace independently both the DAC and the ADCs and a large local memory for the code and for storing the acquired data;
- an USB connection to transfer data to any Personal Computer.

The most recent Teensy series is the fourth one, i.e. Teensy 4 and subsequent, but even though the microcontroller installed on this type of Teensy is extremely fast and powerful, it lacks the DAC component, which is fundamental in this type of project and therefore the Teensy 4 can not be used. Teensy versions which appeared before version 3 (i.e. Teensy 2) are difficult to find and lack other capabilities, so the only practical alternative is to use the Teensy 3 series.

The Teensy 3 series is actually composed of three types of devices which are coded as 3.2, 3.5 and 3.6. They appeared on the market in sequence and are of increasing power, but have different limitations:

- Teensy 3.2 is the less powerful microcontroller, but it is the only device that embeds a Programmable Gain Amplifier (PGA) in front of each ADC. Such a PGA can amplify the signal of powers of 2 up to 64 and this might be important especially for the current channel, where the voltage across the shunt resistance can be very small, especially if the unknown impedance reaches high values. The PGA can accept negative voltages, provided that the inputs remain within the allowed voltage range. The specifications are given only for a range of 1.2 V, but this is usually not a problem since in most cases the  $V_{WC}$  is within this range. Unfortunately, the PGA have an input resistance which is quite low: 128 k $\Omega$  for gains up to 8 and only 32 k $\Omega$  for a gain of 64 and, in addition, such input resistance has a large uncertainty which depends also on the input impedance. Trying to correct the effect of such an input resistance might turn out in an unacceptable uncertainty. Moreover, the Teensy 3.2 has a bus frequency which is of only 60 MHz and a limited computing power.
- Teensy 3.5 and 3.6 do not embed any PGA so the voltage drop across the shunt resistor can not be amplified, but the ADC input resistance is definitely higher than the one of Teensy 3.2 with the PGA, in excess of 100 M $\Omega$  so higher impedance values can be measured. The ADC input impedance is not stated so its value should be estimated, but since values in excess of 1 M $\Omega$  are expected, usually no correction is required for an impedance up to 10 k $\Omega$  and uncertainties of few percents. The microcontrollers in both Teensy 3.5 and 3.6 have ADCs that can work either in single mode or in differential mode. By using the differential mode the ADCs have a better performance, but two pins are required for each ADC. Unfortunately, on Teensy 3.5 and 3.6 boards only one ADC has these two pins routed to external points, so one of the ADCs must be used as a single ended ADC. One should note

that since two different ADCs are used without switching the input channels, also the cross-talk is negligible for this circuit.

An EIS measuring system therefore can be arranged as detailed in Fig. 4 where both the Teensy 3.2 and Teensy 3.5-3.6 solutions are presented. These configurations avoid any hardware correction for the input impedance and thus are suitable for measuring a not extremely high impedance.

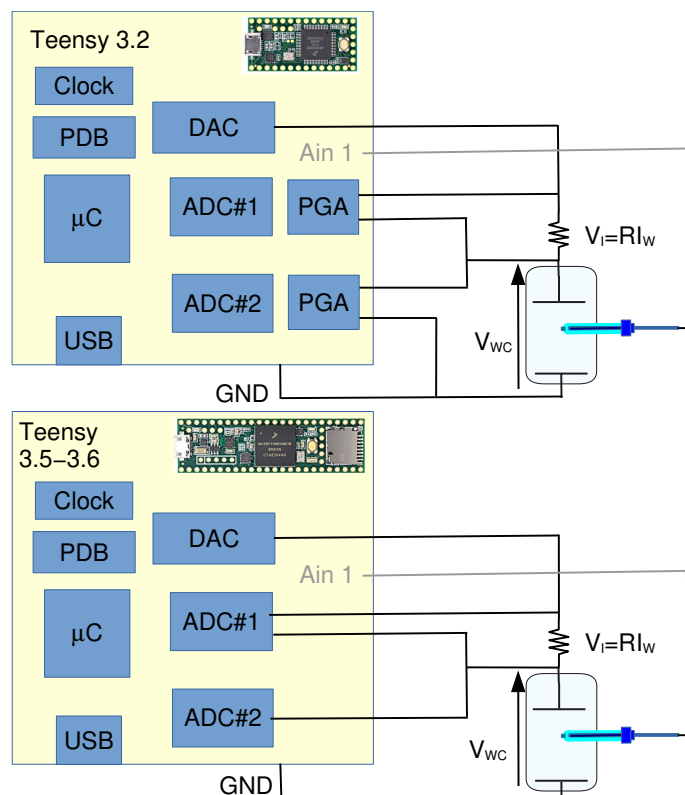

Fig. 4. The two proposed Teensy-based EIS systems.

The figure shows:

- The simplified electrochemical cell with the reference electrode. Since Teensy can measure only positive voltage and the OCP of counter and working electrodes are different, there is the possibility of having to exchange working and counter. In any case the impedance measurement is not affected by this exchange and the impedance is always related to the working electrode. The reference electrode, shown in the picture is not required for the system to work, but it can be added to measure the OCP if required. Of course if working electrode and counter electrode have to be exchanged such an exchange need to be taken into account when measuring the OCP.
- The Programmable Delay Block (PDB), which is used to trigger both ADCs and the DAC in hardware thus allowing a sampling rate fixed and connected to the Teensy clock. ADCs and DAC are linked to interrupt routines which have to return before the next PDB clock, so the maximum frequency of the PDB is limited by the interrupt routine complexity and by the microcontroller speed. The authors found that in the case of Teensy

3.2, 3.5 and 3.6, a maximum PDB speed of 200 kHz, 250 kHz and 500 kHz could be achieved, respectively, which is the maximum speed which can be used for sampling the signals.

- The DAC which is used to generate the stimulus signal. The average voltage needs to be equal to the voltage difference between working and counter electrodes and the DAC output can be (electronically) disconnected from the cell when the  $V_{WC}$  has to be measured. The DAC has a resolution of 12 bits and a maximum output of either 3.3 V or 1.2 V. If the 1.2 V range is used in order to increase the output resolution, this corresponds to about  $300 \mu\text{V}$  for each bit so that generating an AC of 10 mV of peak means using about  $\pm 30$  different codes. For speed reasons, to avoid computing the samples in real time, the signal to be generated is stored in a look-up table with the digital codes corresponding to the alternating voltage superposed to the voltage difference  $V_{WC}$  between working and counter electrodes.
- The resistor which is used as shunt to allow the current measurement to be performed. The resistor value has to be chosen according to the expected impedance. Typical values are in the range from  $100 \Omega$  to  $10 \text{ k}\Omega$  and higher values are usually adopted on Teensy 3.5-3.6 which lacks the PGA facility.
- The ADC#1 block is used to measure the shunt voltage and to estimate the current. If the Teensy 3.2 is used, the maximum input range has to be set at 1.2 V and the PGA gain can be set to higher values, since the voltage across the shunt can be small. PGA has a maximum amplification of 64, so a theoretical ADC sensitivity of  $\pm 0.6 \mu\text{V}$  can be obtained which corresponds to a current of about  $60 \text{ pA}$  with a shunt of  $10 \text{ k}\Omega$ . One should note that the ADC even though has a resolution of 16 bits, is declared to have slightly more than 13 bits of accuracy so these values should be increased of more than one order of magnitude. If the Teensy 3.5-3.6 are used, the absence of PGA does not allow one to amplify the voltage across the shunt resistor so the theoretical resolution with an input range of 1.2 V is of about  $35 \mu\text{V}$  and the current resolution with a shunt resistor of  $10 \text{ k}\Omega$  is of about  $3.5 \text{ nA}$ .
- The ADC#2 which is used to measure the voltage between working and counter and if required to measure also the reference electrode voltage. Also in this case the voltage range can be set to 1.2 V to increase the resolution. When the voltage difference between working and counter has to be measured, the DAC output is (electronically) disconnected and disabled so no current flows through the unknown impedance. When the EIS has to be measured, ADC#2 directly measures the voltage across the unknown impedance therefore avoiding to measure the voltage drop on the shunt resistor. This ADC is also used on a specific input channel if the reference electrode is present and its voltage has to be measured. In the Teensy 3.2 the ADC is connected to the PGA block to measure the differential voltage applied to the cell even though in this case usually a low amplification

is used since the voltage difference between working and counter has to be measured. If the Teensy 3.5-3.6 are used, the PGA is not present as well as the differential input, so the measured voltage has to be positive, but the sensitivity can be doubled since all 16 bits can be used for the measurement on a uni-polar range.

- The USB interface which can be employed to transfer all data to the PC and is used with a baud rate of 115200 bit/s. By using this baud rate, more than 10000 characters per second can be easily transmitted and the speed can be tolerated by any PC.

Regardless of the used Teensy board, the proposed system for each stimulation frequency has to:

- Select a PDB time interval  $T_s = f_{pdb}$ .
- Load a look-up table for the generated signal and start the generation:

$$S_i = S_0 + A \sin(2\pi f T_s) \quad (5)$$

where  $S_i$  are the values inserted into the look-up table,  $S_0$  is the zero value measured during the OCP period,  $A$  is the signal amplitude,  $f$  is the generated frequency, and  $T_s$  is the PDB time interval. All values need to be scaled in the range 0 – 4095.

- Acquire the samples on Voltage ( $S_{Vi}$ ) and Current ( $S_{Ii}$ ) channels by using the same PDB as before.
- Fit the samples to the input (known) generated frequency  $f$  by solving a 3-parameter least square estimation:

$$S_{Vi} = v_0 + v_1 \cos(2\pi f T_s) + v_2 \sin(2\pi f T_s) \quad (6)$$

$$S_{Ii} = i_0 + i_1 \cos(2\pi f T_s) + i_2 \sin(2\pi f T_s) \quad (7)$$

where  $S_{Vi}$  are the voltage sample values,  $v_0$  is the offset value, close to  $V_{WC}$ ,  $v_1$  and  $v_2$  are the voltage cosine and sine components,  $S_{Ii}$  are the current sample values,  $i_0$  is the offset value, close to zero if  $V_{WC}$  is correctly estimated,  $i_1$  and  $i_2$  are the current cosine and sine components, and  $T_s$  is the acquisition sampling interval.

- Compute the measured impedance  $Z_m$  at the frequency  $f$  as:

$$Z_m = \frac{v_1 + jv_2}{i_1 + ji_2} \quad (8)$$

- If necessary, i.e. if in the input resistance is not high, estimate the unknown impedance  $Z$  by removing the effect of the ADC input impedance  $R$  supposed to be a resistance as:

$$Z = \frac{R \cdot Z_m}{R - Z_m} \quad (9)$$

Even though at first it could seem that the Teensy 3.2 based system is a better solution [28] due to the PGA presence and the possibility of increasing the gain, the low input resistance of PGA channels can reduce the measuring capability and increase the uncertainty. In addition, according to the manual of the microcontroller installed on the Teensy 3.2, the PGA gain decreases as the external resistance viewed by the PGA increases, but no specific values are given. Both these effects request a specific calibration and prevent measuring high

impedance values, while the more recent Teensy 3.5 and 3.6 with their power can help increasing the measuring capabilities and should not require an advanced calibration.

### III. MEASUREMENTS ON KNOWN COMPONENTS

Initially the proposed system has been assessed by using measurable components with known impedance spectra, always keeping limited the maximum impedance.

#### A. Test for different working-counter voltages

The first measurements are performed to test the system behavior with respect to the voltage difference between working and counter electrodes and to see if the differential system used for measuring the current works correctly. For this test a simple circuit as shown in Fig. 5 has been used.

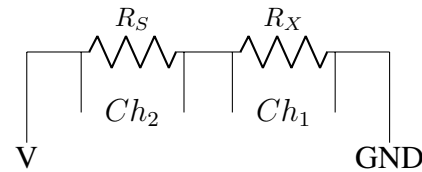

Fig. 5. Circuit used for the working-counter voltage test.

By using this circuit it is easy to preview the expected voltage across the shunt resistor  $R_S$  and the equivalent cell resistor  $R_X$  and it is easy to change the equivalent  $V_{WC}$  by changing the DAC offset. An AC amplitude of 0.1 V has been used with  $R_S = 5 \text{ k}\Omega$  for the Teensy 3.5-3.6 and  $R_S = 1 \text{ k}\Omega$  for the Teensy 3.2. The resistor simulating the cell remained fixed in all cases:  $R_X = 10 \text{ k}\Omega$ . In the case of Teensy 3.2 the PGA gains were set to 1. The frequency of the AC voltage was set to 170 Hz to avoid interference with mains and to use a frequency easy to manage for all Teensy.

The voltages on  $R_S$  and  $R_X$  were scaled to have unity values and make the comparison easy.

Fig. 6 shows the results obtained with the different Teensy boards. It is easy to observe how, regardless of the device, the offset correction works correctly with uncertainty on the voltage measurements of less than 1% and on the current measurements of less than 5%. Also it is clear how the Teensy 3.2 is slightly less performing on the current channel mainly due to the limited voltage difference due to the lower  $R_S$  resistance, while the Teensy 3.6 performs better with an uncertainty of less than 1% on all the range.

For this reason, for the sake of simplicity, only the results obtained with the Teensy 3.6 are presented in the following sections, while other results, obtained using Teensy 3.2 can be found in [28].

#### B. Impedance test with a simulated cell

The proposed system has been tested with the circuit shown in Fig. 3 which represents a simplified Randles circuit [17] with a standard capacitor instead of a CPE and different values of resistance and capacitance. This type of circuit is

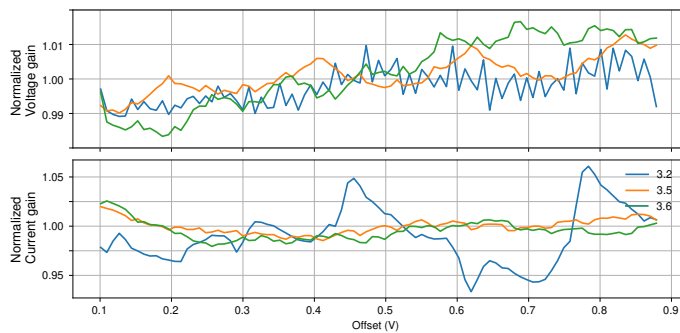

Fig. 6. Results obtained with equivalent differences between working and counter electrodes acquired by changing the DAC offset in the range of 0.1 V to 0.9 V.

commonly used to verify the acquisition system behavior of several commercial measuring systems. The proposed solution has been compared both to a small and low-cost commercial system (PalmSense® Sensit Smart) which has a stated accuracy of 0.5% on the voltage and of 1-2% on the current depending on the current range and to the theoretical values obtained by using the nominal values of the components which compose the simplified Randles circuit shown in Fig. 3. Resistances have an uncertainty of 1%, while the capacitors have an uncertainty of 10%. Four sets of values have been used to check the system behavior in the presence of different types of surface impedance, reported in Table I.

Fig. 7 shows, as an example, the Teensy 3.5-3.6, Teensy 3.2 and the low-cost commercial device mentioned above, which however has a cost about 20 times higher the proposed solution.

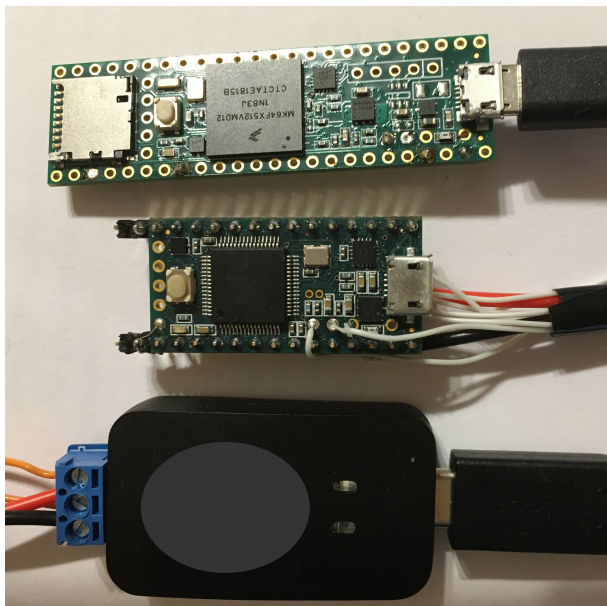

Fig. 7. Picture of the proposed system based on Teensy 3.5, 3.6 (at top), of a 3.2 (in the middle) and of the commercial system (at bottom) used for the comparison. All devices are quite small, the Teensy 3.2 has a dimension of about 4 cm × 2 cm and a cost of about 20\$, the Teensy 3.5-3.6 have dimension of about 6 cm × 2 cm and a cost of about 20\$, and the commercial device has a dimension of about 4.5 cm × 2.5 cm and a cost of about 500\$.

Impedance	$R_1$	$R_2$	$C$
Low	250 $\Omega$	250 $\Omega$	4.7 $\mu\text{F}$
Medium	250 $\Omega$	15 k $\Omega$	47 nF
High	470 $\Omega$	47 k $\Omega$	47 nF
Very High	470 $\Omega$	110 k $\Omega$	10 nF

TABLE I

NOMINAL VALUES OF THE DIFFERENT RESISTANCE AND CAPACITANCE USED FOR THE RANDES EQUIVALENT SIMULATED CELL WITH A FIXED CAPACITOR INSTEAD OF A CPE.

Impedance	Max. Value	Commercial Err%	Teensy Err%
Low	500 $\Omega$	1.3	3.8
Medium	15 k $\Omega$	1.1	3.5
High	47 k $\Omega$	2.1	5.2
Very High	110 k $\Omega$	1.0	9.9

TABLE II

AVERAGED PERCENT DIFFERENCES BETWEEN THEORETICAL AND MEASURED IMPEDANCE VALUES FOR THE COMMERCIAL AND THE TEENSY BASED EIS SYSTEM.

Assessing the uncertainty of the different systems is quite difficult as the expected impedance greatly changes with the frequency. In addition, two elements need to be taken into account:

- while the Teensy proposed system has only one current range once the measurement has started, all commercial devices change the current range during the measurement;
- the stated uncertainty of the commercial systems is usually given with respect to the maximum value of the actual current range, but the current range changes during the measurement in a not predictable way.

The measured impedance can change of more than three decades, so simply computing the difference between theoretical and real measurements cannot directly be used as an uncertainty indication as similar values with very high impedance might give great though not important differences. For this reason the authors decided to compute the relative value of the uncertainty:

$$Err\% = 100 \cdot \frac{Z_m - Z_t}{Z_t} \quad (10)$$

where  $Err\%$  is the percentage of measurement error,  $Z_m$  is the measured impedance value and  $Z_t$  is the theoretically expected impedance value.

This way of computing the error does not take the phase error into account, but only the impedance amplitude difference. However the phase estimation is performed by estimating sine and cosine components of current and voltage, and these values share the same data used for the modulus. As sine and cosine components are affected in the same way, the phase uncertainty is not so important, thus the proposed solution can be considered a suitable choice for computing the measurement error.

Table II shows the difference between the theoretical values as expected by Table I and the values obtained by the commercial and the Teensy based system computed according to eqn. 10

Fig. 8 shows as an example impedance modulus, the phase reversed to have it positive, and percent difference between the

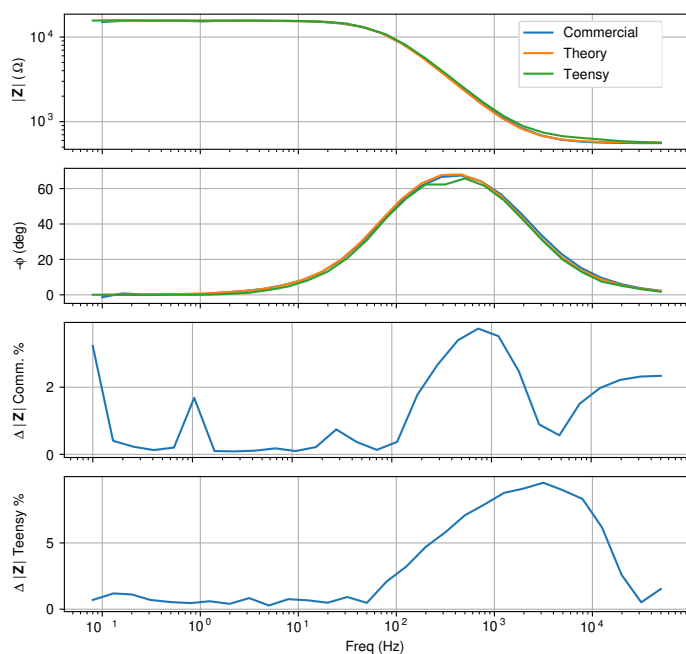

Fig. 8. At top: impedance spectra, presented as Bode diagrams, for the 'Medium Impedance' circuit (see Table I). At bottom: percent error of measurements performed using the commercial device and the Teensy 3.6 proposed system with respect to the theoretical expected values.

modulus of measured and expected values in the case of the medium impedance. For the commercial system the maximum difference is of the order of 4%, which is compatible with the stated uncertainty of the device and the components. For the Teensy based, the maximum difference reaches about 10%, when the impedance becomes very low, at high frequencies

It is clear how the proposed system gives the same values as the commercial device and such values are in agreement with the theoretical values up to an impedance of about 50 kΩ with a difference which is on the average of less than 5% without any either hardware or software correction and becomes less than 10% for impedance of the order of 100 kΩ.

The phase difference is slightly higher, with a maximum of the order of 3° for the commercial device and 7° for the proposed system up to 50 kΩ. Both measurements tend to estimate a lower phase, that means a lower capacitance value. In addition, fitting a model to the acquired data requires using a CPE instead of a capacitor. Making reference to eqn. 3 the obtained result for the CPE exponent is  $n = 0.995$ . This suggests that the used capacitor is not a real capacitor, but this does not harm the proposed system test.

#### IV. MEASUREMENTS ON REAL METALLIC SAMPLES

Comparison measurements on metallic samples have been obtained again by using the proposed system and the commercial device already used in previous section. The measurements have been performed on a *Corten*<sup>(TM)</sup> weathering steel sample by using a small two-electrode cell designed at Politecnico di Torino [29]. One should note that in this case it is not possible to obtain a real comparison because the measurements have to be performed on the same sample area by means of the two devices; therefore, the measurements

have to be carried out in different times and, of course, the thin corrosion products layer, which covers the sample, tends to change over time due to the interaction with the electrolyte. Several measurements have been performed to assess the drift effect.

Fig. 9 shows subsequent measurements on the Corten sample performed with the Teensy 3.6 immediately after the electrode has been positioned, and after about 20 min, 40 min, 2.5 hours and 3.5 hours, respectively. The employed two-electrode electrochemical cell is shown on the inset on the right top of the figure: it has a platinum (Pt) wire as the counter electrode and it is filled with a 0.1 M  $Na_2SO_4$  solution. The exposed surface area is about 0.5 cm<sup>2</sup> and no normalization has been performed on the obtained data. The figure clearly shows the change in the impedance spectrum due to the interaction between the corrosion products layer and the electrolyte, highlighting the impossibility of a complete comparison with the commercial system.

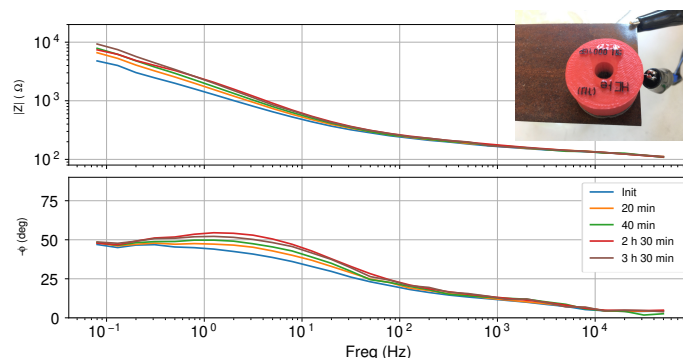

Fig. 9. Repeated measurements with the Teensy 3.6 on the same Corten sample to show the change of the impedance spectrum with increasing exposure time to the electrolyte solution. At top right a picture of the two-electrode cell used for the measurements.

Anyway, Fig. 10 shows the first measurements performed with the commercial system and with the Teensy 3.6 system. One should note that the Teensy system is able to complete the EIS measurement in a couple of minutes, while the commercial needs more than 15 min to collect the spectrum. Apart from a slight phase difference at high frequencies, the two spectra are in good agreement with a slight impedance increase detected by the commercial system at low frequencies probably due to the time it requires for the measurement. The plot lower part shows the impedance difference between the Teensy and the Commercial device showing that the difference is always below 500 Ω, i.e. below 8% notwithstanding the time used for the measurement.

#### V. CONCLUSIONS

This paper describes a complete system for performing electrochemical impedance spectroscopy for corrosion monitoring. It is based on an off-the-shelf Teensy board and it does not require any additional operational amplifiers. Only a fixed resistor is required to setup the measuring system. In addition, the proposed system is based on an open-source software so it can be tailored to fit any measurement requirement. The system, even though has some limitations,

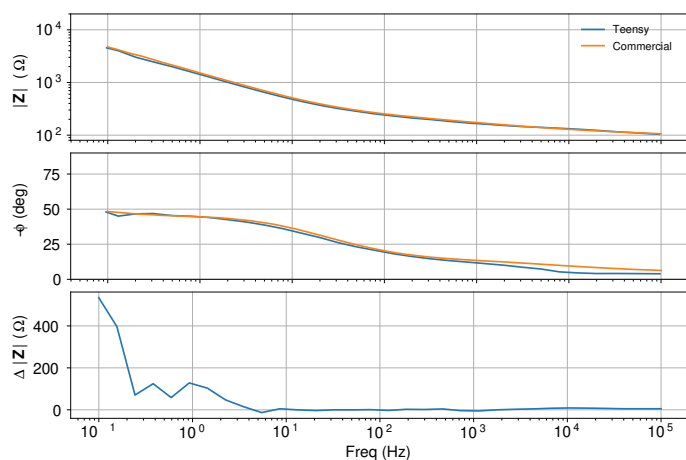

Fig. 10. On top: the impedance spectra, presented as Bode diagrams, acquired using a commercial device and the Teensy 3.6 proposed one. At bottom: difference between the two measurements.

is cheap and easy to be arranged, allowing to increase the use of EIS measurements in many applications. Eventually, the EIS measuring system here described could be an interesting solution for didactic laboratory activities, allowing students to perform EIS measurement on their samples setting up themselves their own device [30].

## REFERENCES

[1] L. Iannucci et al. 'Electrochemical characterization of innovative hybrid coatings for metallic artefacts. *European Physical Journal Plus* Vol. 133, no. 522, pp. 1-7, 2018

[2] A. Guha, A. Patra, 'Online Estimation of the Electrochemical Impedance Spectrum and Remaining Useful Life of Lithium-Ion Batteries, *IEEE Transactions on Instrumentation and Measurement*, vol. 67, no. 8, pp. 1836-1849, 2018

[3] G. Dotelli et al., 'Analysis and Compensation of PEM Fuel Cell Instabilities in Low-Frequency EIS Measurements' *IEEE Transactions on Instrumentation and Measurement*, vol. 63, no. 7, pp. 1693-1700, 2014

[4] Lei Wang et al. 'EIS study of polyurethanes coatings on galvanized sheet by UV ageing' 2011 International Conference on Remote Sensing, Environment and Transportation Engineering, vol. 1 no. 1 pp. 3136-3138, 2011

[5] M. Marracci et al. 'Ultrapacitor Degradation State Diagnosis via Electrochemical Impedance Spectroscopy', *IEEE Transactions on Instrumentation and Measurement*, vol. 64, no. 7, pp. 1916-1921, 2015

[6] S. Tsai et al. 'EIS algorithm based on single-cell impedance system,' 2013 1st International Conference on Orange Technologies (ICOT), Tainan, 2013, pp. 115-118, 2013

[7] Y.A. Glickman et al., 'Novel EIS postprocessing algorithm for breast cancer diagnosis', *IEEE Transactions on Medical Imaging*, vol 21, no 6, pp. 710-712, 2002

[8] Tung-Ming Pan et. al, 'High-k  $Tm_2Ti_2O_7$  Electrolyte-Insulator-Semiconductor Creatinine Biosensor', *IEEE Sensors Journal*, vol. 11, no. 10, pp. 2388-2394, 2011

[9] R.H. Smallwood et al. 'Electrical impedance spectroscopy (EIS) in the urinary bladder: the effect of inflammation and edema on identification of malignancy', *IEEE Transactions on Medical Imaging*, vol 21, no 6, pp. 708-710, 2002

[10] L. Iannucci et al, A Novel Approach for Microbial Corrosion Assessment, *IEEE Transactions on Instrumentation and Measurement* Vol. 68, no. 5, pp. 1424-1431, 2019

[11] Arevalo-Ramirez, Tito et al. Low cost potentiostat: Criteria and considerations for its design and construction. pp. 1-4, 2016 DOI: 10.1109/ANDESCON.2016.7836211.

[12] Rowe, Aaron et al. CheapStat: An Open-Source, "Do-It-Yourself" Potentiostat for Analytical and Educational Applications. *PLoS one*, 6, 2016, DOI:10.1371/journal.pone.0023783.

[13] Yuguang C. Li et al. An Easily Fabricated Low-Cost Potentiostat Coupled with User-Friendly Software for Introducing Students to Electrochemical Reactions and Electroanalytical Techniques, *Journal of Chemical Education* vol. 95 no. 9, pp. 1658-1661, 2018, DOI: 10.1021/acs.jchemed.8b00340

[14] Qing Huang et al. The Effect of Electrolyte Concentration on Electrochemical Impedance for Evaluating Polysulfone Membranes *Environ. Sci.: Water Research & Technology*, vol. 4 no. 8, pp. 1145-1151, 2018

[15] Corrosion website freely available at <http://www.corrosion-doctors.org/References/hydrogen.htm> last checked 2020-07-20

[16] Allen J. Bard, Larry R. Faulkner *Electrochemical Methods: Fundamentals and Applications*, 2nd edition, Wiley and sons, 2001

[17] Randles, J. E. B. "Kinetics of rapid electrode reactions". *Discussions of the Faraday Society*. Vol. 1: pp. 11-19, 1947

[18] Ametek website freely available at <https://www.ameteksi.com/products/frequency-response-analyzers> last checked at 2020-07-20.

[19] PalmSens website freely available at <https://www.palmsens.com/frequency-response-analyzer/> last checked at 2020-07-20

[20] Grossi, M. et al "Electrical Impedance Spectroscopy (EIS) characterization of saline solutions with a low-cost portable measurement system", *Eng. Science and Technology*, vol. 22, no. 1, pp. 102-108, 2019

[21] S. Grassini et al, Low-Cost Impedance Spectroscopy System Based on a Logarithmic Amplifier, *IEEE Transactions on Instrumentation and Measurement*, vol. 64 no. 5, pp. 1110-1117, 2014

[22] PJRC, <https://www.pjrc.com/store/index.html> freely available on the internet, last checked on 2020-07-20

[23] I. Al-Bahadly and J. Thompson, "Garden watering system based on moisture sensing," 2015 9th International Conference on Sensing Technology (ICST), Auckland, Vol. 1 no. 1, pp. 263-268, 2015

[24] H. Katdare, N. Warke and P. Vaidya, "Design and Construction of Low Cost High-Performance Transducer Signal Processing and Data Acquisition System," 2020 4th International Conference on Trends in Electronics and Informatics (ICOEI)(48184), Tirunelveli, India, Vol. 1 no. 1, 2020, pp. 48-52, 2020

[25] G. Baustista et al., "Myoelectric Sensor-Based Prosthetic Hand for the Transradial Amputees of Kapampangan Development Foundation, Inc.," 2019 IEEE 11th International Conference on Humanoid, Nanotechnology, Information Technology, Communication and Control, Environment, and Management (HNICEM), Laoag, Philippines, Vol. 1 no. 1, pp. 1-6, 2019

[26] Arduino download '<https://www.arduino.cc/en/Main/Software>', freely available on the internet, last checked on 2020-04-05

[27] Java <https://www.oracle.com/java/technologies/javase-jdk14-downloads.html>, freely available on the internet, last checked on 2020-07-20

[28] L. Es Sebar et al. 'An op amp-less Electrochemical Impedance Spectroscopy System', I2MTC 2020 Dubrownik

[29] E. Angelini et al., Corrosion Prediction of Metallic Cultural Heritage Assets by EIS, *Corrosion Science and Technology*, Vol.18, No.4, pp.121-128, 2019

[30] L.Iannucci et al 'iHomeX: An Internet-Enabled Laboratory for Long-Term Experiment Management', *IEEE Transactions on Instrumentation and Measurement*, vol 67, no. 5, pp. 1142-1149, 2018



**Leila Es Sebar** was born in Italy, in 1993. She received her M.S. degree in Materials Science for Cultural Heritage from the Università degli Studi di Torino, Italy, in 2018. She is currently a PhD student in Metrology at the Politecnico di Torino. Her research activities deal with the development of a multi-analytical measurement approach for the conservation assessment of cultural heritage artefacts.



**Leonardo Iannucci** was born in Italy, in 1992. He is currently a research fellow at Politecnico di Torino in the Department of Applied Science and Technology. He got the M.S. degree in Materials Engineering in 2016 and then in 2019 he received the PhD in Metrology from Politecnico di Torino. His main research fields are corrosion science, electrochemical measurements and materials characterization.



**Emma Angelini** was born in Torino in 1951, was graduated in Chemistry at Torino University. She is in Politecnico di Torino since 1976 and is now Full Professor of Applied Physical Chemistry with the Department of Applied Science and Technology, Politecnico di Torino. She is Vice-President of the International Corrosion Council (ICC). Her research areas are: Corrosion and protection of metallic materials, as stainless steels, amorphous and nanocrystalline alloys, biomaterials for dentistry, tangible Cultural Heritage; plasma chemistry and coatings deposition. She is involved in National and European projects on corrosion and protection of metals and is member of the European Federation of Corrosion (EFC).



**Sabrina Grassini** was born in Italy in 1972. She received her M.S. degree in Chemistry in 1999 from the University of Torino, Italy, and her Ph.D. degree in Metallurgical Engineering in 2004 from Politecnico di Torino, Italy. Currently she is professor of Applied Physical Chemistry with the Department of Applied Science and Technology, Politecnico di Torino. Her researcher areas include plasma chemistry, coating deposition, sensors, corrosion and protection of metallic materials, and conservation of cultural heritage.



**Marco Parvis** was born in Italy in 1958. He received his MS degree in electrical engineering in 1982 from the Politecnico di Torino, Italy, and a Ph.D. degree in Metrology in 1987 from the same university. He is now full professor of Electronic Measurements at the Politecnico di Torino, where he was Dean of the II Faculty of Engineering and chair of the TC 25 Medical Measurement of the IEEE Society on Instrumentation and Measurement. He is and Fellow Member and Vice President Technical Committees of the IEEE Society on Instrumentation and Measurement. His main fields of interest are: intelligent instrumentation, application of signal processing to measurement, biomedical and chemical measurements. He is author of more than one hundred publications.