

VITAL-ECG : a de-bias algorithm embedded in a gender-immune device

Original

VITAL-ECG : a de-bias algorithm embedded in a gender-immune device / Paviglianiti, A; Pasero, E. - ELETTRONICO. - (2020), pp. 314-318. (2020 IEEE International Workshop on Metrology for Industry 4.0 & IoT Roma 3-5 June 2020) [10.1109/MetroInd4.0IoT48571.2020.9138291].

Availability:

This version is available at: 11583/2849890 since: 2020-10-26T17:59:49Z

Publisher:

IEEE

Published

DOI:10.1109/MetroInd4.0IoT48571.2020.9138291

Terms of use:

This article is made available under terms and conditions as specified in the corresponding bibliographic description in the repository

Publisher copyright

IEEE postprint/Author's Accepted Manuscript

©2020 IEEE. Personal use of this material is permitted. Permission from IEEE must be obtained for all other uses, in any current or future media, including reprinting/republishing this material for advertising or promotional purposes, creating new collecting works, for resale or lists, or reuse of any copyrighted component of this work in other works.

(Article begins on next page)

VITAL-ECG : a de-bias algorithm embedded in a gender-immune device

Annunziata Paviglianiti

DET - Department of Electronics and Telecommunications
Politecnico di Torino
Turin, Italy
annunziata.paviglianiti@polito.it

Eros Pasero

DET - Department of Electronics and Telecommunications
Politecnico di Torino
Turin, Italy
eros.pasero@polito.it

Abstract - Artificial intelligence, sensors technology and sensors networks influence people behavior in everyday life. The diffusion of mobile devices, based on Internet of Things (IoT) paradigms, has created specific solutions for applications, in which physical objects are connected to Internet system. Wearable IoT (WIoT) represents a new IoT area, concerning detection, processing and communication capabilities in the field of healthcare. Vital-ECG is a smart device, related to health monitoring, which complies with gender equality. The wearable device takes the form of a smartwatch, which monitors heart activity and the most important vital parameters: blood oxygen saturation, skin temperature and fatigue level. Electrocardiogram and plethysmogram signals are acquired from Vital-ECG, which is able to track the blood pressure values, through a deep learning implementation. The neural algorithm has been implemented avoiding the "Gender Bias". The gender balance in machine learning, especially in biomedical application, is a crucial point to prevent algorithms from making a distorted prediction, disadvantaging women.

Keywords— *arterial blood pressure, ECG, electrocardiogram, fairness, gender bias, machine learning, plethysmogram, photoplethysmogram, PPG, VITAL-ECG.*

I. INTRODUCTION

Wearable computing devices have recently aroused the interest of the medical community. The increase in healthcare costs, the lengthening of average lifespan and the predominance of cardiovascular diseases generate the need for continuous monitoring of vital parameters to safeguard population health. The development of personal mobile devices is a way to facilitate person-centered assistance by leveraging data detection, processing and communication [1]. Cardiovascular disease is the leading cause of death worldwide (for both men and women). However, CVDs develop 7-10 years later in women than in men. The risk of heart disease in women is underestimated, due to the under-recognition of diseases and the difference in the onset of symptoms in women, which lead to less accurate treatment solutions. Furthermore, the identification of women cardiovascular risk factors requires more attention, and consequently continuous monitoring of cardiac activity[2]. According to [3], in the past two decades the myocardial problems have increased in middle-aged (35 to 54 years) women, while declining in similarly aged men. The importance of continuous health monitoring to avoid the onset of irreversible diseases is combined with the use of wearable devices, which safeguard health and produce an

alert in dangerous situations. In this particular scenario, the use of gender-immune wearable devices is important to ensure the necessary attention to cardiovascular disease in a fair way. There are real physiological differences between men and women; in the case of wearable technology these differences can disadvantage the detection of dangerous conditions in female subjects [4]. In this paper, the Vital-ECG technology (coupled with a mobile app) is presented: this tool can track bio-parameters, such as electrocardiogram, SpO₂, skin temperature, and physical activity of the patient [5]. Several studies have demonstrated that arterial blood pressure (ABP) has a close relation with cardiovascular disease [6]. For this reason, the VITAL-ECG has been enriched with a machine learning (ML) algorithm, capable of detecting blood pressure values. It is necessary to guarantee a correct prediction of the arterial blood pressure values, regardless of the gender difference. Equity is an increasingly important concern as machine learning models are used to support decision making in high-risk applications, especially in healthcare [7]. In this study, the implementation of the neural network for the prediction of blood pressure values is presented. In addition, a de-bias technique to make the algorithm fair will be illustrated.

After the explanation of the term "Gender Medicine" in Sec. II, Sec. III contains VITAL-ECG description, the comparison with others vital parameters monitoring devices and a detailed illustration about the IoT paradigms on which VITAL-ECG is based. Sec IV shows the machine learning technique for ABP detection and a de-bias application in the ML algorithm. Finally, Sec. V yields the conclusions.

II. GENDER MEDICINE

The concept of Gender Medicine derives from the idea that the differences between men and women, in terms of health, are related not only to their biological characterization and reproductive functions, but also environmental, social, cultural and relational factors defined by the term "gender". The Organization World Health (WHO) defines "gender" as the result of social criteria about behavior, actions and roles attributed to male and female subjects [8].

Gender diversity manifests itself:

- In the state of health, in the incidence of multiple diseases, chronic or infectious, in environmental and pharmacological toxicity, in work-related pathologies,

mental health and disability, in all age groups (childhood, adolescence, the elderly).

- In the use of health services for prevention (screening and vaccinations), diagnosis, hospitalization, emergency medicine, use of drugs and medical devices
- In the experience of health, attitude towards disease, perception of pain, etc.

Therefore, the study of Gender Medicine represents the impact of biological, socio-economic and cultural differences on the state of health and illness of each person. Indeed, many diseases, which are common to men and women, have different incidence, symptoms and severity. In addition, men and women can also present a different response to therapies and adverse drug reactions.

Ensuring equity in medicine is an important step in the process of providing ad-hoc treatments and solutions to women, even in diseases that in most cases concern men. Only by proceeding in this direction it will be possible to guarantee to everybody the best care, further strengthening the concept of "patient centrality".

III. VITAL-ECG HARDWARE

Vital-ECG [9] is a wearable device, developed in the Neuronica Lab of Politecnico di Torino, able to record simultaneously ECG, PPG signals and others vital parameters. As shown in Fig. 1, VITAL-ECG is a low-cost user-friendly device, which has the size of a watch, comfortable to use for any user (regardless of his/her gender) at wrist.



Fig. 1 Vital-ECG design

A. Device Description

Signal acquisitions are performed without the necessity of precise positioning or calibration. To take under-control the main vital parameters, the use of the wearable device is combined with the use of an Android App, which processes the acquired signals and returns the results: when dangerous situations are recognized (such as atrial fibrillation), an alarm on the app transmits patient information about the current health status. The ECG front-end schematic is shown in Fig. 2. The different blocks acquire independently the vital parameters and transmit the data to the microcontroller,

which stores them into the internal memory and shares them via Bluetooth. This telemedicine approach provides physicians a way to keep patient health under observation.

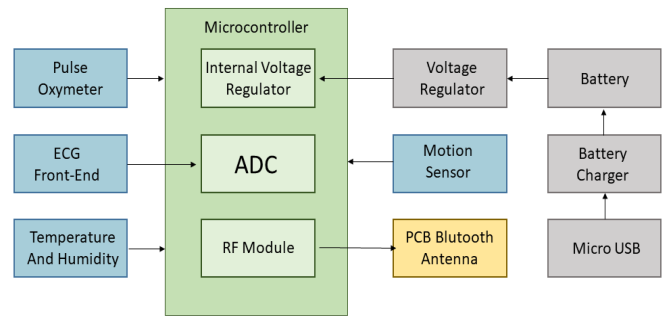

Fig. 2 VITAL-ECG block diagram (device architecture)

B. Comparison with other devices

In this section, a comparative analysis between among wearable devices that monitor cardiac activity is conducted, highlighting the aspects that make the device gender-immune. VITAL-ECG is considered as a gender-immune device because it acquires signals directly from the wrist, without particular positioning. For this reason, it turns out to process data equally in both men's and women's wrists (or ankle). There are several devices that control vital parameters. QardioCore ECG strap is a clinical-quality wearable electrocardiogram recorder [10]. The QardioCore device consists of a belt that wraps around the chest in order to control cardiac activity. However, the device does not appear to be gender-immune since the sensors (which should be placed on the chest) suffer from disturbances in women, due to the presence of the breast. Omron's HeartGuide is a wristwatch that monitors arterial blood pressure. The operating principle is based on swelling and deflation of the strap. Unfortunately, the size of the smartwatch is 'too large' for a woman's wrist, therefore it disadvantages measurement and monitoring of ABP for a woman [11]. Vital-ECG pays close attention to the gender problem, for this reason the device is fair in the acquisition, processing and display of the signals.

C. IoT Paradigm

Vital-ECG has been designed accordingly to the Internet of Things paradigm for smart, wearable healthcare devices for telemedicine and, more generally, mobile health. IoT describes the concept of interconnecting physical devices to the Internet world in a way to build a domain-specific intelligence through seamless sensing, data analytics and information visualization [12]. As shown Fig. 3, Wearable IoT (WIoT) is the technological infrastructure that interconnects VITAL-ECG to Android App platform to enable health monitoring to enhance individuals' everyday quality of life.

WIoT aims at connecting body-worn sensors to the medical infrastructure so that physicians can perform longitudinal assessment of their patients when they are at home.

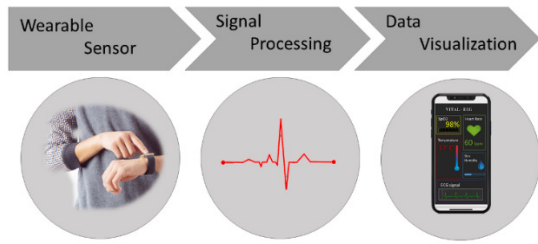

Fig. 3 Architectural Elements of Wearable Internet-of-Things

IV. ML ALGORITHM FAIRNESS

To predict and monitor arterial blood pressure, an artificial neural network is implemented and embedded in the VITAL-ECG. Recently, machine learning techniques have gained a huge popularity in the health field. ML methods are based on the introduction of large amounts of data into the network; however when the data is not balanced the results can be affected by discrimination and they can generate unfairness [13].

A. Artificial neural networks

An artificial neural network is defined as a network composed of a large number of simple processors, called neurons, that are massively interconnected, operate in parallel, and learn from experience [14]. The chosen architecture for the implementation is a multilayer perceptron (MLP) with two hidden layers. Different hidden layer size has been tested to evaluate the corresponding network regression performance to detect ABP values. **Errore. L'origine riferimento non è stata trovata.** shows the optimal architecture, which has 15 and 8 neurons in the first and second hidden layer, respectively.

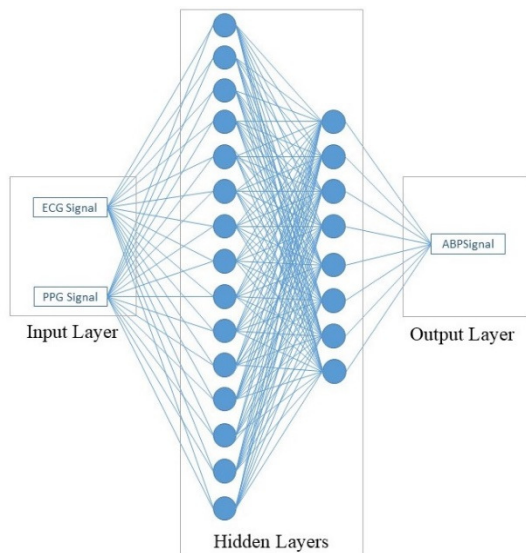

Fig. 4 Artificial Neural Network architecture

The inputs are the entire ECG and PPG recordings extract from MIMIC II Database [15][16]; the output is the blood pressure signal (ABP), synchronized to the two input signals. The hyperbolic tangent was used as transfer function for the hidden layers, while for the output regression layer, the linear

function was chosen. The Levenberg–Marquardt algorithm (LMA) is implemented, which is normally adopted to solve generic curve-fitting problems. This fitting algorithm is quite performing in this kind of task because it finds local minimum; indeed, it can be seen as trade-off technique between the Gauss–Newton algorithm (GNA) and the method of gradient descent [17].

For network implementation, input and target vectors have been randomly divided into three sets as follows: 70% for training set, 15% to validate that the network (validation set) is generalizing and to stop training before overfitting and the remaining 15% is used as a completely independent test for network generalization (test set). Finally, the backpropagation was applied as learning algorithm.

B. Bias Encoded in Data

Often, the data we use for training neural networks includes biases. Heart disease has often been considered a predominantly male problem, underestimating the clinical cases of female patients. This idea can cost the female healthcare. According to a research published in the Journal of Preventive Cardiology, which has examined the opinions of 52 doctors and over 2200 patients [18], mortality has decreased in men since the 1980s because they receive better treatment and more effective secondary prevention after the first CVD acute event. The great attention placed on cardiovascular problems, which concern men, has led over the years to the construction of unbalanced databases, characterized by men's pathologies, paying less attention to the symptoms, treatments and therapies dedicated to women. Of course, machine learning techniques are designed to adapt to data, and so it will be naturally replicate any bias already present in the data. For this reason, a bias mitigation technique will be applied.

C. Bias Mitigation Technique

The de-bias technique is based on AIF360, a new open source tool for algorithmic fairness, designed as an end-to-end workflow. The technique should be able to go from raw data to a fair model as easily as possible [7].

Fig. 5 shows a generic pipeline for bias mitigation.

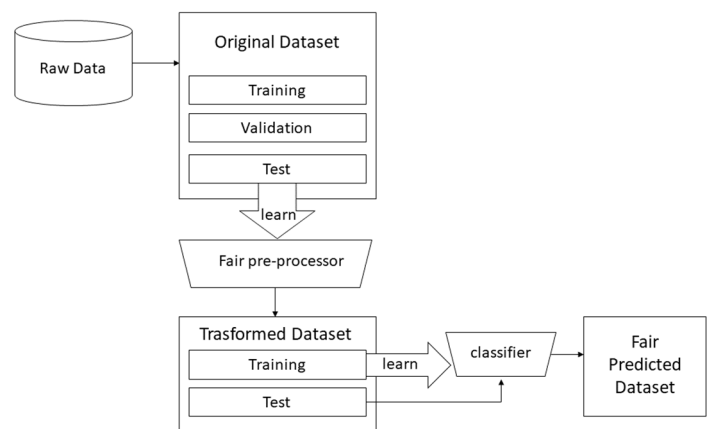

Fig. 5 De-bias technique workflow

Every output in this process is a new dataset that shares, at least, the same protected attributes as other datasets in the

pipeline. Every transition is a transformation that may modify signals between its input and output. Trapezoids represent learned models that can be used to make predictions on test data. The data used to train the ABP algorithm model are unrepresentative and incomplete. Unrepresentative training data is by definition biased. Consequently, the algorithm will malfunction and will not guarantee a correct and fair prediction about individual's health status. Since datasets are data recording from past biased decisions, models trained on this data will simply reflect and reinforce the bias. The cost function was set up to minimize the error between the target and the output. However, the methodology used to train the data leads to bias. Reweighting is a pre-processing algorithm used to mitigate bias prevalent in the MIMIC II training data. The technique recommends generating weights for the training examples in each combination differently to ensure fairness before classification [19]. The idea is to apply appropriate weights to different tuples in the training dataset to make the training dataset discrimination free with respect to the attributes.

V. CONCLUSION AND FUTURE WORK

In this paper, a careful analysis on gender issues has been made. VITAL-ECG is a low-cost, unobtrusive, wearable device that monitors cardiac activity and arterial blood pressure values, in order to ensure a continuous healthcare monitoring. Based on IoT paradigms, VITAL-ECG protects gender equality. This is possible thanks to its comfortable design, which allows detecting, processing and communicating health status through an Android App. The ABP detection is made possible through a machine learning approach (embedded in VITAL-ECG device). Unfortunately, the data used to train the neural network are affected by biases. For this reason, a de-bias technique is implemented to avoid the gender bias and guarantee women a correct reading of their monitoring and diagnosis. Future works will concern the improvement of de-bias techniques, applying fairness solutions also to post-processing data. Finally, the fairness of the system, can be trusted with other de-bias methods.

- [1] S. Hiremath, G. Yang, and K. Mankodiya, "Wearable Internet of Things: Concept, Architectural Components and Promises for Person-Centered Healthcare," in *Proceedings of the 4th International Conference on Wireless Mobile Communication and Healthcare - "Transforming healthcare through innovations in mobile and wireless technologies,"* 2014, doi: 10.4108/icst.mobihealth.2014.257440.
- [2] A. H. E. M. Maas and Y. E. A. Appelman, "Gender differences in coronary heart disease," *Netherlands Heart Journal*, vol. 18, no. 12, Bohn Stafleu van Loghum, pp. 598–603, 2010, doi: 10.1007/s12471-010-0841-y.
- [3] A. Towfighi, L. Zheng, and B. Ovbiagele, "Sex-specific trends in midlife coronary heart disease risk and prevalence," *Arch. Intern. Med.*, vol. 169, no. 19, pp. 1762–1766, Oct. 2009, doi: 10.1001/archinternmed.2009.318.
- [4] "EnterpriseWear Blog - Wearable and Immersive Tech and the Female Workforce." [Online]. Available: <https://www.brainxchange.com/blog/wearable-and-immersive-tech-and-the-female-workforce>. [Accessed: 02-Mar-2020].
- [5] Randazzo, Ferretti, and Pasero, "A Wearable Smart Device to Monitor Multiple Vital Parameters—VITAL ECG," *Electronics*, vol. 9, no. 2, p. 300, Feb. 2020, doi: 10.3390/electronics9020300.
- [6] C. Kumar, V. Sagar, M. Kumar, and K. Kiran, "Awareness about hypertension and its modifiable risk factors among adult population in a rural area of Ranchi district of Jharkhand, India," *Int. J. Community Med. Public Heal.*, vol. 3, no. 5, pp. 1069–1073, Feb. 2016, doi: 10.18203/2394-6040.ijcmph20161359.
- [7] R. K. E. Bellamy *et al.*, "AI Fairness 360: An Extensible Toolkit for Detecting, Understanding, and Mitigating Unwanted Algorithmic Bias," *IBM J. Res. Dev.*, vol. 63, no. 4–5, Oct. 2018.
- [8] "Gender." [Online]. Available: <https://www.who.int/health-topics/gender>. [Accessed: 02-Mar-2020].
- [9] V. Randazzo, E. Pasero, and S. Navaretti, "VITAL-ECG: A portable wearable hospital," in *2018 IEEE Sensors Applications Symposium, SAS 2018 - Proceedings*, 2018, vol. 2018-January, pp. 1–6, doi: 10.1109/SAS.2018.8336776.
- [10] "A Review Of The QardioCore ECG Strap From A Patient's Perspective - The Skeptical Cardiologist." [Online]. Available: <https://theskepticalcardiologist.com/2018/09/30/a-review-of-the-qardio-core-ecg-strap-from-a-patients-perspective/>. [Accessed: 03-Mar-2020].
- [11] "Hands On: Omron's HeartGuide Wearable Blood Pressure Monitor | PCMag." [Online]. Available: <https://www.pcmag.com/news/hands-on-omrons-heartguide-wearable-blood-pressure-monitor>. [Accessed: 03-Mar-2020].
- [12] J. Gubbi, R. Buyya, S. Marusic, and M. Palaniswami, "Future Generation Computer Systems Internet of Things (IoT): A vision, architectural elements, and future directions," *Futur. Gener. Comput. Syst.*, vol. 29, pp. 1645–1660, 2013, doi: 10.1016/j.future.2013.01.010.
- [13] A. Chouldechova and A. Roth, "The Frontiers of Fairness in Machine Learning," Oct. 2018.
- [14] D. F. Specht, "Brief Papers A General Regression Neural Network."
- [15] G. B. Moody and R. G. Mark, "A database to support development and evaluation of intelligent intensive care monitoring," *Comput. Cardiol.*, vol. 0, no. 0, pp. 657–660, 1996, doi: 10.1109/cic.1996.542622.
- [16] A. L. Goldberger *et al.*, "PhysioBank, PhysioToolkit, and PhysioNet: components of a new research resource for complex physiologic signals.," *Circulation*, vol. 101, no. 23, 2000, doi: 10.1161/01.cir.101.23.e215.
- [17] K. Fujii, "Least Squares Method from the View Point of Deep Learning II: Generalization," *Adv. Pure Math.*, vol. 08, no. 09, pp. 782–791, 2018, doi: 10.4236/apm.2018.89048.
- [18] K. Allesøe, K. Sogaard, M. Aadahl, E. Boyle, and A. Holtermann, "Are hypertensive women at additional risk of ischaemic heart disease from physically demanding work?," *Eur. J. Prev. Cardiol.*, vol. 23, no. 10, pp. 1054–61, Jul. 2016, doi: 10.1177/20474873166631681.
- [19] M. Ren, W. Zeng, B. Yang, and R. Urtasun, "Learning to Reweight Examples for Robust Deep Learning," *35th Int. Conf. Mach. Learn. ICML 2018*, vol. 10, pp. 6900–6909, Mar. 2018.