

A Critical Review on the Structural Health Monitoring Methods of the Composite Wind Turbine Blades

*Original*

A Critical Review on the Structural Health Monitoring Methods of the Composite Wind Turbine Blades / Malekimoghadam, Reza; Krause, Stefan; Czichon, Steffen. - ELETTRONICO. - (2021). (Intervento presentato al convegno 1st International Conference on Structural Damage Modelling and Assessment, SDMA 2020 tenutosi a Ghent nel 4 August 2020through 5 August 2020) [10.1007/978-981-15-9121-1\_29].

*Availability:*

This version is available at: 11583/2848110 since: 2020-10-30T13:17:13Z

*Publisher:*

Springer Singapore

*Published*

DOI:10.1007/978-981-15-9121-1\_29

*Terms of use:*

This article is made available under terms and conditions as specified in the corresponding bibliographic description in the repository

*Publisher copyright*

(Article begins on next page)

# A Critical Review on the Structural Health Monitoring Methods of the Composite Wind Turbine Blades

Reza Malekimoghadam <sup>1</sup>, Stefan Krause <sup>2</sup> and Steffen Czichon <sup>2</sup>

<sup>1</sup> Department of Mechanical and Aerospace Engineering, Politecnico di Torino, Corso Duca degli Abruzzi 24, 10129 Torino, Italy  
reza.malekimoghadam@polito.it

<sup>2</sup> Fraunhofer Institute for Wind Energy Systems IWES, Bremerhaven, Germany

**Abstract.** With increasing turbine size, monitoring of blades becomes increasingly important, in order to prevent catastrophic damages and unnecessary maintenance, minimize the downtime and labor cost and improving the safety issues and reliability. The present work provides a review and classification of various structural health monitoring (SHM) methods as strain measurement utilizing optical fiber sensors and Fiber Bragg Gratings (FBG's), active/ passive acoustic emission method, vibration-based method, thermal imaging method and ultrasonic methods, based on the recent investigations and promising novel techniques. Since accuracy, comprehensiveness and cost-effectiveness are the fundamental parameters in selecting the SHM method, a systematically summarized investigation encompassing methods capabilities/ limitations and sensors types, is needed. Furthermore, the damages which are included in the present work are fiber breakage, matrix cracking, delamination, fiber debonding, crack opening at leading/ trailing edge and ice accretion. Taking into account the types of the sensors relevant to different SHM methods, the advantages/ capabilities and disadvantages/ limitations of represented methods are nominated and analyzed.

**Keywords:** Structural health monitoring, Wind turbine blades, Sensors, Damage detecting.

## 1 Introduction

Wind energy as one of the fastest growing renewable energy resources, imparts a significant contribution in the energy market. In accordance with the information supplied, it is appraised that the wind power will provide 12% and 20% of electricity power by 2020 and 2030, respectively [1, 2]. In order to decrease levelized cost of energy (LCoE), reduction of the operations and maintenance cost is an urgently required [3]. Apart from optimizing the design of turbines to ameliorate the availability, another feasible way is exerting reliable and cost-effective condition monitoring system (CMS).

Preventing unexpected catastrophic failures and diminishing unscheduled maintenance, are the prominent purposes that have appeal for employing next generation of

wind turbines. Thus, Structural Health Monitoring systems (SHM) can extraordinarily impart reliability and profitability to wind turbines due to detecting the defects at incipient step during operation or testing procedures [4]. Sensing process and the interpretation algorithm are considered as the two crucial parameters which impress SHM growth and development [5, 6]. It should be notified that the blades are considered as one of the most significant components in the turbines [7], since the performance of WT is remarkably dependent on the blades. Furthermore, the blade manufacturing expense is about 15% to 20% of each wind turbine [8]. Significantly, longer blades are being designed, in order to sweep larger area. Hence, carbon fiber reinforced polymer (CFRP) is increasingly being utilized for very large blades. However, the bigger size of wind turbine blade (WTB) leads to increase the load levels [9].

Therefore, for sake of eliminating unexpected maintenance, vital failures and minimizing downtime, the wind turbines must be continuously monitored to assure their perfect and appropriate conditions [10]. The situation of health monitoring systems and evaluation techniques for offshore wind turbines (OWTs) were reviewed by Lian et. al [11], considering supervisory control and data acquisition (SCADA) systems and condition monitoring (CMS) as the most conventional types of health monitoring systems of the OWT.

In accordance with Farrar and Sohn [12], SHM represents the procedure of implementing a damage detection strategy for engineering infrastructures related to aerospace, civil and mechanical engineering, being damage referring to the variations in material and/or geometric properties of these systems. Likewise, some of the most known causes of structural damages are fatigue, wind gusts, moisture absorption [13], thermal stress, corrosion [14], fire and lightning strikes [15]. Moreover, a SHM could be efficient regarding two issues including the fatigue issue and utilization of lighter blade which the former could be useful due to difficulty of predicting the exact life of a wind turbine components, whereas the latter yield higher performance of the wind turbines [16]. Considerably, the advantages of possessing a damage detection system can be classified as an impediment of premature breakdown, reduced maintenance cost, supervision at remote sides and remote diagnosis, improvement of capacity factor and support for further development of a turbine [17]. Schubel et. al [18] presented a review of structural health monitoring methods, encompassing residual cure strain monitoring for the wind turbine blade industry in conjunction with a comparison between different monitoring methods. Thus, a SHM system is required to frequently monitor the condition of the wind turbine blades and warning the failures at incipient level.

Consequently, the present work furnishes a review and classification considering different damage types and employed sensors in different SHM methods which have been presented in the recent investigations and upcoming promising techniques in both industrial and academic sections; subsequently corresponding pros and cons are introduced.

## 2 Blade Structural Damages

The damages can occur in any part of the wind turbine while the most prevalent type of damage happens in the blade and tower [19]. Since the blade is the significant part of the wind turbine and its price is about 15% to 20% of the total cost of the turbine, therefore, tremendous attention has been received by structural health of the blades [20]. In addition, it has been demonstrated that the damage occurred in the blade, is the most expensive type of damage with the longest time for repairing [20]. Likewise, occurring the damage in the blade leads to unbalanced condition of the blade during its rotation which result in secondary failure of wind turbine by collapsing the tower, as well as blade failure [21]. Thus, the present work concentrates on the damages occurring in the rotor blade of the wind turbine. In order to realize the blade damage, the main segments of a blade should be known previously, which are depicted in Fig.1.

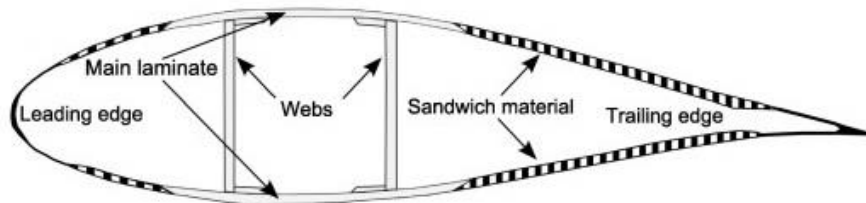
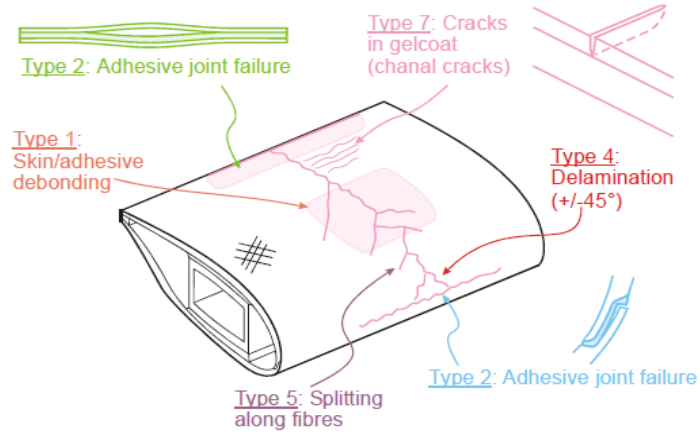

Fig. 1. Sketch of cross-section of a wind turbine blade [22]

The materials of the conventional blades are often glass/ carbon fiber-reinforced composites [23], whereas by increasing the size of the blade nowadays, the utilization of carbon-fiber reinforced composites has recently been augmented in order to fabricate the turbine blades. Regarding the blade structure, there is a main spar tube, and the upwind side and downwind side of the blade are constructed and joined at both the leading edge and the trailing edge using adhesive. Blade damages can occur in different ways which typical damages in the wind turbine blades are represented in Table.1 [24, 25] and schematic illustrations of corresponding damages are delineated in Fig.2.



**Fig. 2.** Types of damage withstood by the wind turbine blade

Below the corresponding damages types in a wind turbine blade are illustrated in accordance with Fig.2.

**Table 1.** Typical damages of wind turbine blades [10,24,25]

<b>Damages Types</b>	<b>Descriptions</b>
Damage Type 1	Damage formation/ growth and debonding in the adhesive layer joining skin and main spar flanges
Damage Type 2	Damage formation and growth in the adhesive layer joining the top and down skins along leading or trailing edges
Damage Type 3	Damage formation/ growth at the interface between face and core in sandwich panels in skins and main spar web
Damage Type 4	Internal damage formation/ growth and delamination in laminates in skin or the main spar flanges
Damage Type 5	Splitting and fracture of separate fibers in laminates of the blade structure and main spar
Damage Type 6	Buckling of the skin due to damage formation and growth in the bond between skin and main spar under compressive load
Damage Type 7	Debonding of the gelcoat from the blade surface (gel-coat cracking and gelcoat/skin debonding)

A report concerning the identification of different types of damage that developed for Vestas A/S V52 wind turbine blade, tested to failure under quasi-static loading, were provided by Sørensen et al. [22]. Some of the occurred blade failures during the laboratory tests are described in Fig.3.

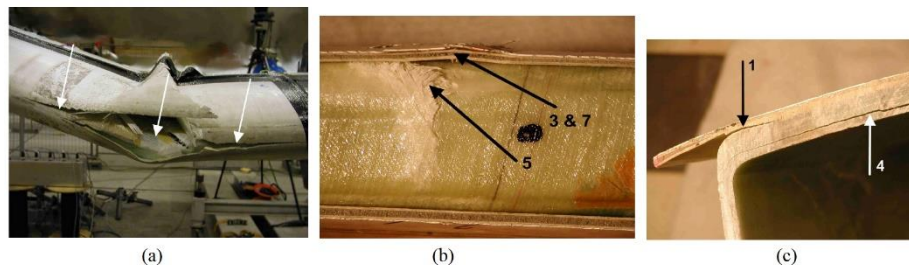

**Fig. 3.** (a) Adhesive joint failure between skins at the leading edge (Damage type 2), (b) sandwich panel face/core debonding ( Damage types 3 ), laminate failure in compression (Damage types 5) and gel-coat/skin debonding (Damage types 7), (c) Debonding of the main spar flange (Damage type 1) & delamination in the laminated structure (Damage type 4) [22]

### 3 Structural Health Monitoring Methods (SHM)

In this chapter, a review of recent investigations and novel promising techniques is presented. While it is difficult to provide a quantitative comparison between methods, advantages and drawbacks of methods are discussed.

#### 3.1 Acoustic Emission Method

The Acoustic emission (AE) phenomenon is based on the release of energy in the form of transitory elastic waves within a material having a dynamic deformation process [26]. Damages such as crack growth, debonding, large deformation, delamination and impacts can stimulate transient alteration in the elastic energy in specific position of a structure which are detected by acoustic emission method. Likewise, AE is capable of detecting the fault and malfunction in gearboxes, bearings, shafts of the wind turbines [27].

The common AE parameters which are measured during the tests include amplitude, root mean square (RMS) value, energy, counts, and events [28]. Regarding the sensor types, piezoelectric transducers and optical fiber sensors are utilized in AE technique. The signal attenuation should be considered rigorously as a significant limitation of this method. Therefore, the sensors which are employed in AE method must be positioned as close as possible to the damage source [28], which causes an important limitation in exerting AE method in wind turbines. Although the acoustic emission method is based on fast release of localized energy in form of elastic wave in material, the damage process and stress waves also emit airborne sound where the latter doesn't suffer from signal attenuation phenomenon [29]. By analyzing the sensors attenuation, Van Dam et al. [30] demonstrated that the sensors distance should be limited to a maximum of 1 m.

It is noteworthy to mention that the propagation of the acoustic emission waves is influenced by damage inside the material, and Fiber Bragg gratings (FBGs) can be utilized to detect the strain alterations of Lamb waves. Hence, FBGs, with their small

diameter, exhibit remarkable performance as Lamb wave sensors for damage detection and debonding in composite structures [31].

The pertinent standards to this method are ‘ASTM E2374- 15: Standard Guide for Acoustic Emission System Performance Verification’ and ‘ASTM E976: Standard Guide for Determining the Reproducibility of Acoustic Emission Sensor Response’, (pencil-lead breakage test). On the other hand, the high accuracy, the higher number of sensors are required which engender to increase the amount of output data for signal processing. Thus, owing to diminish the number of output data, Schulz et al. [32] proposed a structural neural system (SNS) for SHM which possesses several input channels from the sensors and two output channels, reducing the quantity of data acquisition channels for SHM. Utilizing AE method, a turbine blade with length of 45.7 m was tested under fatigue loading by Tang et al. [33], employing piezoelectric sensors, as described in the Fig. 4.

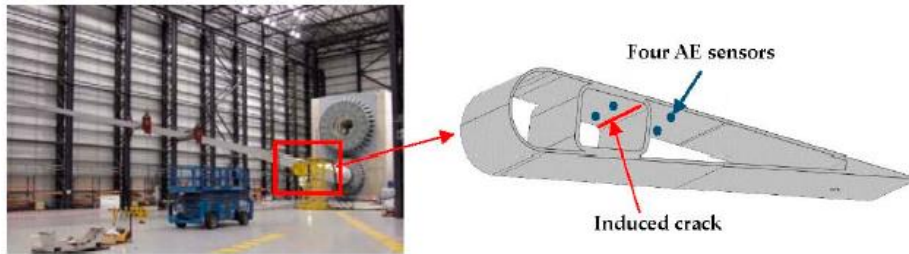

**Fig. 4.** Testing the turbine blade and AE sensors mounted on the internal side of the blade.

Foregoing research was conducted different damage mechanisms through frequency-based methodologies [34–37]. Summarized results are listed in Table 2.

**Table 2.** Frequency analysis outcomes for different damages [34-37]

Damages Types	Range of Frequency (kHz)			
	Glass-Polyester [36]	Glass-Polypropylene [37]	Carbon-Epoxy [34]	Carbon-Epoxy [35]
Matrix cracking	30–150	-	<100	0–50
Delamination	-	-	-	50–150
Debonding	180–290	100	200–300	200–300
Fiber breakage	300–400	450–550	400–450	400–500
Fiber pull out	180–290	200–300	-	500–600

Muñoz and Márquez [38] proposed to detect and locate cracks on the surface of the blades employing three macro-fiber composite (MFC) sensors [39] in a section of a wind turbine blade. The results demonstrated that by employing the three low cost sensors, a fiber breakage occurred in a blade can be detected and located appropriately. The graphical approach of triangulation was applied for the signal processing. The

method was capable of detecting the position of the acoustic emission with high accuracy with the maximum error of 9 mm.

A laboratory study was reported by Tang et. al [40] regarding fatigue damage growth monitoring through AE in a complete 45.7 m long wind turbine blade. Using compact resonant masses (CRM), the blade was excited for 187,000 fatigue cycles, during which AE monitoring was performed with a 4-sensor array. The CRMs were exerted in order to generate the crack and to simulate the blade vibration. The full-length blade and the CRMs are displayed in Fig. 5.

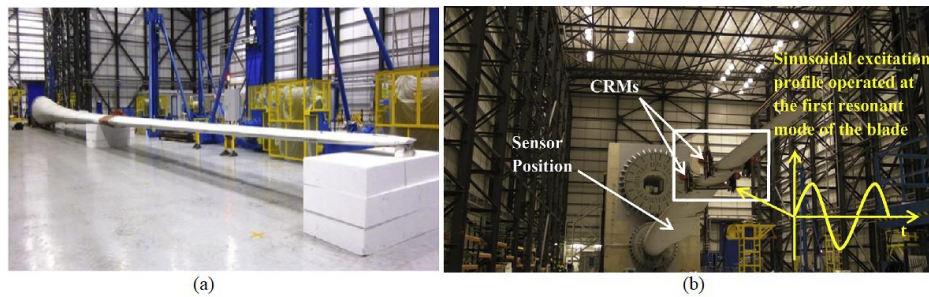

**Fig. 5.** (a) Wind turbine blade under test (b) CRM installed on the wind turbine blade [40]

According to frequency content of AE signals, three failure modes encompassing fiber failure (300 kHz), fiber-matrix debonding (250 kHz) and matrix cracking (110 kHz) were distinguished. Moreover, a vibration test of the blade was implemented before conducting the fatigue test. After about 67,000 fatigue cycles, a crack with dimensions of 0.2 m x 0.05 m x 0.01 m was intentionally introduced in one of the shear webs and the four sensors were positioned in the foregoing zone internally [40]. Significantly, the results revealed that after the introduction of the defect, there is no visible difference in the modal frequencies, highlighting that these modes are not proper for detecting damages by monitoring of the mode frequency shift which can be seen in Fig.6(b).

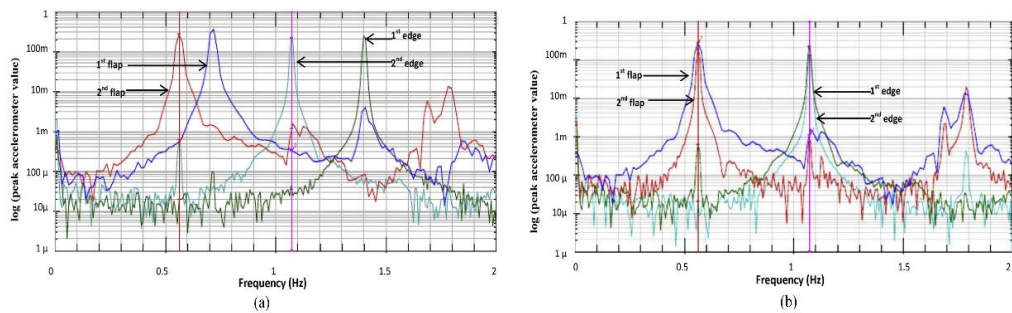

**Fig. 6.** (a) Frequency shifts after adding mass (b) Frequency spectrums after applying of a 0.2 m defect [40].



In accordance with calculations, one sensor is capable of monitoring with the range of 0.8 m in all directions. Based on the range of the AE signals as an important parameter, 28 sensors could prepare basic monitoring for a 45m blade. Notably, with changing the threshold, the sensor range could be varied leads to changes in number of the sensors [40].

Audio-level acoustics-based damage detection approach as a non-traditional technique has received little attention up to now, which is based on passively generated acoustic signals, such as noise of cracking, debonding, etc. [28, 41-43].

Utilizing the airborne sound proposed by Krause and Ostermann [43], the damage detection procedure of a 34-m blade was carried out employing three optical microphones. The optical microphones were mounted inside the blade which are depicted in Fig. 7. The microphones were installed orthogonal on the blade spars and all the microphones were considered as omnidirectional.

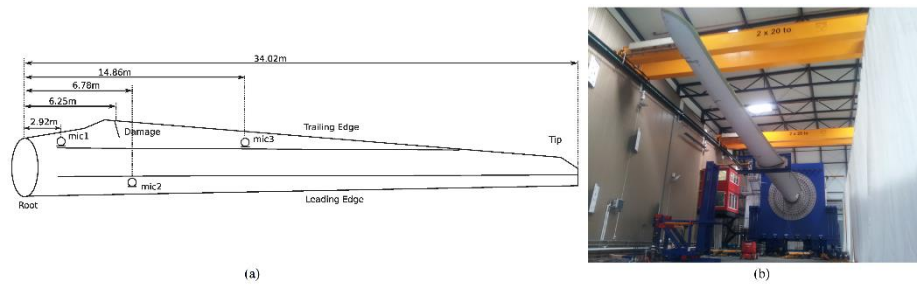

**Fig. 7.** (a) Drawing of the blade indicating the positions of microphones and damage (b) Blade fatigue test implemented at Fraunhofer Institute for Wind Energy and Energy System Technology [43]

The characteristics of audible cracking sounds were computed for all microphone signals. According to the abovementioned research, it is difficult to validate this method generally, but nonetheless, the estimation exhibits good correlation with the size of damages after visual inspections [43]. Markedly, providing reliable data of blade damage detection using airborne sound method includes several uncertainties which requires further investigations and conducting experimental tests under different operational conditions [43]. Likewise, this method is highly dependent on the environment and background noises which could be considered as one of the limitations of the mentioned technique.

The other significant type of acoustics-based method utilizes the acoustic signatures which are actively generated by an acoustic speaker, for sake of detecting damage, abating the inherent limitations of passive-based techniques by representing flexibility regarding the procedure and duration of structure excitation [44]. The active acoustic damage detection approach, schematically represented in Fig.8 for a wind turbine blade, damage, speakers and microphones, in which the acoustic energy transmitted from the internal cavities of the structure to its exterior [45].

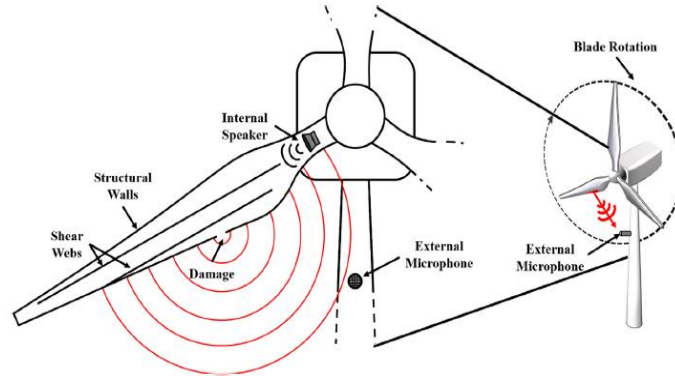

**Fig. 8.** Schematic illustration of the active acoustic damage detection method [45]

The acoustic signal alterations during transmitting through boundaries of structural cavities is investigated by Beale et al. [46] as a novel damage detection method. Focusing on active acoustic emission method, the damage was detected by measuring the acoustic pressure responses externally whereas the structure is subjected to internal acoustic excitations. The method was employed for damage detection of 46 m wind turbine blade considering various types of damage and different severity and locations. Extraordinarily, due to the low attenuation of sound in air, very few or even a single microphone could be sparsely located on the tower for capturing the excitation signals [46]. Moreover, minimum acoustic signal is transmitted through undamaged blade whereas a damaged blade allows high acoustic signal to be transmitted due to sound leakage from a damage position on the blade.

Fig.9 describes two configurations of experimental set up, consisting of microphone and speaker positions.

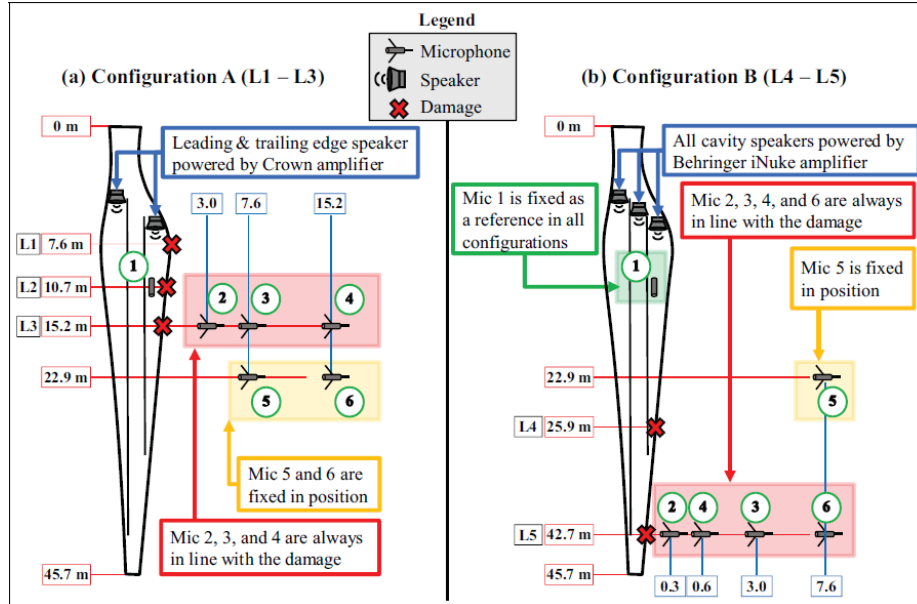

**Fig. 9.** Schematic of 46 m wind turbine blade, with the positions of the microphone and speaker representing the active acoustic emission method [46]

The results divulged that damages as small as 5.1 cm introduced before the mid-length of the blade were conveniently captured by different sensors ranging between 3 and 17.1 m from the damage position. It is worth mentioning that the active-based method should be limited for detecting edge splits, cracks, holes, and damage types that extend through the entire skin of the structure.

In addition to available academic researches, various commercial SHM systems are available on the market. Based on damage sound detection, a damage detection system has recently been represented by Ping Services company [47]. As their algorithms are mostly proprietary, the commercial methods are not discussed further.

### 3.2 Thermal Imaging Method

Thermal imaging method is a detection technique for subsurface defects or abnormalities exerting temperature differences observed on the assessed surface by employing infrared sensors or cameras [48]. So, damages occurred in the structures are detectable due to a change in the thermal diffusivity [49]. Based on thermal excitation method, the thermal imaging is classified as passive or active methods. The passive type is exerted to assess structures that are at a different temperature than ambient [50]. The active approach possesses an external stimulus source such as optical flash lamps, or heat lamps. The passive method is not usual in wind turbine SHM during the tests and more improvements are needed to be flourished as a promising method. Thermoelastic stress method as a specific type of active thermal imaging method, is based on the thermoelastic effect, in which the stress alterations in the materials will cause the

change in temperature [50]. This technique has been demonstrated as an efficient approach for fatigue tests of wind turbine blades [51], since stress concentrations could be captured during the test before extension of damage on the surface

A fatigue test of the 13.4m sectional blade was accomplished by means of a thermoelastic stress analysis camera (TSA), in order to observe the stress distributions [52]. The detected areas of stress concentration had not previously been predicted by the finite element method. Hence, at those damage-prone locations more strain sensors were exerted. Thus, measuring the strains could be useful to calibrate the signals exhibited by the TSA camera. Fig. 10 illustrates the finite element analysis and the blade structure during the test conditions.

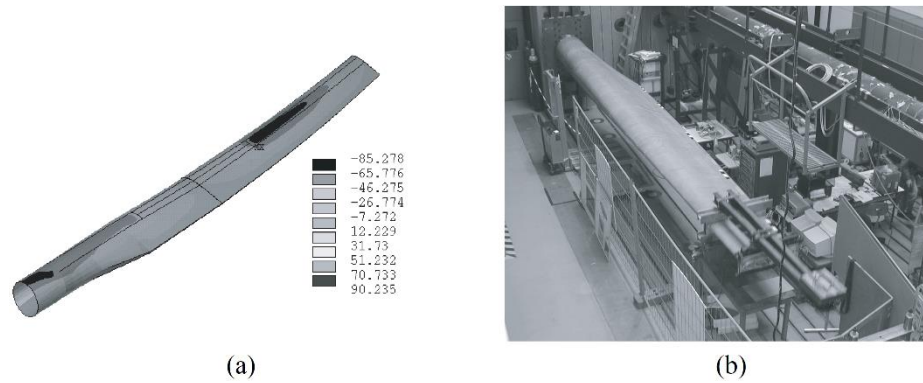

**Fig.10.** (a) Finite element results (strains in lengthwise direction), (b) Blade structure during test [52]

Regarding the composite structures, a suggested relationship can be expressed as following [52]:

$$\Delta T = \frac{-T}{\rho C_p} (L \Delta \sigma_{11} + M \Delta \sigma_{22}) \quad (1)$$

Which is proper for observation at a surface, thus  $\Delta \sigma_{33}$  is excluded because it is necessarily zero and the directions of 11 and 22 imply on the principal directions of the laminate. The parameters L, M must be obtained from measurement [52].

Furthermore, as well as blade damage detection, thermal imaging method is capable of diagnostic and monitoring in a broad range of applications in components such as bearings, gear boxes, electric generators, etc. However, due to slow spread of temperature inside the material, it is not an appropriate method for early damage detection [53, 54].

The vibro-thermographic technique, as a promising branch of thermal imaging, is able to detect the crack, damage, voids and stress concentrations utilizing high power ultrasounds [55], or oscillating stresses with a mechanical shaker [56]. Therefore, this method could prosper as a promising SHM method for wind turbines, while more investigations are required in order to diminish the sensitivity to temperature altera-

tions [51]. More assessments are needed for the application of thermal imaging method to in-service WT's due to its sensitivity to ephemeral temperature alterations [51]. In addition, thermal imaging method is capable of producing a full-field measurement in image form which provides a rapid evaluation possible even for a non-professional operator. However, the cardinal problem of the thermal imaging technique is the thermal excitation procedure. Regarding the passive type, the environmental conditions (such as cloud cover, solar radiation, wind speed) play a crucial role on the outdoor infrared thermographic surveys. On the other hand, regarding the active excitation, it is not cost-effective and efficient to excite the turbine on site [10]. Regarding the thermoelastic stress excitation method, its shortcoming is the necessity to apply load cyclically, which can lead to damage growth during defining the existing damage [57]. As a specific technique, non-contact ultrasound-induced thermography could be a promising technology for using in SHM of wind turbines, as in aircrafts [58]. As other drawbacks of thermal imaging method, detecting the cracks depends on camera resolution and it is impossible to penetrate in extended depths of the structures. Eventually, it can be concluded that this method could be utilized as a complementary method to other monitoring techniques for acquiring a comprehensive and accurate damage detection.

### 3.3 Ultrasonic methods

Ultrasonic method is a technique commonly employed for investigating the inside of structures [59] which is based on propagation and reflection of elastic wave within the material. The basic principle of the technique is that an ultrasonic wave is passed through the material and is then reflected and/or mode converted by a defect. Three different techniques can be taken into account for this method as pulse-echo, through transmission, and pitch-catch [60, 61]. This technique is capable of detecting planar cracks that occur perpendicularly to the direction of wave propagation. This technique is widely employed by the wind energy industry for structural assessment of towers and blades [62].

This method provides an evaluation of the location and nature of the damage through wave propagation which can be used for SHM and determination of material properties of WT components [63]. In addition, ultrasound scanning can be exerted to observe the beneath surface and delamination in composite structures [64]. The transit time and amplitude can be exploited for defining the position and the severity of the damage [25]. Moreover, ultrasonic could be used for inspection of adhesively bonded parts in the composite structures for detecting of delamination and interlaminar weakness [65]. Furthermore, employing a scanning sensing laser beam, ultrasonic images can be constructed by utilizing the ultrasonic excitation at a specific point while measuring corresponding ultrasonic responses from multiple points [8]. Lee et al. [66] propose a portable long-distance ultrasonic propagation imaging (LUPI) system that uses a laser beam targeting and scanning system to excite, from a long distance, while acoustic emission sensors are installed in the blade. It was proposed to a portable health monitoring system for in situ long distance applications in wind turbine blade. The feasibility of the introduced method was verified on a 2 MW commercial wind

turbine system. The embedded AE sensors at various damage hot spots acted as the ultrasonic sensors during the damage evaluation and visualization process, as well as the sensing component for damage localization. A schematic diagram of the entire Portable ultrasonic propagation imaging (UPI) system configuration is shown in Fig. 11(a). Fig. 11(b) and (c) represent the configuration and installation of a portable long-distance ultrasonic propagation imaging (LUPI) laser targeting and scanning system in a turbine tower.

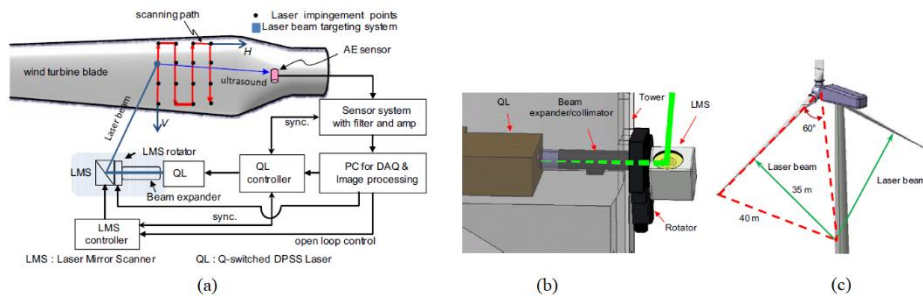

**Fig. 11.** (a) Portable UPI system configuration for long distance application (b) System configuration and installation of long-distance laser excitation system (c) Parked turbine blades at optimal position for scanning [66]

A study of complete noncontact laser ultrasonic wavefield imaging technique was proposed by Park et al. [67], to automatically detect and visualize hidden delamination and debonding in composite structures. A blade of 10 kW wind turbine was provided for testing, depicted in Fig. 12(a). The blade possesses the dimensions of 3500 mm×500 mm×3 mm made of GFRP materials, which comprises 6 plies. Owing to simulate the internal delamination, a 15 mm diameter Teflon tape was embedded between the plies during manufacturing process. Fig. 12(b) and (c) compares cumulative total wave energy (CTWE) and cumulative standing wave energy (CSWE) images acquired from the scanning region of the blade. In CSWE image, the incident wave energy and other noise components were eliminated, and only the location of delamination was displayed.

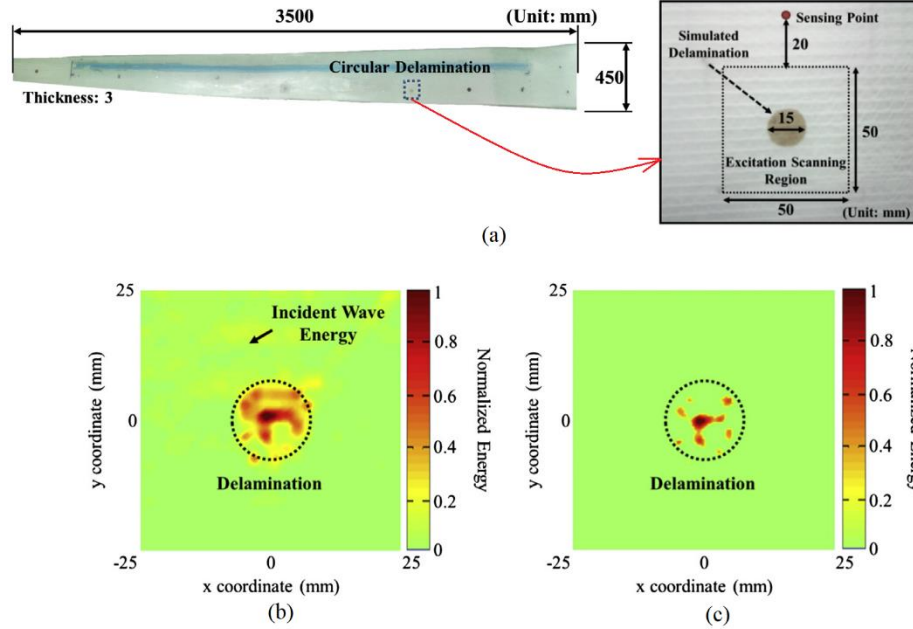

**Fig. 12.** (a) composite blade of wind turbine, (b) CTWE image, and (c) CSWE image [67]

The introduced technique possesses following advantages: (1) it does not require any sensor installation; (2) it is noninvasive, rapidly deployable and applicable to harsh environments; and (3) it can visualize damage with high spatial resolution without any baseline data, which enables automated and intuitive damage diagnosis [67].

Ultrasound methods can be exerted for other purposes, such as measuring the thickness of the parts as well as crack detection. However, ultrasound techniques are insensitive to single fiber break in composite structures. [10]. As a remarkable limitation, planar defects parallel to the wave propagation may not be detected. Moreover, this method has problem of monitoring irregular, rough, thin, or non-homogeneous materials.

### 3.4 Strain measurement method

Strain monitoring is a method for capturing microscopic length changes in a component [4] and the length variations directly correlate to stresses generated in the structure [18]. Markedly, strain sensors must be located at specific positions, where large deformations are anticipated which restrict their applicability for damage detection in a structure [26]. To this end, prior knowledge of the stress field of structure such as employing finite element analysis is required, thus, the sensors should be installed in vital locations.

Multifarious sensors are exploited in strain measurement method as traditional electrical sensors (e.g., piezoelectric materials, capacitance, inductance, etc.), fiberoptic sensors and recently the most popular types of sensors namely, Fiber Bragg

Grating (FBG) sensors. Some main drawbacks of the electrical sensors are presented as below [18, 68]:

1. Influence of temperature on the performance of the piezoelectric sensors
2. Non-linearity
3. Hysteresis and zero shift due to cold work
4. Weakening of the signal over a considerable distance

Fiber-optics sensors can be mounted on the wind turbine blades for load measurement. By applying the strain on the component, the power of the light source will reduce which enables measurement of the applied load [69]. As a simplest sensing principle, the light power dwindles linearly with increasing of the strain, while decreases tremendously when the crack appears in the structure [69]. Some of the advantages of optical fiber sensors can be indicated as higher fatigue resistance, eliminating the wiring issues, and monitoring more locations with the same cable.

Fiber Bragg gratings (FBGs), as wavelength-based sensors, are made by illuminating the core of a suitable optical fiber with a spatially-varying pattern of intense ultra-violet (UV) laser light [70].

The advantages of FBG's are expressed as following:

1. Minimal size, high strength, very sensitive
2. Lightning safety and neutrality to Electromagnetic interference (EMI)
3. Capability of measuring various parameters such as strain, temperature, sounds, pressure, accelerometer, etc.
4. Multiplexing: ability to engrave several sensors on a single fiber; for an instance, temperature and strain can be measured with the same sensor
5. Combining multiple gratings in a single fiber: reading simultaneously large numbers of sensors on a very few fibers, leading to reduced cabling requirements and easier installation

The Bragg wavelength,  $\lambda_B$  is determined by the below expression [71]:

$$\lambda_B = 2n_{eff}\Lambda \quad (2)$$

where  $n_{eff}$  indicates the effective refractive index and  $\Lambda$  the grating pitch.

As the measuring procedure, by applying the strain and altering the mechanical or physical of grating region,  $\Lambda$  and  $n_{eff}$  will be changed and consequently the reflected wavelength ( $\lambda_B$ ) will be influenced accordingly, therefore, it can be utilized to measure the applied loads [72]. A schematic illustration of FBG response during imposed strain and its working principle are depicted in Fig.13.



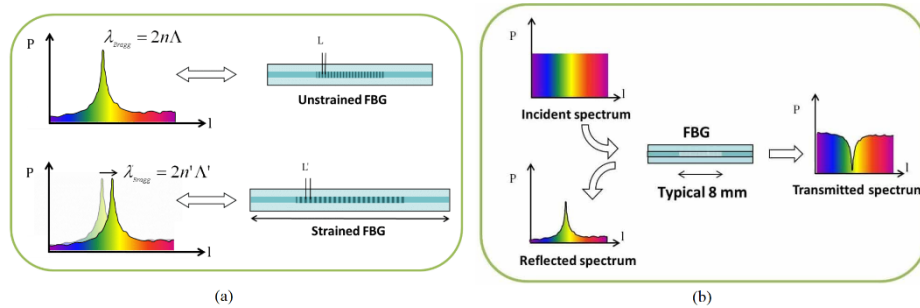

**Fig. 13.** (a) FBG response as function of strain, (b) Working principle of FBG [73]

An FBG measurement system for strain monitoring in WT blade with length of 45 m, has been mounted and demonstrated by Schroeder et al. [74]. In order to conduct the experiment, three strain sensor pads each have been attached to both the windward and the leeward internal surfaces of the blade, on opposite symmetrical positions which can be seen in Fig. 14.

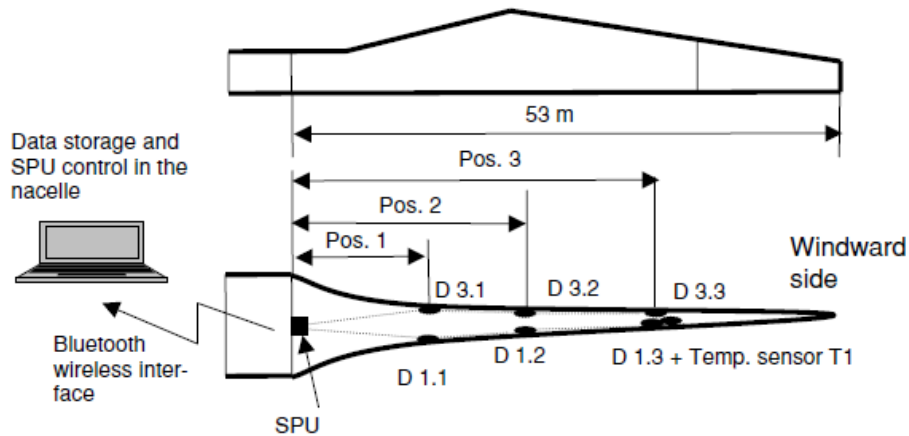

**Fig. 14.** Scheme of the positions of sensor pads and signal-processing unit (SPU) in the blade [74]

For sake of obtaining the averaged load transfer from the blade to the relatively short FBG strain sensor, a very long sensor pad with length of 400 mm was selected, in comparison with the FBG sensor length of 5 mm. Finally, the average strain over the pad length of 400 mm was calculated. The photo of the six sensor pads is exhibited in Fig. 15, emphasizing that the third pad comprises a temperature sensor.

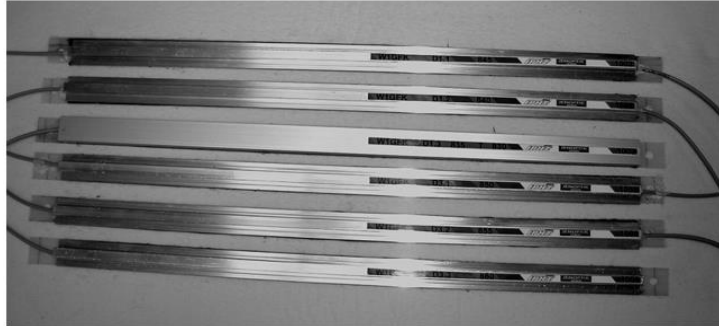

**Fig. 15.** The sensor pads for strain monitoring in the WT blade [74]

FOS4X sensor technology [75], employs fiber-optical strain and accelerometer sensors based on Fiber Bragg grating sensor (FBG) for structural health monitoring of wind turbine blades.

FIBERSAIL [76] is a shape sensing system based on FBG fiber optic sensors to monitor and analyze windmill blades in terms of shape, condition, and behavior.

As another strain measurement approach, Moog Insensys [77, 78] has designed a new system for monitoring the blade pitch angle and for measuring the mass increase of the blades due to ice accretion, employing fiber optic strain sensors.

### 3.5 Vibration-based method

The vibration-based methods are among the most significant SHM methods for OWT [79, 83]. The method is based on the fact that modal parameters such as frequencies, mode shapes and modal damping, are functions of the physical properties of the structure such as mass, damping and stiffness. Therefore, changes in the physical properties, such as reductions in stiffness originating from the onset of cracks or loosening of a connection, will engender detectable changes in the modal properties [84]. Moreover, the damage detection relies on a comparison between the dynamic response of the structure condition before and after occurring damage. So, changes in modal features, could be utilized as damage indicators [85, 86]. Owing to investigate the dynamic response of the structure by studying the mode shapes, several accelerometers must be mounted [87]. In order to compare the resonant frequency, Ghoshal et al. [88] investigated the application of PZT patches at hot spots. The damage can be detected by measuring the differences in the resonance responses of the healthy and damaged structure.

As another damage detection approach based on vibration methods called Impedance-based damage detection method, various investigations were studied [89, 90]. In this method, by appearing damages in the structure, the electrical impedance of piezoelectric materials will be changed and monitored subsequently.

Pitchford et al. [90], employed foregoing method to detect damage on a wind turbine blade. The technique utilizes small piezoceramic (PZT) patches attached to a structure as self-sensing actuators to both excite the structure with high frequency

excitations and monitor any changes in structural mechanical impedance. By monitoring the electrical impedance of the PZT, assessments can be made about the integrity of the mechanical structure. Their outcomes demonstrated that impedance based SHM is capable of detecting damage on the blade section and it is a promising technique for exerting in WT blades.

On the other hand, conducting accurate analyses on a full-scale offshore wind turbine (OWT) during operational condition is tremendously troublesome due to the high number of uncertainties induced by offshore environment such as wind and wave loading. Due to mentioned limitations, Operational Modal Analysis (OMA) is employed for measuring the modal parameters relying on the assumption that the structure is exposed to unknown random loads and the system is linear time-invariant during the analyzed time interval [91- 93]. Devriendt et al. [94] evaluated that by utilizing 10 minutes as time segment for monitoring of the OWT, adequate modal parameters could be identified properly. Regarding the active vibration-based structural health monitoring, Tcherniak and Mølgaard [95] presented a technique which is capable of detecting structural damages of WT blade. The mentioned investigation demonstrated the system on a Vestas V27 [96] wind turbine. It was demonstrated that, for the specific damage type introduced to the blade, even small damage of at least 15 cm size could be captured remotely without stopping the WT. The proposed SHM system relies on the vibration method, in which the plunger frequently hits the blade and the generated vibrations propagated along the blade are detected by installed accelerometers. The actuator was mounted outside the blade, on its upwind side about 1 m from the root as delineated in Fig. 16. 12 monoaxial piezoelectric accelerometers were used in this study and their locations on the blade are described in Fig.16 (d). However, it is worth mentioning that it is difficult to detect the defect using the frequency method as mentioned by [44].

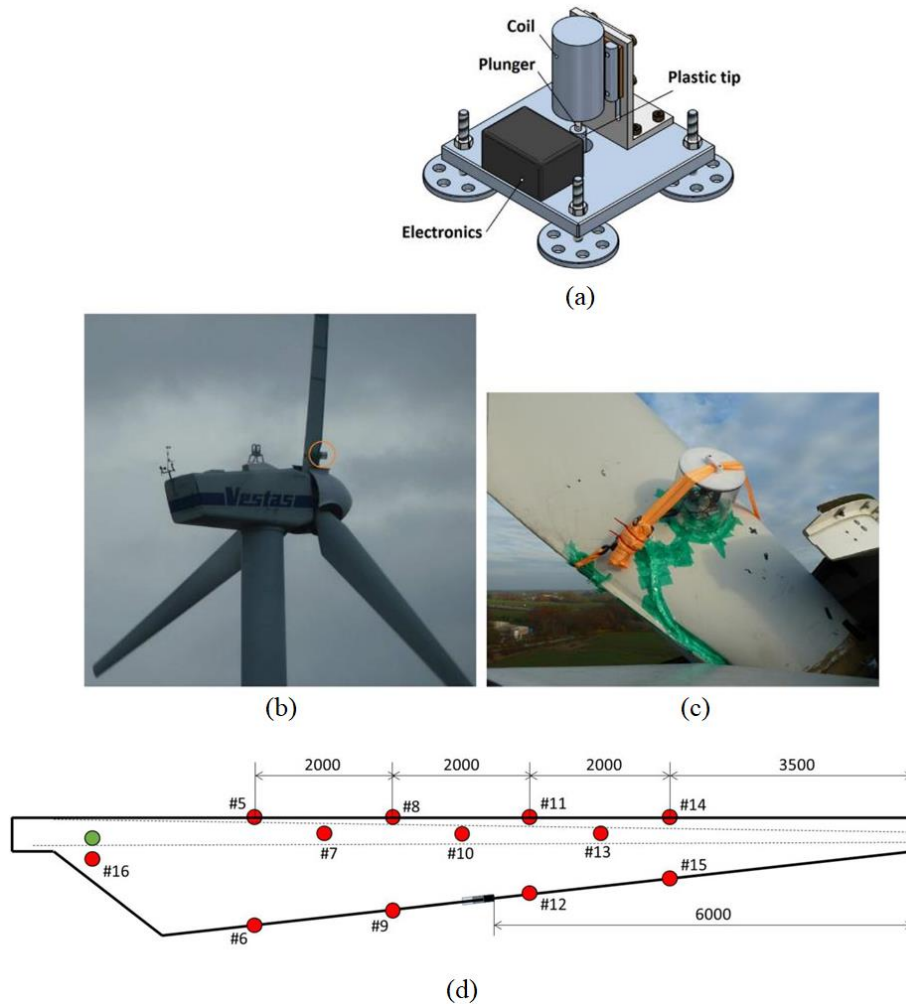

**Fig. 16.** Actuator (a) design, (b) actuator location (c) mounting on the blade (d) blade sketch indicating the red and green circles as the locations of the accelerometers and the location of the actuator, respectively [95]

The influence of the scour on the natural frequency of offshore wind turbine was studied by Weijtjens et al. [97], where it was demonstrated that by increasing the scour, the natural frequencies of the support structure, and therefore the wind turbine diminish. Vibration- based method with a three-tier structural health monitoring framework of a 34 m blade was exploited by Tsiapoki et al [98], for sake of damage and ice detection. The ice accretion steps on the blade tip is exhibited in Fig.17.

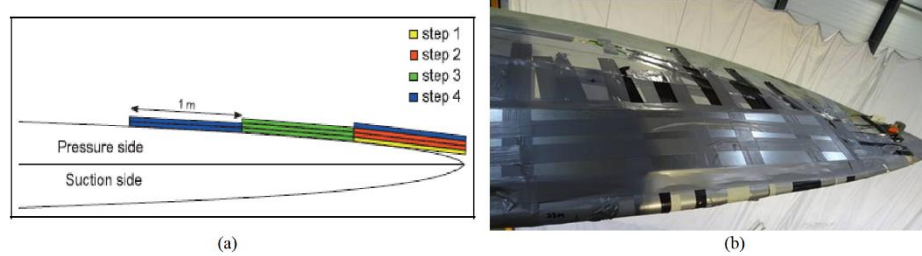

**Fig. 17.** (a) Ice accumulation steps, (b) Steel sheets mounted on blade surface for simulation of ice accretion [98]

Results from the modal test shown that structural alterations due to damage at the trailing edge and adding mass could be captured by changes in the condition parameters [98].

The 'IDD. Blade' ice detection system is a vibration-based blade condition monitoring system developed by Wölfel [78, 99], which measures vibrations of WT blades with structural noise sensors.

### 3.6 Employing Carbon nanotube (CNT) as damage impediment and sensor agents

As mentioned in the previous section, SHM approaches encompass the application of strain gages, accelerometers, piezoelectric sensors, and fiber optic sensors for measuring strain, vibration, etc. [100-104]. Many of these methods furnish sensing only near the sensor, so, they must be positioned near to critical regions for sake of damage detection. Thus, if damage takes place at other unexpected regions, it may go undetected. Several investigations have concentrated on piezoresistive polymers made by dispersing CNTs into a polymer to produce a conductive matrix [105-111]. Fuzzy fiber sensors exhibit promising features as low cost, low weight, and convenient consolidation within a composite material. Furthermore, they are insensitive to manufacturing methods or alignment. Thus, foregoing remarkable features can provide an extremely high number of sensing elements to be embedded inside a composite structure with the minimum cost and weight. Furthermore, adding CNT to the conventional composite can augment the interfacial and interlaminar strengths to preclude the delamination and debonding damages in the composite structures [112-117]. The SEM image of carbon fiber coated with CNT (fuzzy fiber), and the three-point bending test of hybrid composite (conventional composite with CNT's) are delineated in Fig. 18. As it can be seen, the bridging effect of CNT's at the interface represents the significant improvement of such nano-engineered materials regarding the interlaminar and interfacial strengths of the composite structures.

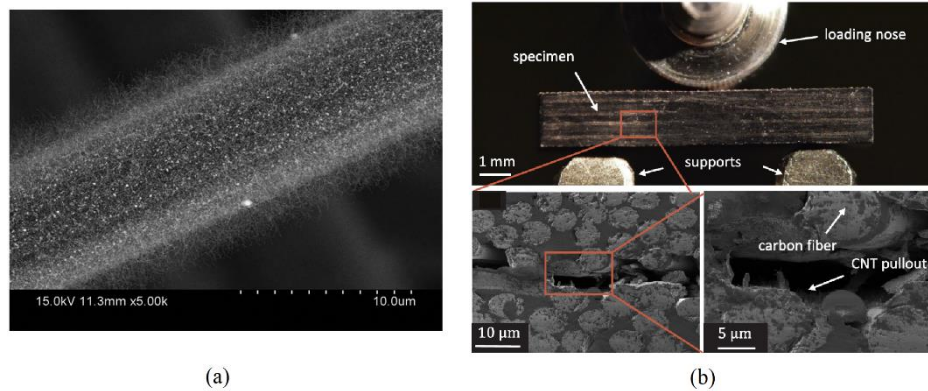

**Fig. 18.** (a) SEM micrograph of CNT growth on glass fiber (Fuzzy fiber) (b) short-beam shear (SBS) test configuration and the effect of CNT's which are pulled out of the polymer matrix during delamination [118, 119]

Sebastian et al. [118], utilized a novel, multi-modal, nanomaterial-based sensor technology that can provide wide area detection of damage in composite structure. The efforts presented in this research serve as a feasibility study into the incorporation of carbon nanomaterials into structural composites as sensors. Surprisingly, the carbon nanotube covered fiber (fuzzy fiber) sensors exhibit similar sensitivity to conventional strain gages and are more easily integrated into composite structures as the sensor itself is a composite. The fuzzy fiber strain gages can be employed to sense strain within composite structures and can be consolidated into the laminated composite to prepare sensing over large sections and in positions which are not accessible to conventional strain gauging approach. The superior properties of the fuzzy fiber provide its application in a wide range of sensing tasks within a composite structure including strain, temperature, degradation, etc.

Due to exceptional mechanical properties of CNT's and their potential to be used for monitoring the structural damage, application in wind industry is explored by several research groups [120-122]. These competitive advantages make CNT's attractive candidate for the reinforcement of composite long wind turbine blades with trivial increase in the blade weight, that can produce ultra-mega sources of clean energy [122]. A schematic application of CNT's- based wind turbine blades is illustrated in Fig. 19.

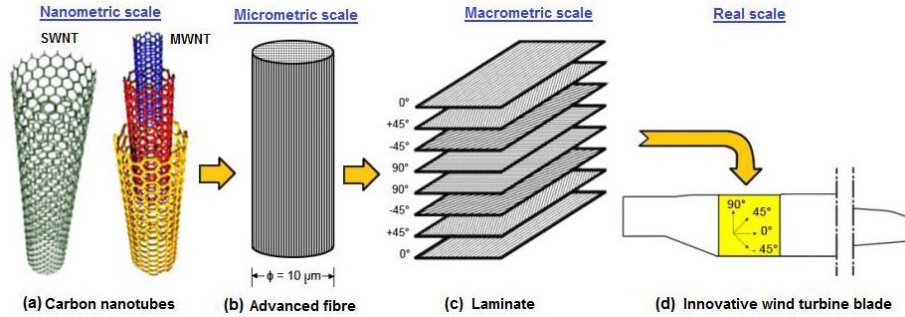

**Fig. 19.** Application of CNT-based continuous fibers for design of wind turbine blades [122]

As a classification, all the introduced methods with their advantages and disadvantages are represented in the Appendix.1.

## 4 Conclusion

The present work is devoted to preparation of a review of disparate structural health monitoring (SHM) methods of wind turbine blades encompassing active/ passive acoustic emission method, strain measurement method, vibration-based method, thermal imaging method and ultrasonic methods, based on the recent investigations. The damages considered in the present work are fiber breakage, matrix cracking, delamination, fiber debonding, crack opening at leading/ trailing edge and ice accretion. Moreover, employing the carbon nanotube (CNT) as both reinforcement agent and internal sensors for monitoring the internal health of the blade structure is introduced. Finally, the advantages and disadvantages of the represented methods are nominated and classified.

## Appendix.1

**Table A.** Comparison and classification of the introduced SHM methods

SHM Methods	Definitions/ Companies/ Employed Sensors	Advantages/ Capabilities	Disadvantages/ Limitations
<b>Acoustic Emission Method (AE)</b>	<ol style="list-style-type: none"> <li>The conventional method is based on the release of localized energy in form of elastic wave in material</li> <li>The damage process and stress waves also emit Airborne sound (audible crack)</li> <li>Two approaches as active and passive types</li> <li>Active Method: <ol style="list-style-type: none"> <li>Based on propagation of acoustic pressure in the air</li> <li>Using fiber optic microphones</li> <li>Eliminating the wave attenuation inside the material</li> <li>Optimizing number of speakers</li> <li>Optimizing the inside design of blade (avoiding narrow zone)</li> </ol> </li> <li>Passive Method: <ol style="list-style-type: none"> <li>Based on elastic wave propagation inside material</li> <li>More required sensors than Active method</li> <li>Conducting attenuation test for reducing the sensor numbers</li> </ol> </li> <li>Capable of detecting: Fiber breakage, Matrix cracking, Delamination, Fiber debonding, Crack opening at leading/ trailing; Also capable of fault detection in gearboxes, bearings, shafts</li> <li>Relevant Standards: ASTM E976, ASTM E2374- 15</li> <li>Prior knowledge of stress field using finite element analysis is required for detecting damage-prone locations</li> <li>Damage sound detection used by Ping Services company</li> </ol> <p><b>Employed Sensors:</b> Piezoelectric sensors, Fiber Optic Sensors, Fiber Brag Grating (FBG), Macro-fiber Composites Sensors (MFC)</p>	<ol style="list-style-type: none"> <li>Powerful in detecting/ identifying damages and their locations up to micro-scale</li> <li>Allowing a convenient, fast and cost-effective monitoring of a structure</li> <li>Proper response at low frequencies &amp; sensitive in detecting the incipient defect</li> <li>Detecting widespread types of damages</li> <li>Improving the damage evaluation capability of AE by employing Structural Neural System (SNS)</li> <li>Airborne sound method: <ol style="list-style-type: none"> <li>there is NO signal attenuation due the inherent feature of this method</li> <li>Due to use of microphone, the number of sensors is remarkably reduced than conventional passive AE</li> </ol> </li> </ol>	<ol style="list-style-type: none"> <li>Depending on the algorithm</li> <li>High sensitivity to background noise; Assessing the normal condition operating, different wind, and environment conditions such as raining condition, hailing, gust</li> <li>Attenuation of the signal during wave propagation inside the material (except Airborne method)</li> <li>Importance of sensor locations study for making cost-effective process</li> <li>Avoiding the installation of metallic components/ cables, due to lightning strike</li> <li>Airborne sound method: <ol style="list-style-type: none"> <li>Dependent on the environment noise</li> <li>Incapable of detecting small crack or detecting at incipient</li> </ol> </li> </ol>
<b>Strain Measurement Method</b>	<ol style="list-style-type: none"> <li>Detecting microscopic length changes in a structure</li> <li>Prior knowledge of stress field using finite element analysis is required for detecting critical areas for mounting the sensors</li> <li>Recently utilizing the optical fiber and FBG's strain sensors are highly attracted</li> <li>Employed by FOS4X GmbH company for damage detection based on FBG strain sensors</li> <li>Employed by Moog Insensys Ltd for ice and load measurement, based on four optical fiber strain sensors</li> </ol>	<ol style="list-style-type: none"> <li>Convenient installation process once proper training was implemented</li> <li>Mature technology</li> <li>Using fiber- optic sensors due to less prone to fatigue, eliminates wiring issues and allows more points to be monitored with the same cable</li> </ol>	<ol style="list-style-type: none"> <li>Mechanical properties limitations</li> <li>Sensitive of installation to misalignments</li> <li>Influenced by EMI noise (except FBG's)</li> <li>Distance between the sensor and the Data Acquisition System impresses accuracy and restricts location of sensor (except FBG's and optical fiber sensors)</li> </ol>



**Employed Sensors:**

Strain gauge (Capacitance, inductance, semiconductor, and resistance), Fiber Optic Sensors, Fiber Brag Grating (FBG)

1. Considering the modal parameters such as resonance frequency, mode shapes and modal damping, as functions of the physical properties of the structure (mass, stiffness & damping)
2. Changes in the physical properties, resulting from the onset of cracks or damage initiation, will lead to detectable changes in the modal properties
3. Detecting the damages in the structure by comparing between the response before and after occurring damage
4. Employed by FOS4X & Wölfel for ice and damage detection
5. Active vibration based SHM used by VESTAS company

6. Deferent analysis types of modal base method:
  - a. *Using PZT patches at the hot spots and exciting actuator, damage is detected using the differences of resonance response of healthy and damaged structure*
  - b. *Impedance-based SHM by monitoring the electrical impedance of the PZT*

7. Operational Modal Analysis (OMA)
  - a. *Considering that the system is linear and doesn't change during the time in the analyzed time interval*
  - b. *Compared with traditional experimental modal analysis (EMA), OMA does not require expensive excitation sources*

**Employed Sensors:**

Accelerometer, MEMS, optical fibers, FBGs, Velocimeter

1. Based on the fact: when a component starts to malfunction, the temperature increases beyond the normal values
2. Two approaches as passive and active method based on excitation method
3. Passive Method:  
Utilizing to investigate materials that are at a different temperature than ambient (often higher)- NOT common in SHM of wind turbines
4. Active Method:  
Employing an external stimulus source such as optical flash lamps, heat lamps, etc., for inducing pertinent thermal contrasts on the part
5. 'Thermoelastic stress method' as one type of active thermal imaging method, based on the thermoelastic effect
  - a. *Changing the temperature of material due to the change of stress in the structure*
  - b. *Necessity to apply load periodically on the component being tested, which results in growth of damage*

1. Reliable and mature technology
2. convenient mounting
3. Existing of many various techniques available based on this method
4. Solving some limitations based on development in Operational Modal Analysis

1. High number of uncertainties which makes difficult to accomplish a detailed dynamic/ modal analysis of the entire of the structure
2. Incapable of detecting very small damages or localizing damages at incipient level
3. Difficult analysis in operating conditions
4. Increasing the scour, leads to decrease the natural frequency of the support structure and therefore wind turbine
5. Considering the variation of environmental and operational conditions in the results
6. Due to uncertainties and unmeasurable input forces such as wind and waves, the Classical Experimental Modal Analysis (EMA) methods cannot be employed for offshore WT

**Vibration- Based Methods****Thermal Imaging Method**

1. Rapid assessment of the structure
2. Cost effective (Passive method)
3. Capable of producing a full-field measurement in image form

1. Detecting cracks depends on camera resolution
2. Impossible to penetrate in extended depths
3. Passive method:  
An important role of environmental conditions on outdoor infrared thermographic surveys (cloud cover, solar radiation, wind speed)
4. Active Method:  
Exciting the turbine on site, is not cost effective
5. Infeasible to use during the operation of a wind turbine, since the detection capability is constrained by the effect of environmental conditions
6. This method could be used as com-

**Employed Sensors:**

Impedance tomography, Thermography (infrared cameras)

plementary to other SHM method

1. Utilizing three different techniques for investigation:

*a. Pulse-echo Method**b. Through transmission Method**c. Pitch-catch Method*

2. Damage is detected by changing in wave reflection or time of flight, comparing with the time that a wave needs to travel a distance through a medium

3. Determining the defect position &amp; defect severity by transit time &amp; the amplitude, respectively

4. Revealing planar cracks (e.g. delamination) oriented perpendicular to the direction of sound wave propagation

**Employed Sensors:**

Piezoelectric transducers

1. Sensitive to both surface and subsurface discontinuities

2. The depth of penetration for flaw detection or measurement is superior to other NDT methods

3. Superior to other NDT methods

4. Only single-sided access is needed when the pulse-echo technique is used

5. It has other uses, such as thickness measurement, in addition to flaw detection

1. Difficulty in evaluation of irregular, rough, or non-homogeneous materials

2. Surface must be accessible to transmit ultrasound

3. Insensitive to single fiber rupture in fiber composites

4. Linear defects oriented parallel to the sound beam may go undetected

5. Requiring of reference standards for both equipment calibration and flaw characterization

6. Inefficient for full-scale SHM of large structures and it can be used as complementary method

**Ultrasonic Method**

## References

1. Soua, S., Van Lieshout, P., Perera, A., Gan, TH., Bridge, B.: Determination of the combined vibrational and acoustic emission signature of a wind turbine gearbox and generator shaft in service as a pre-requisite for effective condition monitoring. *Renew Energy*, 51 (2013), pp. 175-181.
2. Liu, W.Y., Tang, B.P., Han, J.G., Lu, X.N., Hu, N.N., He, Z.Z.: The structure healthy condition monitoring and fault diagnosis methods in wind turbines: a review. *Renew Sustain Energy Rev*, 44 (2015), pp. 466-472
3. Simani, S., Farsoni, S., Castaldi, P.: Fault diagnosis of a wind turbine benchmark via identified fuzzy models. *IEEE Trans Ind Electron*, 62 (2015), pp. 3775-3782
4. Martinez-Luengo, M., Kolios, A., Wang, L.: Structural health monitoring of offshore wind turbines: A review through the Statistical Pattern Recognition Paradigm. *Renew Sustain Energy Rev* 2016; 64:91–105.
5. Kim, H., Melhem, H.: Damage detection of structures under earthquake excitation using discrete wavelet analysis. *Eng Struct*, 26 (2004), pp. 347-362.
6. Yang, W., Tavner, P.J., Crabtree, C.J., Wilkinson, M.: Cost-effective condition monitoring for wind turbines. *IEEE Trans Ind Electron*, 57 (2010), pp. 263-271.
7. Zhou, H.F., Dou, H.Y., Qin, L.Z., Chen, Y., Ni, Y.Q., Ko, J.M.: A review of full-scale structural testing of wind turbine blades. *Renew Sustain Energy Rev*, 33 (2014), pp. 177-187.
8. Yang, R., He, Y., Zhang, H.: Progress and trends in nondestructive testing and evaluation for wind turbine composite blade. *Renew Sustain Energy Rev*.
9. Yang, B., Sun, D.: Testing, inspecting and monitoring technologies for wind turbine blades: a survey. *Renew Sustain Energy Rev*, 22 (2013), pp. 515-526.
10. Ciang, CC., Lee, J-R., Bang, H-J.: Structural health monitoring for a wind turbine system: a review of damage detection methods. *Meas Sci Technol* 2008.
11. Lian, J., Cai, O., Dong, X., Jiang, Q., Zhao, Y.: Health Monitoring and Safety Evaluation of the Offshore Wind Turbine Structure: A Review and Discussion of Future Development. *Sustainability* 2019, 11, 494.
12. Farrar, C R., Sohn, H.: Pattern recognition for structural health monitoring. 2000; Workshop on Mitigation of Earthquake Disaster by Advanced Technologies (Las Vegas, NV, USA, 30 Nov.–1 Dec. 2000).
13. Ghoshal, A., Sundaresan, M.J., Schulz, M.J., Pai, P.F.: Structural health monitoring techniques for wind turbine blades. *J Wind Eng Ind Aerodyn*, 85 (2000), pp. 309-324.
14. Adedipe, O., Brennan, F., Kolios, A.J.: Review of Corrosion fatigue in offshore structures: present status and challenges in the offshore wind sector. *Renew Sustain Energy Rev*, 61 (2016), pp. 141-154.
15. Larsen, FMF., Sorensen, T.: New lightning qualification test procedure for large wind turbine blades. *International Conference on Lightning* 2003; 36:1–10.
16. Schulz, M J., Sundaresan, M J.: Smart sensor system for structural condition monitoring of wind turbines. Subcontract Report NREL/SR-500-40089, 2006, National Renewable Energy Laboratory, CO, USA.
17. Caselitz, P., Giebhardt, J., Mevenkamp, M.: On-line fault detection and prediction in wind energy converters. 1994, Proc. EWEC (Thessaloniki, Greece) pp 623–7.
18. Schubel, P.J., Crossley, R.J., Boateng, E.K.G., Hutchinson, J.R.: Review of structural health and cure monitoring techniques for large wind turbine blades. *Renew Energy* 2013; 51:113–23.

19. Caithness Windfarm Information Forum 2005 Wind Turbine Accident Data to December 31st 2005, <http://www.caithnesswindfarms.co.uk/>.
20. Flemming, M L., Troels, S.: New lightning qualification test procedure for large wind turbine blades. 2003 Int.Conf. Lightning and Static Electricity (Blackpool, UK) pp 36.1–10.
21. Rosenbloom E 2006 *A Problem with Wind Power* [www.aweo.org](http://www.aweo.org).
22. J. Zangenberg, P. Brøndsted, M. Koefoed, Design of a fibrous composite preform for wind turbine rotor blades, *Mater. Des.* 56 (2014) 635–641. <https://doi.org/https://doi.org/10.1016/j.matdes.2013.11.036>.
23. Jureczko, M., Pawlak, M., Mezyk, A.: Optimisation of wind turbine blades. *J. Mater. Process. Technol.* 2005, 167 463–71.
24. Sørensen, B F., Jørgensen, E., Debel, C P., Jensen, F M., Jensen, H M., Jacobsen, T K., Halling, K M.: Improved design of large wind turbine blade of fibre composites based on studies of scale effects (Phase 1).2004, Summary Report (Risø-R Report) Risø National Laboratory, Denmark.
25. Sundaresan, M J., Schulz, M J., Ghoshal, A.: Structural health monitoring static test of a wind turbine blade. 2002, Subcontract Report NREL/SR-500-28719, National Renewable Energy Laboratory, CO, USA.
26. Balageas, D., Fritzen, C-P., Guemes, A.: Structural health monitoring. London, UK: ISTE Ltd; 2006.
27. Tchakoua, P., Wamkeue, R., Ouhrouche, M., Slaoui-Hasnaoui, F., Tameghe, T.A., Ekemb, G.: Wind Turbine Condition Monitoring: State-of-the-Art Review, New Trends, and Future Challenges. *Energies* 2014, 7, 2595-2630.
28. Tan, C.K., Irving, P., Mba, D.: A comparative experimental study on the diagnostic and prognostic capabilities of acoustics emission, vibration and spectrometric oil analysis for spur gears. *Mech. Syst. Signal Process.* 2007, 21, 208–233.
29. Krause, T., Preihs, S., Ostermann, J.: Detection of Impulse-Like Airborne Sound for Damage Identification in Rotor Blades of Wind Turbines. 7th European Workshop on Structural Health Monitoring (EWSHM 2014), July 8-11, 2014.
30. Van Dam, J., J. Bond, L.: Acoustic emission monitoring of wind turbine blades, in: SPIE Smart Structures and Materials and Nondestructive Evaluation and Health Monitoring. International Society for Optics and Photonics, 2015.
31. Takeda, N., Okabe, Y., Kuwahara, J., Kojima, S., Ogisu, T.: Development of smart composite structures with small diameter fibre Bragg grating sensors for damage detection: quantitative evaluation of delamination length in CFRP laminates using Lamb wave sensing, 2005, *Compos. Sci. Technol.* 65 2575–87.
32. Schulz, M J., Sundaresan, M J.: Smart sensor system for structural condition monitoring of wind turbines. 2006, Subcontract Report NREL/SR-500-40089, National Renewable Energy Laboratory, CO, USA.
33. Tang, J., Soua, S., Mares, C., Gan, TH.: A Pattern Recognition Approach to Acoustic Emission Data Originating from Fatigue of Wind Turbine Blades. *Sensors (Basel)*. 2017;17(11):2507.
34. Ni, Q.Q., Iwamoto, M.: Wavelet transform of acoustic emission signals in failure of model composites. *Eng. Fract. Mech.* 2002, 69, 717–728.
35. Gutkin, R.; Green, C.J.; Vangrattanachai, S.; Pinho, S.T.; Robinson, P.; Curtis, P.T. On acoustic emission for failure investigation in CFRP: Pattern recognition and peak frequency analyses. *Mech. Syst. Signal Process.* 2011, 25, 1393–1407.
36. Suzuki, M., Nakanishi, H., Iwamoto, M., Jinen, E.: Application of static fracture mechanisms to fatigue fracture behaviour of class A-SMC composite. In Proceedings of the 4th Japan-US Conference on composite materials, Washington, DC, USA, 27–29 June 1988

37. Ramirez-Jimenez, C.R., Papadakis, N., Reynolds, N., Gan, T.H., Purnell, P., Pharaoh, M.: Identification of failure modes in glass/polypropylene composites by means of the primary frequency content of the acoustic emission event. *Compos. Sci. Technol.* 2004, 64, 1819–1827.
38. Gómez Muñoz, C.Q., García Márquez, F.P.: A New Fault Location Approach for Acoustic Emission Techniques in Wind Turbines. *Energies* 2016, 9, 40.
39. NASA. <https://technology.nasa.gov/patent/LAR-TOPS-209>.
40. Tang, J., Soua, S., Mares, C., Gan, T-H.: An experimental study of acoustic emission methodology for in service condition monitoring of wind turbine blades. *Renew Energy* 2016; 99:170–9.
41. Stearman, RO., Schulze, GH., Rohre, SM.: Aircraft damage detection from acoustic and noise impressed signals found by a cockpit voice recorder. *J Acoust Soc Am* 1997; 101: 3085.
42. Fazenda, B., Comboni Bustos, D.: Acoustic condition monitoring of wind turbines: Tip faults. In: Proceedings of the 9th international conference on condition monitoring and machinery failure prevention technologies, London, 12–14 June 2012
43. Krause, T., Ostermann, J.: Damage detection for wind turbine rotor blades using airborne sound. *Struct Control Heal Monit* 2020,27.
44. Niezrecki, C., Inalpolat, M.: Structural health monitoring of wind turbine blades using wireless acoustic sensing. Patent PCT/US2014/062329, USA, 2015.
45. Beale, C., Niezrecki, C., Inalpolat, M.: An adaptive wavelet packet denoising algorithm for enhanced active acoustic damage detection from wind turbine blades. *Mech Syst Signal Process* 2020; 142:106754.
46. Beale, C., Inalpolat, M., & Niezrecki, C. (2020). Active acoustic damage detection of structural cavities using internal acoustic excitations. *Structural Health Monitoring*, 19(1), 48–65.
47. Ping Services, Australia, <https://www.pingmonitor.co/>
48. Avdelidis, N P., Almond, D P., Ibarra-Castanedo, C., Bendada, A., Kenny, S., Maldague, X.: Structural integrity assessment of materials by thermography Conf. Damage in Composite Materials CDCM 2006 (Stuttgart, Germany).
49. Hellier, C.J: Handbook of Nondestructive Evaluation; McGraw-Hill Professional Publishing: New York, NY, USA, 2003.
50. Krstulovic-Opara, L., Klarin, B., Neves, P., Domazet, Z.: Thermal imaging and Thermoelastic Stress Analysis of impact damage of composite materials *Eng Fail Anal*, 18 (2011), pp. 713-719.
51. Dutton, AG.: Thermoelastic Stress Measurement and Acoustic Emission Monitoring in Wind. European wind energy conference (EWEC) 2004, London 2004.
52. Hahn, F., Kensche, C.W., Paynter, R.J.H., Dutton, A.G., Kildegaard, J., Kosgaard, C.: Design, fatigue test and NDE of a sectional wind turbine rotor blade. *J Thermoplast Compos Mater*, 15 (2002), pp. 267-277.
53. Bodil, A., Mats, D., Magnus, U.: Feasibility Study of Thermal Condition Monitoring and Condition Based Maintenance in Wind Turbines. *Elforsk Report 11:19*; ELFORSK: Stockholm, Sweden, 2011.
54. Ge, Z., Du, X.; Yang, L., Yang, Y., Li, Y., Jin, Y.: Performance monitoring of direct air-cooled power generating unit with infrared thermography. *Appl. Therm. Eng.* 2011, 31, 418–424.
55. Walle, G., Abuhamad, M., Toma, E., Netzelmann, U.: Defect indications in sono-thermography in relation to defect location and structure. In: Proceedings of quantitative infrared thermography conference, Rhode Saint Genèse, Belgium 2004.

56. Rantala, J., Wu, D., Busse, G.: Amplitude modulated lock-in vibrothermography for NDE of polymers and composites. *J Res Nondestruct Eval*, 7 (1996), pp. 215-228.
57. Wilson, D W., Charles, J A.: Thermographic detection of adhesive-bond and interlaminar flaws in composites *Exp. Mech.* 21 276–80. 1981
58. Anastasi, R F., Zalameda J N.: Damage detection in rotorcraft composite structures using thermography and laser-based ultrasound. *NDT.net* 9 8. 2004
59. Li, S., Shi, K., Yang, K., Xu, J.: Research on the defect types judgment in wind turbine blades using ultrasonic NDT. *IOP Conference Series Materials Science and Engineering* 2015; 87:012056.
60. Rose, J.L.: Ultrasonic guided waves in structural health monitoring. *Key Eng. Mater.* 2004, 270, 14–21.
61. Raisutis, R., Jasiuniene, E., Sliteris, R., Vladisauskas, A.: The review of non-destructive testing techniques suitable for inspection of the wind turbine blades. *Ultrasound* 2008, 63, 26–30.
62. Hyers, R., McGowan, J., Sullivan, K., Manwell, J., Syrett, B.: Condition monitoring and prognosis of utility scale wind turbines. *Energy Mater.* 2006, 1, 187–203.
63. Drewry, M.A., Georgiou, G.A.: A review of NDT techniques for wind turbines. *Insight-Non-Destr. Test. Cond. Monit.* 2007, 49, 137–141.
64. Cheng, L., Tian, G.Y.: Comparison of nondestructive testing methods on detection of delaminations in composites. *J. Sens.* 2012, 2012.
65. Tuzzeo, D., Lanza di Scalea, F.: Noncontact air-coupled guided wave ultrasonics for detection of thinning defects in aluminum plates. *Res. Nondestr. Eval.* 13 61–78. 2001
66. Lee, J-R., Shin, H-J., Chia, CC., Dhital, D., Yoon, D-J., Huh, Y-H.: Long distance laser ultrasonic propagation imaging system for damage visualization. *Opt Lasers Eng* 2011; 49:1361–71.
67. Park, B., An, YK., Sohn, H.: Visualization of hidden delamination and debonding in composites through noncontact laser ultrasonic scanning. *Compos Sci Technol*, 100 (2014), pp. 10-18.
68. Dally, J.W., Riley W.F.: Experimental stress analysis. *J Appl Mech* (1996), p. 33.
69. Takeda, N.: Characterization of microscopic damage in composite laminates and real-time monitoring by embedded optical fiber sensors. *Int J Fatigue*, 24 (2002), pp. 281-289.
70. Doyle, C.: Fiber Bragg grating sensors—an introduction to Bragg gratings and interrogation techniques *Smart Fibers*. Ltd Report, 2003, [www.smartfibres.com](http://www.smartfibres.com).
71. Campanella, C.E., Cuccovillo, A., Campanella, C., Yurt, A., Passaro, V.M.N.: Fiber Bragg Grating Based Strain Sensors: Review of Technology and Applications. *Sensors* 2018, 18, 3115.
72. Iodice, M., Striano, V., Cappuccino, G., Palumbo, A., Cocorullo, G.: Fiber Bragg grating sensors-based system for strain measurements. *Proc. 2005 IEEE/LEOS Workshop on Fibres and Optical Passive Components (Palermo, Italy)* pp 307–12.
73. <https://fbgs.com/technology/fbg-principle/>.
74. Schroeder, K., Ecke, W., Apitz, J., Lembke, E., Lenschow, G.: A fibre Bragg grating sensor system monitors operational load in a wind turbine rotor blade. *Meas Sci Technol* 2006; 17:1167–72.
75. FOS4X GmbH, Germany, <https://fos4x.com/en/downloads/>
76. FIBERSAIL, Netherlands, <http://www.fibersail.com/>
77. Perovic, S., Osborne, M., Lloyd, G., Bridges, P.: Intelligent Blade Ice Detection and Measurement. (Moog Insensys Ltd., Southampton, UK.) *European Wind Energy Conference & Exhibition*. Warsaw, Poland. 2010

78. Cattin, R., Heikkilä, U.: Evaluation of ice detection systems for wind turbines. Final report, 2015.
79. Carden, E.P.: Vibration based condition monitoring: a review. *Struct Health Monit*, 3 (2004), pp. 355-377.
80. Farrar, C.R., Doebling, S.W.: Damage detection and evaluation II: field applications to large structures. *Modal Anal Test NATO Sci Ser*, 363 (1999), pp. 345-378.
81. Abbasi, A., Khadem, S.E., Ghandchi-Tehrani, M.: Chaos suppression of a macro electro-mechanical system via linear feedback control based on Lyapunov exponent theorem, 5th International Conference on Acoustics and Vibration
82. Abbasi, A., Khadem, S., & Bab, S. (2018). Vibration control of a continuous rotating shaft employing high-static low-dynamic stiffness isolators. *Journal of Vibration and Control*, 24(4), 760–783.
83. Bab, S., Khadem, S.E., Shahgholi, M., Abbasi, A.: Vibration attenuation of a continuous rotor-blisk-journal bearing system employing smooth nonlinear energy sinks. *Mechanical Systems and Signal Processing* 84 (2017): 128-157.
84. Gross, E., Simmermacher, T., Rumsey, M., Zadoks, R I: Application of damage detection techniques using wind turbine modal data. American Society of Mechanical Engineers Wind Energy Symp. (Reno, NV, USA) AIAA 99-0047. 1999
85. Farrar, C R., Doebling, S W.: An overview of modal-based damage identification methods DAMAS 97 (Sheffield, UK). 1997
86. Doebling, S W., Farrar, C R., Prime, M B.: A summary review of vibration-based damage identification methods, *Shock Vib. Dig.* 30 91–105. 1998
87. Jang, J.-H., Yeo, I., Shin, S., Chang, S.-P.: Experimental investigation of system identification-based damage assessment on structures. *J Struct Eng*, 128 (2002), pp. 673-682.
88. Ghoshal, A., Sundaresan, M J., Schulz, M J., Pai, P F.: Structural health monitoring techniques for wind turbine blades, *J. Wind Eng. Ind. Aerodyn.* 85 309–24. 2000
89. Park, G., Sohn, H., Farrar, C R., Inman, D J.: Overview of piezoelectric impedance-based health monitoring and path forward, *Shock Vib. Dig.* 35 451–63. 2003
90. Pitchford, C., Grisso, B.L., Inman, D.J.: Impedance-based structural health monitoring of wind turbine blades. *Proc.SPIE*, vol. 6532, 2007. doi:10.1117/12.715800.
91. Hermans, L., Van Der Auweraer, H.: Modal testing and analysis of structures under operational conditions: industrial applications. *Mech Syst Signal Process*, 13 (1999), pp. 193-216.
92. Devriendt, C., El-kafafy, M., Sitter, G De., Guillaume, P.: Damping estimation of offshore wind turbines on a monopile foundation using state-of-the-art operational modal analysis techniques. *International Conference on Noise and Vibration Engineering*, Leuven 2012:2647–62.
93. Devriendt, C., Magalhães, F., Weijtjens, W., De Sitter, G., Cunha, Á., & Guillaume, P.: Structural health monitoring of offshore wind turbines using automated operational modal analysis, *Structural Health Monitoring*, 13(6), 644–659. (2014)
94. Devriendt, C., Jan Jordaens, P., De Sitter, G., Guillaume, P.: Damping estimation of an offshore wind turbine on a monopile foundation. *IET Renewable Power Generation* 2013; 7(4): 401–412.
95. Tcherniak, D., Mølgaard, L. L.: Active vibration-based structural health monitoring system for wind turbine blade: Demonstration on an operating Vestas V27 wind turbine. *Structural Health Monitoring*, 16(5), 536–550. 2017
96. Vestas, Denmark, <https://www.vestas.com/>

97. Weijtjens, W., Verbelen, T., De Sitter, G., Devriendt, C.: Foundation structural health monitoring of an offshore wind turbine: a full-scale case study. *Struct Health Monit* (2015).
98. Tsiapoki, S., Häckell, M. W., Griebmann, T., & Rolfes, R.: Damage and ice detection on wind turbine rotor blades using a three-tier modular structural health monitoring framework. *Structural Health Monitoring*, 17(5), 1289–1312.2018
99. Wölfel Group, Germany, <https://www.woelfel.de/en/home.html>
100. Bois, C., Herzog, P., Hochard, C.: Monitoring a delamination in a laminated composite beam using in-situ measurements and parametric identification. *J Sound Vib* 2007; 299:786–805.
101. Zou, Y., Tong, L., Steven, P.: Vibration-based model-dependent damage (delamination) identification and health monitoring for composite structures – a review. *J Sound Vib* 2000;230(2):357–78.
102. Leng, J., Asundi, A.: Structural health monitoring of smart composite materials by using EFPI and FBG sensors. *Sens Actuators A* 2003;103(3):330–40.
103. Ignatovich, S. R., Menou, A., Karuskevich, M. V., Maruschak, P. O.: Fatigue damage and sensor development for aircraft structural health monitoring. *Theor Appl Fract Mech* 2013; 65:23-27.
104. Teo, Y. H., Chiu, W. K., Chang, F. K., Rajic, N.: Optimal placement of sensors for sub-surface fatigue crack monitoring: *Theor Appl Fract Mech* 2009; 52: 40-49.
105. Karimov, KS., Khalid, FA., Chani, MTS. Carbon nanotubes-based strain sensors. *Measurement* 2012; 45:918–21.
106. Kang, I., Schulz, MJ., Kim, JH., Shanov, V., Shi, D.: A carbon nanotube strain sensor for structural health monitoring. *Smart Mater Struct* 2006;15(3):737–48.
107. Thostenson, ET, Chou, T-W.: Real-time in situ sensing of damage evolution in advanced fiber composites using carbon nanotube networks. *Nanotechnology* 2008; 19:1–6.
108. Alamusu, HuN., Fukunaga, H., Atobe, S., Liu, Y., Li, J.: Piezoresistive strain sensors made from carbon nanotubes-based polymer nanocomposites. *Sensors* 2011; 11:10691–723.
109. Arash, A., Jiang, JW, Rabczuk, T.: A review on nanomechanical resonators and their applications in sensors and molecular transportation. *Applied Physics Reviews* 2, 021301 (2015).
110. Grow, RJ., Wang, Q., Cao, J., Wang, D., Dai, H.: Piezoresistance of carbon nanotubes on deformable thin-film membranes. *Appl Phys Lett* 2005; 86:93–104.
111. Boehle, M., Jiang, Q., Li, L., Lagounov, A., Lafdi, K.: Carbon nanotubes on glass fiber as a strain sensor for real time structural health monitoring. *Int J Smart Nanomater* 2012;3(2):162–8.
112. Malekimoghadam, R., Icardi, U.: Prediction of mechanical properties of carbon nanotube–carbon fiber reinforced hybrid composites using multi-scale finite element modelling. *Compos Part B Eng* 2019; 177:107405.
113. Vu-Bac, N., Lahmer, T., Zhang, Y., Zhuang, X., Rabczuk, T.: Stochastic predictions of interfacial characteristic of polymeric nanocomposites (PNCs). *Compos Part B Eng* 2014. doi: 10.1016/j.compositesb.
114. M.A. Msekh, N.H. Cuong, G. Zi, P. Areias, X. Zhuang, T. Rabczuk, Fracture properties prediction of clay/epoxy nanocomposites with interphase zones using a phase field model, *Eng. Fract. Mech.* 188, 287-299.
115. Silani, M., Ziaei-Rad, S., Talebi, H., Rabczuk, T.: A semi-concurrent multiscale approach for modeling damage in nanocomposites. *Theor Appl Fract Mech* 2014; 74:30–8.



116. Hosseini, S.A., Saber-Samandari, S., Maleki Moghadam, R.: Multiscale modeling of interface debonding effect on mechanical properties of nanocomposites. *Polym Compos* 2017; 38:789–96.
117. R.M. Moghadam, S. Saber-Samandari, S.A. Hosseini. On the tensile behavior of clay–epoxy nanocomposite considering interphase debonding damage via mixed-mode cohesive zone material. *Compos Part B Eng* 2016; 89:303–15.
118. Sebastian, J., Schehl, N., Bouchard, M., Boehle, M., Li, L., Lagounov, A., Lafdi, K.: Health monitoring of structural composites with embedded carbon nanotube coated glass fiber sensors. *Carbon N Y* 2014; 66:191–200.
119. Ni, X., Furtado, C., Kalfon-Cohen, E., Zhou, Y., Valdes, G.A., Hank, T.J., Camanho, P.P., Wardle, B.L.: Static and fatigue interlaminar shear reinforcement in aligned carbon nanotube-reinforced hierarchical advanced composites. *Compos Part A Appl Sci Manuf* 2019; 120:106–15.
120. Dai, G., Mishnaevsky, Jr L.: Carbon nanotube reinforced hybrid composites: Computational modeling of environmental fatigue and usability for wind blades. *Compos Part B Eng* 2015; 78:349–60.
121. Zhou, H.W., Mishnaevsky, L., Yi, H.Y., Liu, Y.Q., Hu, X., Warrier, A., Dai, G.M.: Carbon fiber/carbon nanotube reinforced hierarchical composites: Effect of CNT distribution on shearing strength. *Compos Part B Eng* 2016; 88:201–11.
122. Attaf, B.: On the Application of Carbon Nanotube-Based Composite Materials for Smart Design of Wind Turbine Blades, International Conference on Materials and Energy ICOME 16, La Rochelle, France, 17- 22 May 2016.