



POLITECNICO DI TORINO  
Repository ISTITUZIONALE

Pencil graphite needle-shaped biosensor for anaesthetic monitoring in human serum

*Original*

Pencil graphite needle-shaped biosensor for anaesthetic monitoring in human serum / Aiassa, Simone; Yilmaz, Sinan; Carrara, Sandro; Demarchi, Danilo. - ELETTRONICO. - (2020), pp. 1-4. ((Intervento presentato al convegno 2020 IEEE Sensors tenutosi a Rotterdam (NLD) nel October 25-28, 2020.

*Availability:*

This version is available at: 11583/2846198 since: 2020-12-10T10:40:05Z

*Publisher:*

IEEE

*Published*

DOI:10.1109/SENSORS47125.2020.9278590

*Terms of use:*

openAccess

This article is made available under terms and conditions as specified in the corresponding bibliographic description in the repository

*Publisher copyright*

IEEE postprint/Author's Accepted Manuscript

©2020 IEEE. Personal use of this material is permitted. Permission from IEEE must be obtained for all other uses, in any current or future media, including reprinting/republishing this material for advertising or promotional purposes, creating new collecting works, for resale or lists, or reuse of any copyrighted component of this work in other works.

(Article begins on next page)

# Pencil Graphite Needle-Shaped Biosensor for Anaesthetic Monitoring in Human Serum

Simone Aiassa<sup>\*†</sup>, Sinan Yilmaz<sup>†</sup>, Sandro Carrara<sup>†</sup>, and Danilo Demarchi<sup>\*</sup>

<sup>\*</sup>Department of Electronics and Telecommunications, Politecnico di Torino, Turin, Italy

<sup>†</sup>Integrated Systems Laboratory, École Polytechnique Fédérale de Lausanne, Lausanne, Switzerland

Email: simone.aiassa@polito.it

**Abstract**—Direct and online continuous monitoring of anaesthetic intake by the patient’s blood stream improves practices in the critical procedure of anaesthesia. Several systems have been proposed to address this challenge. Electrochemical techniques are highly appealing because of speed and accuracy, while blood spot sampling and fluidic devices are discouraged in this application, due to the necessity of having constant and continuous monitoring. To overcome this limitation, we developed a sensor suitable for measuring anaesthetics directly in patient’s vein. We present here, for the first time, a disposable and low-cost needle-shaped sensor based on a three-electrode electrochemical cell, made of pencil leads and platinum wire. The proposed sensor shows high linearity (99%) in measuring propofol directly in undiluted human serum at the temperature of 37°C in its therapeutic range (30–240 µM), with a limit of detection of  $7.2 \pm 3.0$  µM.

**Index Terms**—Anaesthetic, Biosensor, Needle-Shaped, Pencil Graphite, Therapeutic Drug Monitoring.

## I. INTRODUCTION

Anaesthesia is a challenging medical procedure in which the appropriate sedation is obtained through a balanced delivery of several drugs, including anaesthetics, analgesics and muscle relaxants. The concentrations of these compounds must be accurately maintained in the patient’s body to avoid side effects [1]. Today, prediction models represent the golden standard to estimate the right dosage of anaesthetics, but they still show high errors due to the patient’s heterogeneity [2]. Differently, the Therapeutic Drug Monitoring (TDM) aims to measure the actual drug concentration in the patient’s fluids to meet the personal requirements with a dynamic adjustment of the anaesthetics infusion [3].

Propofol (PPF) drug is a widely adopted anaesthetic, and it is considered the preferable solution with respect to inhalations drugs in general anaesthesia [4]. Due to its vast usage, the direct monitoring of propofol will improve success in the anaesthesia procedure. There is a growing interest in the use of blood spot sampling for TDM, usually obtained from finger pricks, which allows simple and cost-effective logistics [5], but it is not suitable for constant and continuous monitoring in the surgery room. Non-invasive methods for monitoring propofol concentration were presented using virtual surface acoustic wave techniques [6] and fast gas chromatography [7]. Nevertheless, electrochemical sensors are highly attractive for anaesthetics due to low-cost, ease of use, robustness, and stability [8]. In particular, Cyclic Voltammetry (CV) detection [9] showed excellent capabilities in online measuring of

drugs [10], [11]. In CV, a voltage staircase is applied to a three-electrode electrochemical cell (Working Electrode WE, Counter Electrode CE, and Reference Electrode RE), and triggers the Redox on the cell surface. The resulting Faradaic current is measured extracting the current vs voltage graph, called voltammograms, revealing the Redox peaks, which directly relates to the drug concentration according to the Randles-Ševčík equation [12].

Recently, several systems for monitoring anaesthetics have been presented [13], [14]. Notwithstanding, those implementations lack a sensor capable of measuring directly in-situ the concentration of anaesthetics. They leverage on external fluidic chambers [13] or commercial screen-printed electrodes for blood spot sampling [14], which both hardly cope with the usage during surgery. To overcome these limitations, we propose a needle-shaped electrochemical sensor for measuring propofol directly in the patient’s vein.

Pencil Graphite Electrode (PGE) are suitable for drug monitoring [15] and propofol monitoring, assuring compensation of the fouling phenomena [16]. We implemented a novel low-cost and disposable electrode with PGE pencil lead electrodes of

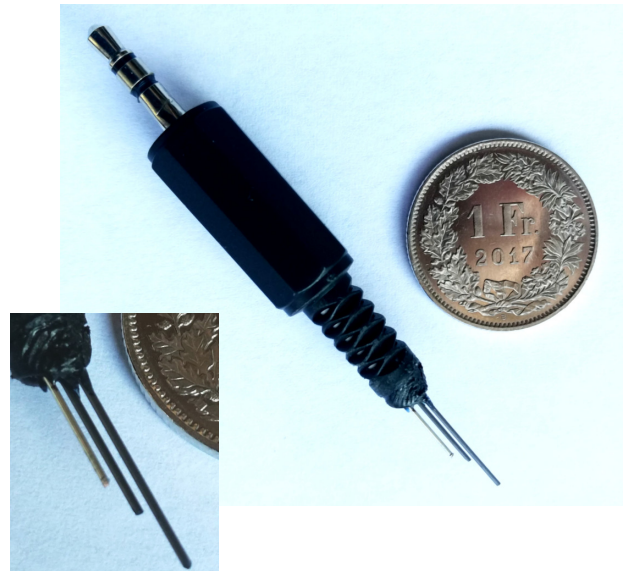

Fig. 1: The novel disposable and low-cost needle-shaped electrochemical sensor.

sub-millimetre size in a needle-shape. This paper presents and details the full process of assembly of the proposed needle-shaped sensor. Finally, the proposed electrode is tested in undiluted human serum at 37 °C to show its performances in the human body. The performance assessment is done in the therapeutic range between 30  $\mu\text{M}$  and 240  $\mu\text{M}$ , considering propofol therapeutic concentration can reach up to 40 mg/l (224  $\mu\text{M}$ ) [17].

## II. THE NEEDLE-SHAPED SENSOR

The proposed sensor is a three-electrode electrochemical cell in a needle-shape to target direct in-vein drug monitoring. Fig. 1 shows the complete sensor, with the electrochemical cell on the bottom, the case in the middle, the audio jack connector for disposable use on top. As detailed in Fig. 2, the sensor is composed of two PGE, which are 0.5 mm diameter HB mechanical pencil lead from Papeteria Migros, and one 0.3 mm diameter platinum wire. Similarly to what presented in [19], the WE is the first pencil lead, with a length of 10 mm and an active area of 15.9 mm<sup>2</sup>. The second pencil lead is the CE, with a length of 15 mm to maintain a ratio between the area of WE and CE smaller than one. The RE is the Pt wire, with a length of 8 mm. The different length of wires ensures the correct active area ratio among the different electrodes, which is required for best design practice in electrochemical sensors [18].

Fig. 3 displays the full assembly process of the proposed sensor. In step (a), the two pencil leads and the platinum wire are interfaced to a solid 22 AWG black soldering wire, and the connections are stabilized through polyolefin 2 mm diameter red heat-shrink tubes. In step (b), the three electrodes are joint together with a polyolefin 6 mm diameter white heat-shrink tube. In step (c), the three cable-ends are soldered to the three pins of a male audio jack 3.5 mm stereo connector. The sensor is completed in step (d) after closing the cover of the audio jack connector and cutting the three electrodes to length. The electrode tip is cleaned with ethanol first, distilled water second. The sensor is then immersed in PBS, pH 7.4, and ten CV cycles at Scan Rate (SR) of 0.5 V/s in the voltage window between  $-0.6$  V and 0.7 V are performed to ensure uniformity on the electrode surface and check connection faults. In the

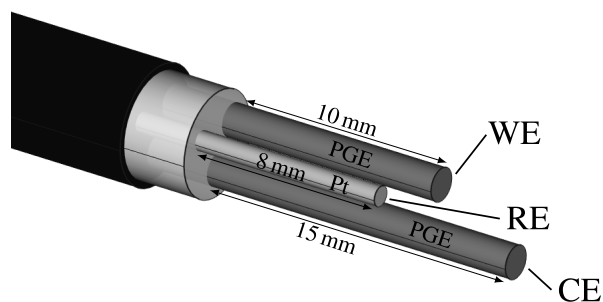

Fig. 2: Sensor illustration, two PGE electrodes are WE (shorter) and CE (longer), while Pt wire is RE, joint together in a needle-shape.

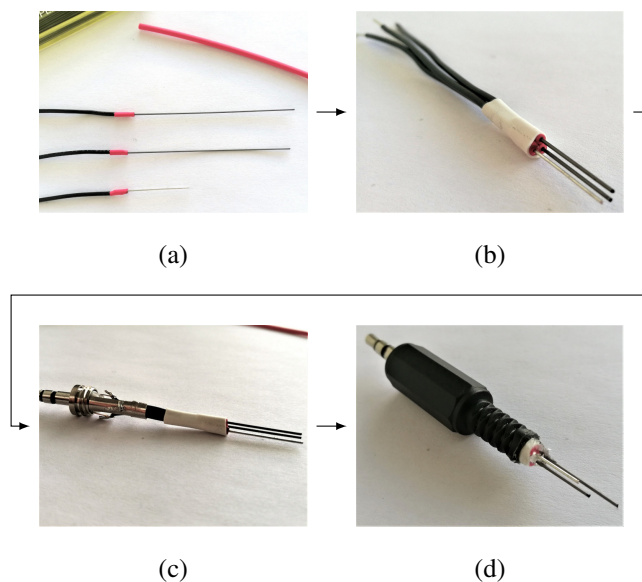

Fig. 3: Sensor assembly process: pencil leads and Pt wire connected to soldering wire through heat-shrink tubes (a), joint together (b), soldered to audio jack connector (c), closed and cut to length to form the complete sensor with integrated audio jack connector for point-of-care applications (d).

end, the sensor is cleaned with distilled water, let it dry, and stored in a dry cabinet.

The design of the presented sensor is the results of a study performed through potassium ferrocyanide to define the best geometry for a disposable and miniaturized sensor. It is worth to be noticed that the platinum pseudo reference electrode proposed in this work did not show any visible difference of stability when compared against silver pseudo reference electrodes present on commercial Screen Printed Electrodes (SPEs). The audio jack connector provides a low cost, disposable, and robust electrical interface to drug monitoring systems and electronics, being audio jack a robust and widely adopted standard.

## III. MATERIALS AND METHODS

A stock solution of 5.4 mM propofol is prepared the day of use dissolving 2,6-Diisopropylphenol (propofol - PPF) purchased from TCI in 0.1 M NaOH. Undiluted human serum, heat-inactivated from human male AB plasma, from Sigma-Aldrich is used as background. The samples are prepared with subsequent dilutions of propofol stock solution in human serum in a 10 ml beaker to obtain eight different concentrations, equally spaced in the range of interest: 30  $\mu\text{M}$ , 60  $\mu\text{M}$ , 90  $\mu\text{M}$ , 120  $\mu\text{M}$ , 150  $\mu\text{M}$ , 180  $\mu\text{M}$ , 210  $\mu\text{M}$ , and 240  $\mu\text{M}$ . The samples are continuously kept at 37 °C and continuously stirred by a hot plate stirrer from VWR<sup>®</sup>. The needle-shaped sensor is immersed in the sample solution, and it is connected to a commercial potentiostat, the Metrohm Autolab PGSTAT 302N, driven by the software Nova 1.11. The CV is performed at SR of 0.1 V/s, in the voltage windows between  $-0.6$  V and

0.7 V, with a step voltage of 5 mV, and a step time of 30 ms. All the measurements are repeated three times with three different assembled sensors to validate repeatability and reproducibility.

The data are elaborated by Matlab<sup>®</sup> (v. R2020a). The voltammogram curves are filtered with a low-pass filter at the cut-off frequency of 2 Hz to remove electrical noise. The background-current obtained by the blank measurement is subtracted to remove chemical noise. Finally, the peaks are detected with findpeaks built-in function to return the height of the oxidation-current peaks. The calibration curve is derived by regression built-in function. The Limit of Detection (LOD) is computed as three times the standard deviation of the blank measure around the peak, divided by the sensitivity.

#### IV. RESULTS AND DISCUSSION

The proposed sensor had been tested for propofol monitoring in undiluted human serum at body temperature (37°C), in the therapeutic range. Fig. 4 shows the results of the experimental setup detailed in Section II. Namely, Fig. 4 displays the voltammogram curves acquired by the lab instrument connected to the proposed sensor. The Faradaic peaks related to the propofol oxidation are visible between 0.4 V and 0.5 V. The peaks are highlighted filtering the signal with a low-pass filter at 2 Hz and removing the baseline.

Fig. 5 shows the resulting calibration point with their confidence interval (derived as three times the standard deviation) and the calibration curve of the proposed sensor. The curve is obtained linearly interpolating the values of the oxidation current-peaks. The calibration displays the performance of the proposed sensor considering repeatability and reproducibility since it is obtained by an inter-electrode analysis. As summarized by Table I, the sensor Sensitivity (S, the calibration coefficient) is  $9.4 \pm 3.9$  nA/ $\mu$ M. The coefficient of determination of linear regression ( $r^2$ ) is higher than 99%, indicating a good fit of the linear regressor to the calibration. The LOD, which

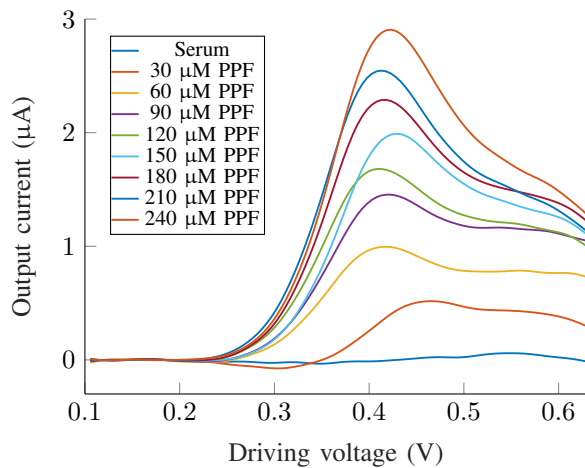

Fig. 4: Voltammograms acquired by analysis of propofol sample in human serum showing oxidation peaks after signal filtering and baseline subtraction, considering one sensor.

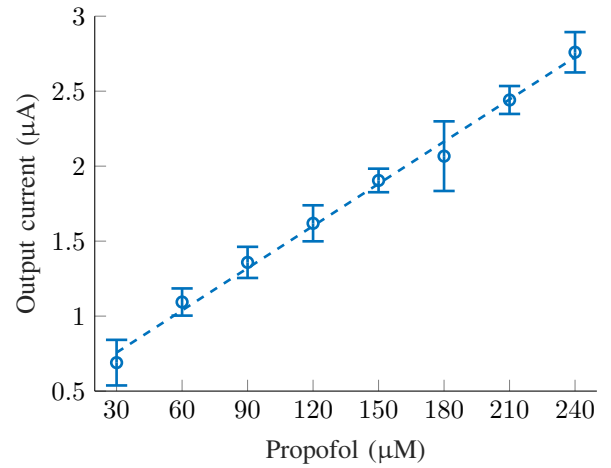

Fig. 5: Inter-electrodes calibration curve of proposed needle-shaped sensor measuring propofol in human serum.

TABLE I: Inter-electrodes performance results.

Sensitivity	$9.4 \pm 3.9$ nA/ $\mu$ M
Coefficient of Determination ( $r^2$ )	0.99
Limit of Detection (LOD)	$7.2 \pm 3.0$ $\mu$ M
Peak position	$462 \pm 37$ mV

is the minimum concentration of propofol detectable by the sensor, is  $7.2 \pm 3.0$   $\mu$ M, lower than the minimum concentration of interest. The peak position is stable around  $462 \pm 37$  mV, over-time and inter-electrodes, proving the performance and stability of the platinum wire pseudo-reference electrode. The reproducibility is assured by the repetition of the measurement on three different items of the proposed sensor. All these results confirm the effectiveness of the sensor for the target application.

#### V. CONCLUSION

We presented a new pencil graphite needle-shaped electrochemical sensor for direct monitoring of anaesthetics that can improve anesthesiology practices. The sensor is disposable and low-cost, being composed of pencil leads and platinum wire, with the help of an audio jack connector. The proposed sensor featured 99% linearity and a limit of detection of  $7.2 \pm 3.0$   $\mu$ M in human serum between 30  $\mu$ M and 240  $\mu$ M of propofol at 37°C, proving optimal performance for the target application. In the near future, the here proposed sensor will be interfaced to a full portable electronic system for anaesthetic monitoring.

#### ACKNOWLEDGMENT

This work is supported by Politecnico di Torino and Compagnia di San Paolo under the initiative “Joint research projects with top universities”. The authors would like to thank Dr. Francesca Stradolini for her helpful advice.

## REFERENCES

- [1] C. D. Kent and K. B. Domino, "Depth of anesthesia," *Current Opinion in Anesthesiology*, vol. 22, no. 6, pp. 782–787, 2009.
- [2] H.-C. Lee, H.-G. Ryu, E.-J. Chung, and C.-W. Jung, "Prediction of bispectral index during target-controlled infusion of propofol and remifentanyl," *Anesthesiology*, vol. 128, no. 3, pp. 492–501, 2018.
- [3] A. Simalatsar, M. Guidi, P. Roudit, and T. Buclin, "Robustness analysis of personalized delivery rate computation for IV administered anesthetic," *Smart Health*, vol. 9, pp. 101–114, 2018.
- [4] K. Peng, H.-Y. Liu, S.-R. Wu, H. Liu, Z.-C. Zhang, and F.-H. Ji, "Does propofol anesthesia lead to less postoperative pain compared with inhalational anesthesia?: a systematic review and meta-analysis," *Anesthesia & Analgesia*, vol. 123, no. 4, pp. 846–858, 2016.
- [5] M. V. Antunes, M. F. Charão, and R. Linden, "Dried blood spots analysis with mass spectrometry: potentials and pitfalls in therapeutic drug monitoring," *Clinical Biochemistry*, vol. 49, no. 13–14, pp. 1035–1046, 2016.
- [6] F. Zhang, H. Dong, X. Zhang, J. Guo, Y. Liu, C. Zhou, X. Zhang, J. Liu, M. Yan, and X. Chen, "A non-invasive monitoring of propofol concentration in blood by a virtual surface acoustic wave sensor array," *Analytical Sciences*, vol. 33, no. 11, pp. 1271–1277, 2017.
- [7] H. Dong, F. Zhang, Y. Wang, F. Wang, J. Chen, K. G. Muhammad, and X. Chen, "Sniffing sevoflurane and propofol in exhalation from patients during balanced anesthesia," *2017 ISOCS/IEEE International Symposium on Olfaction and Electronic Nose (ISOEN)*, Montreal, Canada, 2017, pp. 1–3.
- [8] F. Stradolini, T. Elboshra, A. Biscantini, G. De Micheli, and S. Carrara, "Simultaneous monitoring of anesthetics and therapeutic compounds with a portable multichannel potentiostat," *2016 IEEE International Symposium on Circuits and Systems (ISCAS)*, Montreal, Canada, 2016, pp. 834–837.
- [9] S. Aiassa, S. Carrara, and D. Demarchi, "Optimized sampling rate for voltammetry-based electrochemical sensing in wearable and IoT applications," *IEEE Sensors Letters*, vol. 3, no. 6, pp. 1–4, 2019.
- [10] I. Ny Hanitra, F. Criscuolo, N. Pankratova, S. Carrara, and G. De Micheli, "Multichannel front-end for electrochemical sensing of metabolites, drugs, and electrolytes," *IEEE Sensors Journal*, vol. 20, no. 7, pp. 3636–3645, 2020.
- [11] S. Aiassa, J. D. González Martínez, D. Demarchi, and S. Carrara, "New Measurement Method in Drug Sensing by Direct Total-Charge Detection in Voltammetry," *2020 IEEE International Symposium on Medical Measurements and Applications (MeMeA)*, Bari, Italy, 2020, pp. 1–6.
- [12] S. Carrara, *Bio/CMOS interfaces and co-design*. New York: Springer Science, 2012.
- [13] F. Stradolini, A. Tuoheti, T. Kilic, S. L. Ntella, N. Tamburrano, Z. Huang, G. De Micheli, D. Demarchi, and S. Carrara, "An IoT solution for online monitoring of anesthetics in human serum based on an integrated fluidic bioelectronic system," *IEEE Transactions on Biomedical Circuits and Systems*, vol. 12, no. 5, pp. 1056–1064, 2018.
- [14] S. Aiassa, F. Stradolini, A. Tuoheti, S. Carrara, and D. Demarchi, "Quasi-digital biosensor-interface for a portable pen to monitor anaesthetics delivery," *2019 15th Conference on Ph.D Research in Microelectronics and Electronics (PRIME)*, Lausanne, Switzerland, 2019, pp. 265–268.
- [15] A. Tuoheti, S. Aiassa, F. Criscuolo, F. Stradolini, I. Tzouvadaki, S. Carrara, and D. Demarchi, "New approach for making standard the development of biosensing devices by a modular multi-purpose design," *IEEE Transactions on NanoBioscience*, vol. 19, no. 3, pp. 339–346, 2020.
- [16] F. Stradolini, T. Kilic, A. Di Consiglio, M. Ozsoz, G. De Micheli, and S. Carrara, "Long-term monitoring of propofol and fouling effect on pencil graphite electrodes," *Electroanalysis*, vol. 30, no. 7, pp. 1363–1369, 2018.
- [17] C. A. Knibbe, K. P. Zuideveld, L. P. Aarts, P. F. Kuks, and M. Danhof, "Allometric relationships between the pharmacokinetics of propofol in rats, children and adults," *British journal of clinical pharmacology*, vol. 59, no. 6, pp. 705–711, 2005.
- [18] A. J. Bard, and L. R. Faulkner, *Electrochemical Methods: Fundamentals and Applications*. New York: Wiley, 2001.
- [19] F. Stradolini, T. Kilic, I. Taurino, G. De Micheli, and S. Carrara, "Cleaning strategy for carbon-based electrodes: Long-term propofol monitoring in human serum," *Sensors and Actuators B: Chemical*, vol. 269, pp. 304–313, 2018.