

Internal fixation of femur fractures: a new wireless electromechanical dynamization system

Original

Internal fixation of femur fractures: a new wireless electromechanical dynamization system / Dichio, Giancarlo; Putame, Giovanni; Terzini, Mara; Cannata, Sergio; Costa, Piero; Pasero, Eros Gian Alessandro; Audenino, Alberto. - (2020). (Intervento presentato al convegno Seventh National Congress of Bioengineering tenutosi a Trieste (ITA) nel 9 - 11 June 2021).

Availability:

This version is available at: 11583/2846125 since: 2020-10-06T10:41:42Z

Publisher:

Pàtron

Published

DOI:

Terms of use:

This article is made available under terms and conditions as specified in the corresponding bibliographic description in the repository

Publisher copyright

(Article begins on next page)

Internal fixation of femur fractures: a new wireless electromechanical dynamization system

G. Dichio^{1,3}, G. Putame^{1,3}, M. Terzini^{1,3}, S. Cannata^{2,3}, P. Costa⁴, E.G. Pasero^{2,3} and A.L. Audenino^{1,3}

¹ Department of Mechanical and Aerospace Engineering, Politecnico di Torino, Turin, Italy ² Department of Electronics and Telecommunications, Politecnico di Torino, Turin, Italy, ³ Polito^{BIO}Med Lab, Politecnico di Torino, Turin, Italy, ⁴ Intrauma S.p.A., Rivoli, Italy

Abstract – Dynamization of fracture fixation is an important strategy to reduce the time of recovery for a patient. The principal aim of this treatment is to stimulate the proliferation of callus in the early phase of recovery and to accelerate the new bone formation. External stabilization is a gold standard technique for this type of treatment, but internal fixation has recently gained increasing attention. In this framework, the here introduced dynamization system has been developed for the treatment of polytraumatized patients, who would benefit from the fast recovery guaranteed by a minimally invasive technique and by the elimination of the need for re-intervention. Indeed, thanks to an innovative concept, an electromechanical wireless system has been developed in order to accomplish in a simple outpatient intervention the unlocking of the axial load from static to dynamic mode.

Keywords – plate dynamization, wireless systems, femur fractures, internal fixation

I. INTRODUCTION

FRACTURES of the lower limbs, including the long bones Tibia and Femur, represent approximately the 28.5% of total body fractures, which is estimated to be equivalent of about 300,000 cases per year in the only United States. These injuries can be frequent in all age groups and are the consequence of traumatic events occurred in the context of road accidents or falls from high heights. Furthermore, those so-called "high energy" trauma can occur as isolated lesions or associated with other lesions in poly-traumatized patients.

The main purpose of the fracture treatment with a medical device is to ensure stable support to the bone during the healing phase, and to allow the patient to walk as soon as possible. To reduce even more the time of recovering, a new concept of axial dynamization has been recently investigated in the treatment of long bone fractures [1]. Axial dynamization is a condition of fracture stabilization in which the fixation allows unrestricted axial loading by muscle contraction and physiologic weight bearing, whilst bending and rotational loading remain controlled [2]. The effect of dynamization on fracture healing are both the stimulation of the proliferation of the periosteal callus in the early phase and second the acceleration of the remodelling and hypertrophy response of normal bone cells late in the healing phase [3].

External fixation has been in the past an ideal means of applying axial dynamization, since a telescoping frame mechanism can be used to control rotational and bending forces yet allowing free axial compression of the fracture when physiologically loaded. External fixation still remains the best choice for the initial stabilization of fractures with

severe soft tissue injuries and poly-traumatized patients [4].

Nevertheless, for long bone fractures the best choice is internal stabilization, which is based on the following principle of internal fixation: (1) stabilization with inter-fragmentary compression by means of screws and/or plates, which guarantees absolute stability and brings bone to direct healing; (2) the immobilization of a fracture with nailing or with a bridge plate, which provides a less rigid fixation, and provides for the consolidation of the bones with indirect healing through the formation of the callus [5]. In particular, the bridge plate technique is indicated in comminute long bone fractures affecting the proximal or distal growth area, since the intervention can be done with a minimally invasive technique using a percutaneous approach, despite reduction with closed manoeuvres remains still an important problem [6].

Following those principles, the new device here presented allows for an initial implantation of the device in "static" mode and a subsequent unlocking of a sliding support, in a completely non-invasive mode. Indeed, thanks to a wireless activation, the two device components mutual sliding can be un-locked during a simple outpatient intervention, thus allowing dynamic sliding and early healing. In this way, it will be possible to treat complex cases of poly-traumatized patients with major lower limb problems in a single session, without having to provide for further surgery.

II. MATERIALS AND METHODS

A. Plate design

Unlike the dynamic bridge plates currently on the market, in which the release is carried out by activating a screw during a second surgery, the here proposed bridge plate replaces the screw connecting the two mutually sliding parts with a electromechanical (EM) mechanism, able to dynamize the plate in a completely non-invasive way.

Following a standard CAD process, the plate physical structure has been iteratively modelled and dimensioned in order to resist the standard physiological loads. For the structural project requirements, all the geometries have been simulated using traditional FEA procedure, in order to accomplish a predefined structural rigidity of the final design.

Furthermore, to study the influence of the friction, as well as the geometry of the unlocking mechanism, a simplified multi-body model has been created and simulated too, representative of the main study parameters.

B. Design requirements

In addition to structural requirements, other important design input for the physical realization of device were related to the geometry size and integration of preselected electrical components. Those are, in order of importance:

- The final concept must have only one free degree of freedom, while the others needs to be “locked”, i.e. supported by the metallic structure;
- The final dimension of the device should be on the order of a standard femoral plate, which are near to 210 x 25 x 10 mm considering length x width x height;
- The unlocking force needs to be minimal, since the device is intended to be implanted into the body, and the mechanical power is limited by the small dimension of the possible actuation system.

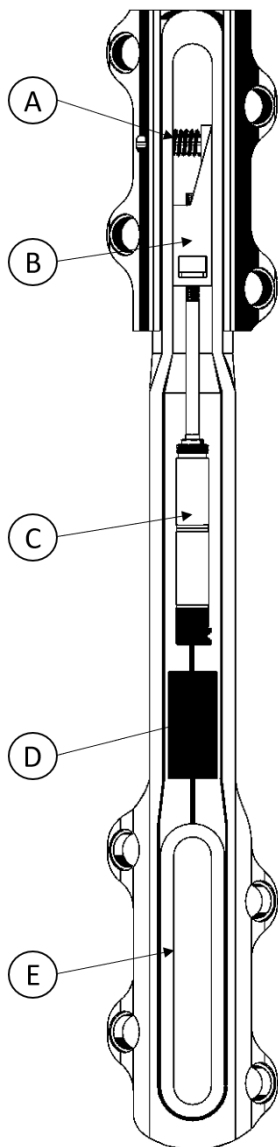

Fig. 1: Detail of the internal actuation system of the plate: A. pin; B. wedge-shape block; C. brush motor; D. receiver circuit; E. receiver coil.

III. RESULTS AND DISCUSSION

A. The unlocking mechanism

Following the design requirements, the unlocking mechanism has been developed consisting of two perfectly complementary metallic parts, designed and sized so that they can relatively slide (Fig. 1, part A-B).

Moving in order with respect to the configuration shown, the first part (the pin - denoted by A) was conceived as a prismatic base with a triangular shape and a semi-circular extension.

The angle of the pin base was initially presumed from the theoretical friction coefficient of the surfaces in contact, as will be detailed in the next section. The section of the semi-circular extension was defined thanks to structural calculations as an ellipse whose larger radius is equal to 3.5 mm, in order to guarantee his structural resistance especially in the initial phase of loading, when the plate is in “static” mode. The function of the pin is ensuring the initial locking between the two mutually sliding parts of the plate, ensuring the structural resistance of the construct when is locked, as shown in Figure 2. To facilitate the pin release and minimize the forces involved, the pin is wrapped by a preloaded spring, which when released moves the pin inside the plate, thus unlocking the system.

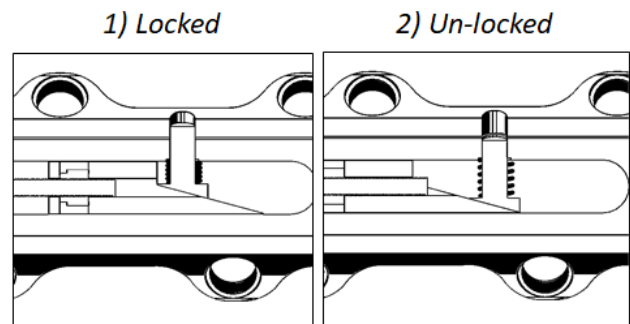

Fig. 2: Detail of the locking mechanism in the locked (1) and un-locked (2) configurations.

The second of the two parts (the wedge-shape block - denoted by B) was conceived as a rectangular block with a terminal part of triangular shape. The angle of inclination is the same of the pin base, in order to perfectly slide each other. It has also a central hole used for the passage of the worm screw, and a recess used to host the nut of the EM actuation system.

B. Angle optimization

For the correct sizing of the unlocking mechanism components, the main parameter is the angle of friction at which the preload of the spring is exactly balanced by the resistance of the plane (the component of horizontal force due to friction). This angle depends on several parameters, but the most important are, by literature, the pair of materials in contact, the surface finishing conditions, and the presence of lubrication. So, it can be strictly related to the physical process that has been selected to produce the components but can also be determined by the presence of different materials or lubricant interposed between the two surfaces. In order to

study his influence on the axial force acting on the motor, a simple multi-body system has been developed taking into account the main physical and geometrical parameters of the systems, which are also highlighted in the following expression:

$$Fa = Fn * \mu = Kp * \cos(\varphi) * tg(\varphi) = Kp * \sin(\varphi) = Fp \quad (1)$$

Where: Fa is the friction force parallel to the plane; Fn is the component of the force, normal to the plane; μ is the friction coefficient between the surfaces; Fp is the component of the force, parallel to the plane; Kp is the spring preload and φ is the inclination angle of the pre-defined geometry.

As shown in equation (1), the selection of an angle of inclination exactly equal to the friction angle, i.e. $\mu = tg(\varphi)$, transform the relation in an identity, since Fa will be exactly equal to Fp . In this condition, the initial force resultant on the block will be zero.

In our case, since we want to obtain a relative sliding of the un-locking mechanism with the application of a very small force, it is important to choose an angle of inclination as close as much to the theoretical friction angle between those two surfaces, or at least over dimension it of a small quantity in order to have a positive force instead of negative one.

A lists of the standard friction coefficients used to simulate the contact problem into the multi-body model is shown in Table 1.

TABLE I
MATERIAL FRICTION PROPERTIES

Materials	μ_s : static coefficient	μ_d : dynamic coefficient
Greasy aluminum – Dry steel	0,30	0,20
Greasy aluminum – Greasy steel	0,23	0,16
Greasy steel – Dry/Greasy steel	0,23	0,16
Acrylic – Dry/Greasy steel	0,20	0,15
Nylon – Dry/Greasy aluminum	0,10	0,06
Nylon – Acrylic	0,10	0,06
Nylon – Nylon	0,10	0,06

Principal friction coefficient usually utilized for multi-body modelling of contact problems.

Because the physical value can slightly differ from the values obtained by theoretical equations, due to possible tolerances of the physical process, an experimental testing on the unlocking mechanism is fundamental.

C. Electromechanical actuation

For the actuation of the wedge-shape block, a preassembled motor reduction system has been selected (Fig. 1- part C).

This is composed of a three sub-block which are: (1) a DC motor; (2) a planetary gear's reduction mechanism, which

can have from 1 to 5 stages of reduction depending on the outer torque and velocity we need; (3) a metric screw drive, which can have different lengths and nuts, depending on the application and efficiency needed.

Taking into account the design constraints, the following combination was selected:

- RE6 DC motor, Φ 6mm, precious metal brushes, 0.3 W of nominal Power, and 4.5 V of nominal tension;
- GP6S screw driver, Φ 6mm, composed of a Planetary gearhead with 3 or 4 stages of reduction, and a metric lead screw with standard length of 45 mm.

The main advantages of brush motors are their relative cheapness with respect to the brushless ones, the simplicity of the regulators that must pilot them and the prompt response to commands at low revs and when stationary.



Fig. 3: The metal brush motor with the 4 stages gear reduction system and the preselected screw drive in the assembled configuration.

D. Electrical power supply

In order to supply power to the motor, an inductive power transfer system has been conceived, consisting of two magnetically coupled coils. The voltage supply – namely 4.5 V - is applied to the transmitting coil and the related power is transferred to the receiver side (Fig. 1 – part E), to which a supercapacitor is connected. The charge stored into the supercapacitor is then used to supply power to the electric motor, which will start to rotate, thus making the pin retract.

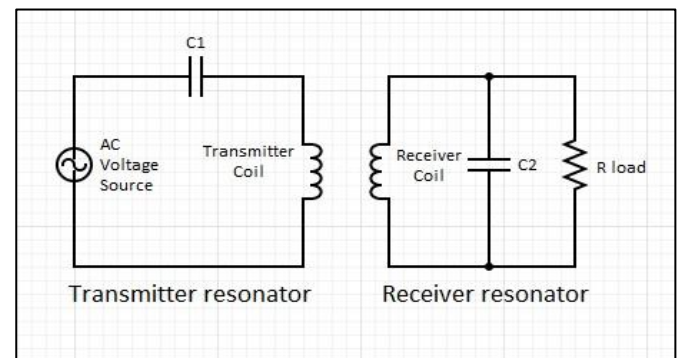

Fig. 4: Schematic of simplified circuit.

The equivalent circuit can be depicted as shown in Figure 4, where $C1$ and $C2$ capacitors are deployed in order to implement a resonating system, thus maximizing the power transfer. A different view of the same topology is shown in Figure 5, highlighting resistive losses in both sides of the system, as well as the supercapacitor (indicated as C_{sup}) [7].

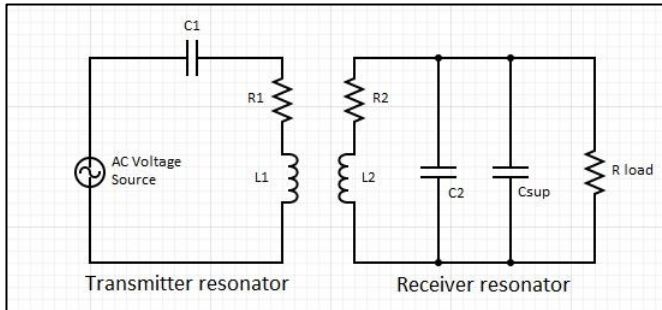

Fig. 5: Inductive power transfer circuit with supercapacitor.

The fundamental electrical components needed for the implementation of the physical circuit are:

- 1 transmitter coil;
- 1 receiver coil;
- 1 supercapacitor;
- 2 capacitors to set the resonance condition;
- 1 voltage supply for the transmitter side.

One of the main design constraints to consider must be the size and geometry of the receiver coil, which should be small enough to be hosted on the plate, yet big enough to receive enough power to supply the motor. For this reason, a Printed Circuit Coil (PCC) like the one shown in the Figure 6 could be used. Moreover, additional components might be necessary to convert voltages from DC to AC on the transmitter side – and vice versa on the receiver side – making the power transfer to work in a proper manner.

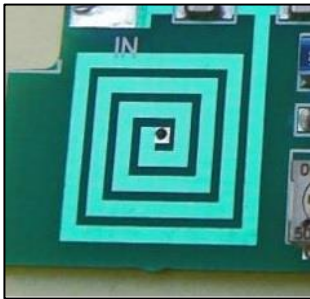

Fig. 6: Printed Circuit Coil.

Finally, for a safe feedback to the medical doctor, might be also worth to take into account a feedback element able to sense if the pin has completed its motion – e.g. a switch that closes at the pin motion end.

IV. CONCLUSION

The dynamization system here presented resulted feasible in all the technical aspects, both from the electrical and from the mechanical point of view. An electromechanical unlocking mechanism has been developed which, by using the transfer of energy from the outside to the inside of the body by means of two inductors, allows the recharging of a super-capacitor whose energy is used to activate a DC motor. The motor, directly connected to a motion reduction mechanism, manages to axially move a wedge-shaped block which activates the retraction of the pin. The next step of this work will be the physical realization of the components and the testing of the critical parts, in order to verify the fulfilment of all the predefined design requirements.

ACKNOWLEDGEMENT

A thanks for the realization of this project, is going to W.D.Plate – P.O.R. FESR 2014-2020 Piemonte – “Poli Innovazione Linea A”.

REFERENCES

- [1] E. Egger, F. Gottsauner-Wolf, et al., “Effect of axial dynamization on bone healing”, *The journal of trauma*, vol. 34, no. 2.
- [2] T. Yamaji, K. Ando, et al., “The effect of micromovement on callus formation”, *Journal of Orthopaedic Science*, (2001) 6:571-575;
- [3] M. Foxworthy and R.M. Pringle, “Dynamization timing and its effect on bone healing when using the Orthofix Dynamic Axial Fixator”, *Injury* vol. 26, no. 2, pp. 117-119, 1995;
- [4] L.E. Claes, H-J. Wilke, et. Al., “Effect of dynamization on gap healing of diaphyseal fractures under external fixation”, *Clinical Biomechanics*, vol 10, n.5, pp. 227-234, 1995;
- [5] C. Sommers, T. Ruedi, “Fissazione interna delle fratture”, *Tecniche chirurgiche in ortopedia e traumatologia*, 01-01-210.
- [6] S. Larsson, W. Kim, et. Al, “Effect of early axial dynamization on tibial bone healing”, *Clinical orthopaedics and related research*, n. 388, pp. 240-251;
- [7] Y. B. Fadel, S. Ktata et al., “A Modified Wireless Power Transfer System for Medical Implants”, *Energies* 12(10):1890, May 2019;