

Enhancing operational performance of AHUs through an advanced fault detection and diagnosis process based on temporal association and decision rules

Original

Enhancing operational performance of AHUs through an advanced fault detection and diagnosis process based on temporal association and decision rules / Piscitelli, M. S.; Mazzarelli, D. M.; Capozzoli, A.. - In: ENERGY AND BUILDINGS. - ISSN 0378-7788. - STAMPA. - 226:(2020), p. 110369. [10.1016/j.enbuild.2020.110369]

Availability:

This version is available at: 11583/2842789 since: 2020-08-20T12:38:18Z

Publisher:

Elsevier Ltd

Published

DOI:10.1016/j.enbuild.2020.110369

Terms of use:

This article is made available under terms and conditions as specified in the corresponding bibliographic description in the repository

Publisher copyright

Elsevier postprint/Author's Accepted Manuscript

© 2020. This manuscript version is made available under the CC-BY-NC-ND 4.0 license
<http://creativecommons.org/licenses/by-nc-nd/4.0/>. The final authenticated version is available online at:
<http://dx.doi.org/10.1016/j.enbuild.2020.110369>

(Article begins on next page)

Enhancing operational performance of AHUs through an advanced fault detection and diagnosis process based on temporal association and decision rules

Marco Savino Piscitelli^a, Daniele Mauro Mazzarelli^a, Alfonso Capozzoli^{a*}

^a *Dipartimento Energia "Galileo Ferraris", Politecnico di Torino, Corso Duca degli Abruzzi 24, 10129 Torino, Italy*

* Corresponding author: Tel: +39-011-090-4413, fax: +39-011-090-4499, e-mail: alfonso.capozzoli@polito.it

Abstract

The pervasive monitoring of HVAC systems through Building Energy Management Systems (BEMSs) is enabling the full exploitation of data-driven based methodologies for performing advanced energy management strategies. In this context, the implementation of Automated Fault Detection and Diagnosis (AFDD) based on collected operational data of Air Handling Units (AHUs) proved to be particularly effective to prevent anomalous running modes which can lead to significant energy waste over time and discomfort conditions in the built environment. The present work proposes a novel methodology for performing AFDD, based on both unsupervised and supervised data-driven methods tailored according to the operation of an AHU during transient and non-transient periods. The whole process is developed and tested on a sample of real data gathered from monitoring campaigns on two identical AHUs in the framework of the Research Project ASHRAE RP-1312. During the start-up period of operation, the methodology exploits Temporal Association Rules Mining (TARM) algorithm for an early detection of faults, while during non-transient period a number of classification models are developed for the identification of the deviation from the normal operation. The proposed methodology, conceived for real-time implementation, proved to be capable of robustly and promptly identifying the presence of typical faults in AHUs.

25 **Keywords:** HVAC systems; Air Handling Units; Fault Detection and Diagnosis; Temporal
26 Association Rules Mining; Intelligent energy management

27 **Highlights**

- 28 • A fault detection and diagnosis process is applied on AHU monitoring data;
- 29 • A novel methodology tailored on transient and non-transient operation is proposed;
- 30 • Faults in the transient period are detected with multivariate association rules;
- 31 • Temporal associations are exploited during the start-up period of the system;
- 32 • Decision rules are extracted for fault diagnosis in non-transient regime of AHU;

33 **1 Introduction**

34 Recent years have seen an increasing interest of the scientific community in exploring solutions to
35 improve energy efficiency in buildings by implementing advanced data-analytics based energy
36 management strategies. The application of these strategies is supported by the increasing penetration
37 of ICT (Information and Communication Technologies) and EMSs (Energy Management System) in
38 buildings, which may enable the adoption of data analytics based procedures for the exploitation of
39 collected energy-related data and the extraction of hidden knowledge in an automatic way [1].

40 Building Energy Management System (BEMS) are mainly used for tracking and managing the
41 operation and energy performance over time of Heating Ventilation and Air Conditioning (HVAC)
42 systems. The optimal management of HVAC systems, which accounts in the developed countries for
43 10-20% of the total energy share in buildings [2], is a crucial task, considering that such systems
44 account for 50% of the energy demand in commercial buildings [3].

45 However, due to lack of proper maintenance, failure of components or incorrect installation, Air
46 Handling Units (AHUs) are often run in inappropriate operational conditions. A study conducted on

47 more than 55.000 AHUs, showed that a fraction of 90% of them runs with one or multiple faults [4],
48 where a fault is intended as an abnormal system state, an unpermitted deviation of at least one
49 characteristic property of the system from the acceptable, usual, standard conditions. The
50 identification and diagnosis of faults, in the case of HVAC systems, can lead to potential savings of
51 about 30% [5]. This process is also known as Fault Detection and Diagnosis (FDD) where *fault*
52 *detection* consists in the recognition of a fault occurrence, and *fault diagnosis* corresponds to the
53 identification of the causes and the location of the fault [6]. Advanced methods of *fault detection* are
54 based on mathematical models and on methods of system and process modelling to generate fault
55 *symptoms* (e.g. residuals). *Fault diagnosis* methods use causal fault-symptom-relationships by
56 applying techniques from statistical decision, artificial intelligence and soft computing [6].
57 Although currently underutilized, FDD is a powerful tool for ensuring high efficiency in building
58 operation and FDD products represent a very fast-growing market in the context of building analytics
59 technologies [7]. According to [8], over 30 FDD products are available in U.S. that may be delivered
60 through different implementation models [7]. The algorithms behind FDD tools may be integrated
61 into server-based software, desktop software, or software directly embedded in equipment controllers.
62 FDD algorithms are based on historical data that can be gathered from different sources such as
63 Building Automation Systems (BAS), equipment controllers, external sensors and meters, or mixed
64 sources. Despite the existing differences in the way tools are implemented and integrated with the
65 monitoring system, the main tool classification can be performed according to the approach employed
66 for conducting the FDD analysis.

67 The methods used for performing an FDD analysis can be classified in quantitative model-based,
68 qualitative model-based and data driven-based, as done in [9].

69 The quantitative model-based approach includes all the methods involving engineering models with
70 different levels of detail in the physical description of the system (e.g. white box models). The
71 qualitative model-based methods exploit the system knowledge derived from domain expertise (e.g.
72 rule-based, qualitative models). The last category includes data-driven methodologies exploiting

73 collected operational data of the system under investigation (e.g. Artificial Neural Networks,
74 Association Rules Mining, grey box models). While rule-based methodologies (qualitative approach)
75 are largely used, vendors are beginning to use data driven methodologies for addressing FDD tasks
76 [7].

77 The next section provides an overview of the use of data-driven approach for FDD, with a specific
78 focus to AHU systems.

79 1.1 Data-driven approach for FDD analysis in AHUs

80 In the last few years, the data-driven approach for the FDD analysis gained more and more interest,
81 thanks to its applicability even in the case engineering models of the building and systems are
82 inadequate or difficult to be developed, or the physics-based knowledge is not wide enough [9]. In
83 this context, particularly promising appears the implementation of machine-learning techniques,
84 which include both supervised and unsupervised algorithms. As pointed out in [10], the main
85 advantages of the artificial intelligence-based data-driven approach, in comparison to traditional
86 approaches, rely on the opportunity to:

- 87 • Learn automatically patterns from system operational data without the use of physical models.
88 The data-driven approach does not require an a-priori understanding of the relationships that
89 exist among faults and their symptoms.
- 90 • Achieve higher fault-detection and fault-diagnosis accuracy than qualitative methods (rules
91 based on expert knowledge), also for faults of low severity levels.
- 92 • Perform FDD analysis exploiting a limited number of variables. It means that approach can
93 enable an optimisation of sensor installation and then significantly reduce the number of
94 required sensors.

95 More in detail, the supervised approach uses the domain expertise to develop useful prediction tool,
96 since monitored data include variables for both input and output of the model (i.e. regression or

97 classification methods). On the other hand, the unsupervised methods (e.g., cluster analysis,
98 association-rule mining) are capable to extract hidden knowledge without a pre-defined target (i.e.
99 data used do not have any output values) and are particularly effective in case of poor-information
100 systems or when the objective of the analysis is not a-priori constrained [11].

101 The methods involving the construction of supervised estimation models mainly consider the
102 implementation of a residual analysis in order to perform an FDD process. The residual in that context
103 is the difference between the estimated and the measured value of a specific target variable: the
104 estimation is performed by means of a fault-free supervised model, while actual data may be related
105 to faulty conditions. Therefore, the residual analysis is used as a way for assessing the severity of the
106 deviation from the fault-free conditions during operation [12].

107 Many applications of supervised and unsupervised techniques for Automated Fault Detection and
108 Diagnosis (AFDD) are reported in literature, particularly for detecting faults during the non-transient
109 operation of AHUs [13].

110 Even though each component of an AHU can be potentially corrupted by a fault, the most common
111 faults can affect sensors (e.g. offset in the measurement), controlled devices (e.g. blockage or leakage
112 of air damper or coil valves), equipment (e.g. coil fouling or reduced capacity, duct leakage, fan
113 complete failure or deviation in the pressure drop or belt slippage) and controllers (e.g. unstable or
114 frozen control signal for dampers, coils or fan) [14]. In [15] was proposed a methodology to identify
115 faults related to the fans and the air dampers of an AHU. The methodology uses a Multi-Class Support
116 Vector Machine (MC-SVM), for the identification of both pre-labelled faults and new ones. In [16]
117 and [17], a Bayesian Network (BN) was adopted for the diagnosis of faults related to air dampers,
118 cooling coil valve stuck and return fan failure. The BN exploited in input the residuals obtained from
119 a set of limit-checking rules and statistical models, capable of estimating air temperature, water flow
120 rate, air flow rate and fan power consumption. Mulumba et al. proposed in [18] a methodology to
121 diagnose the presence of several faults affecting air dampers, cooling coil valve and return fan by
122 using a SVM in combination with an autoregressive model with exogenous inputs. Yan et al. proposed

123 in [19] a combination of two supervised techniques to diagnose the blockage of air dampers and coil
124 valve, the duct leakage and the return fan failure. In [19] a Classification Tree (CT) was developed,
125 which used in input both monitored data (i.e. air temperature and flow rate, fan speed and power, and
126 cooling coil valve position) and residuals obtained from a regression model of the fan speed, while
127 in output the labels of different faults were considered. The methodology developed in [19] made it
128 possible to accurately perform fault diagnosis, but without taking into account transient periods of
129 operation. Different classification models for fault detection were also compared in the work of
130 McHugh et al. [20] and the Classification (decision) Tree model was selected as the best choice for
131 the detection of steam or chilled water leakage.

132 The unsupervised methods proved to be particularly flexible for their nature in exploring data set
133 without any *a priori* constraint, as opposed to the supervised models [11].

134 Yu et al. proposed in [21] an unsupervised methodology to identify energy wastes and faults of a fan
135 in an AHU, by exploiting Association Rules Mining (ARM). This type of algorithm requires a strong
136 expertise by the analyst for the interpretation of the results, considering that the rule set extracted
137 could include also not-interesting information for the identification of anomalous operation of the air
138 conditioning system [21]. Many studies make use of ARM for the identification of faults in different
139 types of HVAC systems (e.g. district heating substation, AHU, chillers)[10]. ARM has been adopted
140 also for the analysis of a district heating substation in order to identify inefficient operation and sensor
141 faults by searching anomalous correlation expressed by association rules [22]. In order to help the
142 domain expert in the interpretation of the results, in [23] a methodology was proposed to reduce the
143 number of rules to be analysed and to effectively group them for distinguishing the faulty from the
144 normal operation. Furthermore, the temporal relation among the energy consumption of different
145 HVAC components was studied in [24] and [25] to determine the presence of faults and prevent a
146 reduction of energy performance over time.

147 A combination of a supervised and unsupervised methods (e.g., decision tree and clustering analysis)
148 was proposed in [26] and [27] for the detection of anomalous energy consumption in a group of smart

149 office buildings. Furthermore, Dey et al. achieved in [28] high values of accuracy in the automatic
150 FDD on fan coil units operation by combining MC-SVM and cluster analysis.

151 Du et al. in [29] proposed a methodology to identify faults of temperature, flow rate and pressure
152 sensors in a VAV system by implementing Artificial Neural Networks (ANNs) in combination with
153 a signal decomposition technique (i.e. Wavelet analysis). In [30], an ANN was combined with
154 clustering analysis to diagnose faults related to cooling coil valve, air damper and temperature sensors
155 in an AHU. In the first step, the ANN was used for the estimation of supply air and water temperature
156 to perform a residual analysis, then the methodology leveraged on clustering analysis for the fault
157 diagnosis stage. Guo et al. used a Hidden Markov Model (HMM) for the fault detection phase and a
158 cluster analysis for the identification of various types of faults such as the blockage of dampers, frozen
159 fan or unstable cooling coil valve control signal [31]. In [32] and [33], an unsupervised data-driven
160 approach was used to identify the presence of cooling coil valve blockage, heating coil valve leakage
161 and air damper blockage, by analysing the error generated from the reduction of variables by means
162 of Wavelet Transform and Principal Component Analysis. Successively, the fault diagnosis was
163 performed by analysing the trend of each variable during faulty conditions, in order to identify the
164 variable mostly influenced by the fault source.

165 Liang et al. in [34] proposed a methodology to diagnose the stuck of the recirculation damper and of
166 the cooling coil valve in an AHU, as well as the decreasing of the supply fan speed. In that work, an
167 SVM was used in combination with a white box model, exploiting the residuals obtained by
168 comparing actual and simulated fault-free values of supply and mixed air temperature, and cooling
169 coil outlet water temperature. Wu et al. in [35] combined a quantitative model-based method with an
170 unsupervised data-driven method to diagnose sensor faults, air damper blockage or frozen fan. In that
171 work, first the variables considered were reduced (i.e., by means of Principal Component Analysis),
172 then the presence of faults was investigated comparing actual monitored data with the estimation of
173 airflow rate and energy calculated by using simplified balance equations for energy and pressure-
174 flow. In other works, a qualitative-based approach was used to perform automatic FDD in

175 combination with the data-driven approach. In [36], the detection of faults occurring in an AHU was
176 performed by exploiting “IF-THEN” expert rules related to the residuals of mixed air temperature,
177 return air flow rate, supply air static pressure and cooling coil valve control signal, generated with
178 different General Regression Neural Networks. In [37] the integration of expert rules with Bayesian
179 Networks was pursued, in order to better isolate faults in AHU. Such approach made it possible to
180 exploit the violation of expert rules, to better detect the co-occurrence of multiple faults at the same
181 time.

182 The above reported literature review demonstrated how much the scientific research has been active
183 in the field of artificial intelligence for FDD in AHU and HVAC systems. However, the opportunity
184 to approach this well-known task (i.e., FDD) from this innovative point of view was mainly due to
185 the growing availability of huge amount of monitored data, related to the actual performance of
186 buildings and energy systems. In this context some projects, supported by the American Society of
187 Heating, Refrigerating and Air- Conditioning Engineers (ASHRAE) made very comprehensive field
188 surveys, laboratory tests and performance evaluations on the performance of HVAC systems also in
189 faulty conditions. The outcomes of such projects (e.g., ASHRAE Project 1312-RP and 1043-RP)
190 enabled a great spread of FDD methodologies which exploit experimental data.

191 Among the reviewed papers, several published studies focused on the ASHRAE RP-1312 data set for
192 developing and testing FDD methodologies for AHUs [16,17,38–43]. Despite those papers discuss
193 the results of FDD methodologies on the same data set, not always the assumptions behind the
194 analysis are the same. The main differences are related to the operation mode considered (cooling,
195 heating, spring), the number and the type of faults analysed, the regime of operation considered
196 (transient, non-transient). However, from the analysis of these works, some general considerations
197 can be made:

- 198 • In most of the cases the analysis is performed for the summer period achieving high values of
199 accuracy in diagnosing faults (over 90% of accuracy),

- 200 • The analysis is performed for data collected with sampling frequency of 1-min (original
201 granularity of the dataset),
- 202 • Data-driven models used for characterizing the normal behaviour of the AHU lack of
203 interpretability (SVM, ANN)
- 204 • In most of the cases, the fault diagnosis is performed through interpretable classifiers (decision
205 trees, Bayesian networks).

206 In this context, the present paper aims at introducing an FDD methodology for AHU systems (based
207 on data of ASHRAE RP-1312) that is data-driven, fully interpretable and rule-based. Indeed, the rule-
208 based approach can satisfy the user need of simplicity and interpretability while the data-driven nature
209 of the methodology can enable the automatic learning of system operational patterns. Another
210 objective is also to reduce the granularity of the dataset while maintaining good performance in fault
211 diagnosis. In fact, analyse data with a high sampling frequency could expose the FDD tool to
212 instabilities when deployed for operating in real time (presence of punctual anomalies, missing
213 values, sensor network latency).

214 In the approach proposed in this paper two rule-extraction methods (association rule mining, decision
215 tree) were employed for conducting FDD analysis in AHU system, by exploiting the reduction and
216 transformation of multiple time series related to the operation variables of the system. In the next
217 section a discussion is provided about the automatic extraction of rules in multiple time series (Section
218 210) and the work novelty is explained (Section 2.1); the case study analysed in the paper is presented
219 in Section 3; a focus on data analysis methods exploited in the analysis is provided in Section 4 and
220 a description of the proposed methodology is provided in Section 5. In Section 6, the results obtained
221 from the application of the methodology are presented. Eventually in Section 7 the discussion of
222 results and concluding remarks are provided.

223 **2 Rule extraction in multiple time series for FDD in AHUs**

224 The analysis reported in section 1.1 on the most relevant works published in the last few years,
225 showed how FDD strategies in AHUs can widely benefit from the implementation of data mining and
226 machine learning techniques, especially when they are supported by a robust expertise in building
227 physics for an effective exploitation and interpretation of the extracted knowledge. However, the
228 complexity of an AHU with multiple operational parameters and the temporal interactions among
229 them makes the effective characterisation of its behaviour challenging.

230 The operation of an AHU system is characterized by two major time-regimes, namely transient and
231 non-transient. The transient operation typically occurs when the AHU is started-up and is approaching
232 the steady state conditions, or when it is shutdown or disturbed from its non-transient regime. The
233 disturbances could be caused by either variation of thermal loads or by feedback controls. During
234 transient periods some variables can exhibit strong variation in short time and a significant temporally
235 lagged response with respect to the control signals. In addition, the behaviour of an AHU system
236 varies as its mode of operation changes during the day and the year i.e., off mode, heating mode, free
237 cooling mode, and cooling mode. Therefore, a robust data-driven-based FDD tool should be able to
238 automatically determine the mode of operation of the system, to prevent false alarms from being
239 generated. For example, normal behaviour during summer season may be faulty if the system is
240 operating in heating mode (winter season). In order to avoid that condition, FDD tools in AHU
241 systems are characterized by a hierarchical architecture that makes it possible to exploit only the
242 portion of knowledge that is consistent with the specific operation mode considered. In this
243 perspective, when using data-driven based FDD tools it is necessary for the training data to be
244 exhaustive as possible for each operation mode.

245 However, given their complexity, data-driven-based FDD tools often lack in interpretability. In this
246 context, the use of rule-based data-driven methods for FDD can satisfy the user need of simplicity in
247 terms of understanding the FDD tool, using, commissioning and integrating it with existing BAS, and
248 updating it. For this reason, great attention has been paid in this study to the application of advanced

249 supervised and unsupervised rule extraction methods (i.e., decision trees, association rule mining)
 250 with reference to multivariate problems.

251 The operation of an AHU is a perfect case that can be effectively described through the analysis of
 252 multiple time series (defined as series data points indexed in time order) associated to each operational
 253 variable of the system. However, the large number of time series with high sampling frequency could
 254 significantly increase the complexity and computational cost of the analysis, often making necessary
 255 a proper reduction (aggregation in the time domain) and discretization (quantization of the signal
 256 value) of data. This is a challenging task, considering that each variable has its own behaviour and
 257 distribution and, as a consequence, the optimal time aggregation and value discretization of the signal
 258 need to be identified with the aim of minimizing the information loss and of maximizing the mining
 259 performance. Such preparation of the time series is an essential step in FDD methodologies based on
 260 rule extraction techniques (e.g., based on association-rule mining algorithms or decision trees) that,
 261 in the literature, have been used for effectively mining co-occurrences or implications between
 262 discrete values and events in the time domain during HVAC operation [19,24,44].

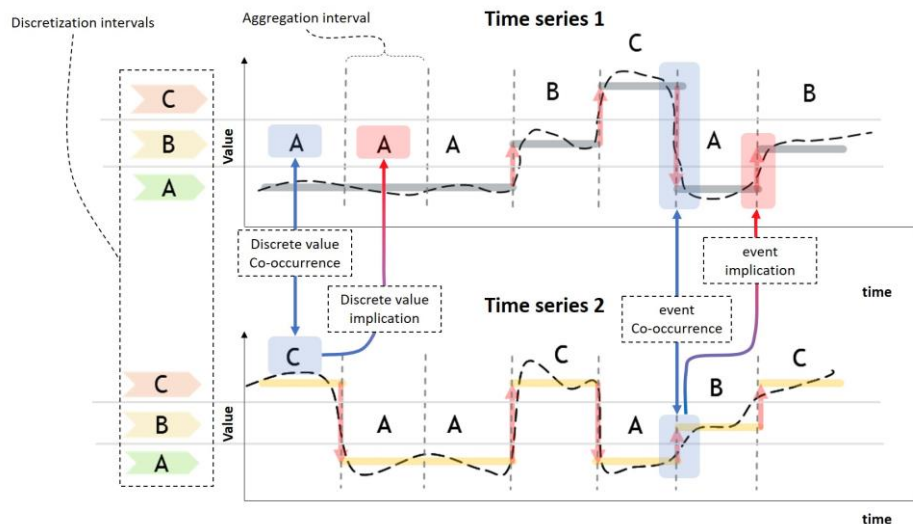

263
 264 *Figure 1. Graphical representation of co-occurrence and implication between discrete values and events among*
 265 *multiple time series.*

266 Figure 1 depicts in graphical form the concepts, of discrete value, event (change of discrete value
 267 between two contiguous aggregation intervals), co-occurrence and implication of discrete values and

268 events with reference to two time series encoded in symbols by means of Symbolic Aggregate
269 approxXimation (SAX) [45].

270 When multiple time series are considered, rule extraction techniques can be categorized in intra-
271 transactional and inter-transactional respectively. The first type of extraction aims at discovering co-
272 occurrences between discrete values and events that frequently happen at the same time among
273 different time series (Figure 1). The second type of rule extraction is more complex, considering that
274 the occurrences of discrete values and events among different time series, in that case, are searched
275 taking into account the existence of a time lag (Figure 1). During transient periods of AHUs operation,
276 the latter approach is particularly favourable in describing phenomena that are characterized by
277 temporal dependences among variables representative of the system operation (e.g., change of status
278 in a fan speed and the corresponding effect on supply air temperature).

279 In order to develop an FDD process capable to be flexible in relation to different conditions of
280 operation in AHUs, the present study proposes the application of two rule extraction methodologies
281 tailored for both transient and non-transient periods.

282 The developed framework aims at preventing anomalous running modes of AHUs, which could lead
283 to significant energy waste over time and/or discomfort conditions in the built environment.

284 The analysis relies on temporal abstraction as a pre-processing stage. Temporal abstraction is aimed
285 at reducing and transforming time series in discrete-time and discrete-value signals through
286 aggregation on the time axis and discretization of the value in order to perform the extraction of
287 interesting co-occurrences and implications. In this study, an adaptive process based on a Symbolic
288 SAX is employed for conducting the temporal abstraction.

289 Furthermore, strong relations between events (i.e., change of discrete value between contiguous
290 aggregation intervals) are automatically mined by means of temporal IF-THEN association rules in
291 the transient period of AHU operation (i.e., start-up phase), considering an intra-transactional
292 approach for characterizing the fault-free behaviour of the system. Similarly, during the non-transient
293 period of operation, a set of classification trees are developed for extracting reference patterns in the

294 form of decision rules. Potential faulty conditions are then detected when the discovered association
295 and decision rules are violated over time. Successively, the identified anomalous patterns (during the
296 non-transient period) are exploited for performing a diagnosis of the most probable faults associated
297 to a specific kind of rule violation by means of a classification algorithm.

298 2.1 Novelty of the paper

299 The present work introduces an automatic methodology for performing an FDD analysis in AHUs by
300 using experimental data obtained in the framework of the ASHRAE project RP-1312. The entire
301 process relies on the application of data mining-based algorithms in order to develop a tool capable
302 to detect and diagnose operational faults in AHUs which can determine energy waste over time and
303 the occurrence of discomfort conditions in the built environment.

304 Based on the FDD literature review presented in section 1.1, the main innovative aspects introduced
305 by the present paper are the following:

- 306 • An adaptive process of data reduction and transformation is employed to develop a robust
307 FDD methodology. In complex systems as AHUs, the number of monitored variables and
308 their sampling frequencies could be very high. Extracting only key information from large
309 data set is essential for reducing redundancy, complexity and computational cost. In this study,
310 the methodology makes it possible to achieve good performance in FDD (comparable to other
311 studies focused on the same dataset [16,17,38–43]) leveraging only on the analysis of
312 significant discrete intervals of the operational variables over time.
- 313 • The start-up period of AHU operation is isolated and treated separately by developing a
314 tailored analytics module (instead of being filtered out as happened in other studies focused
315 on the same dataset [16,17,38–43]). During transient period of operation time lags occur for
316 example between a change of status in the fan speed and the corresponding effect on supply

317 air temperature. For this reason, temporal association rules are extracted, following an intra-
318 transactional approach, for discovering associations between events during transient periods,
319 across multiple time series, that frequently occurs within a time lag.

- 320 • The characterization of normal behaviour during the non-transient period is completely
321 automated and performed by using a set of estimation models based on decision trees. In
322 comparison to other studies focused on the same dataset [16,17,38–43], the reference
323 behaviour of the AHU is evaluated estimating the most probable discrete value of each
324 influencing operational variable in relation to all the others monitored. In that way, all the
325 existing relations between variables are exploited through several estimation models, for
326 detecting potential faulty conditions. Such approach exhibits high flexibility and
327 generalizability in the formulation of the FDD problem.
- 328 • A fault diagnosis during non-transient period of AHU operation is performed by employing a
329 decision tree, capable to extract rules for the classification of typical faults. The diagnosis
330 process exploits the residuals evaluated by means of a set of estimation models as input
331 attributes for the classification of the most probable faults.

332 In that perspective, this study was aimed at conceiving, developing and testing a methodological
333 framework that introduces the aforementioned novelties in automatic FDD, in as robust a way as
334 possible. As previously stated in the literature review, several studies considered the RP-1312 data
335 set in the analysis, achieving an accuracy in fault diagnosing over 90%. As a consequence, the main
336 objective of this study is not to improve the (already high) FDD performance achieved on the RP-
337 1312 dataset, but rather to demonstrate the opportunity to achieve high performance as well through
338 a fully interpretable and simplified data-driven approach, based on rule extraction techniques.

339 **3 Case study**

340 In order to test the validity and the effectiveness of the proposed methodology, operational data
341 related to two AHUs collected in the framework of the Research Project ASHRAE RP-1312 [14]

342 were analysed. The system investigated is a Variable Air Volume (VAV) AHU. A VAV system is
 343 able to modulate the air flow rate according to the variation of the building load and it is typically
 344 made up of 4 subsystem controllers, acting on supply air temperature, dampers and valves, supply air
 345 static pressure and return air flow rate. Specifically, the control logic maintains the supply air
 346 temperature set-point acting on damper and valve positions, according to the mode of operation (i.e.
 347 heating, cooling with partial mixing of outdoor air, cooling with 100% of outdoor air, cooling with
 348 minimum outdoor air).

349 Furthermore, also the static pressure of the supplied air and the difference between the supply and
 350 return air flow rate is controlled. The return air flow rate is modulated acting on the mixing dampers
 351 and the return fan speed, while the system maintains the static pressure set point for the supply air.
 352 As a result, the difference between the supply and return air flow rate is kept constant [12].

353 The dataset used in this paper is particularly interesting as it includes several running conditions for
 354 two AHUs in faulty and fault-free operation. The faulty operation was obtained by artificially
 355 implementing a number of different faults. The site, where the monitoring data have been collected,
 356 is a test facility simulating a typical schedule of occupancy in commercial building.

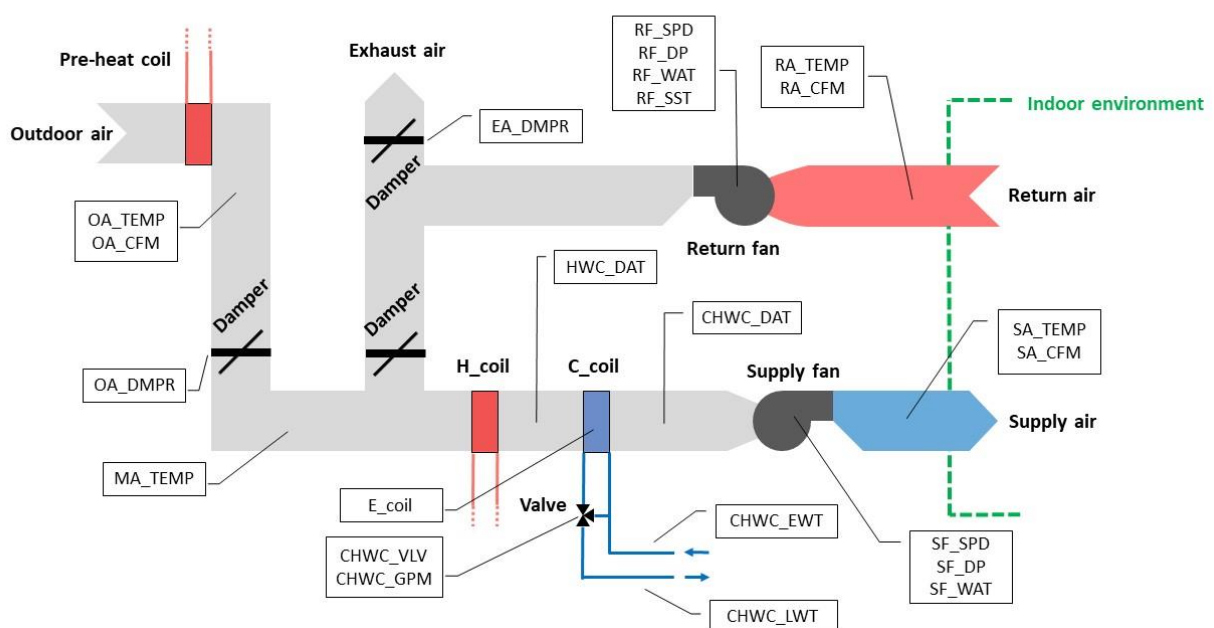

357
 358 *Figure 2. Scheme of the AHU analysed (refer to Table 2 for variable encoding).*

359 The monitoring data were gathered from two AHUs of the facility (AHU-A and B), which are
360 perfectly identical from technical and operational points of view and serve specular zones. The zones
361 served by AHU-A and B face east and west orientation, respectively, in order to be comparable also
362 under the aspect of the thermal loads. The AHUs are characterised by a mixing chamber, to mix return
363 air with outdoor air by means of dampers. Each AHU is equipped with heating and cooling coils and
364 VAV devices to locally adjust the supply air temperature. However, the control volume considered
365 in this work excludes the local VAV devices.

366 Figure 2 shows a schematic configuration of the system with the indication of the monitored variables
367 (a description of the variables is provided in Table 2).

368 In the context of the ASHARE project, a number of different faults were implemented one per time,
369 each for a whole day, only in the AHU-A, in order to analyse independently the effects of each fault.
370 The AHU-B was always run in fault-free conditions to have a reference of the normal operation. The
371 data collection was conducted over three seasons and only the monitoring data of the summer season
372 were considered in this study.

373 *Table 1. Tags and descriptions of faults.*

Fault Tag	Description	Number of days
CCVS15	Cooling coil valve stuck at 15%	1
CCVS65	Cooling coil valve stuck at 65%	1
CCVSFC	Cooling coil valve stuck fully closed	1
CCVSFO	Cooling coil valve stuck open	1
EASFC	Exhaust air damper stuck fully closed	1
EASFO	Exhaust air damper stuck fully open	1
Normal	Normal operation	22
OAS45	Outdoor air damper stuck 45%	1
OAS55	Outdoor air damper stuck 55%	1
OASFC	Outdoor air damper stuck fully closed	1
RFCF	Return fan complete failure	1
RFF30	Return fan at fixed speed (30%)	1

374

375 The dataset consists of multiple time series (one for each monitored variable) with a length of 33 days
376 and a sampling time of 1 minute. In particular, 22 out of 33 days are tagged as fault-free days while
377 the remaining 11 days correspond to different faulty conditions. Table 1 summarizes the number of

378 fault-free and faulty days, the description of each fault and the tags used for labelling each day
 379 included in the monitoring campaign.

380 A feature selection was preliminarily performed on the basis of expert considerations to focus the
 381 analysis only on relevant variables.

382 As a result, the variables considered for the implementation of the FDD methodology are: the
 383 electrical load, the pressure drop and speed of fans, the flow rate and temperature of the air measured
 384 in different parts of the system, the damper position, the valve position, the water flow rate and energy
 385 transferred in the cooling coil.

386 Table 2 reports the list of the 23 variables considered for the analysis, together with the specification
 387 of labels, description, ID number and unit of measurement for each variable.

388 *Table 2. List of variables considered in the analysis.*

Variable	Description	ID n°	Unit
SF_WAT	Supply fan power	1	W
RF_WAT	Return fan power	2	W
SA_CFM	Supply air flow rate	3	m ³ /h
RA_CFM	Return air flow rate	4	m ³ /h
OA_CFM	Outdoor air flow rate	5	m ³ /h
SA_TEMP	Supply air temperature	6	°C
MA_TEMP	Mixed air temperature	7	°C
RA_TEMP	Return air temperature	8	°C
HWC_DAT	Heating coil air temperature	9	°C
CHWC_DAT	Cooling coil air temperature	10	°C
SF_DP	Supply fan pressure drop	11	Pa
RF_DP	Return fan pressure drop	12	Pa
SF_SPD	Supply fan speed	13	%
RF_SPD	Return fan speed	14	%
OA_TEMP	Outdoor air temperature	15	°C
CHWC_EWT	Cooling coil input water temperature	16	°C
CHWC_LWT	Cooling coil output water temperature	17	°C
CHWC_GPM	Cooling coil water flow rate	18	m ³ /h
E_ccoil	Cooling coil power	19	kW
CHWC_VLV	Cooling coil valve position	20	%
EA_DMPR	Exhaust air damper position	21	%
OA_DMPR	Outdoor air damper position	22	%
RF_SST	Return fan start/stop signal	23	-

389

390 For the application of the proposed methodology, the data sample was split into two datasets. The
391 first one was used for the characterization of the normal operating condition of the system, while the
392 latter was used for the fault detection and diagnosis. The first dataset is composed of 20 days tagged
393 as “Normal” (training dataset), while the second by the rest of the days including 2 “Normal” days
394 and 11 “Faulty” days (testing dataset).

395 **4 Description of the data analysis methods**

396 In this section, the overview is presented of the techniques used for the proposed FDD methodology,
397 describing their main features in relation to the FDD problem under investigation.

398 **4.1 Adaptive symbolic aggregate approximation**

399 The Symbolic Aggregate approXimation (SAX) is a temporal abstraction technique capable to reduce
400 the dimension of a time series of length n in a time series of length m with $m < n$, and to transform it
401 in a symbolic string. The reduction of the time series is performed through a Piecewise Aggregate
402 Approximation (PAA), which segments the time axis in equally sized non-overlapping time windows
403 (i.e., aggregation intervals). The PAA approximates the original time series replacing the values
404 within the same aggregation interval with their mean value.

405 The transformation of the time series is then performed by substituting the values of the PAA with
406 symbols. To this purpose, the y-axis is discretized in a pre-defined number of regions and a symbol
407 is associated to each of them. Lin et al. in [46] proposed a simple procedure to perform the SAX,
408 employing a Z-score transformation (i.e., $Z(t) = \frac{x(t) - \mu}{\sigma}$ where μ is the mean value of the sample
409 and σ the standard deviation) before the data reduction and identifying the desired range of each
410 symbol assuming a-priori a Gaussian distribution of data.

411 A variation of SAX technique, called adaptive Symbolic Aggregate approXimation (aSAX), was
412 proposed in the literature [45] in order to improve the quality of the discretization in the case of non-
413 normal distribution of data. The adaptive symbolic aggregate approximation introduced by Pham et

414 al. [45] is based on the original SAX method, but an adaptive process is used for the identification of
415 breakpoints (i.e. the position of boundaries of each symbol range). The position of the adaptive
416 breakpoints is evaluated through a univariate clustering procedure, that minimises the total
417 representation error after the SAX transformation.

418 In this paper, the aSAX algorithm has been employed to improve the results of the automated and
419 unsupervised discretization process, which represents the most important analysis for ensuring the
420 robustness of the “event” extraction from time series.

421 4.2 Temporal Association Rules Mining

422 Association Rule Mining (ARM) is an unsupervised data mining method for identifying all
423 associations and correlations between attribute values in a set of categorical/discretized data [47]. The
424 output is a set of association rules that are used to represent patterns of attributes that are frequently
425 associated together (i.e., frequent patterns).

426 Let $I = \{i_1, i_2, \dots, i_d\}$ be the set of all items in a dataset and $D = \{d_1, d_2, \dots, d_d\}$ be the set of all
427 transactions. Each transaction d_i contains a subset of items chosen from I . In association analysis, a
428 collection of items is named *itemset* and the transaction width is defined as the number of items
429 present in a transaction. A transaction d_j contains an itemset X if X is a subset of d_j . An important
430 property of an itemset is its support count, that corresponds to the number of transactions that contain
431 a specific itemset. The support count, $\sigma(X)$, for an itemset X can be expressed as follows [47] (eq.1)

$$432 \quad \sigma(X) = |\{d_i | X \subseteq d_i, d_i \in D\}| \quad (1)$$

433 Association rules are usually represented in the form $X \rightarrow Y$, where X (also called antecedent) and
434 Y (also called consequent) are disjoint item sets (i.e., $X \cap Y = \emptyset$). Rule quality is usually measured
435 through rule support and confidence. Rule support is the fraction of the total number of transactions
436 in which both the item sets X and Y occur while confidence determines how frequently items in Y

437 appear in transactions that contain X. According to [47], Support $s(X \rightarrow Y)$ and Confidence $c(X \rightarrow Y)$
438 can be calculated with the following equations (eq. 2 and 3):

439
$$\text{Support, } s(X \rightarrow Y) = \frac{\sigma(X \cup Y)}{N} \quad (2)$$

440
$$\text{Confidence, } c(X \rightarrow Y) = \frac{\sigma(X \cup Y)}{\sigma(X)} \quad (3)$$

441 where N is the total number of transactions. Therefore, given a dataset D, the generic record of which
442 is a set of items, an ARM process discovers all association rules with support and confidence greater
443 than, or equal to, minimum thresholds defined a-priori by the analyst (i.e, MinSup and MinConf).

444 In the context of discrete-value-transactions, association rules can be used as an efficient method for
445 mining co-occurrences or implications also between events in the time domain (Temporal Association
446 Rule Mining (TARM)). TARM is an extension of sequential pattern mining, which is an important
447 data mining method with broad applications, capable to extract frequent itemset sequences while
448 maintaining their order. Many sequential pattern mining algorithms, such as GSP [48], PrefixSpan
449 [49,50], SPADE [51], and SPAM [52], have been proposed. However, those sequential pattern mining
450 algorithms consider only the itemset occurrence order, but do not consider the time intervals between
451 successive item sets (temporal constraint of event association). To that purpose, in the literature
452 several sequential pattern mining algorithms were proposed, to deal with the extraction of sequential
453 patterns considering the existence of interval between item sets (in terms of item gap and time
454 interval) [53–56]. Such algorithms extract rules, satisfying not only user-specified minimum support
455 constraints, but also user-specified gap constraints. The minimum and maximum gap values should
456 be defined as constraints by the user. For those rules, the search space in the time domain is
457 represented by a sliding window, the length of which is set in advance by the analyst. In detail, this
458 kind of rules can be represented in the following form: $X \xrightarrow{t} Y$. Therefore, the occurrence of the
459 antecedent itemset X implies the occurrence of the consequent itemset Y within a time t .

460 In this paper, the extraction of temporal association rules is performed by means of the cSpade,
461 algorithm based on [51]. The algorithm was implemented in R [69], including the rule extraction
462 phase which was performed by using the “cSpade” function of the “arules” package [70].

463 That algorithm extracts sequential rules, considering some constraints defined by the user according
464 to his/her needs. The constraints may drive the mining of frequent patterns from the database of
465 transactions, for instance by setting the length of the sliding window, or a minimum time gap between
466 antecedent and consequent of the rules.

467 However, since the database of transactions considered in the present study is generated by using a
468 sample-by-sample sliding window approach, the number of the transactions N results to be very high
469 with items mostly overlapped. For this reason, the calculation of rule support $s(X \rightarrow Y)$ cannot be
470 performed with the canonical formulation. In fact, the value of support $s(X \rightarrow Y)$ calculated according
471 to eq. 2 can be affected by the high value of the denominator (i.e., the total number of transactions),
472 suggesting the use of a formulation less sensitive to the sample size [57].

473 In this study, according to [58], the support of an association rule is defined as the ratio between the
474 number of transactions that include both antecedent and consequent, and the number of transactions
475 that include at least the consequent itemset (eq. 4).

$$476 \quad \text{Support, } s(X \rightarrow Y) = \frac{\sigma(X \cup Y)}{\sigma(Y)} \quad (4)$$

477 The support calculated with eq. 4 has the denominator dramatically lowered in comparison to the one
478 in eq. 2 and makes it possible to have high values of support also for large transaction datasets,
479 obtained through a sliding window. The support calculated through Eq. (4) assesses the frequency of
480 $X \cup Y$ on a smaller portion of the total number of transactions (i.e., only the transactions that include
481 the consequent itemset Y). The support is in the range (0-1) and allows an easier extraction of rules
482 to be assumed as reference patterns (i.e., with high support) of the occurrence of a specific condition
483 over time (i.e., consequent itemset Y). However, the confidence can be still calculated according to

484 Eq. (3) only if the consequent itemset Y occurs in a transaction not violating the chronological order
485 respect to the antecedent itemset X .

486 In general, the mining of association rules can be summed up as a two-step's procedure. In a first
487 phase, the frequent itemset with a support greater than the $MinSup$ are extracted, then the confidence
488 is considered for filtering out rules that consist in weak implications [59]. In this paper, the same two-
489 steps procedure is followed but additional metrics are also considered in the rule filtering phase (as
490 discussed in section 5.3).

491 4.3 Classification And Regression Tree

492 Decision trees are machine-learning algorithms that are used to develop descriptive and/or predictive
493 models from a collection of records. Each record can be expressed as a tuple (\mathbf{x}, y) , where \mathbf{x} represents
494 the explanatory attribute set while y is the target attribute. The type of target attribute is the key factor
495 that distinguishes classification from regression trees (i.e. discrete attribute in the first case and
496 continuous attribute in the second one) [47]. In this work, the Classification And Regression Tree
497 (CART) algorithm, based on recursive partitioning algorithm [60], has been selected to conduct a
498 predictive modelling task, as it is able to easily handle categorical attributes as both explanatory and
499 target attributes. The CART is a specific machine learning technique that is based on a recursive
500 binary splitting of the whole feature space into finite disjoint sets, and its output can be translated into
501 a hierarchical tree structure composed by nodes and directed edges (i.e., branches). The leaves (i.e.,
502 final nodes) represent the predicted class labels of the target attribute, while the branches represent
503 the conjunctions of the explanatory attributes that lead to the class labels

504 The development of a classification tree unfolds over two steps: training and testing of the model.

505 Each decision tree developed has been pruned following a cost-complexity approach and validated
506 through a k -fold cross validation process as explained in [61]. The development of a classification
507 tree unfolds over two steps: *training* and *testing* of the model. Firstly, all the records are grouped in

508 the root node and the CT algorithm iteratively evaluates the best partitioning of the dataset, using the
509 explanatory attribute that minimises the average impurity measure (e.g., Gini index, Entropy) of the
510 child nodes after each split. If no stopping rules are set by the analyst, the classification tree grows
511 continuously until the impurity in the leaf nodes of the target variable is zero. In order to avoid this
512 condition of model overfitting, various types of appropriate early stopping criteria can be set in
513 advance by the analyst (e.g., minimum number of cases in parent and child nodes, maximum tree
514 depth, minimum reduction in node impurity after splitting). Even when the early stop criteria have
515 been satisfied, the tree may continue to be quite large and/or complex completely losing its
516 interpretability. For this purpose, it is possible to define a cost-complexity parameter (cp) during the
517 model validation phase, for optimising the trade-off between the cost of misclassification and the tree
518 complexity. Therefore, the cp allows the analyst to set the right tree size by pruning branches and leaf
519 nodes that do not significantly increase the model performance.

520 Starting from the fully grown tree, the cost-complexity pruning procedure is repeated iteratively, and
521 smaller and smaller subtrees are found until the root node is reached. At the end of the iterations, the
522 final pruned tree can be evaluated by plotting the relative errors of the subtrees versus their cp values.
523 This kind of plot usually shows an initial sharp drop, followed by a relatively flat region. When the
524 decision tree is subject to a validation procedure (e.g., k-fold cross-validation), it is also possible to
525 compute a standard error for each relative error of the sub-tree. The choice of the best subtree starts
526 from the flat region of the subtree errors that includes the minimum cross validated error that has
527 been achieved. In fact, the values falling within one standard error of the achieved minimum risk (i.e.,
528 1-SE rule) identify statistically equivalent sub-trees [60]. The simplest model (with the minimum
529 number of final nodes) of all the identified sub-trees in the flat region is then chosen.

530 K-fold cross-validation has been used in this paper. For this kind of method, the original sample
531 of data with M objects is divided into k equal sized subsamples. A single subsample is selected for
532 the evaluated k subsamples as a validation dataset for testing the model, and the remaining $(k-1)$

533 subsamples are used for the training. This process is then repeated k times, using a subsample at a
534 time for the testing

535 In this paper, all the classification trees developed for extracting decision rules have been subjected
536 to the previously described procedure of validation and pruning (as discussed in section 5.4).

537 **5 Methodological framework of analysis**

538 The methodology relies on the application of both supervised and unsupervised algorithms to perform
539 robust fault detection and diagnosis in AHUs.

540 The framework unfolds over different stages as shown in Figure 3. Two different analytics modules
541 are proposed for developing an FDD tool tailored for both transient and non-transient conditions of
542 the AHUs operation. For that purpose, in the methodological framework, a data segmentation phase
543 is preliminarily carried out in order to split the data according to the regime of operation they belong
544 to (i.e. transient or non-transient). In the following sections the pre-processing analysis, applied to the
545 entire dataset, and the two analytics modules, tailored for transient and non-transient periods,
546 respectively, are then described.

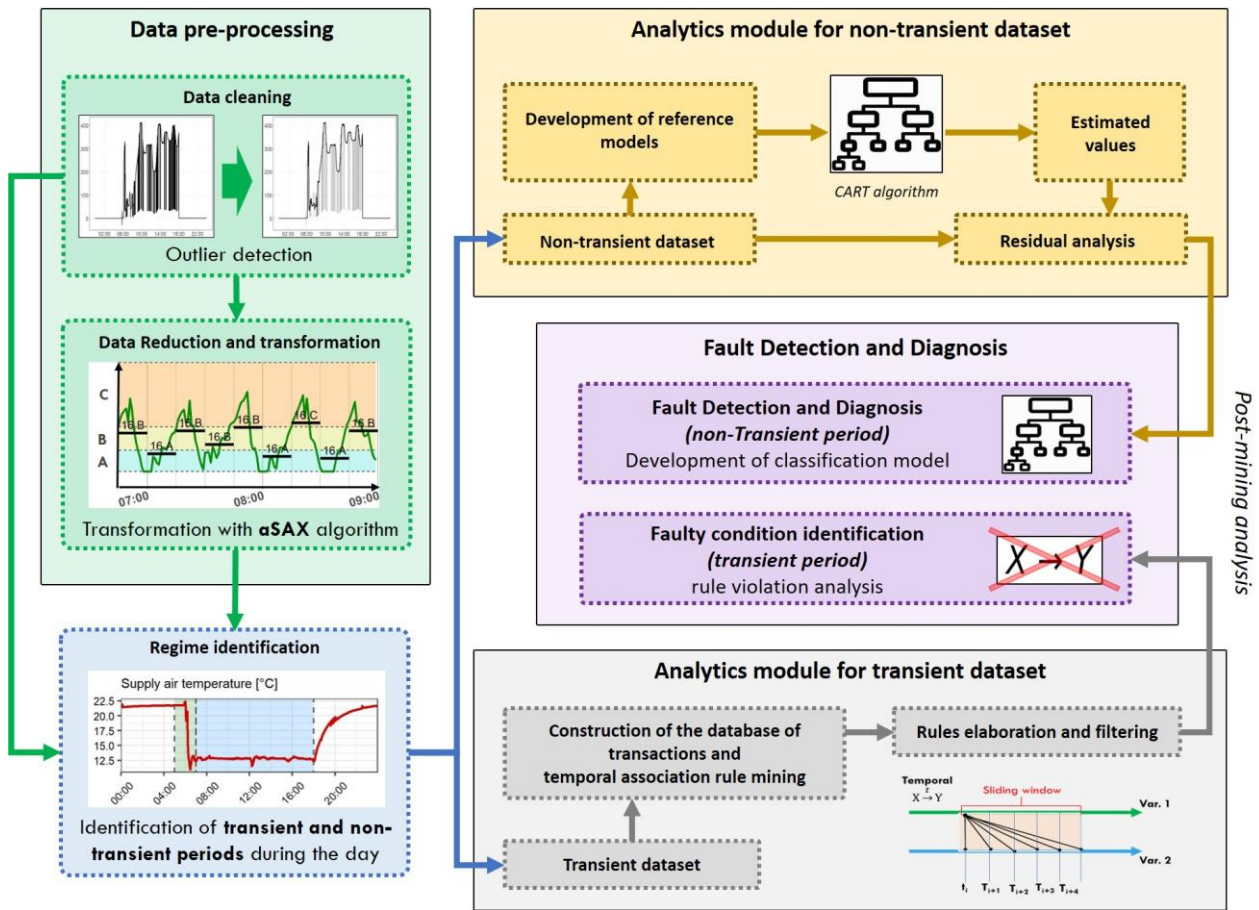

Figure 3. General framework of the analysis.

547

548

549 5.1 Data pre-processing stage

550 The pre-processing stage consists of three main tasks i.e., cleaning, reduction and transformation,
 551 typically accomplished for preparing the data sets. In detail, outlier detection and replacement are
 552 firstly performed (for each time series) by using the Hampel filter method [62]. For each data point
 553 in the time series, the algorithm computes the median of a window that includes the considered data
 554 point and its k surrounding samples. If a data point differs from the median by more than a standard
 555 deviation, it is tagged as a statistical outlier and replaced with the median.

556 The monitoring data were available in time-series with a sampling time of 1-minute, which would
 557 make the analysis onerous to be performed. For this reason, in a successive step a data reduction and
 558 transformation process is performed by means of the adaptive Symbolic Aggregate Approximation
 559 (aSAX) method [45]. This algorithm is employed for reducing the time series through a piecewise

560 technique aggregating data with a fixed length window from 1 minute to 15 minutes and then for
 561 transforming it into a symbolic string. The objective is to maximise data compression and minimise
 562 the complexity of the time series while preserving important information. The symbolic
 563 representation of time series is always subjected to information loss due to the piecewise aggregate
 564 approximation (especially information about the slope). However, when the segments are encoded in
 565 symbols it is possible to preserve qualitative information about global trends of the time series, and
 566 to easily detect important changes of patterns over time.

567 Figure 4 reports an example of data reduction and transformation through aSAX algorithm for a
 568 portion of the time series related to the variable encoded with the ID n° 16 according to Table 2 (i.e.,
 569 *cooling coil input water temperature* (CHWC_EWT)). The figure shows the time series after the
 570 application of the Hampel filter (green curve) and the time series in form of constant approximated
 571 piecewise (black lines). Furthermore, Figure 4 also shows the result of the aSAX transformation of
 572 the time series into a symbolic string. The variable can assume three discrete values encoded with the
 573 symbols 16.A, 16.B or 16.C according to the region the piecewise segments of 15-min fall in.

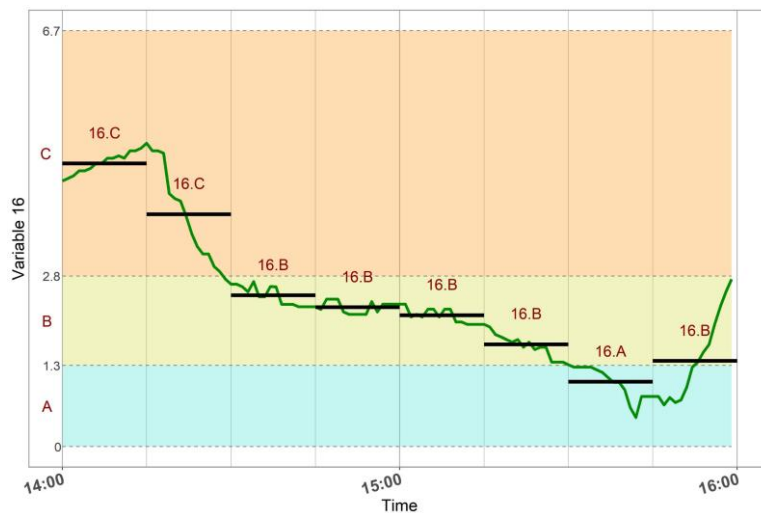

574
 575 *Figure 4. Example of aSAX transformation for a numerical variable.*

576 The obtained symbol sequence is 16.C-16.C-16.B-16.B-16.B-16.B-16.A-16.B from which it is
 577 possible to infer that the original time series is characterized by changes in the pattern at times 14:30,
 578 15:30, 15:45, that in this work are intended as events.

579 As a result, time series are transformed in discrete-time discrete-value sequences of equidistant
580 symbols making it possible to extract events from them.

581 5.2 Regime identification

582 At this stage, a regime identification is performed on a daily scale, to detect when transient and non-
583 transient conditions typically occur during the AHU operation.

584 To that purpose, an automatic regime detector is used to identify the transient period and separate it
585 from the non-transient one. The details of the detector used are the same as that reported in [16][63].

586 The transient identification is performed on data with sampling time of 1 minute, specifically
587 analysing the *cooling coil valve position* (CHWC_VLV), the *supply air temperature* (SA_TEMP),

588 *supply fan speed* (SF_SPD) and the supply air static pressure. Then, the frequency of transient data
589 points during the day is evaluated for each 15-min aggregation interval, derived from the data

590 reduction phase (Figure 5). Thanks to that analysis, it is possible to establish during which
591 aggregation interval, out of the reduced (15-min-long) daily time series, a transient condition has the

592 highest frequency of occurrence.

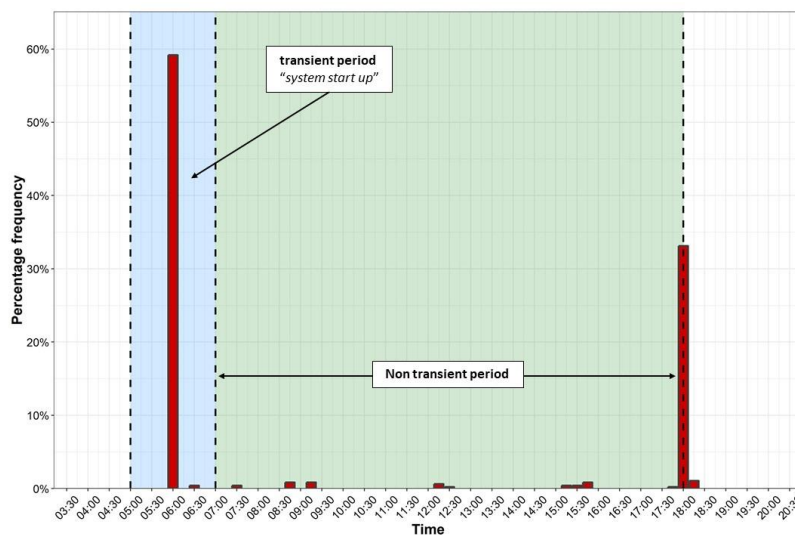

593

594

Figure 5. Identification of the transient period.

595 Starting from such aggregation interval of 15 min, the transient period is evaluated considering a time
596 window of two hours (i.e., blue area of the plot) that includes one hour before and later the aggregation
597 interval considered (Figure 5).

598 As can be noticed from Figure 5, transients occur at the start-up and the shut-down of the AHU.
599 Among the two transient periods, only the start-up transient is investigated in this paper because
600 during that period the system dynamics affects the successive operation, while in the other case the
601 system is thereafter turned off.

602 As a result, the non-transient period is supposed to start at the end of the start-up time interval and to
603 end when the system is turned off.

604 Therefore, excluding the night hours, during which the AHU is certainly not operated, the dataset is
605 segmented as follows:

- 606 • From 05:00 to 07:00: transient period labelled as “*system start-up*”;
- 607 • From 07:00 to 18:00: non-transient period.

608 In the following sections a tailored FDD methodology for each operation regime of the systems under
609 analysis (i.e., transient, non-transient) is presented.

610 5.3 FDD methodology for the transient period

611 The main flow of FDD research reported in literature has been carried out in a steady-state approach
612 [14,17,19,64,65], because the operating characteristics during this operation is relatively more
613 credible and reproducible than in a transient state [64].

614 Transient data are characterised by great variation in the time domain and require specific data
615 analytics algorithms to be employed to properly reflect the system dynamics. The herein proposed
616 methodology provides, as a main added value to what was already present in literature papers, a
617 tailored approach for such condition of operation.

618 An overall procedure is developed to obtain temporal association rules that are representative of
619 frequent relationships between events in multiple time series, using a time window and a time lag.
620 As discussed in Section 4.2 temporal association rules are an interesting extension of association rules
621 that include a temporal constraint, which leads to different forms of IF-THEN implication over time.
622 When an event leads to the occurrence of another event, there may be causal relationship or certain
623 correlation between them. The corresponding mining purpose is to find out the reference fault-free
624 association rules between events and time in a temporal transaction dataset, whose violation can
625 suggest the presence of faulty conditions during the start-up period of the AHU system. The extraction
626 makes it possible to find those sequences of events that appear many times among monitored fault-
627 free days and have a high rate of occurrence (i.e., reference rules).
628 The reference association rules have been searched in the 20 days tagged as fault-free (training
629 dataset) while the remaining 2 fault-free days and 11 faulty days (testing dataset) were used in the
630 successive fault detection phase.

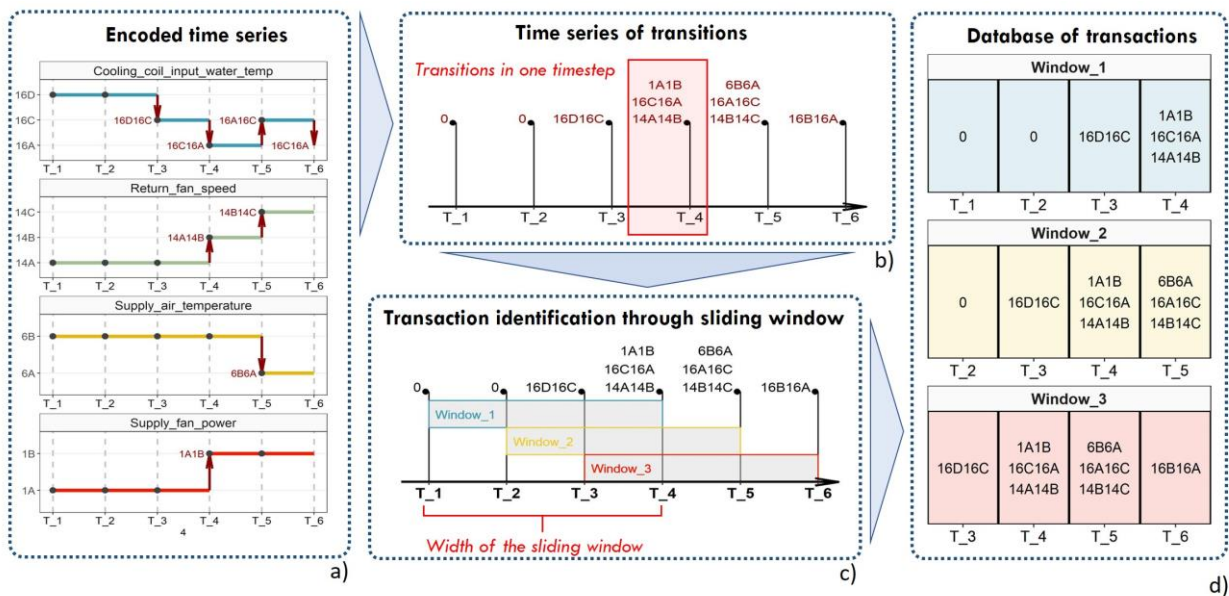

631
632 *Figure 6. Procedure for the construction of the database of transactions.*
633 Before extracting reference temporal association rules from data, it is necessary to create the database
634 of transactions T following the framework shown in Figure 6.

635 The first step consists of putting together all the transitions that occur in each time series into a unique
636 multivariate time series of transitions.

637 In particular, according to the symbolic transformation performed during the pre-processing stage a
638 transition in a time series is a kind of event that corresponds to the change of symbol (i.e., encoded
639 discrete values of the variable) in a specific timestep across two consecutive aggregation intervals.

640 As an example, Figure 6 (a) shows six timesteps of four time series (i.e., *cooling coil input water*
641 *temperature* (CHWC_EWT), *return fan speed* (RF_SPD), *supply air temperature* (SA_TEMP), *supply*
642 *fan power* (SF_WAT)). The time series *supply fan power* (SF_WAT) corresponds to the operation
643 variable of the AHU encoded with the ID n° 1 and assumes only two discrete values (encoded with
644 the symbols 1A and 1B) along the six timesteps considered. In the same way the time series *return*
645 *fan speed* that corresponds to the operation variable of the AHU encoded with the ID n° 14, assumes
646 three discrete values (encoded with the symbols 14A, 14B and 14C) among the six timesteps. If two
647 consecutive aggregation intervals are encoded with the same symbol, no transition (i.e., event) is
648 detected. Otherwise, during a specific timestep, a transition (i.e., event) is encoded reporting the ID
649 n° of the variable and the two symbols included in the change of discrete value. For example,
650 according to Figure 6 (a), at the first timestep T_1 for any time series, a transition does not occur and
651 then 0 is stored in the time series of transitions (Figure 5 (b)). On the contrary, at the fourth timestep
652 T_4, a transition occurs for the time series 1, 14 and 16. In particular, for time series 1 and 14, occurs
653 a change from symbol “A” to symbol “B” (events encoded as “1A1B” and “14A14B” respectively)
654 while for time series 16 the variable changes symbol from “C” to “A” (event encoded as “16C16A”).

655 Once the encoded events are stored in the multivariate time series of transitions (Figure 6b), the
656 database of transactions is constructed by chunking this time series considering a fixed-length sliding
657 time window (Figure 6 (c)). Figure 6 (d) shows how the encoded transitions for each timestep are
658 stored in the database of transactions. For example, assuming a sliding window that includes four
659 timesteps, the database T can be represented by a $4 \times n$ transition matrix where n corresponds to the
660 maximum number of sliding windows which can be contained in the time series of transitions.

661 Considering that the time windows are sliding a timestep by time, two consecutive rows in the
662 database T (Figure 6 (d)) differ only for a single item. As a reference considering a time series of
663 transitions with 6 timesteps and a sliding window that includes 4 timesteps, the database of
664 transactions is a 4×3 transition matrix given that the maximum number of complete time windows
665 is equal to 3 (Figure 6 (d)). After the construction of the database T, the temporal association rules
666 are searched among transactions.

667 The cSpade algorithm [51] has been selected for the extraction of the rules from the inter-transactional
668 database, setting in advance three fundamental parameters: minimum confidence, minimum support,
669 and maximum time lag between antecedent and consequent item sets (equal to the sliding window
670 length).

671 According to the proposed methodology, the first two parameters (i.e., confidence and support)
672 should be as high as possible, to ensure that the extracted rules are much frequent as possible and
673 then representative of the normal behaviour of the system.

674 Once the reference rule set has been identified, it is used for detecting the presence of potential faults
675 in a testing dataset.

676 In particular, a temporal association rule is expressed as a logical IF-THEN implication where the
677 presence of an event (i.e., antecedent) implies the occurrence of another event (i.e., consequent)
678 within a certain time lag. According to this formulation, three potential violations can occur when
679 such rules are applied on a testing set of data:

- 680 i) absence of the antecedent itemset,
- 681 ii) absence of consequent itemset,
- 682 iii) absence of antecedent and consequent item sets.

683 In that perspective, the violation analysis helps physical interpretation of rules making it possible to
684 assess their sensitivity to the presence of specific faults or group of them.

685 In section 6.2, the results of the transient methodology herein described are presented and discussed
686 providing further details about the setting of the input parameters and the post-processing of the
687 extracted association rules.

688 5.4 FDD methodology for the non-transient period

689 The methodology employed for performing the FDD analysis during non-transient period relies on
690 three fundamental phases that can be generalized as follows:

- 691 • Development of reference models through classification trees, representative of the normal
692 behaviour (fault-free condition) of the system under analysis;
- 693 • Comparison between the estimated behaviour of the system and the actual one (i.e., evaluation
694 of model residuals) for detecting potential faulty conditions;
- 695 • Analysis of the model residuals for diagnosing the most probable cause associated to a specific
696 fault (fault diagnosis).

697 The first step of the process consists of a robust characterization of the fault free operation of the
698 AHU during the non-transient period (i.e., from 07:00 to 18:00). To this purpose, several estimation
699 models (i.e., classification trees) have been developed on a portion of the available non-transient
700 dataset. In detail 20 days tagged as fault-free were considered at this stage (training dataset) while the
701 remaining 2 fault-free days and 11 faulty days (testing dataset) were used in the successive diagnostic
702 phase.

703 For the development of the estimation models (i.e., classification trees), all the variables related to
704 the operation of the AHU (e.g., *supply fan power* (SF_WAT), *return fan power* (RF_WAT), *supply*
705 *air flow rate* (SA_CFM)) have been selected once at a time as target attribute while the remaining
706 ones have been used as input attributes. However, features related to external forcing variables to the
707 AHU system (i.e., *cooling coil input water temperature* (CHWC_EWT), *outdoor air temperature*
708 (OA_TEMP)) have been used only as input attributes.

709 In that way, 21 classification trees are developed for providing a robust benchmark of the fault-free
710 operation. To that purpose, a CART algorithm is employed as a supervised classifier in the study.
711 The developed classification trees estimate for each target variable and for each 15-min aggregation
712 interval included in the non-transient period the most probable discrete value (encoded as symbol)
713 according to the relationship that exists between all the input variables and the dependent attribute.
714 Successively all the classification trees developed are put together in the same estimation layer as
715 shown in Figure 7. At this stage, the estimation process can be summarized as follows:

- 716 • At each aggregation interval (i.e., 15 min.) the monitored variables are encoded into symbols
717 through the aSAX method (i.e., pre-processing stage);
- 718 • The set of encoded variables goes through the estimation layer (that consists of 21
719 classification trees) providing an estimation of each target variable for the considered
720 aggregation interval;
- 721 • The actual symbols are compared with the estimated ones.

722 The latter step consists in the evaluation of the model residuals.

723 In this study, the difference between two equal symbols is assumed to be zero, while the residual
724 differs from zero if the symbols are at least one alphabet apart. For example, if the estimated and
725 actual symbol for a variable is equal to “A” and “B” respectively, the residual between those symbolic
726 discrete-values is equal to 1 (Figure 7).

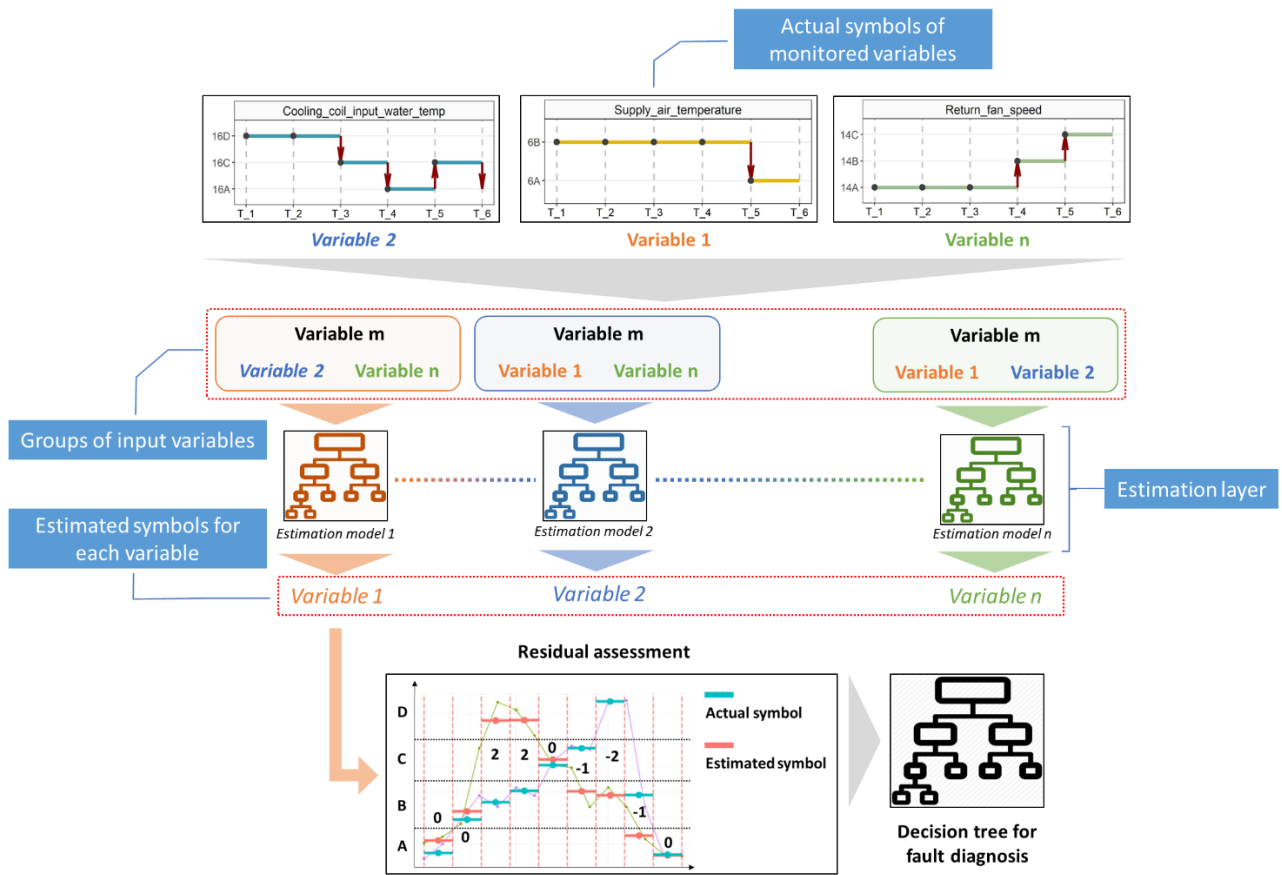

Figure 7. Analytics module for the non-transient period.

727

728

729 Considering that the estimation models are trained on fault-free data, at the end of the estimation
 730 process it is possible to assess how much the input data differ from the reference fault-free behaviour
 731 of the AHU through the analysis of residuals. Understanding which variables are out of range and
 732 assessing the severity of those deviations enables the detection of possible faulty conditions. In order
 733 to test this FDD procedure, all the days excluded from the training set of the reference models (i.e., 2
 734 fault-free days and 11 faulty days) have been considered. In particular, each day included in the testing
 735 dataset is labelled as “Normal” or with the tag of one of the faults reported in Table 1.

736 The time series of the 13 days are pre-processed (aggregated in intervals of 15-min and encoded in
 737 symbols) and put through the estimation layer (i.e., 21 classification trees) generating a dataset of
 738 residuals as shown in Figure 8. At this stage, a further classification tree has been developed to predict
 739 the label of each faulty or normal condition (Figure 8) for performing the fault diagnosis. This
 740 classification tree estimates the most probable label (e.g., CCVSFC, EASFC, RFCF or Normal)
 741 according to the residuals evaluated for each variable as an outcome of the estimation layer.

Aggregation interval	Day	Variable 1 Residual	Variable n Residual	Variable 21 Residual	Fault label
15:00 – 15:15	1	0	...	0	Normal
15:15 – 15:30	1	0	...	0	Normal
15:30 – 15:45	1	0	...	0	Normal
...
15:00 – 15:15	5	1	...	3	CCVSFC
15:15 – 15:30	5	0	...	-1	CCVSFC
15:30 – 15:45	5	-2	...	0	CCVSFC
...
15:00 – 15:15	10	2	...	1	EASFC
15:15 – 15:30	10	1	...	0	EASFC
15:30 – 15:45	10	0	...	-2	EASFC
...
15:00 – 15:15	13	-3	...	1	RFCF
15:15 – 15:30	13	1	...	-2	RFCF

Set of input variables of the classification tree
Target variable of the classification tree

742

743

Figure 8. Structure of the database used for developing the classification tree of fault diagnosis

744

In the dataset reported in Figure 8 the target variable is the fault tag, and the same tag is assigned to all of the 44 aggregation intervals of 15-min that belong to the same day (included in the 11 hours of “non transient” operation of the AHU from 7:00 to 18:00), generating a total amount of 572 instances on which develop the classifier. The present methodology exploits the CART algorithm for developing the decision trees since it proved to be a good choice for fault diagnosis [19][66].

749

As already mentioned above, in this paper the developed FDD tool is trained and tested on real data of an AHU operated in non-transient cooling mode for 33 non-consecutive days during the summer season (22 “normal” days and 11 “faulty” days). Note that the decision and association rules extracted through the proposed supervised and unsupervised approaches can be considered valid only for the operation mode under consideration. In this perspective, rule-based tools can be easily integrated in FDD process with hierarchical architecture capable to exploit only the useful knowledge during specific conditions. For instance, the use of automatic detector makes it possible to call specific sets of rules depending on the operating mode of the AHU: off mode, heating mode, free cooling mode, and mechanical cooling mode [67].

758

In Section 6.3, the results of the non-transient methodology herein described are presented and discussed providing further details about the performance, reliability and generalizability of the entire process.

760

761 6 Results

762 6.1 Pre-processing stage

763 According to the methodological framework introduced in Section 5, a data preparation stage was
764 preliminarily implemented. Firstly, outliers were filtered out by implementing the Hampel filter on
765 the 1-minute time series. For each data sample of the time series, the filter computes the standard
766 deviation and the median of a window composed of the current sample and $\frac{Len-1}{2}$ adjacent samples
767 on each side of the current sample. *Len* is the window length and in this study is set equal to 31
768 minutes. A window with a length of 31 minutes could be not too much sensitive to the presence of
769 outliers considering that the sample on which the standard deviation is computed is quite large.
770 However, such window length proved to be suitable for identifying extremal values that certainly are
771 related to problems of the sensing system. In the performed analysis, the filter does not take into
772 account the first and the last $(Len-1)/2$ data points of each daily time series. Such data points are
773 always related to measurements during the hours when the AHU system is turned off (time intervals
774 from 00:00 to 00:14 and from 23:45 to 23:59) and do not affect the results in any ways.

775 After data pre-processing (i.e., cleaning and replacement of outliers) a data reduction was performed
776 by means of a PAA process with the aim of approximating the time series of each considered variable
777 to the mean value calculated in non-overlapped time intervals with a fixed length of 15 min. The time
778 interval length of 15 minutes was chosen as the best trade-off between approximation accuracy and
779 data size reduction. Successively, the encoding of the reduced variables in symbols was carried out
780 by implementing the aSAX algorithm [45].

781 The algorithm was initialised for each variable by identifying the number of symbols (i.e.,
782 discretization intervals) and the initial positions of the breakpoints (i.e., borders of the discretization
783 intervals) with a hierarchical cluster analysis using the Ward linkage method [47]. Through the
784 clustering algorithm, it was possible to obtain the optimal number of discretization intervals (i.e.,

785 number of symbols) by computing several cluster validation metrics. This process was completely
 786 automated and performed through Nbclust package [68] available in the statistical software R. The
 787 number of discretization intervals was constrained from 2 to 4 considering only data referred to the
 788 period of operation of the system (i.e., ON-hours of the system).

789 When the optimal positions of the adaptive breakpoints were found and each variable was encoded
 790 in symbols, the operation conditions of the AHU were considered fully characterised. Then, the data
 791 related to OFF-hours of the system operation were analysed to find possible additional intervals. In
 792 particular, if during OFF-hours a variable typically assumes values that are out of the identified ranges
 793 of discretization, a new lower or upper half-open interval was appended to the previous ones.

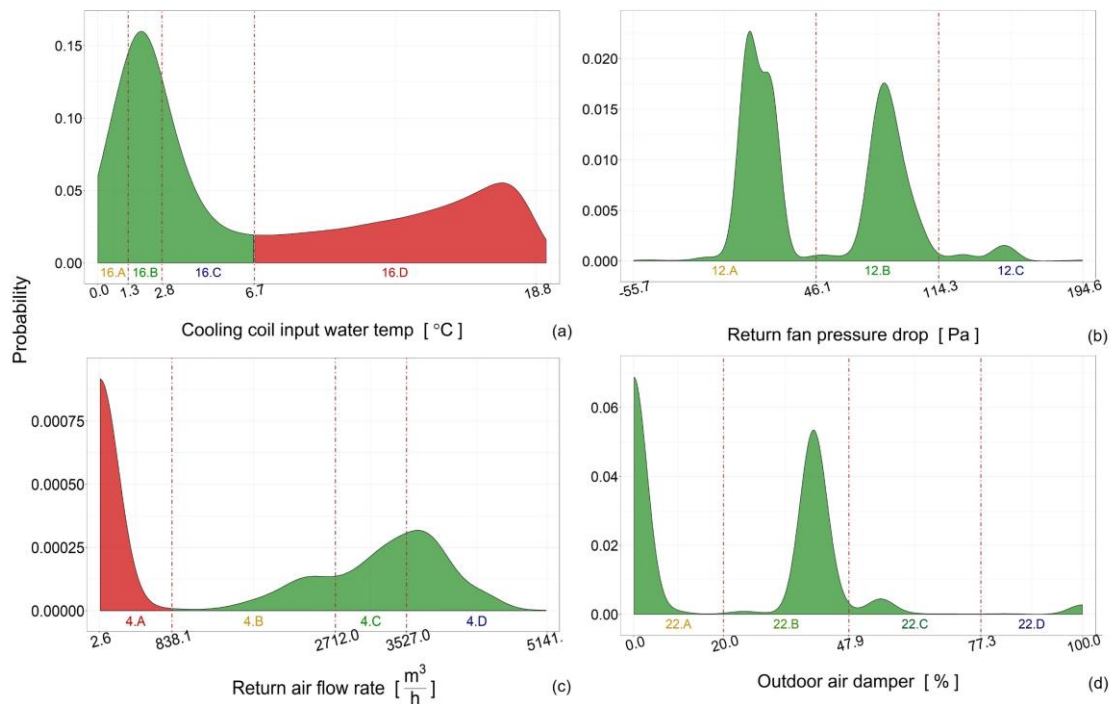

794
 795 *Figure 9. Distributions and breakpoint identification for some variables.*

796 Figure 9 shows the encoding process performed for 4 variables (i.e., *cooling coil input water*
 797 *temperature* (CHWC_EWT), *return fan pressure drop* (RF_DP), *return air flow rate* (RA_CFM),
 798 *outdoor air damper position* (OA_DMPP)) randomly selected from the set of inputs. It can be
 799 observed that for two variables an additional OFF-hours discretization interval (i.e., red area of the
 800 distributions in Figure 9 (a) and (c)) was added to the other ranges of values for the symbol encoding
 801 (i.e., ID n° = 16, symbol = D and ID n° = 4, symbol = A).

802 As a reference, Table A in Appendix A summarizes the transformation results obtained, with the
803 specification of the numerical range corresponding to each symbol for all the analysed operational
804 variables.

805 At this stage, according to the procedure described in Section 5.2, transient and non-transient periods
806 were identified and the data set was consequently segmented. In particular, the time interval between
807 5:00 and 7:00 was labelled as transient start-up period, while the period from 7:00 to 18:00 was
808 considered as non-transient period. The results obtained from the application of the methodological
809 framework are in the following presented and discussed separately for transient and non-transient
810 periods.

811 6.2 Fault detection analysis for the transient period (system start-up)

812 According to the methodological process introduced in section 5, the encoded time series were
813 analysed for extracting temporal association rules in the start-up period of system operation. In detail,
814 the transitions of the variables (i.e., change from a symbolic discrete-value to another one) were
815 preliminarily encoded and the inter-transactional database was created considering a sliding window
816 of 60 minutes. The width of the sliding window was chosen to be large enough to include any effect
817 of the system dynamics, but tight enough to ensure that the occurrence of a consequent itemset was
818 related to a physics-based implication with its antecedent itemset.

819 Considering that the fault detection methodology was conceived for extracting reference association
820 rules of normal operation, the inter-transactional database was created from the fault-free dataset, by
821 selecting rules with high values of support and confidence.

822 Typically, the main issue related to association rules mining consists in handling and filtering the
823 large number of rules extracted and eventually identify those that are of interest [20]. To tackle this
824 problem and facilitate the mining of useful knowledge from extracted rules, a post-mining phase was
825 performed.

826 The post-mining phase was aimed at solving various practical issues, such as interestingness,
827 redundancy, generalization, visualization and interpretability of association rules.

828 To this purpose, additional quality metrics were introduced: the daily support of the rule (i.e.
829 SUPP.DAY) calculated for both fault-free (SUPP.DAY_{NORMAL}) and the faulty days
830 (SUPP.DAY_{FAULTY}) and the actual time lag between the antecedent and consequent of a rule
831 (ACTUAL TIME LAG). In more detail, the SUPP.DAY_{NORMAL} is defined as the percentage of fault-
832 free days during which a single association rule (R_i) occurred, while SUPP.DAY_{FAULTY} is calculated
833 for the faulty days (Eq. (5) and Eq. (6), respectively).

834

$$835 \quad SUPP.DAY_{NORMAL}, R_i = \frac{\text{N}^\circ \text{ of Free-fault days with of the occurrence of the rule } R_i}{\text{Tot. N}^\circ \text{ of Free-fault days}} \quad (5)$$

836

$$837 \quad SUPP.DAY_{FAULTY}, R_i = \frac{\text{N}^\circ \text{ of Faulty days with of the occurrence of the rule } R_i}{\text{Tot. N}^\circ \text{ of Faulty days}} \quad (6)$$

838 However, according to ASHRAE project RP-1312, during the faulty day tagged as CCVSFO (i.e.,
839 cooling coil valve stuck open), the blockage of the cooling valve in fully open position was
840 implemented from 8:00 to 18:00 and hence out of the start-up period of the system. For this reason,
841 the day tagged as CCVSFO has been not considered in the calculation of SUPP.DAY_{FAULTY}.

842 The ACTUAL TIME LAG was introduced to evaluate the most frequent temporal distance between
843 the first occurrence of an antecedent and the last occurrence of the corresponding consequent of a
844 specific rule. Consequently, even though the rules are searched with a sliding window of 60 minutes,
845 the user can have a feedback about the most frequent time interval within a consequent occurs given
846 the presence of its antecedent.

847 The ACTUAL TIME LAG was calculated for each rule by computing the cumulative frequency of
848 occurrences of the temporal distance between antecedent and consequent. For each rule a cumulated
849 frequency threshold of 80% was considered in order to evaluate this metric.

850 Figure 10 shows the frequency distribution of the ACTUAL TIME LAG for two rules. The rule on
851 the left (i.e., rule 1077) occurs for more than the 80% of the time with an actual time lag between the
852 antecedent itemset and consequent itemset of 15 minutes, while for the rule on the right (i.e., rule
853 15268) the 80% of occurrences has a characteristic time lag lower or equal to 30 minutes.
854

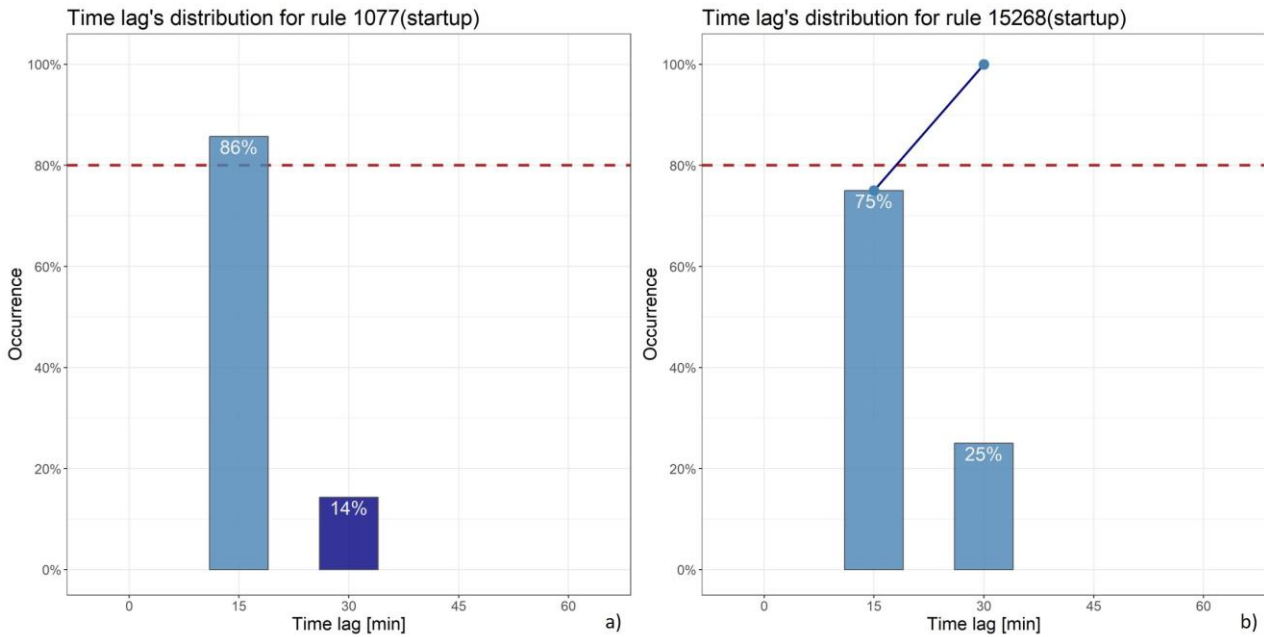

855
856 *Figure 10. Distribution of the time lags for rule 1077 (a) and rule 15268 (b) – (refer to Table B in Appendix A for the*
857 *description of the rules).*

858 At this stage, more than 15,000 rules were extracted from the start-up dataset of fault-free days (in
859 more or less 10 min.), assuming minimum support and minimum confidence equal to 0.7 and not
860 including drivers of system's operation as potential consequent events (i.e. *outdoor air temperature*
861 (*OA_TEMP*) and *cooling coil input water temperature* (*CHWC_EWT*)).

862 After the rule extraction, the values of support and confidence were recalculated considering only the
863 occurrences of each rule within the evaluated ACTUAL TIME LAG (instead of the window of 60-
864 min), reducing the set of rules to 7,419 rules.

865 Since the rules extracted should be representative of the fault-free operation of the system, only the
866 rules, which in the testing dataset frequently occur in normal days and rarely in the faulty ones, are
867 of interest for the problem under investigation. To this purpose, after the application of the 7,419

868 temporal association rules to the testing dataset, only the rules with a SUPP.DAY_{NORMAL} equal to 1
869 (i.e., the rule occurring for each day labelled as “normal” included in the testing dataset) and a
870 maximum value of SUPP.DAY_{FAULTY} equal to 0.3 were considered with the final result of obtaining
871 465 reference rules (SUPP.DAY values are set by the user).

872 As a general approach, the parameters were set in order to obtain a limited number of interesting
873 rules, which respect the following conditions i) each rule occurs during fault-free condition with high
874 support and confidence, ii) each rule has high probability to be violated during faulty conditions
875 regardless from the fault type.

876 In this perspective, general rules that are sensitive to more fault types at the same time were preferred
877 to those violated only for specific faults.

878 The introduced metrics allow an enhanced comprehension of the rule set, making it possible to
879 discriminate rules with high support and confidence occurring during both fault-free and faulty days,
880 from the rules, robust as well, occurring only during the normal operation of the system.

881 Figure 11 shows for each day in the testing dataset (composed by 11 different faulty days and 2
882 Normal days) the percentage of rules (out of the 465 considered) which occurred and/or have been
883 violated, with specification of the kind of violation detected. In particular, the label “*presence*”
884 indicates that the rule occurred with its antecedent and consequent while the labels “*antecedent*”,
885 “*consequent*” and “*absence*” indicate three different types of violation. In detail, the label
886 “*antecedent*” denotes that a rule was violated because of the only presence of the antecedent; the label
887 “*consequent*” indicates that a rule was violated because of the only presence of the consequent; the
888 label “*absence*” indicates the complete violation of a rule because of the absence of both antecedent
889 and consequent. The characterisation of the rules in terms of type of violation helps the interpretation
890 of the path which determines a specific fault. In fact, the presence of the only antecedent, the only
891 consequent, rather than the absence of both item sets, correspond to different behaviours of the system
892 in relation to the presence of the considered faults.

893 The results obtained can be described according to the severity of rule violation for each day
 894 representative of a specific fault implementation or normal operation. To this purpose four different
 895 groups of days were identified and in the following described.

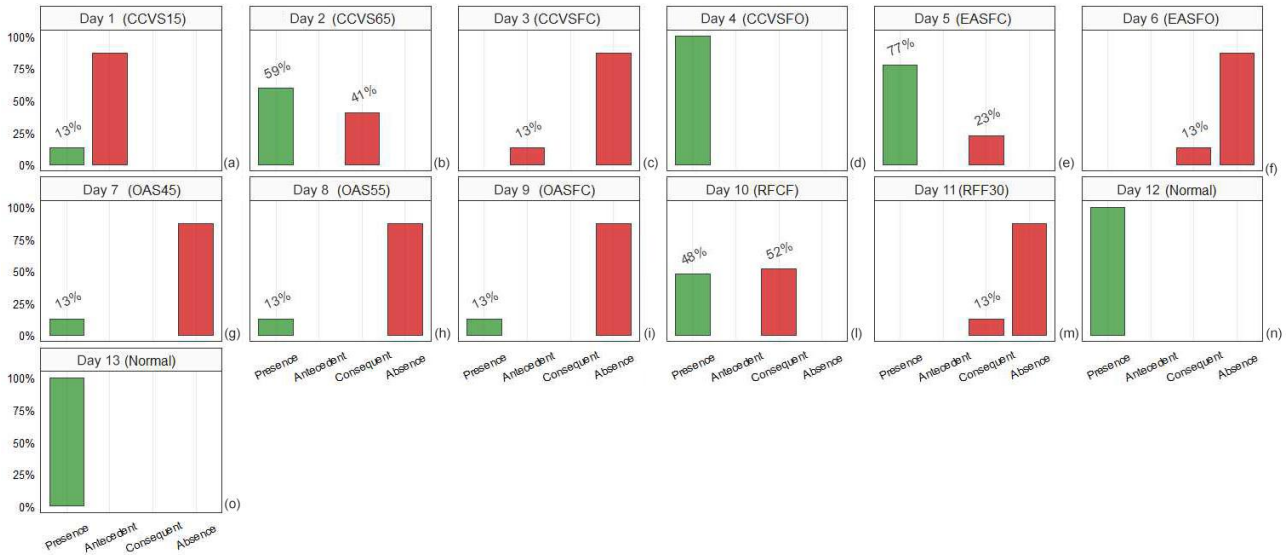

896
 897 *Figure 11. Characterization of the presence or the violation of the extracted rules for the testing days (refer to Table 1*
 898 *for the encoding of faults).*

899 The first group includes days characterized by the presence of the 100% of the 465 rules tested. This
 900 is the case of days in Figure 11 (d), (n) and (o) tagged as Normal and the faulty day tagged as
 901 CCVSFO. Such condition suggests, as expected, that during the faulty day CCVSFO the start-up of
 902 the system can be considered normal.

903 The second group instead, includes the days in Figure 11 (a), (c), (f), (g), (h), (i) and (m) that are
 904 characterized by a net prevalence of rule violations (more than 70%). Moreover, for those days, the
 905 presence of a fault is also associated to a specific kind of violation of the rules. As a reference, in case
 906 of CCVSFC, EASFO, OAS45, OAS55, OASFC and RFF30 the rules are violated mainly due to the
 907 absence of both antecedents and consequents, while only in the in case of CCVS15 the rule was
 908 violated for the absence of consequent.

909 The third group includes the day in Figure 11 (e) for which, during the start-up period, the percentage
 910 of violations is lower than the percentage of valid occurrences of the rules. Such condition suggests
 911 that during this day the behaviour of the system is similar to the normal one limiting the number of

912 violations occurred. The main reason is that such fault does not strongly affect the system operation
913 making the detection process less sensible to its presence. This result agreed with the findings of the
914 ASHRAE-RP 1312 project, during which the analysed dataset was generated [14].

915 The last group includes days in Figure 11 (b) and (l) that are characterized by a similar amount of
916 violated and not violated rules (violation rate between 40% and 60%). These two faults seem to affect
917 the performance of the system differently from other faults respect to which hypothetically should
918 exhibit high similarity (i.e., CCVS15 and RFF30). Regarding the fault CCVS65 (Figure 11 (b)), the
919 cooling coil valve is stuck open at 65% and therefore the supply air flow is overcooled. In this case,
920 the system reacts by opening the heating coil valve and operating in fully recirculation mode for
921 increasing the *supply air temperature* (SA_TEMP). Consequently, the failure of the cooling coil valve
922 does not affect the capability of the system in reaching the supply set-point temperature, but the
923 operation of the other components is different from the normal condition.

924 On the opposite, during the day (Figure 11 (a)) tagged as CCVS15 (included in group 2) the cooling
925 coil valve is almost closed limiting the heat transfer with the supply air flow that does not reach the
926 set point temperature. Such case is representative of the complete failure of the system in maintaining
927 the desired conditions of the indoor environment, as a matter of fact, justifying a higher rule violation
928 rate for CCVS15 respect to CCVS65.

929 Regarding the fault RFCF (Figure 11 (l)), the system is operated implementing the complete failure
930 of the return fan despite its speed control signal is correctly elaborated. Instead, during the day in
931 Figure 11 (m) tagged as RFF30 (included in group 2), the return fan is not corrupted, but it is subjected
932 to a faulty control signal. In this case the high number of rules violated for RFF30 suggests a higher
933 sensitivity of the extracted rules to frequent transitions of the fan speed discrete values rather than fan
934 power ones.

935 Some key figures related to the 465 extracted rules are described below. The rules are characterized
936 by an ACTUAL TIME LAG that lies between 15 and 30 minutes. The evaluation of the ACTUAL
937 TIME LAG can be considered as an essential step for reducing the intrinsic latency of the FDD

938 process during real implementation. Indeed, the ACTUAL TIME LAG gives the opportunity to check
 939 the occurrence of a rule within a time interval smaller than the width of the sliding window used for
 940 the rule extraction (in this case study, equal to 60 min.).

941 The transitions in the antecedent and consequent item sets are reported in Table 3 with the
 942 corresponding occurrence frequency. In particular, the number of different consequent item sets is
 943 13, resulting from a combination of 4 different events, while the antecedent item sets are 99, resulting
 944 from the combination of 12 different events.

945 *Table 3. Occurrence frequency of each event included in the antecedent and consequent item sets*

Itemset	Variable	Event	Frequency
Antecedent	Return Fan Speed	RF_SPD [A-B]	87%
	Cooling coil input water temperature	CHWC_EWT [D-C]	31%
	Return fan power	RF_WAT [A-B]	24%
	Exhaust air damper position	EA_DMPPR [A-B]	23%
	Cooling coil output water temperature	CHWC_LWT [C-B]	22%
	Supply fan speed	SF_SPD [A-B]	22%
	Cooling coil input water temperature	CHWC_EWT [C-A]	21%
	Supply fan power	SF_WAT [A-B]	21%
	Return fan start/stop signal	RF_SST [A-B]	18%
	Return air flow rate	RA_CFM [A-B]	16%
	Return fan pressure drop	RF_DP [A-B]	12%
	Return fan pressure drop	SF_DP [A-B]	9%
Consequent	Return Fan Speed	RF_SPD [B-C]	87%
	Supply Air Temperature	SA_TEMP [B-A]	49%
	Cooling coil output water temperature	CHWC_LWT [B-A]	46%
	Cooling coil air temperature	CHWC_DAT [B-A]	36%

946

947 The obtained rule set, including the most representative rules, is reported in Table B in Appendix A.

948 The rules extracted are meaningful since they can be interpreted as chains of events that characterise
 949 the normal operation of the AHU in reaching the set-point conditions during the start-up period.

950 Indeed, extracted rules can be expressed as IF-THEN implications to be verified within a specific
 951 time interval. As a reference, the rule n° 8661 (included in Table B in Appendix A) can be written
 952 and interpreted as follow: IF (RF_SPD [A-B] and CHWC_LWT [C-B] and EA_DMPPR [A-B]) occur
 953 THEN (CHWC_DAT [B-A] and RF_SPD [B-C]) will occur within 30 minutes with the 100% of
 954 confidence during a normal day.

955 In detail, the antecedent itemset includes transitions related to the return fan speed (RF_SPD), the
956 *cooling coil output water temperature* (CHWC_LWT) and the *exhaust air damper position*
957 (EA_DMPPR) that imply the occurrence of consequent transitions related to *cooling coil output water*
958 *temperature* (CHWC_LWT) and *return fan speed* (RF_SPD).

959 In order to further improve the interpretability of the rules a novel visualization was proposed in this
960 work. An example of this visualization is showed in Figure 12, where the profiles of the variables
961 involved in rule n°1253 (see Table B in Appendix A).

962 Figure 12 shows the trend of the variables in terms of real profile (i.e. green curve) and PAA (i.e.
963 black segments). Regardless of the approximation introduced by the PAA, the behaviour of the
964 variables during the transient period is preserved, as can be seen by looking at the *supply air*
965 *temperature* trend (SA_TEMP). In fact, during the start-up period the *supply fan speed* (SF_SPD)
966 initially ramps up and then it is reduced to a constant level. The transitions of the antecedent itemset
967 are reported in red, while the consequent itemset in blue. The PAA is represented in a window of 60
968 minutes, while with a darker shade of grey the length of the ACTUAL TIME LAG (i.e., 15 minutes)
969 is reported. On the y-axis are shown the values used for the discretization of each variable.

970 The rule in Figure 12 shows a typical behaviour of the system at the start-up period, in terms of the
971 variation of *supply fan speed* (SF_SPD), *exhaust air damper* (EA_DMPPR), *return fan power*
972 (RF_WAT), and *supply air temperature* (SA_TEMP).

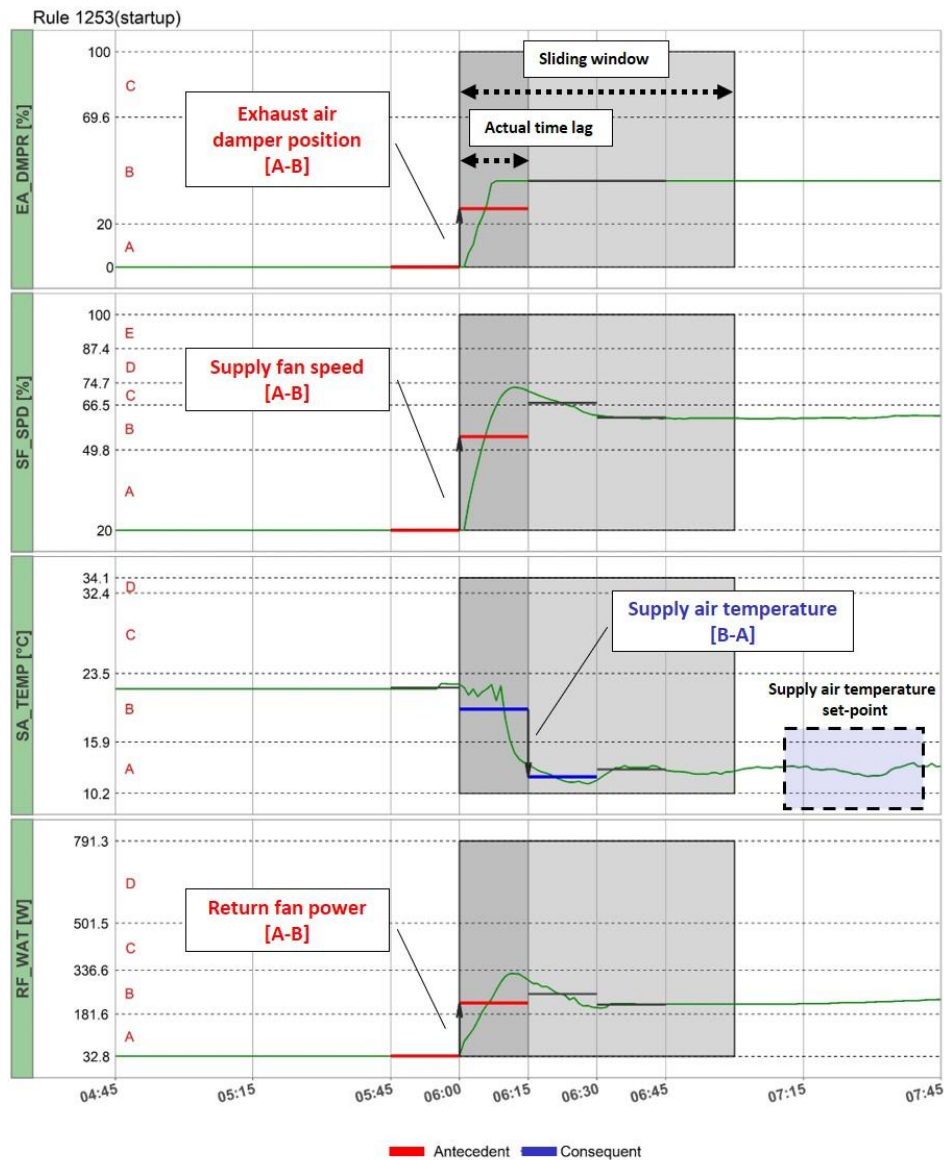

973

974 *Figure 12. Visualization of an extracted temporal association rule (refer to Table 2 for variable encoding).*

975 According to this rule, usually at the time scheduled for the start-up (i.e. 6:00 a.m.), the supply fan
 976 receives the start signal contemporary to the opening of the exhaust air damper while the *return fan*
 977 *power* (RF_WAT) increases (change from A to B). After 15 minutes from the occurrence of the first
 978 antecedent transition in the event chain, according to the rule, the *supply air temperature* (SA_TEMP)
 979 decreases from symbolic discrete-value B to A until the reaching of the desired set-point.

980 This proved that the chain of events related to each association rule provides information about the
 981 expected behaviour in terms of discrete-value changes among influencing variables of the AHU
 982 during normal operation.

983 6.3 Fault detection and diagnosis during non-transient period

984 In this section, the results obtained for the application of the methodology during non-transient period
 985 described in section 5 are presented. The first step is aimed at developing a CT reference model for
 986 each variable to predict the normal operation of the system. For the development of these reference
 987 estimation models, all the variables related to the operation of the AHU have been selected once at a
 988 time as target attribute while the remaining ones have been used as input attributes. However, features
 989 related to external forcing variables to the AHU system (i.e., *cooling coil input water temperature*
 990 (*CHWC_EWT*), *outdoor air temperature* (*OA_TEMP*)) have been used only as input attributes. As a
 991 result, 21 reference models were built for providing a robust benchmark of fault-free operation.
 992 Moreover, the variables used as input were also considered with a maximum backward lag of four
 993 time steps (i.e. 60 minutes). Indeed, the decision trees are able to predict the discrete values (i.e.,
 994 symbol) of a target variable considering the discrete values of the input variables both in the same
 995 and previous aggregation intervals.

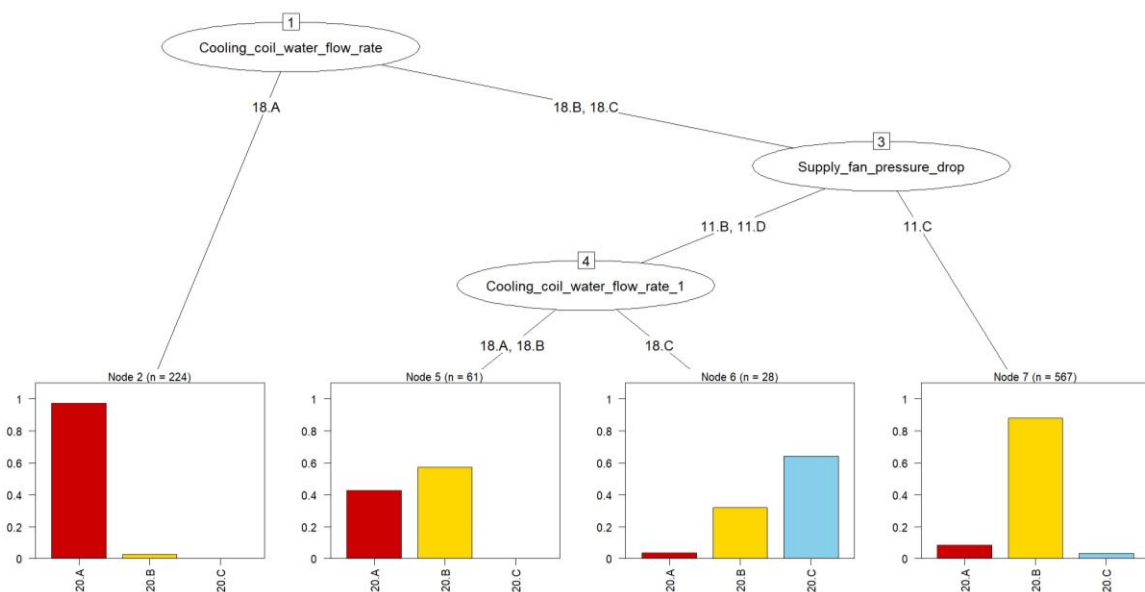

996
 997 *Figure 13. Classification tree for the estimation of the symbolic discrete-values of the cooling coil valve position*
 998 *(CHWC_VLV).*

999 Figure 13 reports as an example the CT model developed for predicting the discrete values (i.e.,
 1000 symbol) of the variable *cooling coil water valve position* (i.e., variable tagged as *CHWC_VLV* with

1001 ID n° = 20), with an overall accuracy of 88% evaluated as the fraction of correct predictions with
 1002 respect to the total number of predictions. The algorithm selected as input variables the *cooling coil*
 1003 *water flow rate* (i.e., variable tagged as CHWC_GPM with ID n° = 18) and the *pressure drop of the*
 1004 *supply fan* (i.e., variable tagged as SF_DP with ID n° = 11). From this CT, it is possible to extract
 1005 useful decision rules for straightforwardly characterizing all the implications between discrete values
 1006 (i.e., symbols) that typically occur during the fault-free operation of the AHU. Table 4 reports all the
 1007 IF-THEN decision rules extracted from the CT shown in Figure 13 with the evidence of the accuracy
 1008 achieved in each leaf node. The accuracy refers to each single leaf node assuming that the predicted
 1009 label of the node corresponds to the label of the majority of the objects.

1010 For example, according to rule 4, the value of the response variable *cooling coil valve position* is
 1011 equal to 20_B (i.e. CHWC_VLV lies in the interval 41 – 75 [%]) if the *cooling coil water flow rate*
 1012 is equal to 18_B or 18_C (i.e. CHWC_GPM lies in the interval 0,89 – 2.7 [m³/h]) and the *supply fan*
 1013 *pressure drop* is equal to 11_C (i.e. SF_DP lies in the interval 562 – 770 [Pa]).

1014 *Table 4. Decision rules for the estimation of the symbolic discrete-value of cooling coil valve position (CHWC_VLV).*

Rule number	Decision rules	CHWC_VLV discrete-value	N° of objects	Leaf node accuracy
1)	IF CHWC_GPM = 18_A	20_A	224	95%
2)	IF CHWC_GPM = 18_B or 18_C AND SF_DP = 11_B or 11_D AND CHWC_GPM (lag -1) = 18_A or 18_B	20_B	61	55%
3)	IF CHWC_GPM = 18_B or 18_C AND SF_DP = 11_B or 11_D AND CHWC_GPM (lag -1) = 18_C	20_C	28	65%
4)	IF CHWC_GPM = 18_B or 18_C AND SF_DP = 11_C	20_B	567	85%

1015 Once all the estimation models were trained and validated, the residual analysis was performed by
 1016 using a testing dataset including both faulty and fault-free data (i.e., 2 fault-free and 11 faulty days).
 1017 Therefore, the difference between the actual status of a variable and that estimated by the CT during
 1018 a aggregation interval determines the detection or not of a potential faulty condition, since the
 1019 predicted status should be considered as the reference condition (fault-free). The values of the

1020 residuals can be equal to zero in case of absence of deviation from the normal conditions, positive if
 1021 the actual value is higher than expected, while negative if the actual value is lower than expected.
 1022 Eventually, in order to perform fault diagnosis, an additional CT model was developed, which uses
 1023 in input the residuals obtained from the estimation performed through the previously described
 1024 reference models and as output the tags related to the various faults analysed in this study.
 1025 Figure 14 shows the classification model obtained, which can classify the faults considered with a set
 1026 of intuitive rules, reaching an overall accuracy of the 90%.

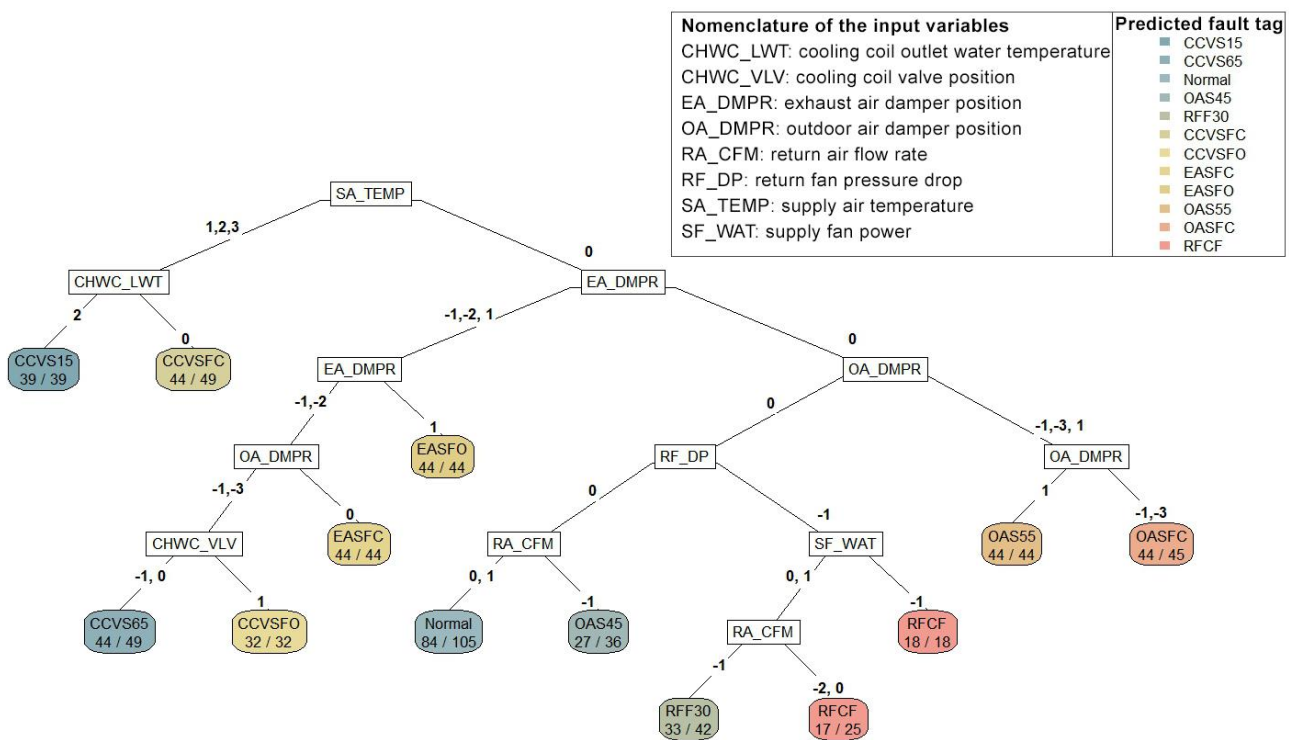

1027
 1028 *Figure 14. Classification tree for the fault diagnosis during the non-transient period.*

1029 The variables involved in input for the classification are the *supply air temperature* (SA_TEMP), the
 1030 *outdoor air damper position* (OA_DMPR), the *exhaust air damper position* (EA_DMPR), the *cooling*
 1031 *coil outlet water temperature* (CHWC_LWT), the *cooling coil valve position* (CHWC_VLV), the
 1032 *supply fan power* (SF_WAT), the *return fan pressure drop* (RF_DP) and the *return air flow rate*
 1033 (RA_CFM). The CT developed can diagnose 11 different faults and the normal condition as well.
 1034 The latter is predicted by following the path of the CT (Figure 14) that includes all zeros (i.e. residual
 1035 equal to zero) in the splits for the variables SA_TEMP, EA_DMPR, OA_DMPR, RF_DP and
 1036 RA_CFM. With reference to Figure 14, some other rules are described in the following.

1037 The first split made by the CT algorithm is driven by the *supply air temperature* (SA_TEMP), which
1038 identifies the faults due to a blockage of the cooling coil valve at 0% (CCSFC) or at 15% (CCVS15)
1039 if the air temperature presents higher values than normal (i.e., SA_TEMP residuals = 1, 2, 3).

1040 In some cases, the faults can be diagnosed by analysing the variables directly related to the corrupted
1041 component, such as the blockage of the exhaust and outdoor air dampers at 0%, 55% or 100% (i.e.
1042 OASFC, OAS55, EASFC, and EASFO). In other cases, a series of deviation from the normal
1043 condition for different variables are considered as symptoms for a specific fault. That is the case, for
1044 example, of anomalous energy transfer in the cooling coil due to blockage of the cooling coil valve
1045 at 65% (CCVS65) or 100% (CCVSFO). These faults are diagnosed in the case both the air dampers
1046 are completely closed (i.e. negative values of residuals), but the *supply air temperature* (SA_TEMP)
1047 does not present a deviation from the normal condition. In this case, the system tries to counterbalance
1048 the excessive decrease of the temperature of the air by operating in fully recirculation mode.

1049 The effect of a fault related to the return fan (Figure 14) can be easily identified, since the pressure
1050 drop at the return fan is reduced, with the absence of deviation, from normal condition, for *supply air*
1051 *temperature* (SA_TEMP) and air dampers.

1052 The discrimination between the *return fan complete failure* (RFCF) and the case when the speed is
1053 fixed at 30% (RFF30) can be performed by evaluating the severity of the reduction of the *return air*
1054 *flow rate* (RA_CFM) rather than the reduction of the *supply fan power* (SF_WAT).

1055 The introduced FDD tool is a multiclass classifier and when in operation sorts data into either fault-
1056 free (i.e., normal) or faulty classes.

1057 All the evaluation metrics for a multiclass classification model can be understood in the context of a
1058 binary classification model (where the classes are “positive” and “negative”). These metrics are
1059 derived from the following categories:

- 1060 • True Positives (TP): Objects labelled as positive and predicted to be positive.
- 1061 • False Positives (FP): Objects labelled as negative and predicted to be positive.
- 1062 • True Negatives (TN): Objects labelled as negative and predicted to be negative.

1063 • False Negatives (FN): Objects labelled as positive and predicted to be negative.

1064 The multiclass classification problem can be seen as a set of many binary classification problems and
1065 its performance can be assessed labelling as “positive” each class once at time. In the context of the
1066 presented multiclass FDD classifiers some metrics have been calculated:

1067 • Accuracy (A): Objects of items correctly identified as either truly positive or truly negative
1068 out of the total number of items i.e., $(TP + TN)/(TP + TN + FP + FN)$.

1069 • Recall (R): Number of objects correctly identified as positive out of the total actual positives
1070 i.e., $TP/(TP + FN)$. The recall is calculated for each class and then averaged among classes
1071 for a global performance assessment of the CT.

1072 • Precision (P): Number of objects correctly identified as positive out of the total items
1073 predicted as positive i.e., $TP/(TP + FP)$. The precision is calculated for each class and then
1074 averaged among classes for a global performance assessment of the CT.

1075 • False Positive Rate (FPR), Type I error: Number of objects wrongly identified as faulty out
1076 of the total actual fault-free data i.e., $FP/(FP + TN)$. In FDD processes, this error means that
1077 data belonging to fault-free class (negative) are incorrectly labelled as faulty (positives)
1078 generating false alarms.

1079 • False Negative Rate (FNR), Type II error : Number of objects wrongly predicted as fault-free
1080 out of the total actual faulty data i.e., $FN/(FN + TP)$. In FDD processes, this error means that
1081 data belonging to one of the fault classes (positives) are incorrectly labelled as fault-free
1082 (negative) generating missing detection opportunities.

1083 The developed CT exhibits the following performances $A = 90\%$, $R = 89\%$, $P = 91\%$, $FNR = 4\%$,
1084 $FPR = 4\%$. The performance of the CT can be also assessed with the detail of each class considered.
1085 To this purpose, in Table 5 is reported the Confusion Matrix (CM) of the CT. The CM, in form of
1086 table (actual class vs predicted class), allows an effective analysis of the performance of the CT
1087 algorithm making it possible to identify confusion between all the considered classes (i.e.,
1088 mislabelling of objects belonging to a class and classified into another one).

1089 In particular, rows of the table correspond to the actual classes while columns to the predicted ones.
 1090 At this stage it is possible to evaluate in each class the proportion of prediction actually correct (i.e.,
 1091 Precision) and the proportion of actual values predicted correctly (i.e., Recall).

1092 *Table 5. Precision and recall for classification tree of fault diagnosis during non-transient period.*

	CCVS15	CCVS65	Normal	OAS45	RFF30	CCVSFC	CCVSFO	EASFC	EASFO	OAS55	OASFC	RFCF	Total	Recall
CCVS15	39	0	0	0	0	5	0	0	0	0	0	0	44	89%
CCVS65	0	44	0	0	0	0	0	0	0	0	0	0	44	100%
Normal	0	0	84	3	0	0	0	0	0	0	1	0	88	96%
OAS45	0	0	17	27	0	0	0	0	0	0	0	0	44	61%
RFF30	0	0	2	1	33	0	0	0	0	0	0	8	44	75%
CCVSFC	0	0	0	0	0	44	0	0	0	0	0	0	44	100%
CCVSFO	0	5	2	5	0	0	32	0	0	0	0	0	44	73%
EASFC	0	0	0	0	0	0	0	44	0	0	0	0	44	100%
EASFO	0	0	0	0	0	0	0	0	44	0	0	0	44	100%
OAS55	0	0	0	0	0	0	0	0	0	44	0	0	44	100%
OASFC	0	0	0	0	0	0	0	0	0	0	44	0	44	100%
RFCF	0	0	0	0	9	0	0	0	0	0	0	35	44	80%
Total	39	49	105	36	42	49	32	44	44	44	45	43	572	Average 89%
Precision	100%	90%	80%	75%	79%	90%	100%	100%	100%	100%	98%	81%	Average 91%	

1093
 1094 Thanks to the methodology introduced in the present paper the faults in the dataset were diagnosed
 1095 with both high precision and recall, as can be seen in Table 5. The lowest values of precision and
 1096 recall are related to the fault *outdoor air damper stuck at 45%* (OAS45), for which part of the records
 1097 have been mislabelled as “Normal” (i.e., 17 out of 44 objects, that correspond to the 39% of data
 1098 labelled as OAS45 and to the 89% of the total amount of False Negatives). This condition is due to
 1099 the fact that the outdoor air damper stuck open at 45% does not invalidate the operation of the system
 1100 which is similar to the fault-free one during the non-transient period. It is worth nothing that all the
 1101 assumptions taken, and results obtained are related to a specific operative condition of the system
 1102 (i.e., cooling mode). The set of rules extracted can be then considered a valid FDD solution if only
 1103 applied on data consistent with the initial hypotheses. Despite this, even though the analysis is related
 1104 to a portion of the possible operative conditions of an AHU, the performance achieved suggests good
 1105 perspectives in applicability and generalizability of the proposed methodology.

7 Discussion and concluding remarks

The paper introduces a data-driven based methodology to perform an AFDD in AHUs. Two different analytics modules were proposed for transient and non-transient conditions of the AHU operation and consequently to enhance the energy performance of the ventilation and air-conditioning process. The dataset used for testing the methodology includes several faulty and fault-free running conditions related to the cooling operative mode of AHUs. Data were gathered from monitoring campaign on two identical AHUs in the framework of the Research Project ASHRAE RP-1312.

The fault detection during the start-up period was performed with an innovative approach by searching frequent and non-anomalous relationships between events in a temporal transaction set using temporal association rules. A temporal association rule is expressed as a logical IF-THEN implication where the presence of an event (i.e., antecedent) implies the occurrence of another event (i.e., consequent) within a certain time lag. According to this approach, in the analysed case study the violation of a rule or group of rules may suggest the occurrence of abnormal conditions during system operation. Three potential rule violations have been considered for detecting faults during the start-up period: i) absence of the antecedent, ii) absence of consequent, iii) absence of antecedent and consequent.

The used rules are extracted by expert knowledge from a large set of possible rules and are representative of the normal operation of the AHU and are characterised by high physical interpretability. The introduction of innovative parameters (e.g. SUPP.DAY in faulty and normal conditions, support and confidence in the ACTUAL TIME LAG) allowed a robust selection of the most interesting association rules, minimising the effort required in the post-processing stage. Furthermore, an effective visualization of the temporal association rules was introduced with the aim of supporting energy managers in the interpretation of the temporal associations between operational variables in real-time.

The AFDD during non-transient period was performed by training and testing 21 CT models for providing a robust benchmark of the fault-free operation. The CT models are able to predict the

1132 discrete values of a target operational variable considering the values of the input variables both in
1133 the same and previous aggregation interval. The CTs showed high performance (i.e., high accuracy,
1134 precision and recall) in modeling all the variable relations that are characteristic of the operative
1135 condition of interest (i.e., 20 days of AHU operated in cooling mode).

1136 Eventually, an additional CT was developed in order to perform fault diagnosis. The model showed
1137 an overall accuracy of 90% and consists of a set of intuitive rules easy to be implemented for detecting
1138 up to 11 typical faults in AHUs. However, the set of rules extracted can be then considered as a valid
1139 FDD solution only if applied on data consistent with the initial hypotheses (i.e., AHU operated in
1140 cooling mode).

1141 Overall, the results obtained are characterised by robustness and high interpretability proving the
1142 effectiveness of the proposed methodology for ensuring a correct energy and operational management
1143 of the ventilation and air-conditioning process.

1144 Even though the rule set and the classification models are tailored for the case study analysed, the
1145 outcomes of the process can be considered flexible and generalizable. The methodologies were
1146 conceived for being automatic and for effectively managing the redundancy, interpretability and
1147 physical meaningfulness of the association and classification rules. Moreover, the proposed AFDD
1148 process is conceived for quasi real-time implementation, also minimising the user contribution and
1149 paying attention to the optimisation of computational cost. To this purpose, the preliminary
1150 discretisation of the variables, performed through the aSAX algorithm, proved to be particularly
1151 effective in extracting the crucial operational conditions of the AHU reaching the optimal trade-off
1152 between data reduction and information loss. Moreover, the association rules were extracted from an
1153 event-based dataset (i.e., database of transactions) where only information about the discrete-value
1154 changes of the operational variables is stored. As a consequence, the computational cost related to
1155 the mining of rules is strongly reduced, increasing the feasibility of such approach in real case studies.
1156 As a reference the whole analytics process takes about 45 min in terms of computational time on a

1157 computer equipped with quad-core processor Intel i7-3632QM CPU (2.20GHz) and 8GB RAM
1158 DDR4. In more detail the rule extraction phase takes more or less 10 minutes. It means that the most
1159 onerous parts of the analysis are represented by the pre-processing and post-mining phases. In the
1160 pre-processing phase the assessment of the optimal quantization of the time series through aSAX is
1161 validated by using more than 20 metrics (cluster validity indices included in the R Nbclust package
1162 [68]). Such calculation takes more than 10 minutes. In the post mining phase, the recalculation of
1163 support and confidence of each rule within the evaluated ACTUAL TIME LAG (instead of the
1164 window of 60-min), and the violation analysis performed on the testing dataset take about 20 minutes.
1165 For what concern the analysis of non-transient data, the development of each classification tree takes
1166 few seconds of computation and can be considered a task easily parallelizable. As a result, the impact
1167 of the analysis of non-transient data can be considered negligible in terms of computational cost
1168 compared to the pre-processing, rule extraction and rule post-mining. Indeed, in the perspective of a
1169 real-time implementation of the whole AFDD process, the update of the discretization intervals, set
1170 of association rules and estimation models can be accomplished during night-time while the fault
1171 detection and diagnosis tool can be run online during operation. For what concern the pre-processing
1172 stage, during the real-time operation the Hampel filter can still be used but considering that its
1173 intrinsic latency equal to $(Len-1)/2$ should be added to the latency of the FDD process in detecting
1174 faults (in this case study the latency of the FDD process is equal to the length of the aggregation
1175 interval i.e., 15 min). For avoiding high latency in the analysis, Len can be reduced. As an alternative,
1176 other pre-processing algorithms, particularly suitable for the analysis of data streams, can be
1177 employed for detecting statistical outliers in real-time (i.e., before time $t + 1$ and without any look
1178 ahead) [71]. Further research will be then conducted to assess the scalability of the methodology to
1179 other operation modes and systems and to integrate it with knowledge driven-based analysis for better
1180 addressing the implementation issues characteristic of data-driven tools. Indeed, data-driven based
1181 FDD tools need a proper amount of data for the development of diagnosis models and cannot
1182 extrapolate beyond the range of training data [10]. It means that their capability in automatically

1183 extracting pattern from actual performance data is strictly related to the availability of pre-labelled
1184 monitored data (typically derived from AHU recommissioning or simulated data). On the contrary,
1185 knowledge driven-based approach can introduce domain knowledge and user experience into the
1186 FDD process [10], especially in the case initial information is not enough for deploying a data-driven
1187 process. In this perspective, a perfect integration of both approaches represents the main opportunity
1188 for significantly improve robustness, accuracy and generalizability of FDD tools conceived for
1189 application in building energy systems.

1190 **8 Acknowledgements**

1191 Particular thanks to ASHRAE for the permission given for the use of the data and documents from
1192 ASHRAE RP-1312.

1193 © ASHRAE www.ashrae.org (“ASHRAE RP-1312 Tools for Evaluating Fault Detection and
1194 Diagnostic Methods for Air-Handling Units.”), (2011).

1195 **References**

- 1196 [1] A. Capozzoli, T. Cerquitelli, M.S. Piscitelli, Chapter 11 – Enhancing energy efficiency in
1197 buildings through innovative data analytics technologies, in: D. Ciprian, F. Xhafa (Eds.),
1198 Pervasive Comput., 2016: pp. 353–389. [https://doi.org/10.1016/B978-0-12-803663-1.00011-](https://doi.org/10.1016/B978-0-12-803663-1.00011-5)
1199 5.
- 1200 [2] L. Pérez-Lombard, J. Ortiz, C. Pout, A review on buildings energy consumption information,
1201 Energy Build. 40 (2008) 394–398. <https://doi.org/10.1016/j.enbuild.2007.03.007>.
- 1202 [3] Office of Energy Efficiency & Renewable Energy (EERE) U.S. Department of Energy, DOE
1203 Office of Energy Efficiency and Renewable Energy, Buildings energy databook, 2012.
1204 <http://buildingsdatabook.eren.doe.gov/DataBooks.aspx>.
- 1205 [4] J. Proctor, Residential and Small Commercial Central air Conditioning; Rated Efficiency isn't
1206 Automatic, Present. Public Sess. ASHRAE Winter Meet. (2004).
- 1207 [5] K. Yan, C. Zhong, Z. Ji, J. Huang, Semi-supervised learning for early detection and diagnosis

- 1208 of various air handling unit faults, *Energy Build.* 181 (2018) 75–83.
1209 <https://doi.org/10.1016/j.enbuild.2018.10.016>.
- 1210 [6] R. Isermann, *Fault-Diagnosis Systems: an introduction from fault detection to fault tolerance*,
1211 Springer Science & Business Media, 2006. <https://doi.org/10.1007/3-540-30368-5>.
- 1212 [7] J. Granderson, G. Lin, R. Singla, E. Mayhorn, P. Ehrlich, D. Vrabie, *Commercial Fault*
1213 *Detection and Diagnostics Tools: What They Offer, How They Differ, and What’s Still*
1214 *Needed*, 2018. <https://doi.org/10.20357/B7V88H>.
- 1215 [8] H. Kramer, G. Lin, J. Granderson, C. Curtin, E. Crowe, *Synthesis of Year One Outcomes in*
1216 *the Smart Energy Analytics Campaign Building Technology and Urban Systems Division*,
1217 (2017).
- 1218 [9] W. Kim, S. Katipamula, *A review of fault detection and diagnostics methods for building*
1219 *systems*, *Sci. Technol. Built Environ.* 24 (2018) 3–21.
1220 <https://doi.org/10.1080/23744731.2017.1318008>.
- 1221 [10] Y. Zhao, T. Li, X. Zhang, C. Zhang, *Artificial intelligence-based fault detection and diagnosis*
1222 *methods for building energy systems: Advantages, challenges and the future*, *Renew. Sustain.*
1223 *Energy Rev.* 109 (2019) 85–101. <https://doi.org/10.1016/j.rser.2019.04.021>.
- 1224 [11] C. Fan, F. Xiao, Z. Li, J. Wang, *Unsupervised data analytics in mining big building operational*
1225 *data for energy efficiency enhancement: A review*, *Energy Build.* 159 (2018) 296–308.
1226 <https://doi.org/10.1016/j.enbuild.2017.11.008>.
- 1227 [12] Y. Yu, D. Woradechjumroen, D. Yu, *A review of fault detection and diagnosis methodologies*
1228 *on air-handling units*, *Energy Build.* 82 (2014) 550–562.
1229 <https://doi.org/10.1016/j.enbuild.2014.06.042>.
- 1230 [13] A. Beghi, R. Brignoli, L. Cecchinato, G. Menegazzo, M. Rampazzo, F. Simmini, *Data-driven*
1231 *Fault Detection and Diagnosis for HVAC water chillers*, *Control Eng. Pract.* 53 (2016) 79–91.
1232 <https://doi.org/10.1016/j.conengprac.2016.04.018>.
- 1233 [14] S. Wen, Jin; Li, *ASHRAE 1312-RP Tools for Evaluating Fault Detection and Diagnostic*

- 1234 Methods for Air-Handling Unit [FINAL REPORT], (2011) 13.
1235 <http://marketingdatabase.tat.or.th/download/article/research/1201finalreport.pdf>.
- 1236 [15] D. Dehestani, F. Eftekhari, Y. Guo, S. Ling, S. Su, H. Nguyen, Online Support Vector Machine
1237 Application for Model Based Fault Detection and Isolation of HVAC System, *Int. J. Mach.*
1238 *Learn. Comput.* 1 (2011) 66–72. <https://doi.org/10.7763/ijmlc.2011.v1.10>.
- 1239 [16] Y. Zhao, J. Wen, F. Xiao, X. Yang, S. Wang, Diagnostic Bayesian networks for diagnosing air
1240 handling units faults – part I: Faults in dampers, fans, filters and sensors, *Appl. Therm. Eng.*
1241 111 (2017) 1272–1286. <https://doi.org/10.1016/j.applthermaleng.2015.09.121>.
- 1242 [17] Y. Zhao, J. Wen, S. Wang, Diagnostic Bayesian networks for diagnosing air handling units
1243 faults - Part II: Faults in coils and sensors, *Appl. Therm. Eng.* 90 (2015) 145–157.
1244 <https://doi.org/10.1016/j.applthermaleng.2015.07.001>.
- 1245 [18] T. Mulumba, A. Afshari, K. Yan, W. Shen, L.K. Norford, Robust model-based fault diagnosis
1246 for air handling units, *Energy Build.* 86 (2015) 698–707.
1247 <https://doi.org/10.1016/j.enbuild.2014.10.069>.
- 1248 [19] R. Yan, Z. Ma, Y. Zhao, G. Kokogiannakis, A decision tree based data-driven diagnostic
1249 strategy for air handling units, *Energy Build.* 133 (2016) 37–45.
1250 <https://doi.org/10.1016/j.enbuild.2016.09.039>.
- 1251 [20] M.K. Mchugh, Data-Driven Leakage Detection in Air-Handling Units on a University
1252 Campus, *ASHRAE Annu. Conf.* (2019).
- 1253 [21] Z. Yu, F. Haghghat, B.C.M. Fung, L. Zhou, A novel methodology for knowledge discovery
1254 through mining associations between building operational data, *Energy Build.* 47 (2012) 430–
1255 440. <https://doi.org/10.1016/j.enbuild.2011.12.018>.
- 1256 [22] P. Xue, Z. Zhou, X. Fang, X. Chen, L. Liu, Y. Liu, J. Liu, Fault detection and operation
1257 optimization in district heating substations based on data mining techniques, *Appl. Energy.*
1258 205 (2017) 926–940. <https://doi.org/10.1016/j.apenergy.2017.08.035>.
- 1259 [23] C. Zhang, X. Xue, Y. Zhao, X. Zhang, T. Li, An improved association rule mining-based

- 1260 method for revealing operational problems of building heating, ventilation and air conditioning
1261 (HVAC) systems, *Appl. Energy.* 253 (2019) 113492.
1262 <https://doi.org/10.1016/j.apenergy.2019.113492>.
- 1263 [24] C. Fan, F. Xiao, H. Madsen, D. Wang, Temporal knowledge discovery in big BAS data for
1264 building energy management, *Energy Build.* 109 (2015) 75–89.
1265 <https://doi.org/10.1016/j.enbuild.2015.09.060>.
- 1266 [25] C. Fan, Y. Sun, K. Shan, F. Xiao, J. Wang, Discovering gradual patterns in building operations
1267 for improving building energy efficiency, *Appl. Energy.* 224 (2018) 116–123.
1268 <https://doi.org/10.1016/j.apenergy.2018.04.118>.
- 1269 [26] A. Capozzoli, F. Lauro, I. Khan, Fault detection analysis using data mining techniques for a
1270 cluster of smart office buildings, *Expert Syst. Appl.* 42 (2015) 4324–4338.
1271 <https://doi.org/10.1016/j.eswa.2015.01.010>.
- 1272 [27] I. Khan, A. Capozzoli, S.P. Corgnati, T. Cerquitelli, Fault detection analysis of building energy
1273 consumption using data mining techniques, *Energy Procedia.* 42 (2013) 557–566.
1274 <https://doi.org/10.1016/j.egypro.2013.11.057>.
- 1275 [28] M. Dey, S.P. Rana, S. Dudley, Smart building creation in large scale HVAC environments
1276 through automated fault detection and diagnosis, *Futur. Gener. Comput. Syst.* (2018).
1277 <https://doi.org/10.1016/j.future.2018.02.019>.
- 1278 [29] Z. Du, X. Jin, Y. Yang, Fault diagnosis for temperature, flow rate and pressure sensors in VAV
1279 systems using wavelet neural network, *Appl. Energy.* 86 (2009) 1624–1631.
1280 <https://doi.org/10.1016/j.apenergy.2009.01.015>.
- 1281 [30] Z. Du, B. Fan, X. Jin, J. Chi, Fault detection and diagnosis for buildings and HVAC systems
1282 using combined neural networks and subtractive clustering analysis, *Build. Environ.* 73 (2014)
1283 1–11. <https://doi.org/10.1016/j.buildenv.2013.11.021>.
- 1284 [31] Y. Guo, J. Wall, J. Li, S. West, Intelligent Model Based Fault Detection and Diagnosis for
1285 HVAC System Using Statistical Machine Learning Methods, in: ASHRAE 2013 Winter Conf.,

- 1286 2013: pp. 1–8.
- 1287 [32] S. Li, J. Wen, A model-based fault detection and diagnostic methodology based on PCA
1288 method and wavelet transform, *Energy Build.* 68 (2014) 63–71.
1289 <https://doi.org/10.1016/j.enbuild.2013.08.044>.
- 1290 [33] X. Jin, Z. Du, Fault tolerant control of outdoor air and AHU supply air temperature in VAV
1291 air conditioning systems using PCA method, *Appl. Therm. Eng.* 26 (2006) 1226–1237.
1292 <https://doi.org/10.1016/j.applthermaleng.2005.10.039>.
- 1293 [34] J. Liang, R. Du, Model-based Fault Detection and Diagnosis of HVAC systems using Support
1294 Vector Machine method, *Int. J. Refrig.* 30 (2007) 1104–1114.
1295 <https://doi.org/10.1016/j.ijrefrig.2006.12.012>.
- 1296 [35] S. Wu, J.Q. Sun, Cross-level fault detection and diagnosis of building HVAC systems, *Build.*
1297 *Environ.* 46 (2011) 1558–1566. <https://doi.org/10.1016/j.buildenv.2011.01.017>.
- 1298 [36] W.Y. Lee, J.M. House, N.H. Kyong, Subsystem level fault diagnosis of a building's air-
1299 handling unit using general regression neural networks, *Appl. Energy.* 77 (2004) 153–170.
1300 [https://doi.org/10.1016/S0306-2619\(03\)00107-7](https://doi.org/10.1016/S0306-2619(03)00107-7).
- 1301 [37] D. Dey, B. Dong, A probabilistic approach to diagnose faults of air handling units in buildings,
1302 *Energy Build.* 130 (2016) 177–187. <https://doi.org/10.1016/j.enbuild.2016.08.017>.
- 1303 [38] D. Li, Y. Zhou, G. Hu, C.J. Spanos, Optimal Sensor Configuration and Feature Selection for
1304 AHU Fault Detection and Diagnosis, *IEEE Trans. Ind. Informatics.* 13 (2017) 1369–1380.
1305 <https://doi.org/10.1109/TII.2016.2644669>.
- 1306 [39] S. Li, J. Wen, Application of pattern matching method for detecting faults in air handling unit
1307 system, *Autom. Constr.* 43 (2014) 49–58. <https://doi.org/10.1016/j.autcon.2014.03.002>.
- 1308 [40] K. Yan, J. Huang, W. Shen, Z. Ji, Unsupervised learning for fault detection and diagnosis of
1309 air handling units, *Energy Build.* 210 (2020) 109689.
1310 <https://doi.org/10.1016/j.enbuild.2019.109689>.
- 1311 [41] Y. Yan, P.B. Luh, K.R. Pattipati, Fault diagnosis of HVAC: Air delivery and terminal systems,

- 1312 IEEE Int. Conf. Autom. Sci. Eng. 2017-Augus (2017) 882–887.
1313 <https://doi.org/10.1109/COASE.2017.8256214>.
- 1314 [42] C. Zhong, K. Yan, Y. Dai, N. Jin, B. Lou, Energy efficiency solutions for buildings: Automated
1315 fault diagnosis of air handling units using generative adversarial networks, *Energies*. 12 (2019)
1316 1–11. <https://doi.org/10.3390/en12030527>.
- 1317 [43] T. Gao, B. Boguslawski, S. Marié, P. Béguery, S. Thebault, S. Lecoeuche, Data mining and
1318 data-driven modelling for air handling unit fault detection, *E3S Web Conf.* 111 (2019).
1319 <https://doi.org/10.1051/e3sconf/201911105009>.
- 1320 [44] G. Li, Y. Hu, H. Chen, H. Li, M. Hu, Y. Guo, J. Liu, S. Sun, M. Sun, Data partitioning and
1321 association mining for identifying VRF energy consumption patterns under various part loads
1322 and refrigerant charge conditions, *Appl. Energy*. 185 (2017) 846–861.
1323 <https://doi.org/10.1016/j.apenergy.2016.10.091>.
- 1324 [45] N.D. Pham, Q.L. Le, T.K. Dang, HOT aSAX: A novel adaptive symbolic representation for
1325 time series discords discovery, *Lect. Notes Comput. Sci. (Including Subser. Lect. Notes Artif.*
1326 *Intell. Lect. Notes Bioinformatics)*. 5990 LNAI (2010) 113–121. [https://doi.org/10.1007/978-](https://doi.org/10.1007/978-3-642-12145-6_12)
1327 [3-642-12145-6_12](https://doi.org/10.1007/978-3-642-12145-6_12).
- 1328 [46] J. Lin, E. Keogh, S. Lonardi, B. Chiu, A Symbolic Representation of Time Series with
1329 Implication for Streaming Algorithms-SAX.pdf, in: *DMKD '03 Proc. 8th ACM SIGMOD*
1330 *Work. Res. Issues Data Min. Knowl. Discov.*, 2003: pp. 2–11.
- 1331 [47] P.-N. Tan, M. Steinbach, V. Kumar, *Introduction to Data Mining*, Pearson, Boston, 2005.
- 1332 [48] R. Agrawal, R. Srikant, Mining Sequential patterns: Generalizations and performance
1333 improvements, in: Springer Verlag, 1996: pp. 3–15.
- 1334 [49] J. Pei, Mining sequential patterns efficiently by prefix-projected pattern growth, in: *Int. Conf.*
1335 *Data Eng. (ICDE2001)*, April, 2001.
- 1336 [50] J. Pei, J. Han, B. Mortazavi-Asl, J. Wang, H. Pinto, Q. Chen, U. Dayal, M.C. Hsu, Mining
1337 sequential patterns by pattern-growth: The prefixspan approach, *IEEE Trans. Knowl. Data*

- 1338 Eng. 16 (2004) 1424–1440. <https://doi.org/10.1109/TKDE.2004.77>.
- 1339 [51] M.J. Zaki, SPADE: An efficient algorithm for mining frequent sequences, *Mach. Learn.* 42
1340 (2001) 31–60. <https://doi.org/10.1023/A:1007652502315>.
- 1341 [52] J. Ayres, J. Flannick, J. Gehrke, T. Yiu, Sequential pattern mining using A bitmap
1342 representation, *Proc. ACM SIGKDD Int. Conf. Knowl. Discov. Data Min.* (2002) 429–435.
1343 <https://doi.org/10.1145/775107.775109>.
- 1344 [53] J. Pei, J. Han, W. Wang, Mining sequential patterns with constraints in large databases, *Int.*
1345 *Conf. Inf. Knowl. Manag. Proc.* (2002) 18–25. <https://doi.org/10.1145/584796.584799>.
- 1346 [54] Y.-L. Chen, T.-K. Huang, Discovering fuzzy time-interval sequential patterns in sequence
1347 databases, *IEEE Trans. Syst. Man, Cybern. Part B.* 35 (2005) 959–972.
- 1348 [55] Y. Hirate, Generalized Sequential Pattern Mining with Item Intervals, 1 (2006) 51–60.
- 1349 [56] Y.-L. Chen, M.-C. Chiang, M.-T. Ko, Discovering time-interval sequential patterns in
1350 sequence databases, *Expert Syst. Appl.* 25 (2003) 343–354.
1351 [https://doi.org/https://doi.org/10.1016/S0957-4174\(03\)00075-7](https://doi.org/https://doi.org/10.1016/S0957-4174(03)00075-7).
- 1352 [57] F.J. Martínez-De-Pisón, A. Sanz, E. Martínez-De-Pisón, E. Jiménez, D. Conti, Mining
1353 association rules from time series to explain failures in a hot-dip galvanizing steel line,
1354 *Comput. Ind. Eng.* 63 (2012) 22–36. <https://doi.org/10.1016/j.cie.2012.01.013>.
- 1355 [58] F.J. Martínez-de-Pisón Ascacibar, A. Pernía Espinoza, F. Martínez, Roberto, R. Escribano
1356 García, P. Guillén Rondón, D. Conti Guillén, System for uncovering hidden knowledge in real
1357 time for the analysis of environmental and agricultural processes, *XIII Int. Conf. Proj. Eng.*
1358 (2009).
- 1359 [59] G. Kaur, Association Rule Mining: A survey, *Int. J. Comput. Sci. Inf. Technol.* 5 (2014) 2320–
1360 2324.
- 1361 [60] T.M. Therneau, E.J. Atkinson, An introduction to recursive partitioning using the rpart
1362 routines, 1997.
- 1363 [61] A. Capozzoli, M.S. Piscitelli, S. Brandi, D. Grassi, G. Chicco, Automated load pattern learning

- 1364 and anomaly detection for enhancing energy management in smart buildings, *Energy*. 157
1365 (2018) 336–352. <https://doi.org/10.1016/j.energy.2018.05.127>.
- 1366 [62] R.K. Pearson, Data cleaning for dynamic modeling and control, *Eur. Control Conf. ECC 1999*
1367 - *Conf. Proc.* (2015) 2584–2589. <https://doi.org/10.23919/ecc.1999.7099714>.
- 1368 [63] S. Li, A Model-Based Fault Detection and Diagnostic Methodology for Secondary HVAC
1369 Systems, Drexel Univ. (2009).
- 1370 [64] M. Kim, S.H. Yoon, P.A. Domanski, W. Vance Payne, Design of a steady-state detector for
1371 fault detection and diagnosis of a residential air conditioner, *Int. J. Refrig.* 31 (2008) 790–799.
1372 <https://doi.org/10.1016/j.ijrefrig.2007.11.008>.
- 1373 [65] C.W. Roh, M. Kim, H.S. Kim, M.S. Kim, Design Method Of Steady State Detector For Multi-
1374 Evaporator Heat Pump System With Decomposition Analysis Technique, (2010).
- 1375 [66] C. Miller, Z. Nagy, A. Schlueter, A review of unsupervised statistical learning and visual
1376 analytics techniques applied to performance analysis of non-residential buildings, *Renew.*
1377 *Sustain. Energy Rev.* 81 (2018) 1365–1377. <https://doi.org/10.1016/j.rser.2017.05.124>.
- 1378 [67] A. Dexter, J. Pakanen, Demonstrating Automated Fault Detection and Diagnosis Methods in
1379 Real Buildings, in: *Proc. VTT Symp.* 217, 2001: p. 381. <https://doi.org/951-38-5725-5>.
- 1380 [68] M. Charrad, N. Ghazzali, V. Boiteau, A. Niknafs, NbClust: An R Package for Determining the
1381 Relevant Number of Clusters in a Data Set Malika, *J. Stat. Softw.* 61 (2014).
1382 <https://doi.org/10.18637/jss.v061.i06>.
- 1383 [69] R Core Team, R: A Language and Environment for Statistical Computing, (2017).
1384 <http://www.r-project.org/>.
- 1385 [70] M. Hahsler, B. Grun, K. Hornik, arules – A Computational Environment for Mining
1386 Association Rules and Frequent Item Sets, *J. Stat. Softw.* 14 (2005) 1–6.
1387 <papers2://publication/uuid/388D2132-AF39-463F-8D87-91A45FA1E26D>.
- 1388 [71] S. Ahmad, S. Purdy, Real-Time Anomaly Detection for Streaming Analytics, (2016).
1389 <http://arxiv.org/abs/1607.02480>.

1390

Appendix A

1391

Table A. Discretization intervals for all the analysed variables.

Variable	ID	Unit	Sym. A	Sym. B	Sym. C	Sym. D	Sym. E
SF_WAT	1	[W]	< 522 OFF	522 – 1265 ON	1265 – 2440 ON	> 2440 ON	-
RF_WAT	2	[W]	< 181 ON	181 - 337 ON	336 – 502 ON	> 502 ON	-
SA_CFM	3	[m ³ /h]	< 591 OFF	591 – 2276 ON	2276 – 3414 ON	3414 – 4706 ON	> 4706 ON
RA_CFM	4	[m ³ /h]	< 838 OFF	838 – 2712 ON	2712 – 3527 ON	> 3527 ON	-
OA_CFM	5	[m ³ /h]	< 477 ON	477 – 1146 ON	> 1146 ON	-	-
SA_TEMP	6	[°C]	< 15,9 ON	15,9 – 23,5 ON	23,5 – 32,4 ON	> 32,4 ON	-
MA_TEMP	7	[°C]	< 20,3 ON	20,3 – 30,8 ON	> 30,8 ON	-	-
RA_TEMP	8	[°C]	< 25,7 ON	25, 7 – 31,5 ON	>31,5 ON	-	-
HWC_DAT	9	[°C]	< 20,2 ON	20,2 – 26 ON	26 – 35,7 ON	> 35,7 ON	-
CHWC_DAT	10	[°C]	< 14,4 ON	14,4 – 22 ON	22 – 30,7 ON	> 30,7 ON	-
SF_DP	11	[Pa]	< 324 OFF	324 – 562 ON	562 – 770 ON	> 770 ON	-
RF_DP	12	[Pa]	< 46 ON	46 – 114 ON	> 114 ON	-	-
SF_SPD	13	[%]	< 50 OFF	50 – 67 ON	67 – 75 ON	75 – 87 ON	> 87 ON
RF_SPD	14	[%]	< 30 OFF	30 – 43 ON	43 – 57 ON	57- 69 ON	> 69 ON
OA_TEMP	15	[°C]	< 18,3 ON	> 18,3 ON	-	-	-
CHWC_EWT	16	[°C]	< 1,3 ON	1,3 – 2,8 ON	2,8 – 6,7 ON	> 6,7 OFF	-
CHWC_LWT	17	[°C]	< 13,3 ON	13,3 – 19,9 ON	19,9 – 21,2 ON	> 21,2 OFF	-
CHWC_GPM	18	[m ³ /h]	< 0,9 ON	0,9 – 1,7 ON	> 1,7 ON	-	-
E_ccoil	19	[kW]	< 11,7 ON	> 11,7 ON	-	-	-
CHWC_VLV	20	[%]	< 41 ON	41 – 75 ON	> 75 ON	-	-
EA_DMPR	21	[%]	< 20 ON	20 – 70 ON	> 70 ON	-	-
OA_DMPR	22	[%]	< 20 ON	20 – 47 ON	47 – 77 ON	> 77 ON	-
RF_SST	23	[-]	< 0,5 OFF	> 0.5 ON	-	-	-

1392

1393

Table A summarizes the transformation results obtained, with the specification of the numerical range

1394

corresponding to each symbol for all the analysed operational variables.

Table B. Most representative extracted temporal association rules.

ID N°	Antecedent	Consequent	Supp.	Conf.	ACTUAL TIME LAG	SUPP. DAY FAULTY
1077	SF_SPD [A-B], EA_DMPPR [A-B], RF_WAT [A-B]	CHWC_DAT [B-A]	0.70	0.8	15	0.27
1078	SF_WAT [A-B], EA_DMPPR [A-B], RF_WAT [A-B]	CHWC_DAT [B-A]	0.70	0.8	15	0.27
1526	SF_SPD [A-B], EA_DMPPR [A-B], RF_WAT [A-B]	CHWC_DAT [B-A], CHWC_LWT [B-A]	0.70	0.8	15	0.27
1527	SF_WAT [A-B], EA_DMPPR [A-B], RF_WAT [A-B]	CHWC_DAT [B-A], CHWC_LWT [B-A]	0.70	0.8	15	0.27
1864	SF_SPD [A-B], EA_DMPPR [A-B], RF_WAT [A-B]	CHWC_DAT [B-A], CHWC_LWT [B-A], SA_TEMP [B-A]	0.75	0.8	15	0.27
1865	SF_WAT [A-B], EA_DMPPR [A-B], RF_WAT [A-B]	CHWC_DAT [B-A], CHWC_LWT [B-A], SA_TEMP [B-A]	0.75	0.8	15	0.27
8661	RF_SPD [A-B], CHWC_LWT [C-B], EA_DMPPR [A-B]	CHWC_DAT [B-A], RF_SPD [B-C]	0.9	1	30	0.09
8750	RF_SPD [A-B], EA_DMPPR [A-B], RF_SST [A-B]	CHWC_DAT [B-A], RF_SPD [B-C]	0.8	0.89	30	0
6255	RF_SPD [A-B], CHWC_LWT [C-B], RA_CFM [A-B]	CHWC_DAT [B-A], RF_SPD [B-C], CHWC_LWT [B-A]	0.89	0.8	15	0.18
6256	RF_SPD [A-B], CHWC_LWT [C-B], RF_SST [A-B]	CHWC_DAT [B-A], RF_SPD [B-C], CHWC_LWT [B-A]	0.89	0.8	15	0.09
6226	RF_SPD [A-B], CHWC_LWT [C-B], RF_SST [A-B]	CHWC_DAT [B-A], RF_SPD [B-C], SA_TEMP [B-A]	0.89	0.8	15	0.09
6936	RF_SPD [A-B], CHWC_LWT [C-B]	CHWC_DAT [B-A], RF_SPD [B-C], SA_TEMP [B-A]	0.889	0.8	15	0.18
1933	SF_SPD [A-B], EA_DMPPR [A-B], RF_WAT [A-B]	CHWC_LWT [B-A], SA_TEMP [B-A]	0.75	0.8	15	0.27
1934	SF_WAT [A-B], EA_DMPPR [A-B], RF_WAT [A-B]	CHWC_LWT [B-A], SA_TEMP [B-A]	0.75	0.8	15	0.27
5257	RF_SPD [A-B], EA_DMPPR [A-B], RA_CFM [A-B]	RF_SPD [B-C]	0.82	1	30	0.18
5259	RF_SPD [A-B], EA_DMPPR [A-B], RF_SST [A-B]	RF_SPD [B-C]	0.82	1	30	0.09
6415	RF_SPD [A-B], CHWC_LWT [C-B], RF_WAT [A-B]	RF_SPD [B-C], CHWC_LWT [B-A]	0.8	0.8	15	0.09
6416	RF_SPD [A-B], CHWC_LWT [C-B], RF_DP [A-B]	RF_SPD [B-C], CHWC_LWT [B-A]	0.8	0.8	15	0.09
6126	RF_SPD [A-B], CHWC_LWT [C-B], RF_WAT [A-B]	RF_SPD [B-C], CHWC_LWT [B-A], SA_TEMP [B-A]	0.89	0.8	15	0.09
8309	RF_SPD [A-B], CHWC_LWT [C-B], EA_DMPPR [A-B]	RF_SPD [B-C], CHWC_LWT [B-A], SA_TEMP [B-A]	0.78	0.78	15	0.09
15268	RF_SPD [A-B], EA_DMPPR [A-B], RF_WAT [A-B]	RF_SPD [B-C], SA_TEMP [B-A]	0.8	0.89	30	0
15269	RF_SPD [A-B], EA_DMPPR [A-B], RF_DP [A-B]	RF_SPD [B-C], SA_TEMP [B-A]	0.8	0.89	30	0
1253	SF_SPD [A-B], EA_DMPPR [A-B], RF_WAT [A-B]	SA_TEMP [B-A]	0.70	0.8	15	0.27
1254	SF_WAT [A-B], EA_DMPPR [A-B], RF_WAT [A-B]	SA_TEMP [B-A]	0.70	0.8	15	0.27
1406	SF_WAT [A-B], EA_DMPPR [A-B], RF_WAT [A-B]	CHWC_DAT [B-A], SA_TEMP [B-A]	0.70	0.8	15	0.27
5240	CHWC_EWT [D-C], EA_DMPPR [A-B], RF_WAT [A-B]	CHWC_DAT [B-A], SA_TEMP [B-A]	0.70	0.8	30	0.27

1396

1397

1398

Table B reports 26 rules (two for each unique consequent transaction) extracted from the transient dataset with the specification of the event chains of antecedent and consequent, the value of support

1399 and confidence within the ACTUAL TIME LAG and its duration (evaluated on the training dataset),
1400 and the SUPP.DAY_{FAULTY} (evaluated on the testing dataset).