



POLITECNICO DI TORINO
Repository ISTITUZIONALE

Polarization reconfigurable patch antenna for compact and low cost UHF RFID reader

Original

Polarization reconfigurable patch antenna for compact and low cost UHF RFID reader / Tolin, Enrico; Vipiana, Francesca; Bruni, Simona; Bahr, Achim. - (2019), pp. 128-130. ((Intervento presentato al convegno 2019 IEEE International Conference on RFID Technology and Applications, RFID-TA 2019 tenutosi a ita nel 2019.

Availability:

This version is available at: 11583/2838263 since: 2020-07-06T11:38:46Z

Publisher:

Institute of Electrical and Electronics Engineers Inc.

Published

DOI:10.1109/RFID-TA.2019.8892109

Terms of use:

openAccess

This article is made available under terms and conditions as specified in the corresponding bibliographic description in the repository

Publisher copyright

ieee

copyright 20xx IEEE. Personal use of this material is permitted. Permission from IEEE must be obtained for all other uses, in any current or future media, including reprinting/republishing this material for advertising or promotional purposes, creating new collecting works, for resale or lists, or reuse of any copyrighted component of this work in other works.

(Article begins on next page)

Polarization Reconfigurable Patch Antenna for Compact and Low Cost UHF RFID Reader

Enrico Tolin
Dept. of Electronics and Telecom.
Politecnico di Torino
Torino, Italy
enrico.tolin@polito.it

Francesca Vipiana
Dept. of Electronics and Telecom.
Politecnico di Torino
Torino, Italy
francesca.vipiana@polito.it

Achim Bahr
Dept. of Antennas and EM modeling
IMST GmbH
Kamp-Lintfort, Germany
achim.bahr@imst.com

Simona Bruni
Dept. of Antennas and EM modeling
IMST GmbH
Kamp-Lintfort, Germany
simona.bruni@imst.com

Abstract— This paper presents a patch antenna designed for Ultra High Frequency (UHF) Radio Frequency Identification (RFID) reader including a reconfigurable feeding for achieving polarization agility. The switchable polarization improves the polarization efficiency in comparison with standard circular polarized antenna solutions. CMOS switches are used in the reconfigurable feeding network for enabling higher power transmission and uncomplicated control with respect to solutions involving varactors and PIN diodes. Moreover, the designed patch antenna and ground planes have reduced size, for best integration of the reader in the required application. The combination of antenna and reconfigurable feeding network has been tested through simulations, showing good performance over the EU RFID frequency band (865–868 MHz). Due to its flexible and inexpensive structure, the proposed reconfigurable feeding system is a promising alternative to standard circular polarized reader antenna approaches.

Keywords— UHF RFID, polarization agility, reconfigurable feeding network, RFID reader antenna

I. INTRODUCTION

In recent years, RFID technologies have gained great interests due their extensive use in many applications, such as transportation management system, access control, item identification and tracking [1]. The main components of an RFID system are the RFID reader, the reader antenna and the tag. The widespread use of this technology imposes the tag to be small and cheap, while the reader is the key element that determines the performance of the complete system. Typically, the reader should exhibit high gain, wide bandwidth, and a polarization suitable to match the reader orientation and to ensure a proper communication. In most cases, the reader has to deal with a random orientation of the tags, therefore circular polarization (CP) is used for ensuring a proper communication. Since the tag is usually linear polarized, CP yield to a loss of 3 dB.

Many researches have focused on innovative CP antenna designs [2]-[3], while others have exploited the reconfigurability concept in order to introduce the flexibility to choose between linear and circular polarization states [4]-[5]. However, by applying both solutions, still an inefficient condition for polarization may exist. In this work, we propose a reconfigurable feeding network that can select among four linear polarizations (i.e. horizontal, vertical, 45° and -45°).

It will be demonstrated that by this simple definition the maximum theoretical polarization loss will be less than 0.7 dB. Moreover, the constraint on antenna size plays an important role in real life application, due to the inclusion of the RFID system in many service structures and production facilities. This is especially critical in the frequency band under consideration, with respect to higher RFID frequency band (e.g. 2.45 GHz band). Different solutions were proposed in order to reduce the dimension of the RFID reader antennas, without affecting its performance [6]-[8]. In this work this important aspect is also addressed, and a method to reduce the size of the antenna is applied to the patch antenna.

II. DESIGN AND SIMULATIONS

A. Antenna Design

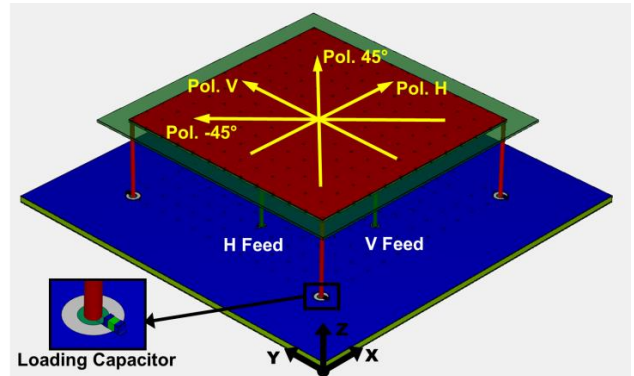

Fig. 1. 3D model of the proposed patch antenna. The detail of the aperture loading capacitor is reported on the bottom left side. The two feeding pins and the four polarization axes are also displayed.

As previously discussed, the goal of this work is to provide an advantageous solution for a RFID reader in terms of performance, integration capability and cost. For these reasons, a low cost suspended squared patch antenna realized in standard FR4 is considered as basis for the design. The height of the patch with respect to the ground plane is chosen to be 20 mm. Nevertheless, the typical half wavelength dimension of the patch antenna is too large to be integrated in most of applications where RFID is needed, and for this reason a size reduction technique is applied to the antenna.

This is obtained by loading the patch antenna with four fixed capacitors (all with same value $C_p = 0.4$ pF) connected with metal posts at the ground plane of the antenna, as is highlighted in Fig. 1. The loading capacitors increase the

equivalent electrical length of the patch antenna, and, in this way, its dimensions can be reduced to $0.175\lambda \times 0.175\lambda$ (with λ calculated at 868 MHz). The patch antenna is printed on a 0.5 mm thick PCB on both sides, which are then short circuited by a grid of vias for reducing resistive losses. Finally, four holes are drilled at the edges of the patch for inserting the metal posts, which are realized with 1 mm thick copper wire. Moreover, the same requirement of space miniaturization is requested to the antenna ground plane: therefore, the maximum side length of 95 mm x 95 mm is taken for the feeding board, realized on 1.55 mm thick FR4 substrate.

A pin feeding solution has been considered for this design, and two feeding points are positioned along the mid axes of the antenna, as depicted in Fig. 1.

B. Reconfigurable Feeding Network

As detailed in Sect II.A, in many applications size reduction is essential for best integration of the reader antenna. In this context, efficiency becomes a critical parameter and it directly affects the quality of RFID system (e.g. maximum distance for detecting an RFID tag). In this work, in order to overcome this 50% efficiency loss, polarization reconfigurability is applied at antenna feeding, with the goal of minimizing the polarization loss factor (PLF), defined as:

$$PLF = |\widehat{\rho}_r \cdot \widehat{\rho}_t|^2 = |\cos\varphi_p|^2 \quad (1)$$

where $\widehat{\rho}_r$ is the polarization unit vector of the reader antenna, and $\widehat{\rho}_t$ is the unit vector of the incoming wave impinging the antenna. The quantity φ_p represents the angle between the two unit vectors.

The solution proposed in this paper exploits a switchable feeding network for properly combining the two linear horizontal and vertical polarizations, excited by the two orthogonal feeds of the patch, respectively indicated as *Pin H* and *Pin V* in Fig. 2. In this way, not only the H and V polarizations can be used independently, but also the two diagonal polarizations 45° and -45° are added by mean of feeding the two input pins of the patch simultaneously and with proper phase. It is noticed that just by adding the diagonal polarizations a great reduction of the PLF with respect to the CP can be obtained, giving a theoretical maximum value of $PLF_{REC} = 0.69$ dB. This result is found by applying Eq. (1) and considering that the maximum of polarization mismatch is 22.5° (e.g. tag oriented exactly in the middle of H and 45° polarizations). As illustrated in Fig. 2, the four linear polarizations H, 45° , V and -45° are set by using CMOS switches for choosing the appropriate feeding line.

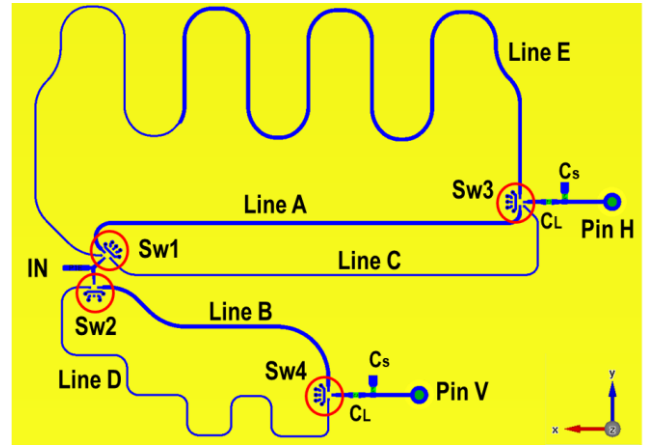

Fig. 2. Modeled reconfigurable feeding network, including the five feeding lines that are combined to give polarization agility. Components and main elements are named for clarity.

It is noticed that CMOS switches are easy to integrate in the feeding structure and they have superior performance in terms of maximum power handling with respect to PIN diodes and varactors, which cannot operate under the high power delivered by the UHF RFID front-end. Moreover, a four layer board design has been employed in order to place the DC supply and digital control lines in a dedicated layer. Therefore, the RF part of the designed antenna system is totally decoupled from the control lines of the switches.

The feeding network is then composed by a T-junction at input side (whose branches are kept as shorter as possible), that connects two switches used to select among the H and V feeding lines constructed with correct length and impedance: in particular two SP3T (Infineon BGSA13GN10) are used in the H feeding branch and two SP2T (Infineon BGSA12GN10) in the V feeding branch.

At patch antenna feeding points, an L-shaped matching network is used to match the antenna at the required RFID EU band. For proper matching the antenna with the feeding network, two high-Q capacitors are added in the simulated model, whose values are found to be $C_s=0.4$ pF and $C_L=1.7$ pF. For a reliable modelling of the reconfigurable feeding network, the equivalent electrical models of the switches have to be considered in both ON and OFF states: therefore, the ON series resistance and inductance as well as the OFF capacitance have been inserted at each RF port of the switches. In this way a more precise definition of the conductive losses and isolation have been modelled.

The four linear polarizations are obtained in the following way: H polarization is selected when *Sw1* and *Sw3* enable *Line A*, while *Sw2* and *Sw4* are set in the “all-OFF” state for disabling the connection with feeding lines in the V polarization branch. Conversely, V polarization is active by selecting *line B* through *Sw2* and *Sw4*, while the others are set to “all-OFF”. The 45° linear polarization is obtained by feeding both the H and V pins of the patch with the same phase, imposing the 50Ω condition at input terminal through an impedance transformer. Therefore, *line C* and *line D* are quarter wave transformers @ 868 MHz (characteristic impedance 70.7Ω). Finally, -45° polarization is achieved in a similar way as the case 45° , by selecting *line D* and *line E*, the latter being a line composed by a 90° transformer and a 180° delay line (total length of 270° at 868 MHz).

III. RESULTS AND DISCUSSION

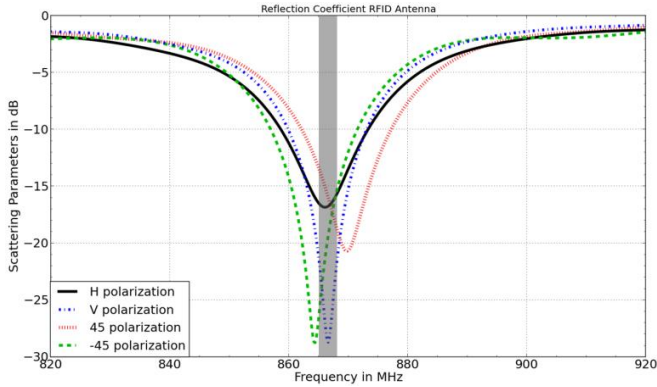

Fig. 3. Simulated reflection coefficients (EU band highlighted for reference) for the four operative polarization states, corresponding to different linestyles and colors.

The simulated reflection coefficient for the complete reconfigurable patch in the four considered polarization states is presented in Fig. 3. It is recognized that the EU band is well matched in all four cases (worst value found at 865 MHz in the 45° polarization case, with $|S_{11}|$ is -13.7 dB), even if a variability of the antenna matching is observed in all the four states. This is explained by considering the loading effect of the disabled lines caused by the finite isolation of the switches.

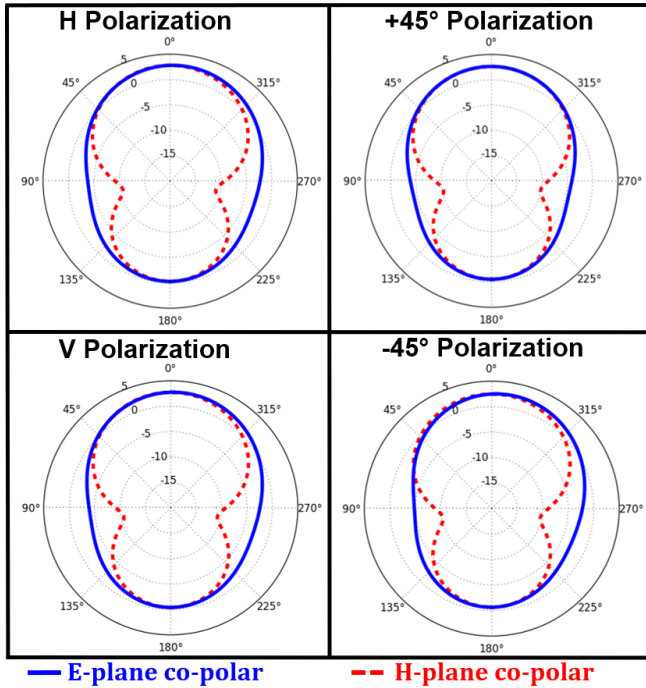

Fig. 4. Simulated antenna gain at 868 MHz in the four polarization states.

Antenna gain has also been evaluated in the four polarizations. In Fig. 4 the resulted antenna gains are reported for 868 MHz, where the measured planes are consistent with the specified polarization. In particular, the gain is maximum for the V polarization with a value of 2.9 dB, while it is minimum at 45° polarization, where a gain of 2.6 dB is measured. It is noticed that the gain of the patch antenna is limited by the electrically small ground plane.

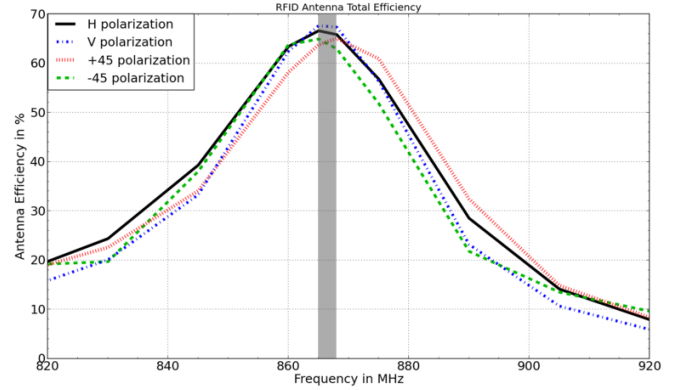

Fig. 5. Simulated total efficiency for the four polarization states (EU band highlighted for reference).

The difference between gain levels is given by the different path loss, which is dependent on the specific feeding condition selected (i.e. number of transitions through switches and length of the feeding lines). Moreover, the particular switching state is also an important factor, since the used switches exhibit different insertion losses depending on the enabled path, from a minimum of 0.16 dB to a maximum of 0.36 dB at 900 MHz, according to datasheet.

Finally, the simulated total efficiency is reported in Fig. 4, where a range from 63% to 68% is found in RFID EU band. It is reminded here that the total efficiency takes into account for all the losses in the antenna and in feeding network, and also in this case the reported value for the reduced size RFID antenna is better than 50%, which is the theoretical limit of an ideal CP antenna when excited from a linear polarized wave.

IV. CONCLUSION AND PERSPECTIVES

In this paper, the design of a polarization reconfigurable UHF RFID antenna system operating in the EU frequency band has been presented. The introduced polarization agility performs a more efficient polarization matching with respect to standard CP approaches, in the typical RFID scenario where many tags with random orientation have to be interrogated by the RFID reader antenna. Moreover, for improving the integration of the antenna in the reader, loading capacitors have been used for reducing its overall size. The switching feeding network is a flexible and cost effective solution for narrowband RFID reader applications for improving the overall efficiency. As further perspective, a more compact solution for the reconfigurable feeding network will be developed. Moreover, a more symmetric feeding structure will be investigated, in order to reduce the variability of the gain among the four polarization states. Finally, a prototype will be manufactured and measured, for validation of the proposed concept.

REFERENCES

- [1] Finkenzeller, K., *RFID Handbook: Fundamentals and Applications in Contactless Smart Cards, Radio Frequency Identification and Near-Field Communication*, John Wiley & Sons, 2010
- [2] J. Guo, J. Ouyang, Y. Yan, S. Zhang and Z. Lu, "Compact Circular Polarization Antenna Based on Slot Structure for UHF RFID Handheld Reader," *2018 IEEE International Symposium on Antennas and Propagation & USNC/URSI National Radio Science Meeting*, Boston, MA, 2018, pp. 331-332.
- [3] P. Janpangern and C. Phongcharoenpanich, "Circularly polarized single-fed wide-slot antenna for UHF RFID reader," *2017*

International Symposium on Antennas and Propagation (ISAP), Phuket, 2017, pp. 1-2.

- [4] D. Duraj, K. Nyka and M. Rzymowski, "Dual polarization antennas for UHF RFID readers," *2014 20th International Conference on Microwaves, Radar and Wireless Communications (MIKON)*, Gdansk, 2014, pp. 1-4.
- [5] P. Parthiban, B. Seet and X. J. Li, "Low-cost low-profile UHF RFID reader antenna with reconfigurable beams and polarizations," *2017 IEEE International Conference on RFID (RFID)*, Phoenix, AZ, 2017, pp. 81-87.
- [6] T. Wu, H. Su, L. Gan, H. Chen, J. Huang and H. Zhang, "A Compact and Broadband Microstrip Stacked Patch Antenna With Circular Polarization for 2.45-GHz Mobile RFID Reader," in *IEEE Antennas and Wireless Propagation Letters*, vol. 12, pp. 623-626, 2013.
- [7] R. Colella, L. Catarinucci, A. Michel and P. Nepa, "Design of a 3D-printed circularly polarized antenna for portable UHF RFID readers," *2017 IEEE International Conference on RFID Technology & Application (RFID-TA)*, Warsaw, 2017, pp. 225-228.
- [8] R. Cao and S. Yu, "Wideband Compact CPW-Fed Circularly Polarized Antenna for Universal UHF RFID Reader," in *IEEE Transactions on Antennas and Propagation*, vol. 63, no. 9, pp. 4148-4151, Sept. 2015.