

Thermophilic vs. mesophilic anaerobic digestion of waste activated sludge: Modelling and energy balance for its applicability at a full scale WWTP

Original

Thermophilic vs. mesophilic anaerobic digestion of waste activated sludge: Modelling and energy balance for its applicability at a full scale WWTP / Ruffino, B.; Cerutti, A.; Campo, G.; Scibilia, G.; Lorenzi, E.; Zanetti, M.. - In: RENEWABLE ENERGY. - ISSN 0960-1481. - STAMPA. - 156:(2020), pp. 235-248. [10.1016/j.renene.2020.04.068]

Availability:

This version is available at: 11583/2837601 since: 2020-06-29T16:02:19Z

Publisher:

Elsevier Ltd

Published

DOI:10.1016/j.renene.2020.04.068

Terms of use:

This article is made available under terms and conditions as specified in the corresponding bibliographic description in the repository

Publisher copyright

(Article begins on next page)

Thermophilic vs. mesophilic anaerobic digestion of waste activated sludge: modelling and energy balance for its applicability at a full scale WWTP

Barbara Ruffino¹ (*), Alberto Cerutti¹, Giuseppe Campo¹, Gerardo Scibilia², Eugenio Lorenzi²,
Mariachiara Zanetti¹

¹Department of Environment, Land and Infrastructure Engineering, Politecnico di Torino, corso Duca degli Abruzzi, 24 - 10129 Torino, Italy

²Research Center, Società Metropolitana Acque Torino S.p.A., Viale Maestri del Lavoro, 4 – 10127 Torino, Italy

(*). Corresponding author

Barbara RUFFINO

DIATI, Department of Environment, Land and Infrastructure Engineering

Politecnico di Torino

Corso Duca degli Abruzzi, 24

10129 Torino, ITALY

Ph. +39.011.0907663

Fax +39.011.0907699

e-mail: barbara.ruffino@polito.it

Highlights

- A comparison between mesophilic and thermophilic digestion was carried out
- A first-order rate reaction was used to model experimental data, B_0 and k were obtained
- The model was calibrated on one scale (44 L) and validated on a larger scale (240 L)
- A thermophilic process can successfully substitute a pre-treatment of mechanical nature
- Heat exchange practices allow to work with low TS content and save natural gas

Abstract

Sewage sludge produced in WWTPs are currently digested in mesophilic anaerobic digestion (AD) processes with the aim of recovering heat and electricity. However, often, the low biodegradability of waste activated sludge (WAS) limits the complete thermal self-sustainability of the process. This study presents the results of AD tests carried out on WAS in semi-continuous reactors (44 L and 240 L) in mesophilic (38 °C) and thermophilic (55 °C) thermal regimes. The hydraulic retention time (HRT) was 20 days and the organic loading rate (OLR) of 1 kg VS/m³·d in all tests. The tests returned a specific methane production (SMP) of 0.120 Nm³/kg VS added for the mesophilic process (240 L reactor) and SMPs of 0.188 and 0.176 Nm³/kg VS added for the tests carried out under the thermophilic regime in 44 L and 240 L, respectively. Experimental data were modelled with a first-order rate reaction, where B₀, that is the SMP after an infinite HRT, and k, the hydrolysis constant, were the key parameters. B₀ and k were found equal to 0.147 Nm³/kg VS and 0.08 d⁻¹ respectively, for the mesophilic process, and to 0.218 Nm³/kg VS and 0.350 d⁻¹ for the thermophilic process. For the thermophilic process, the model was calibrated with the data from the 44 L reactor and validated with those from the 240 L reactor. An error of only 1% resulted. Finally, it was demonstrated that a full-scale digestion scheme, where primary and secondary sludge were digested separately, in mesophilic and thermophilic conditions respectively, and the heat of the digestates was used to heat the cold sludge, allowed to carry out the process with a complete thermal self-sustainability already at a sludge TS content of 3%.

Keywords

Degradation extent; heat exchange; hydrolysis rate; secondary sludge; specific methane production

1. Introduction

In the view of a transition from the traditional concept of wastewater treatment plant (WWTP) to a water resource recovery facility (WRRF), anaerobic digestion (AD) of sewage sludge generated in the WWTP plays a crucial role. In fact, AD is a technology that offers several advantages, including the stabilization of biodegradable fractions, the reduction of greenhouse gas emissions associated with sludge landfilling, and the production of renewable energy in the form of heat and electricity. Finally, digested sludge can become a valuable agricultural soil conditioner and a source of slow-release nutrients and microelements [1, 2].

However, the low biodegradability of waste activated sludge (WAS) is a strong limitation to the conversion of volatile solids (VSs) to methane [3]. In fact, most of the biodegradable substrate is either enclosed inside the microbial cell wall or enmeshed in an extracellular polymeric matrix [4, 5]. Pre-treatments of several types (mechanical, thermal, chemical or a combination of them) are recognized to be useful to overcome this limitation [6]. Also increases in the temperature of the digestion process, shifting the thermal regime from mesophilic to thermophilic conditions, have been demonstrated to be capable of enhancing metabolism kinetics and the degradation rates of sewage sludge [7]. That means that more biogas could be obtained faster. Thermophilic digestion can therefore be a good choice for reducing VSs and deactivating pathogens in the treatment of WAS and organic waste [8]. However, the high rate of hydrolysis and acidification, that leads to the accumulation of VFAs, can inhibit the activity of methanogens and potentially decreases the biogas production. Thermophilic conditions enhance growth of hydrolytic and fermentative bacteria that have faster metabolic rates than methanogenic archaea. As a result, their metabolic byproducts, such as VFA and CO₂, are produced at higher rates than acetic acid, which is the main precursor for methane production [9]. The supplement of microelements (for example, Ca, Fe, Ni, and Co) can be of help to ensure the effective removal of VFAs, and specifically of propionate, in a thermophilic digester [10-12]. Another solution to prevent the inhibition from VFA

accumulation can be the combination of a thermophilic reactor with a traditional mesophilic reactor in a two-stage system. The first thermophilic (or hyper-thermophilic), low HRT stage is used to solubilized the substrates aiming at a more efficient and non-inhibited methane generation in the second reactor [13, 14]. This configuration is of particular interest especially for substrates with low biodegradability, such as WAS, fat, oil and grease [15, 16] or agricultural/food waste products containing relevant amount of cellulose [17].

Other limitations of thermophilic AD processes have been identified in low stability, susceptibility to the environmental conditions, accumulation of ammonia (NH_3) that, together with VFAs, especially at high feeding rate [18], potentially leads to the formation of intermediate, nitrogen-containing, refractory compounds (such as pyrazines, [19]) and quality of the final effluent. From an energy point of view, a thermophilic AD process requires more heat to sustain the process compared to mesophilic conditions. Although the major part of the heating requirements consists of sludge heating, accounting twice those of mesophilic digestion, the increased biogas production can provide the surplus energy needed [20, 21]. Recently, to overcome this problem, Zhang and coauthors [22] suggested to equip the thermophilic anaerobic reactor with a solar pond, so as to provide the energy necessary to maintain the digester temperature.

The substitution of a traditional mesophilic process for WAS digestion with a thermophilic one in the sludge line of a full scale WWTP requires careful considerations regarding, on the one hand, the kinetics and long-term stability of the process and, on the other hand, its thermal self-sustainability. Results obtained from digestion tests at a lab or pilot scale can be profitably used for upscaling the process only if physical, chemical and biochemical phenomena which take place in the AD process are well understood. With this aim, over the past years, several models have been developed. One of the most complete model is IWA Anaerobic Digestion Model n.1, shortly ADM1, developed by the IWA research group at the beginning of the 2000's [23]. This model includes a series of physical – chemical and

biochemical dynamic state variables and requires a huge analytical effort to collect all the parameters necessary to the implementation in its complete form. However, for design purposes, that is the estimation of digester volume, biogas production, degradation rate or feed flow rate, simpler models can be very useful [8]. Specifically, if hydrolysis is assumed to be the limiting step of the whole AD process, and in the absence of an initial lag phase, the methane production in a reactor with a given HRT can be described with a very simple first order kinetic model as in Equation (1)

$$B(t) = B_0 (1 - e^{-kt}) \quad (1)$$

where B_0 is the specific methane production after an infinite HRT (that is the theoretical amount of methane produced by the whole biodegradable VS in the substrate) and k is the hydrolysis constant [24, 25]. The kinetic parameters were determined based on the methane production of the semi-continuous reactor, which is more reliable than the BMP tests for this purpose. Data obtained from the tests allowed the determination of the optimal sets of the two parameter values by using best fit algorithms.

This study compares the results of two thermophilic digestion tests carried out on WAS in two semi-continuous reactors with different volumes (44 and 240 liters) with those of a mesophilic test (240 L) on the same substrate. Experimental data of methane production and residual VS after digestion were both used to obtain the key parameters of the first-order kinetic rate reaction model, that is B_0 , and k . These results were used to evaluate how the substitution of the present mesophilic digestion process of WAS with a thermophilic one can affect the energy performances of the sludge line of a full scale (2 million equivalent inhabitants) WWTP.

2. Materials and Methods

2.1 Reactor set up and operations

This study presents three tests, all involved the WAS samples described in Section 2.2. One test was carried out in a CSTR digester with a working volume of 240 liters operating in mesophilic (38 °C) conditions (HRT = 20 days). The other two tests were carried out in two CSTRs with working volumes of 44 and 240 liters respectively. Both reactors have operated in thermophilic conditions (55 °C) with a HRT of 20 days.

The two reactors were made of a stainless steel tank where the heat was provided through a coil wrapped around each tank. The mixing inside the two reactors was guaranteed through biogas recirculation for 15 min every hour. The two reactors were equipped with gasometers and systems for on-line monitoring of biogas volume and composition.

Fresh substrate was fed five times per week, from Monday to Friday, and digestate was extracted with the same frequency. In all the tests the organic loading rate (OLR) was in the order of 1-1.1 g VS/L·d. The biogas production and composition (CH₄, CO₂, O₂, others) were recorded every working day, from Monday to Friday for the whole duration of the test. The volume of methane was determined by multiplying the volume of biogas by the percentage of methane in the biogas and calculated at normal pressure and temperature conditions (273.15 K and 101.325 kPa). The biogas composition in terms of CH₄, CO₂, O₂ was obtained by flushing 500 mL of the collected biogas through a biogas analyzer (Biogas Check, Geotechnical Instruments Ltd).

2.2 Substrate and inoculum

For this study samples of WAS were weekly collected from the outlet of the two gravity pre-thickeners used in the WWTP located in Castiglione Torinese (20 km from Turin, NW Italy). The Castiglione Torinese plant is one of the WWTPs managed by SMAT (Società Metropolitana Acque Torino), the

company that manages the integrated water service in the Metropolitan City of Turin. Details of the water and sludge line of the WWTP were provided in a previous paper [26]. The WWTP has a standard configuration including the following treatment phases: preliminary treatments (grating and sand/oil removal), primary settling, pre-denitrification, biological oxidation with a sludge retention time (SRT) of ca. 25 days, secondary settling and final filtration on a gravel and anthracite bed.

The WWTP has a treatment load of approximately 2,000,000 population equivalent (p.e.) and generates 4320 kg TS/h of sludge (before AD). Primary sludge represents 64% by weight (b.w.), on a TS basis, of the overall sludge amount produced in the wastewater treatment lines. The mass flow rate of WAS is 1555 kg TS/h, with an average total solid (TS) content of 0.8%. Pre-thickeners located in the sludge line of the WWTP increase the TS content of the WAS from 0.8% to approximately 2–3%.

Inoculum was collected from the ACEA plant, a facility located in the Turin surroundings where the organic fraction of municipal solid waste is treated by using a thermophilic digestion process. The use of a thermophilic digestate to inoculate thermophilic reactors was justified because thermophilic digestate provides a faster start-up to thermophilic reactors, along with a more stable operation since it avoids a rapid temperature change from mesophilic to thermophilic regime that may bring about a population shift if the groups are not compatible, especially a decrease in thermophilic methanogens, crucial to digestion stability [27].

2.3 Analytical methods

Total and volatile solids were determined according to Standard Methods [28]. The VFA/TA (FOS/TAC, in the German technical literature) parameter is the ratio between VFA, which stands for volatile fatty acids, expressed in equivalent milligrams of acetic acid per liter, and TA, which stands for Total Alkalinity, expressed in mg equivalent of calcium carbonate per liter. The VFA/TA ratio is an easy-to-do and reliable measure of the risk of acidification of a biogas plant. It was obtained by a potentiometric

titration, according to the Nordmann method [29], by using a SI Analytics automatic titrator. Specifically, a sample of 20 mL of fermentation substrate is titrated by 0.1 N of sulfuric acid solution (H_2SO_4) up to pH 5.0 to calculate the TA value, expressed in mg/L of calcium carbonate (CaCO_3). Then the VFA value is obtained after a second titration step between pH 5.0 and pH 4.4. It is expressed in mg/L of acetic acid (CH_3COOH).

2.4 Modeling

The phases of development, calibration and validation of a model are useful to predict the performances of a digester when boundary conditions are made to change. Boundary conditions are, for example, the HRT or the number of stages through which the process is carried out. A model is also a supporting tool when data obtained from a lab or pilot scale test must be scaled up to a full scale plant, for the estimation of digester volume, biogas production, degradation rate or feed flow rate.

Batch (BMP tests) and semi-continuous digestion tests are commonly employed to assess the methane production of a substrate. However, the results of those tests depend on several parameters, namely: the activity and origin of the inoculum, temperature, digestion time, ratio between inoculum substrate and hydrolysis coefficient. Consequently, to make possible the comparison between two substrates or two digestion modes in terms of methane production, it is necessary to identify some parameters capable to fully and uniquely describe the digestion process [24, 30].

In AD processes of particulate/complex substrates, such as WAS, where the disintegration-hydrolysis phase can be assumed as the rate-limiting step of the overall process [31], the evolution of the methane production from an AD process, $B(t)$, can be modelled according to a first-order reaction rate, as in Equation 1, here recalled.

$$B(t) = B_0 (1 - e^{-kt}) \quad (1)$$

In Equation 1 $B(t)$ is the evolution of the methane production in time, B_0 is the biochemical methane potential, that is the maximum amount of methane that a substrate can produce after an infinite time of AD, and k is the hydrolysis rate constant, that is a first order kinetic constant able to model the disintegration process. In this case, B_0 and k are capable of completely describing the AD process.

In this work the parameters B_0 and k for a WAS substrate digested under thermophilic conditions (55 °C) were obtained from the fitting of the experimental data that resulted from the test carried out in the 44 L digester. Subsequently, the reliability of the above mentioned parameters was verified by using the data obtained from the test carried out in the 240 L digester with the same substrate.

Equations 2 and 3 describe the evolution of the biodegradable VS (VS_b) and the specific methane production (B_d) during a digestion process, respectively.

$$\frac{dVS_b(t)}{dt} = \frac{q(t) \cdot VS_{b,in}(t)}{V} - \frac{q(t) \cdot VS_b}{V} - k \cdot VS_b(t)$$

(2)

$$B_d(t) = VS_b(t) \cdot k \cdot B_0 \cdot V$$

(3)

Specifically, Equation 2 describes the mass balance of biodegradable VS (VS_b) as a sum of input of fresh substrate, output of the digested product and degradation term. In Equation 2, V is the volume of the digester, $q(t)$ is substrate flow rate, $VS_{b,in}$ and VS_b are the amount of biodegradable VSs in the fresh substrate and in the digested product, respectively. Equation 3 puts in relation the daily methane production, at time t , $B_d(t)$, with the amount of VS_b at the same time frame, the hydrolysis rate (k), the biochemical methane potential (B_0) and the volume of the reactor (V). Equations 2 and 3 contain the two parameters (B_0 , k) that are determined with the calibration phase.

Even if the two Equations 2, 3 contain two variables on the whole, the optimal set of B_0 and k values was obtained by minimizing the objective function (J), that is the residual sum of squares (RSS) between the measured data and model predicted data, as defined in Batstone and coauthors [32]. If the residuals are normally distributed, a critical value (J_{crit}) that defines the surface of the parameter uncertainty region can be defined using the F distribution, as in Equation 4 [32, 33].

$$J_{crit} = J_{min} \left(1 + \frac{p}{N_{data} - p} \cdot F_{\alpha, p, N_{data} - p} \right)$$

(4)

where J_{crit} is the critical value, N_{data} is the number of measured data points, p is the number of parameters, and $F_{\alpha, p, N_{data} - p}$ is the value of the F distribution for α , p , and $N_{data} - p$. A value of $\alpha = 0.05$ was used to estimate the 95% confidence regions.

It is important to keep in mind that one part of the solids fed to the digester are of volatile nature and the other part is made of fixed solids. The elemental composition of the VS can be assessed through an elemental analysis (C, H, N, O) and, starting from this composition, the theoretical methane production of the substrate, B_{th} , can be calculated by referring to the Buswell and Neave formula, as in Equation 5

$$B_{th} = VS_{in} \cdot \frac{COD_{in}}{VS_{in}} \cdot 0.350 \frac{Nm^3 CH_4}{kg COD}$$

(5)

B_{th} is the amount of methane that would be produced if all the VSs were biodegradable and the digestion process was fully completed (i.e. had an infinite length). However, not all the VSs of real substrates are biodegradable. Only biodegradable solids contribute to the biogas / methane production. For this reason, the maximum methane production, B_0 , of a given substrate can be defined. B_0 is the specific amount of methane (Nm^3/kg VS) that can be extracted from an organic substrate after a digestion of infinite length in time and, because of the presence of the non-biodegradable VS (VS_{nb}), it is smaller than B_{th} . In a real

case, the SMP is smaller than B_0 , because, as in Equation 6, the hydrolysis process (the rate of which is quantified by the kinetic constant, k) and the actual duration of the digestion (HRT) limit the methane production.

$$B_d(t) = \left(1 - \frac{1}{1 + k \cdot HRT}\right) B_0$$

(6)

The parameter Y is the absolute biodegradation (or degradation extent), an intrinsic characteristic of the substrate, and it is the ratio between B_0 and B_{th} . Because of the relation between B_0 and VS_b , and B_{th} and VS , Y can also be defined as the ratio between the biodegradable VS , VS_b , and the total VS .

$$Y = \frac{B_0}{B_{th}} = \frac{VS_b}{VS_{tot}}$$

(7)

$$B_d(t) = VS_b(t) \cdot k \cdot B_0 \cdot V$$

(8)

The daily production of methane, $B_d(t)$, as reported in Equation (1) can be modified with the introduction of the degradation extent (or absolute biodegradability, Y). In order to predict the daily VS_b concentration $VS_b(t)$ in the digestate, as well as the daily methane production, Equations 2 and Equation 3 must be modified with the introduction of the degradation extent (or absolute biodegradability, Y) as following:

$$\frac{dVS_b(t)}{dt} = \frac{q(t) \cdot Y \cdot VS_{tot,in}(t)}{V} - \frac{q(t) \cdot VS_b}{V} - k \cdot VS_b(t)$$

(9)

$$\frac{dVS_{nb}(t)}{dt} = \frac{q(t) \cdot (1 - Y) \cdot VS_{tot,in}(t)}{V} - \frac{q(t) \cdot VS_{nb}}{V}$$

(10)

$$VS(t) = VS_b(t) + VS_{nb}(t)$$

(11)

$$B_d(t) = VS(t) \cdot k \cdot Y \cdot B_{th} \cdot V$$

(12)

3. Results and Discussion

3.1 Mesophilic digestion

The digestion test of WAS carried out in mesophilic condition (38 °C) in the 240 L digester lasted approximately four months. This test was part of another experimentation that involved the verification of the efficiency of pre-treatments at a pilot scale. The results of this test are briefly reported in this paper only for sake of comparison with the results obtained in the tests carried out in thermophilic conditions (55 °C) (see Sections 3.2 and 3.3). The WAS samples used for the test had an average TS and VS content of 3.05% and 2.04% respectively.

As it can be seen from Figure 1, after a start-up phase, the daily methane production settled on values in the order of 0.020 – 0.025 Nm³/d. Because the digester was continuously fed with a sludge with a VS content in the order of 2%, a SMP of approximately 0.120 Nm³/kg VS fed resulted upon reaching the steady state. This result was in good agreement with the findings from other studies: for example, Coelho and coauthors [27] obtained a SMP of 0.101 Nm³/kg VS in a continuous reactor, with HRT = 20 days, digesting WAS samples collected in a conventional activated sludge plant with a SRT of 5 days.

Figure 1. Daily methane production (dots) and results of the modelling (solid curve) for a WAS digested in mesophilic conditions (38 °C) in the 240 L reactor (HRT = 20 days)

However, it can be seen from Figure 1 that the daily production of biogas and methane was heavily affected by the frequency of digester feeding. In fact, the digester was fed only five days per week and the feeding was in any case suspended in the case of days off. For this reason, it was not possible to keep the HRT at a constant value. Consequently, it was verified if, with the aid of a model, the raw data collected from the experimentation could be used to provide a complete description, in term of maximum methane production and hydrolysis rate constant, of the AD process, because the raw data alone were not sufficient to quantify the substrate production at a fixed HRT (equal to 20 days, in the case of this experimentation). Moreover, with the only raw outcome of the test it was not possible to predict the substrate production at different HRT values or in situations where more than one reactor was used for the digestion process (for example two reactors working with HRT = 10 days each). A well calibrated and validated model can overcome this limitation. The model presented in Section 2.4 was used to fit the data coming from the experimentation carried out in mesophilic conditions. One of the aims of this study was indeed to demonstrate that the model, reported in Eq. 1 and currently employed to interpret experimental data from batch tests (BMP tests), could be successfully used to predict the evolution of an AD process carried out in a semi-continuous mode and under non-steady state conditions. If the two following conditions apply, that is that hydrolysis is the limiting phase of the whole AD process and the substrate's biodegradability is constant in time, the model allows to estimate B_0 and k parameters even from data obtained from semi-continuous, non-stationary tests.

It is well known that for particulate substrates, hydrolysis is inevitably the first phase of the AD process. Hydrolysis is the only phase of the whole AD process not directly mediated by the activity of the trophic chain of the microorganisms involved in the biochemical transformation process of the substrate into

biogas. Hydrolysis is a superficial phenomenon that transforms the particulate substrate into small molecules that can cross the cell walls of microorganisms. This phenomenon has traditionally been modeled according to a first order kinetics, as in Eq. 1, and it is not a function of the concentration of microorganisms present into the digester [23, 32, 34-35].

The minimization of the objective function, J, presented in Section 2.4, returned B_0 and k values equal to $0.147 \text{ Nm}^3/\text{kg VS}$ and 0.08 d^{-1} respectively. It can be seen from Figure 2 that the single points representing the cumulative methane production recorded during the test were very well fitted by the model.

Figure 2. Cumulative methane production (dots) and results of the modelling (solid curve) for a WAS digested in mesophilic ($38 \text{ }^\circ\text{C}$) conditions in the 240 L reactor (HRT = 20 days)

Furthermore, Figure 1 shows that the model was able to adequately predict not only the phase of the process at steady-state, but also the start-up phase of the digester and the daily fluctuations. The values of the two model parameters B_0 and k were in good agreement with the figures found by Wei and coauthors [33] from BMP batch tests. They modelled their data with the same model used in this work and obtained values of B_0 and k of $0.160 \text{ Nm}^3/\text{kg VS}$ and 0.22 d^{-1} , respectively, for a secondary sludge with a SRT of 15 days.

3.2 Thermophilic digestion in the 44 L reactor (phase 1): model calibration

The 44 L digester was fed 29 times, for a period of approximately two months (57 days), with a WAS with average TS and VS content of 3.2% and 2.2% respectively. The ratio between VS and TS in the sludge samples decreased from 69.7% to 65.4% from the beginning to the end of the test, because of the increase of the air and water temperatures, from the spring to the summer season, in the activated sludge basins of the water line. This temperature increase accelerated the rates of the biological reactions into the activated sludge basin and, consequently, decreased the VS content of the secondary sludge.

Figure 3 shows the evolution of the SMP from the 44 L reactor. It can be seen that, after a non-stationary phase approximately 25 days long, the average SMP was of $0.188 \pm 0.01 \text{ Nm}^3/\text{kg VS fed}$. This value was 57% higher than that obtained in mesophilic conditions in the 240 L reactor. The VS reduction was of 36%. These results show that, in the case of WAS, the temperature of the reactor positively affected the digestion of WAS. Conversely, the methane production of some other substrates (i.e. microalgae) seemed to be negatively affected by the temperature increase [7]. However, the same authors, observed an increment in the biogas production of 25.5%, on a sample of WAS, moving from mesophilic to thermophilic conditions [7].

Figure 3. Evolution of the SMP from the 44 L and 240 L reactors, thermophilic conditions (55 °C), HRT = 20 days

In the most recent years several authors carried out semi-continuous tests in thermophilic conditions on WAS using different HRTs. For example, Leite and coauthors [2] obtained a SMP of $0.130 \text{ Nm}^3/\text{kg VS fed}$ and a VS reduction of 34% in a single-stage digester working with a HRT of 20 days, an OLR of $2.2 \text{ kg VS}/\text{m}^3 \cdot \text{d}$ and WAS samples with a SRT of 15 days. In a subsequent test with a different WAS, Leite and coauthors [9] obtained a higher SMP ($0.154 \text{ Nm}^3/\text{kg VS fed}$ with a HRT = 13 d, OLR = $1.3 \text{ kg VS}/$

m³·d). Braguglia and coauthors [36] obtained a very similar value, 0.160 Nm³/kg, working with a HRT = 15 d and an OLR of 1.0 kg VS/ m³·d. The SMP obtained in the present test was considerably higher than those reported in the above mentioned studies.

Notwithstanding the thermophilic regime, the system maintained a good stability for all the duration of the test. Li and coauthors [37] observed that a low feeding frequency, like that applied in this study, with the two days break due to the week-end, could cause a heavy loading shock during the short feeding period, leading to fast acidification, especially under thermophilic conditions. Growth of hydrolytic and fermentative bacteria is enhanced under thermophilic conditions and they generate faster metabolic rates than methanogenic archaea. As a result, their metabolic byproducts, such as VFA and CO₂, could be produced at higher rates than acetic acid, which is the main precursor for methane production, thus making the system unstable [9]. This drawback was not observed in this test, in fact the pH value of the digestate and, consequently, of the digester content assuming this perfectly mixed, was at an approximately constant value of 7.74 ± 0.11 . The VFA parameter increased, from the beginning to the end of the test, from approximately 360 to 580 mg equivalent CH₃COOH/l, but it was however well balanced by a corresponding increase in the TA parameter, from approximately 3000 to 3700 mg equivalent CaCO₃/l, that kept the VFA/TA ratio to values in the range 0.13-0.15 (data not shown). The substrate fed to the digester was not conditioned with any buffering substance.

The evolution of the residual VS into the digestate for all the duration of the test is shown in Figure 4.

Figure 4. Evolution of the residual VS into the digestate, 44 L reactor, thermophilic conditions, HRT = 20 days, experimental data (dots) and model (solid curve)

The residual VS was the sum of the non-biodegradable VS and the biodegradable VS that were not consumed during the digestion. It could be seen that the concentration of the residual VS into the digester

increased from 9 kg VS/m³, at the beginning of the test, to approximately 12 kg VS/m³ at the end of the test. Even if the test had reached a stable condition for what concerns the methane production, the continuous increase in the residual TS into the digestate could be attributed to the non-constant characteristics of the fed sludge. In fact, the concentration of VS into the WAS fed to the reactor increased from 9 kg VS/m³ at the beginning of the test to values of 18 kg VS/m³ at the end of the test (data not shown). As pointed out in Section 3.1, the model used in this study was able to predict the temporal development of an AD process even under non-steady state conditions or non-constant substrate feeding. The key parameters of the model (B_0 , k , Y) were obtained by minimizing the objective function J , as defined in Section 2.4, that is the RSS between the set of experimental data and the theoretical curve of both methane production and VS into the digestate. The best fit parameters resulted $B_0 = 0.218 \text{ Nm}^3/\text{kg VS}$, $k = 0.380 \text{ d}^{-1}$ and $Y = 0.42$. Only few papers report these model parameters. Gianico and coauthors [1] obtained a B_0 value of $154 \text{ Nm}^3/\text{kg VS}$ testing a WAS sample collected directly from the oxidation tank operating at an average sludge age of 20 d.

3.3 Thermophilic digestion in the 240 L reactor (phase 2): model validation

The 240 L reactor was fed with 35 aliquots of secondary sludge during a period of approximately two months. The sludge had average TS and VS contents of 2.7% and 2.0%, respectively. In this case the ratio VS/TS was almost constant for all the duration of the test and equal to 72%.

As it can be seen from Figure 3, also in this test stable conditions were reached after approximately 25-30 days. At the steady state, the SMP was of $0.176 (\pm 0.003) \text{ Nm}^3/\text{kg VS fed}$. As expected, even in this case the sludge digested in thermophilic conditions produced more methane than the sludge digested in mesophilic conditions and the increment was of 47%. Furthermore, the obtained result in terms of SMP was in good agreement with the one obtained at a lower scale (44 L) test.

Even the digestion performed in the 240 L was stable, with a pH of 7.98 ± 0.25 , and constant VFA and TA values at 367 ± 32 mg equivalent $\text{CH}_3\text{COOH}/\text{l}$ and 3511 ± 202 mg equivalent CaCO_3/l respectively, as shown in Figure 5. Consequently, the VFA/TA ratio for all the duration of the test was stable at 0.10 ± 0.01 .

Figure 5. Evolution of the VFA and TA parameters into the digestate from the 240 L reactor, thermophilic conditions (55°C), HRT = 20 days

The key parameters of the model (B_0 , k) obtained from the test in the 44 L digester were used to predict the SMP of this larger (240 L) digester. Figure 6 reports the cumulative methane production over the whole period of the experimentation. It can be seen that there was a good agreement between the experimental data and those predicted by the model with the parameters obtained in the previous experimentation (44 L). The error was of less than 1% on the cumulative production.

Figure 6. Cumulative methane production (dots) and results of the modelling (solid curve) for a WAS digested in thermophilic conditions (55°C) in the 240 L reactor (HRT = 20 days)

The modelization was accurate enough to predict the daily methane production not only at steady-state but also during the start-up phase of the digester, as it can be seen from Figure 7. Furthermore, it can be underlined that the agreement between the experimental data and the model was very good even if in this second test (240 L) the VS/TS ratio of the substrate was higher than that of the WAS used in the 44 L test. Similarly to the outcome found by Montecchio and coauthors [38], the reason for the large short term variations in methane production shown in Figure 7 consisted in the peculiarity of the feeding operations; the reactor was fed daily for 5 days consecutively followed by 2 days' interruption over the

weekend. This resulted in a rise in methane production during the first 5 days followed by the drop at the week end.

Figure 7. Daily methane production (dots) and results of the modelling (solid curve) for a secondary sludge digested in thermophilic conditions in the 240 L reactor (HRT = 20 days)

This study demonstrated that the transition from a mesophilic to a thermophilic thermal regime enhanced the overall efficiency of the digestion process, through the improvement of the two key parameters of the model, namely B_0 and k . In fact, the production of methane at infinite time, B_0 , that is an indication of the extent of the degradability fraction, increased from $0.147 \text{ Nm}^3/\text{kg VS}$ in the mesophilic regime to $0.218 \text{ Nm}^3/\text{kg VS}$ in the thermophilic regime (+ 48%). The hydrolysis coefficient, k , experienced an increase of approximately 350%, going from 0.085 d^{-1} to 0.380 d^{-1} . The value of k is indicative of how fast the digestion process proceeds and previous studies demonstrated that it was sensitive to temperature, probably because of the emergence of true thermophiles at temperature of digestion higher than 50°C [39]. The increase in the digestion rate rather than in the degradability fraction observed in a thermophilic process was similar to the effects of mechanical pre-treatments, e.g. sonication [40, 41]. Conversely, high impact methods, such as thermal hydrolysis, provided substantial increases of rate and extent at the same time [42]. The combination of a slightly increase in the degradability of the substrate (+48%) and a very strong increase in the rate of the digestion processes (+ 350%) allowed to calculate an increase in the SMP of WAS, at a HRT = 20 days, from 0.093 to $0.193 \text{ Nm}^3/\text{kg VS fed}$ (+ 108%), moving from mesophilic to thermophilic conditions. It was interesting to underline that, with a HRT = 20 days, the amount of gas extracted from the substrate in mesophilic condition was 63% of the maximum producible amount (B_0), while a thermophilic process with the same HRT allowed to reach a production of 88% of the theoretical value.

The next Section (3.4) of the paper provides an assessment of the improvements given to the sludge line of a full scale WWTP (2M e.i.) after the substitution of the traditional mesophilic digestion of WAS with a thermophilic process.

3.4 Application of the results to a full scale WWTP

At the moment primary and secondary sludge produced in the SMAT Castiglione Torinese WWTP are digested in separated mesophilic reactors with an HRT in the order of 17 days. As reported in a previous work [43], each of the six Castiglione Torinese WWTP digesters has an overall volume of 12,000 m³, with a working capacity in the order of 80% and a consequent working volume of 9,600 m³. SMAT digesters treat a total amount of sludge of 4320 kg TS/h, where primary sludge is 64% (on a TS weight basis). A detailed analysis of the present management mode of the WWTP sludge line is provided in Ruffino et al [44].

The main characteristics of the two sludges used for the energy assessment carried out in this study are reported in Table 1.

Table 1. Main characteristics of primary and secondary sludge digested in the WWTP sludge line

	Primary sludge	Secondary sludge
Volumetric flow rate, m ³ /h	92.1	51.8
Average TS content, %	3.0	3.0
Average VS/TS ratio	0.72	0.69
Sludge temperature, °C	15	15
Digester temperature, °C	38	38
SMP, Nm ³ /kg VS	0.280	0.090
HRT, d	17, single stage	17, single stage

This analysis proposes three future scenarios where the thermophilic digestion of secondary sludge was introduced to substitute the present mesophilic process. In those future scenarios primary and secondary sludge were digested in separated reactors with different thermal regimes. The HRT of both (mesophilic

and thermophilic) digestion processes was fixed to 17 days. However, because in a thermophilic regime all metabolism kinetics are enhanced and degradation rates are increased, as demonstrated in this study, the digester dimensions could be reduced for a given load and may support the use of low HRTs (below the typical values of 15-20 days for a mesophilic thermal regime) [45]. Therefore, thermophilic AD demands lower capital and installation costs [9, 20]. However, this potential benefit was not taken into account in the assessments carried out in this study.

A scheme of the three scenarios is provided in Figure 8.

Figure 8. Scheme of the three future scenarios where the present mesophilic process was substituted with the thermophilic digestion of secondary sludge (Scenario 1. No heat recovery; Scenario 2. One heat recovery process; Scenario 3. Two heat recovery processes)

The three scenarios differed for the hypotheses made concerning the recovery and mutual exchange of heat. As it can be seen from Figure 8, in Scenario 1 both primary and secondary sludge were heated from the ambient temperature (15 °C) to the digestion temperature (38 °C and 55 °C, respectively) by using the heat recovered from the biogas combustion in combined heat and power (CHP) units, as shown in Equation 13.

$$Q_{38\text{ °C}} + Q_{55\text{ °C}} = Q_{AD} \quad (13)$$

Where $Q_{38\text{ °C}}$ is the amount of heat necessary to heat the primary sludge from 15 °C to 38 °C, $Q_{55\text{ °C}}$ is the amount of heat necessary to heat the secondary sludge from 15 °C to 55 °C and Q_{AD} is the heat obtained from the biogas generated in the AD process.

In the case of an extra heat necessity, because the biogas produced from the AD of the two sludges was not sufficient to provide the heat for sludge heating and the compensation of digester losses, that extra heat could be obtained from a boiler fed with natural gas. However, it has to be underlined that the

thermal power necessary to sustain the AD process under mesophilic conditions (or, in the future, in a mesophilic / thermophilic condition) is presently ensured not only by the thermal production of the CHP units but also by the heat recovery from two drying sludge units located in the sludge line. At present, the two heat inputs from CHP units and dryers are in some cases not sufficient to sustain the mesophilic digestion, especially in the coldest months. For this reason, some heat from a boiler fueled by natural gas is used. The heat recovered from the dryers was not taken into consideration for the purpose of this work, because the boundaries of the analyzed system included only the pre-thickeners, the anaerobic digesters and the CHP units. For this study, the efficiency of heat transfer between the CHP unit (or the boiler) and the cold sludge was hypothesized equal to 50%, 70% and 100%.

In Scenario 2 the cold primary sludge received heat from the thermophilic digestate ($D_{55\text{ °C}}$), so as its temperature was increased from 15 °C to 38 °C ($Q_{38\text{ °C}}$), as in Equation 14.

$$Q_{38\text{ °C}} = D_{55\text{ °C}} \ \& \ Q_{55\text{ °C}} = Q_{AD} \quad (14)$$

Conversely, as in Scenario 1, the temperature of secondary sludge was increased from 15 °C to 55 °C ($Q_{55\text{ °C}}$) (thermophilic conditions) thanks to the heat produced from the CHP unit or the boiler (Q_{AD}). In Scenario 2 only the heat from the hottest digestate was recovered.

Finally, in Scenario 3 two heat recovery processes were considered (Figure 8). Firstly, the heat from the thermophilic digestate ($D_{55\text{ °C}}$) was used to heat the cold secondary sludge ($Q_{55\text{ °C}}$). Secondly, the heat from the mesophilic digestate ($D_{38\text{ °C}}$) was used to heat the cold primary sludge ($Q_{38\text{ °C}}$). For both heating processes of cold primary and secondary sludge the missing heat was provided by the CHP (Q_{AD}) and, if that was not sufficient, by the boiler fed with natural gas, as described by Equation 15.

$$Q_{55\text{ °C}} = D_{55\text{ °C}} + Q_{AD} \ \& \ Q_{38\text{ °C}} = D_{38\text{ °C}} + Q_{AD} \quad (15)$$

In the last two Scenarios, for the energy analysis, the three values of exchange efficiencies between the digestate and the cold sludge of 50%, 70% and 100% were considered. Furthermore, to complete the energy analysis, the sludge specific heat was assumed of 4186 kJ/m³·K, the lower heating value of

methane of 35,880 kJ/Nm³ and the indicative heat lost from the digesters walls and roofs was estimated equal to 158,500 kJ/h.

Figure 9 shows the results of the energy analysis carried out on the present sludge management mode and on a future situation where the mesophilic digestion of secondary sludge was substituted with a thermophilic process. In both cases, as in the present WWTP conditions, the heating of cold sludge and the compensation of heat losses through digesters' walls and roofs was obtained with the heat provided by the CHP unit and the boiler. As already seen in a previous work [44], TS contents of 4.7%, 6.7% and 9.4% in both primary and secondary sludges, for energy exchange efficiencies of 100%, 70% and 50% respectively, were necessary to make the energy balance of the whole set of digesters neutral, that is the heat coming from the biogas combustion was sufficient to heat both sludge volumetric flow rates and compensate the heat losses through the walls and roofs of the digesters. When the mesophilic digestion of the secondary sludge was substituted with a thermophilic process, the TS contents of both sludges that made the energy balance neutral were of 4.9%, 7.0% and 9.8%. This result proved that, in the absence of a heat recovery option, the increase in the methane productivity of the secondary sludge digested in a thermophilic regime, was not sufficient to balance the extra amount of heat required to heat the sludge from 15 °C to 55 °C.

Figure 9. Results of the energy analysis carried out on the present sludge management mode and on a future situation where the mesophilic digestion of secondary sludge was substituted with a thermophilic process (Scenario 1)

Partial or complete heat recovery practices allowed a significant improvement in the sludge management mode. From Figure 10 it can be seen that a single heat recovery step, that is the heat exchange between the hot thermophilic digestate (55 °C) and the cold primary sludge (15 °C), allowed to completely avoid

the need of the auxiliary fuel (natural gas) already with the present sludge TS content obtained with the thickeners available in the WWTP. This result was achievable provided that the heat exchange efficiency between hot and cold substrate was of 100%. In the case the heat exchange efficiency was only of 70% or 50% the TS content of both primary and secondary sludges necessary to make the overall energy balance neutral was of 4.8% and 7.6% respectively.

Figure 10. Results of the energy analysis carried out on a future situation where the mesophilic digestion of secondary sludge was substituted with a thermophilic process (Scenario 2 and Scenario 3)

Finally, when a complete heat recovery was applied, as in Scenario 3, the neutrality of the heat balance with the present TS content of sludge was obtained already with heat exchange efficiencies of 70%. Conversely, lower heat exchange efficiency (i.e. 50%) required a thickening of both primary and secondary sludge to TS values of 5.2%.

Following the same approach, it was possible to calculate the volumetric flow rates of natural gas saved after the introduction of practices of heat exchange between hot digestates and cold sludge. These results are shown in Figure 11.

Figure 11. Volumetric flow rates of natural gas (methane) saved after the introduction of practices of heat exchange between hot digestates and cold sludge (one, 1R, and two, 2R, heat recovery processes)

For example, it can be seen from Figure 11 that a heat transfer/exchange efficiency of 100%, in the presence of a single heat recovery step, required volumetric flow rates of natural gas of 197 and 67 Nm³/h in the presence of sludge TS content of 3% and 4% respectively. As said previously TS contents of at least 5% made the heat balance neutral without the need of external fuel. Conversely, a double heat

recovery step allowed to avoid the need of extra fuel (natural gas) at the sludge thickening degrees (TS = 3%) presently obtained in the WWTP with gravity thickeners.

Conclusions

The results obtained in this study allowed to come to three main conclusions. First of all, the transition from a mesophilic to a thermophilic thermal regime enhanced the overall efficiency of the digestion process without losing stability. An increase in the SMP of WAS equal to 108%, that is from 0.093 to 0.193 Nm³/kg VS fed, at HRT equal to 20 days, was calculated. After the increase of the digestion temperature, the two key parameters, namely B₀ and k, used to describe the digestion process, increased by 48% (from 0.147 Nm³/kg VS fed in the mesophilic regime to 0.218 Nm³/kg VS fed in the thermophilic regime) and 350% (from 0.085 d⁻¹ to 0.350 d⁻¹) respectively, similarly to the effects of mechanical pre-treatments, e.g. sonication.

Secondly, even a simple model, like the one used in this study, that describes the digestion process with a first order rate reaction, proved to be very useful for design purposes, that is the estimation of digester volume, biogas production, degradation rate or feed flow rate, when boundary conditions changes. The two parameters, B₀ and k, obtained from the experimentation carried out in the 44 L digester, were able to predict the SMP of WAS from a larger scale digester (240 liters) with an error of only 1%.

Finally, the application of mass and heat balances to the sludge line of the full scale WWTP allowed to assess that the substitution of the present mesophilic digestion of WAS with a thermophilic process could be self-sustainable, from an energy point of view, at sludge TS contents of approximately 5%, when a heat exchange with an efficiency of 70% was applied between hot digestates and cold sludge. The combination of the thermophilic digestion process of WAS and an efficient heat exchange allowed to save volumes of natural gas of 100 – 200 Nm³/h, depending on the scheme of heat recovery between digestate and raw sludge, otherwise necessary to guarantee the process temperature into the digesters.

Acknowledgements

This research was funded by SMAT, Società Metropolitana Acque Torino.

The authors wish to thank Gaia Gentilucci and Enrico Reusa for the support in the experimental activity.

References

- [1] A. Gianico, C.M. Braguglia, R. Cesarini, G. Mininni, Reduced temperature hydrolysis at 134°C before thermophilic anaerobic digestion of waste activated sludge at increasing organic load. *Bioresource Technol* 143 (2013) 96–103. <http://dx.doi.org/10.1016/j.biortech.2013.05.069>
- [2] W.R.M. Leite, M. Gottardo, P. Pavan, P. Belli Filho, D. Bolzonella, Performance and energy aspects of single and two phase thermophilic anaerobic digestion of waste activated sludge. *Renew Energ* 86 (2016) 1324-1331. <http://dx.doi.org/10.1016/j.renene.2015.09.069>
- [3] D. Bolzonella, P. Pavan, P. Battistoni, F. Cecchi, Mesophilic anaerobic digestion of waste activated sludge: influence of the solid retention time in the wastewater treatment process. *Process Biochem* 40 (3–4) (2005) 1453-1460. <https://doi.org/10.1016/j.procbio.2004.06.036>
- [4] D. Traversi, V. Romanazzi, R. Degan, E. Lorenzi, E. Carraro, G. Gilli, Microbial-chemical indicator for anaerobic digester performance assessment in full-scale wastewater treatment plants for biogas production. *Bioresource Technol* 186 (2015) 179-191. DOI: 10.1016/j.biortech.2015.03.042
- [5] B. Xiao, C. Liu, J. Liu, X. Guo, Evaluation of the microbial cell structure damages in alkaline pretreatment of waste activated sludge. *Bioresource Technol* 196 (2015) 109-115. [10.1016/j.biortech.2015.07.056](http://dx.doi.org/10.1016/j.biortech.2015.07.056)
- [6] A. Gonzalez, A.T.W.M. Hendriks, J.B. van Lier, M. de Kreuk, Pre-treatments to enhance the biodegradability of waste activated sludge: Elucidating the rate limiting step. *Biotechnol Adv* 36 (2018) 1434–1469. <https://doi.org/10.1016/j.biotechadv.2018.06.001>
- [7] M.P. Caporgno, R. Trobajo, N. Caiola, C. Ibáñez, A. Fabregat, C. Bengoa, Biogas production from sewage sludge and microalgae co-digestion under mesophilic and thermophilic conditions. *Renew Energ* 75 (2015) 374-380. <http://dx.doi.org/10.1016/j.renene.2014.10.019>
- [8] D. Almeida Streitwieser, Comparison of the anaerobic digestion at the mesophilic and thermophilic temperature regime of organic wastes from the agribusiness. *Bioresource Technol* 241 (2017) 985–992. <http://dx.doi.org/10.1016/j.biortech.2017.06.006>
- [9] W. Leite, B. Scandolaro Magnus, L. Bittencourt Guimarães, M. Gottardo, P. Belli Filho, Feasibility of thermophilic anaerobic processes for treating waste activated sludge under low HRT and intermittent mixing. *J Environ Manage*, 201 (2017) 335-344. <http://dx.doi.org/10.1016/j.jenvman.2017.06.069>
- [10] C. Da Ros, C. Cavinato, P. Pavan, D. Bolzonella, Mesophilic and thermophilic anaerobic co-digestion of winery wastewater sludge and wine lees: An integrated approach for sustainable wine production. *J Environ Manage* 203 (2017) 745-752. <http://dx.doi.org/10.1016/j.jenvman.2016.03.029>
- [11] Q. Li, X. Cheng, C. Yuwen, X. Yang, W. Qiao, Y.Y. Li, X. Wang, Strategies for the stable performance and rapid inhibition recovery of a thermophilic digester treating coffee wastes and the synergistic effects of microbes. *Int Biodeter Biodegr* 132 (2018) 114–121. <https://doi.org/10.1016/j.ibiod.2018.02.014>
- [12] M. Takashima, Effects of Thermal Pretreatment and Trace Metal Supplementation on High-Rate Thermophilic Anaerobic Digestion of Municipal Sludge. *J Environ Eng* 144(3) (2018) 04018009. DOI: 10.1061/(ASCE)EE.1943-7870.0001340
- [13] L.J. Wu, A. Higashimori, Y. Qin, T. Hojo, K. Kubota, Y.Y. Li, Comparison of hyper-thermophilic–mesophilic two-stage with single-stage mesophilic anaerobic digestion of waste activated sludge: Process performance and microbial community analysis. *Chem Eng J* 290 (2016) 290–301. <http://dx.doi.org/10.1016/j.cej.2016.01.067>

- [14] Y. Qin, A. Higashimoria, L.J. Wu, T. Hojo, K. Kubota, Y.Y. Li, Phase separation and microbial distribution in the hyperthermophilic- mesophilic- type temperature-phased anaerobic digestion (TPAD) of waste activated sludge (WAS). *Bioresource Technol* 245 (2017) 401–410. <http://dx.doi.org/10.1016/j.biortech.2017.08.124>
- [15] R.M. Alqaralleh, K. Kennedy, R. Delatolla, M. Sartaj, Thermophilic and hyper-thermophilic co-digestion of waste activated sludge and fat, oil and grease: Evaluating and modeling methane production. *J Environ Manage* 183 (2016) 551-561. <http://dx.doi.org/10.1016/j.jenvman.2016.09.003>
- [16] R.M. Alqaralleh, K. Kennedy, R. Delatolla, Improving biogas production from anaerobic co-digestion of Thickened Waste Activated Sludge (TWAS) and fat, oil and grease (FOG) using a dual-stage hyper-thermophilic/thermophilic semi-continuous reactor, *J Environ Manage* 217 (2018) 416-428. <https://doi.org/10.1016/j.jenvman.2018.03.123>
- [17] B. Xiao, Y. Qin, W. Zhang, J. Wu, H. Qiang, J. Liu, Y.Y. Li, Temperature-phased anaerobic digestion of food waste: A comparison with single-stage digestions based on performance and energy balance. *Bioresource Technol* 249 (2018) 826–834. <http://dx.doi.org/10.1016/j.biortech.2017.10.084>
- [18] T. Wang, J. Chen, H. Shen, D. An, Effects of total solids content on waste activated sludge thermophilic anaerobic digestion and its sludge dewaterability. *Bioresource Technol* 217 (2016) 265–270. <http://dx.doi.org/10.1016/j.biortech.2016.01.130>
- [19] J.A. Villamil, A.F. Mohedano, J. San Martín, J.J. Rodriguez, M.A. de la Rubia, Anaerobic co-digestion of the process water from waste activated sludge hydrothermally treated with primary sewage sludge. A new approach for sewage sludge management. *Renew Energ* 146 (2020) 435-443. <https://doi.org/10.1016/j.renene.2019.06.138>
- [20] G.D. Zupančič, M. Roš, Heat and energy requirements in thermophilic anaerobic sludge digestion. *Renew Energ* 28 (24) (2003) 2255-2267. [https://doi.org/10.1016/S0960-1481\(03\)00134-4](https://doi.org/10.1016/S0960-1481(03)00134-4)
- [21] I. Ferrer, E. Serrano, S. Ponsá, F. Vázquez, X. Font, Enhancement of Thermophilic Anaerobic Sludge Digestion by 70 °C Pre-Treatment: Energy Considerations. *J Residuals Sci Tech* 6 (1) (2009) 11-18.
- [22] G. Zhang, Z. Wu, F. Cheng, Z. Min, D.J. Lee, Thermophilic digestion of waste-activated sludge coupled with solar pond. *Renew Energ* 98 (2016) 142-147. <http://dx.doi.org/10.1016/j.renene.2016.03.052>
- [23] D.J. Batstone, V.A. Vavilin, J. Keller, I. Angelidaki, S.V. Kalyuzhnyi, S.G. Pavlostathis, A. Rozzi, W.T.M. Sanders, H. Siegrist, V.A. Vavilin, The IWA anaerobic digestion model no 1 (ADM1). *Water Sci. Technol.* 45 (2002) 65 LP-73.
- [24] D. Lu, K. Xiao, Y. Chen, Y.N.A. Soh, Y. Zhou, Transformation of dissolved organic matters produced from alkaline ultrasonic sludge pretreatment in anaerobic digestion: From macro to micro. *Water Res* 142 (2018) 138-146. <https://doi.org/10.1016/j.watres.2018.05.044>
- [25] X. Zhou, Q. Wang, G. Jiang, Enhancing methane production from waste activated sludge using a novel indigenous iron activated peroxidation pre-treatment process. *Bioresource Technol* 182 (2015) 267–271. <http://dx.doi.org/10.1016/j.biortech.2015.01.132>
- [26] B. Ruffino, G. Campo, M.C. Zanetti, G. Genon, Improvement of activated sludge anaerobic digestion: thermal and economical perspectives. *WIT Trans. Ecol. Environ.* 190 (2014) 979–991. DOI: 10.2495/EQ140922

- [27] N.M.G. Coelho, R.L. Droste, K.J. Kennedy, Evaluation of continuous mesophilic, thermophilic and temperature phased anaerobic digestion of microwaved activated sludge. *Water Res* 45 (2011) 2822-2834. doi:10.1016/j.watres.2011.02.032
- [28] APHA, AWWA, WEF. *Standard methods for the examination of water and wastewater*, 22nd ed., Washington: American Public Health Association, ISBN 978-087553-013-0; 2012.
- [29] W. Nordmann. *Die Überwachung der Schlammfäulung*. KA-Informationen für das Betriebspersonal, Beilage zur Korrespondenz Abwasser, 3/77; 1977 (in German)
- [30] Y. Wu, A. Kovalovszki, J. Pan, C. Lin, H. Liu, N. Duan, I. Angelidaki, Early warning indicators for mesophilic anaerobic digestion of corn stalk: a combined experimental and simulation approach. *Biotechnol Biofuels* (2019) 12:106, <https://doi.org/10.1186/s13068-019-1442-7>
- [31] G. Zhen, X. Lu, H. Kato, Y. Zhao, Y.Y. Li, Overview of pretreatment strategies for enhancing sewage sludge disintegration and subsequent anaerobic digestion: Current advances, full-scale application and future perspectives. *Renew Sust Energ Rev* 69 (2017) 559–577, <https://doi.org/10.1016/j.rser.2016.11.187>
- [32] D.J. Batstone, P.F. Pind, I. Angelidaki, Kinetics of Thermophilic, Anaerobic Oxidation of Straight and Branched Chain Butyrate and Valerate. *Biotechnol Bioeng* 84 (2) (2003) 195-204.
- [33] W. Wei, X. Zhou, D. Wang, J. Sun, Q. Wang, Free ammonia pre-treatment of secondary sludge significantly increases anaerobic methane production. *Water Res* 118 (2017) 12-19. <http://dx.doi.org/10.1016/j.watres.2017.04.015>
- [34] J.A. Siles, M.A. Martín, A. Chica, R. Borja, Kinetic modelling of the anaerobic digestion of wastewater derived from the pressing of orange rind produced in orange juice manufacturing. *Chem Eng J* 140 (2008) 145–156. doi:10.1016/j.cej.2007.09.026
- [35] A. do Carmo Precci Lopes, C. Mudadu Silva, A. Pereira Rosa, F. de Avila Rodrigues, Biogas production from thermophilic anaerobic digestion of kraft pulp mill sludge. *Renew Energ* 124 (2018) 40-49. <http://dx.doi.org/10.1016/j.renene.2017.08.044>
- [36] C.M. Braguglia, A. Gianico, A. Gallipoli, G. Mininni, The impact of sludge pre-treatments on mesophilic and thermophilic anaerobic digestion efficiency: Role of the organic load. *Chem Eng J* 270 (2015) 362–371. <http://dx.doi.org/10.1016/j.cej.2015.02.037>
- [37] Q. Li, H. Li, G. Wang, X. Wang, Effects of loading rate and temperature on anaerobic co-digestion of food waste and waste activated sludge in a high frequency feeding system, looking in particular at stability and efficiency. *Bioresour Technol* 237 (2017) 231–239. <http://dx.doi.org/10.1016/j.biortech.2017.02.045>
- [38] D. Montecchio, C.M. Braguglia, A. Gallipoli, A. Gianico, A model-based tool for reactor configuration of thermophilic biogas plants fed with Waste Activated Sludge. *Renew Energ* 113 (2017) 411-419. <http://dx.doi.org/10.1016/j.renene.2017.05.082>
- [39] Q. Wang, L. Ye, G. Jiang, P.D. Jensen, D.J. Batstone, Z. Yuan, A novel free nitrous acid (FNA)-based technology for enhancing methane production from waste activated sludge. *Environ Sci Technol* 47 (2013) 11897–11904
- [40] X. Li, S. Guo, Y. Peng, Y. He, S. Wang, L. Li, M. Zhao, Anaerobic digestion using ultrasound as pretreatment approach: Changes in waste activated sludge, anaerobic digestion performances and digestive microbial populations. *Biochem Eng J* 139 (2018) 139-145. DOI: 10.1016/j.bej.2017.11.009

- [41] M. Tytła, The effects of ultrasonic disintegration as a function of waste activated sludge characteristics and technical conditions of conducting the process—Comprehensive analysis. *International Journal of Environmental Research and Public Health*, 15(10) (2018) 2311. DOI: 10.3390/ijerph15102311
- [42] H. Ge, P.D. Jensen, D.J. Batstone, Temperature phased anaerobic digestion increases apparent hydrolysis rate for waste activated sludge, *Water Res* 45 (2011) 1597 – 1606. doi:10.1016/j.watres.2010.11.042
- [43] G. Campo, A. Cerutti, M.C. Zanetti, G. Scibilia, E. Lorenzi, B. Ruffino, Enhancement of waste activated sludge (WAS) anaerobic digestion by means of pre- and intermediate treatments. Technical and economic analysis at a full scale WWTP. *J Environ Manage* 216 (2018) 372-382. DOI: 10.1016/j.jenvman.2017.05.025.
- [44] B. Ruffino, A. Cerutti, G. Campo, G. Scibilia, E. Lorenzi, M.C. Zanetti, Improvement of energy recovery from the digestion of waste activated sludge (WAS) through intermediate treatments: The effect of the hydraulic retention time (HRT) of the first-stage digestion. *Appl Energ* 240 (2019) 191-204. DOI: 10.1016/j.apenergy.2019.02.061
- [45] J. De Vrieze, D. Smet, J. Klok, J. Colsen, L.T. Angenent, S.E. Vlaeminck, Thermophilic sludge digestion improves energy balance and nutrient recovery potential in full-scale municipal wastewater treatment plants. *Bioresour Technol* 218 (2016) 1237-1245. <http://dx.doi.org/10.1016/j.biortech.2016.06.119>

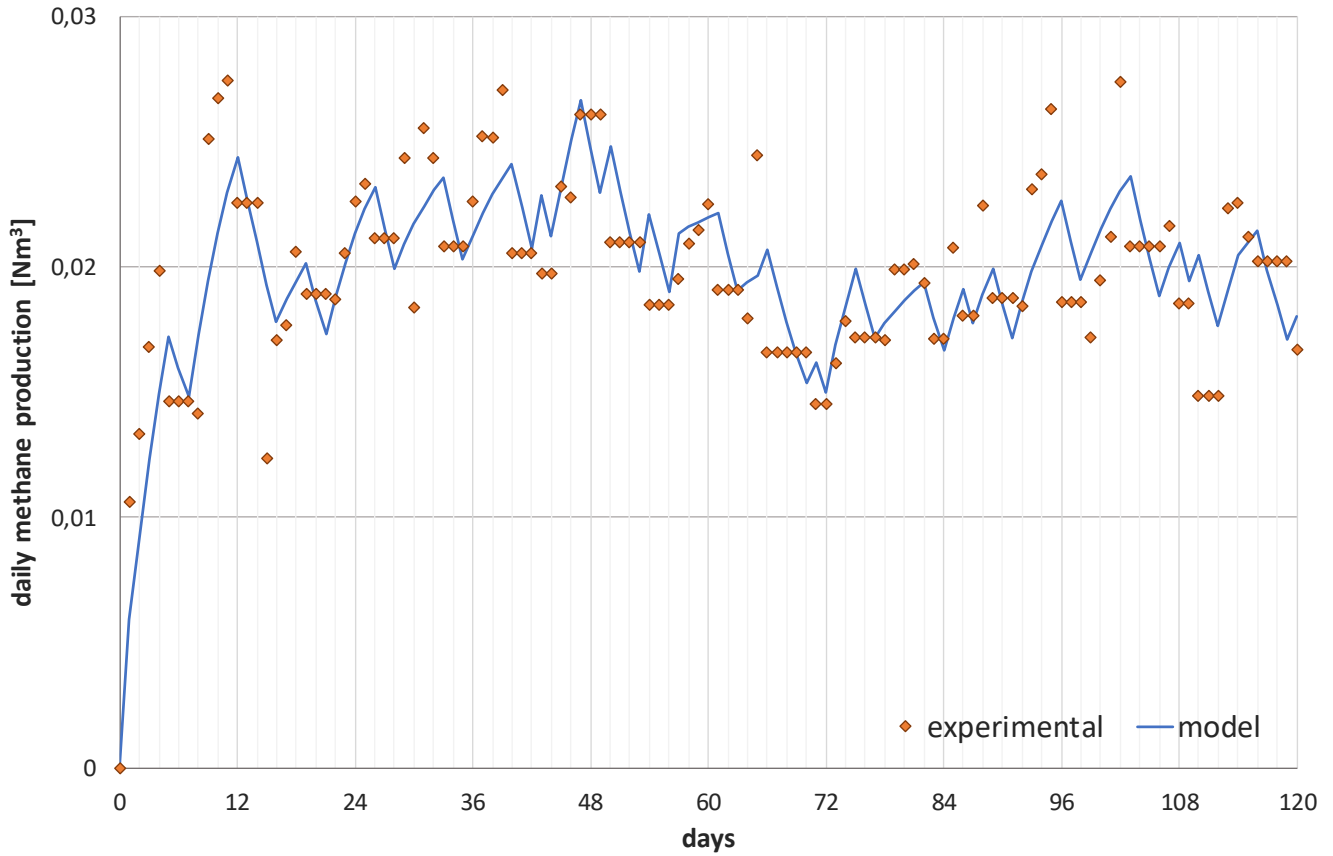

Figure 1. Daily methane production (dots) and results of the modelling (solid curve) for a WAS digested in mesophilic conditions (38 °C) in the 240 L reactor (HRT = 20 days)

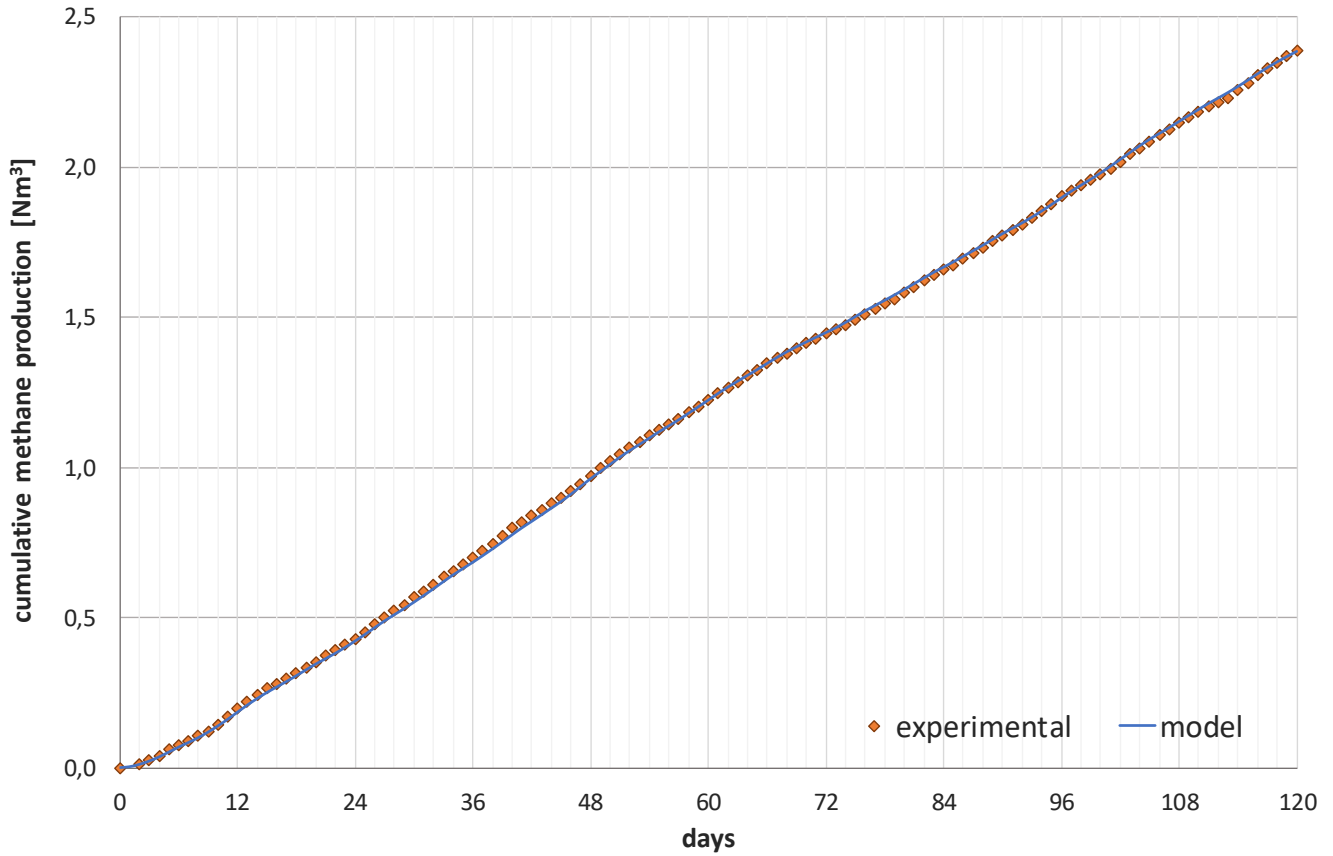

Figure 2. Cumulative methane production (dots) and results of the modelling (solid curve) for a WAS digested in mesophilic (38 °C) conditions in the 240 L reactor (HRT = 20 days)

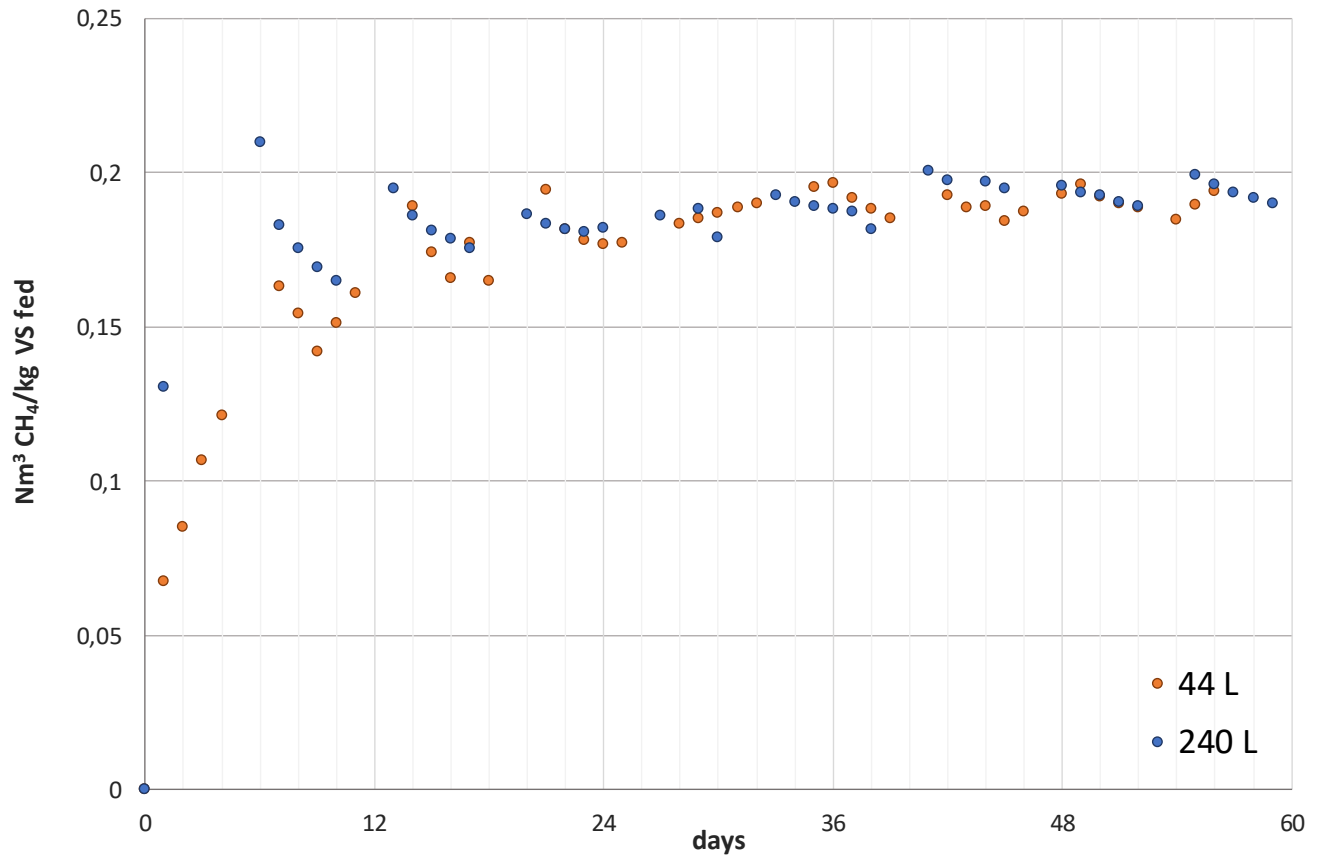

Figure 3. Evolution of the SMP from the 44 L and 240 L reactors, thermophilic conditions (55 °C), HRT = 20 days

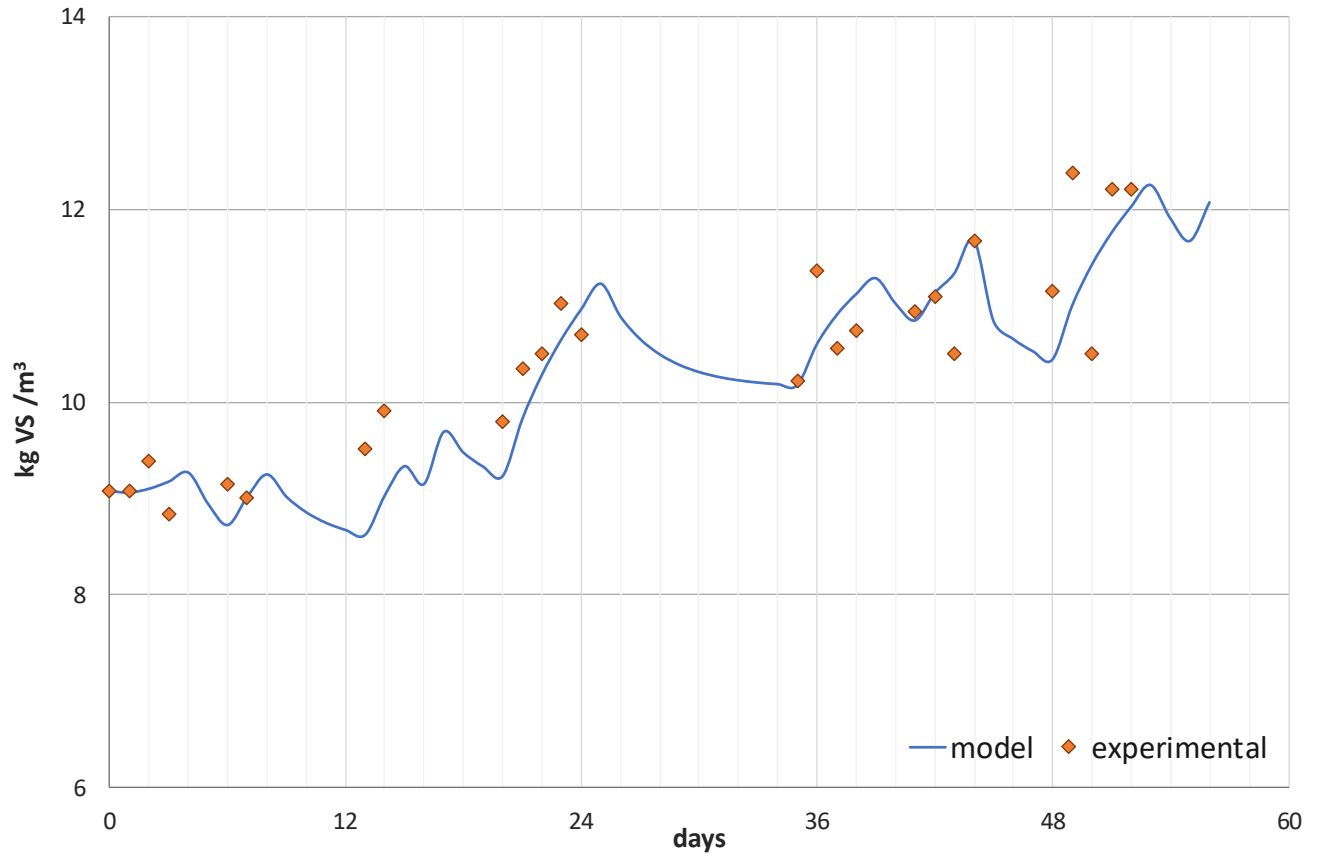

Figure 4. Evolution of the residual VS into the digestate, 44 L reactor, thermophilic conditions, HRT = 20 days, experimental data (dots) and model (solid curve)

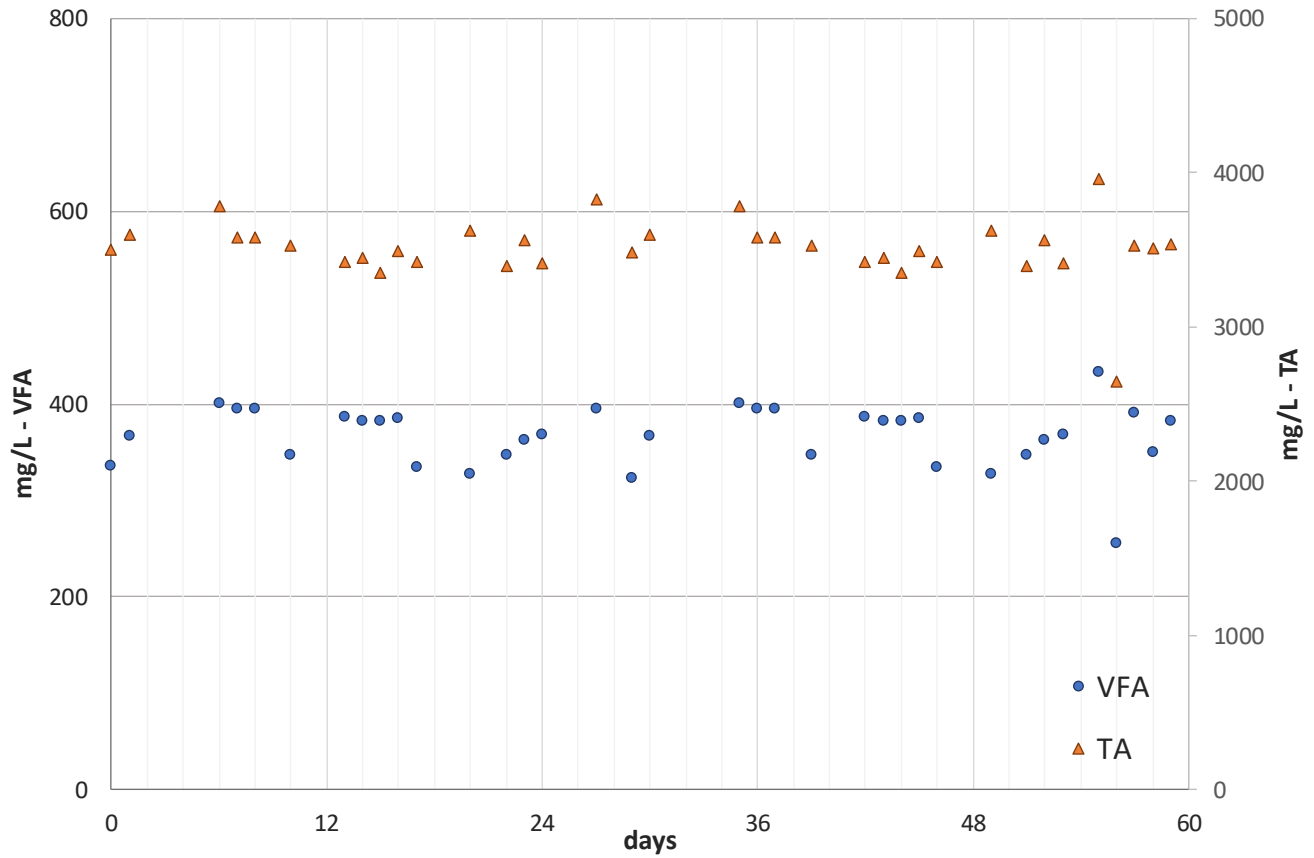

Figure 5. Evolution of the VFA and TA parameters into the digestate from the 240 L reactor, thermophilic conditions (55 °C), HRT = 20 days

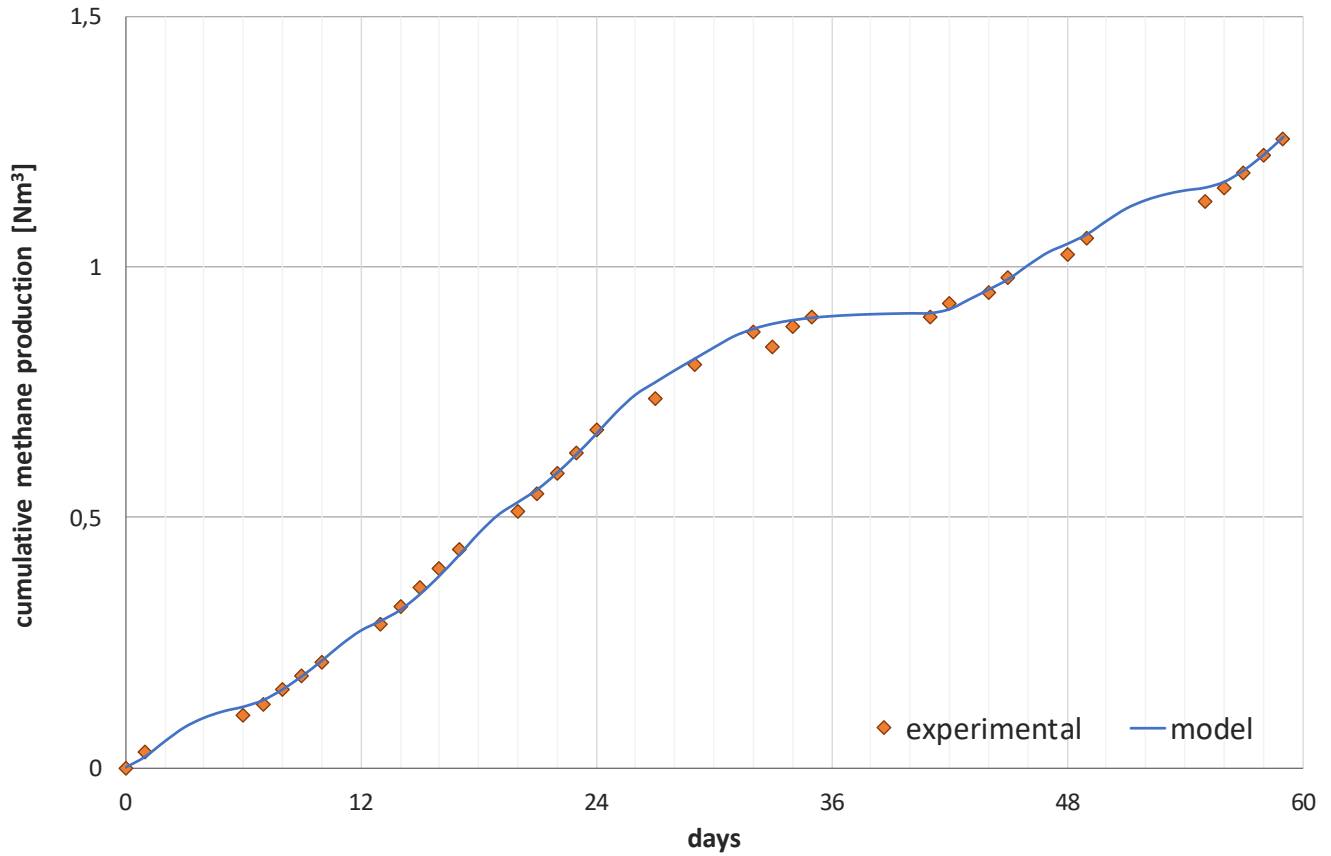

Figure 6. Cumulative methane production (dots) and results of the modelling (solid curve) for a WAS digested in thermophilic conditions (55 °C) in the 240 L reactor (HRT = 20 days)

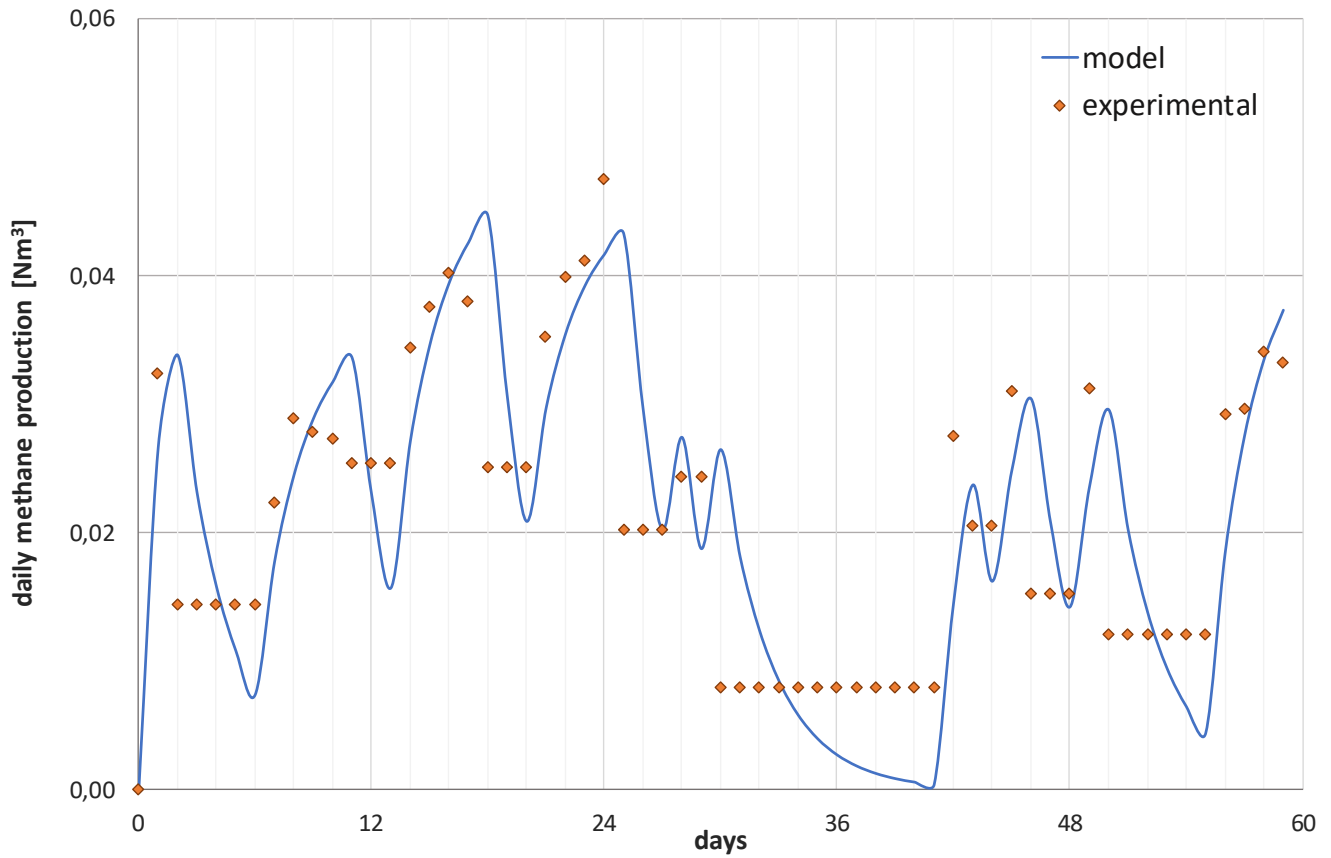
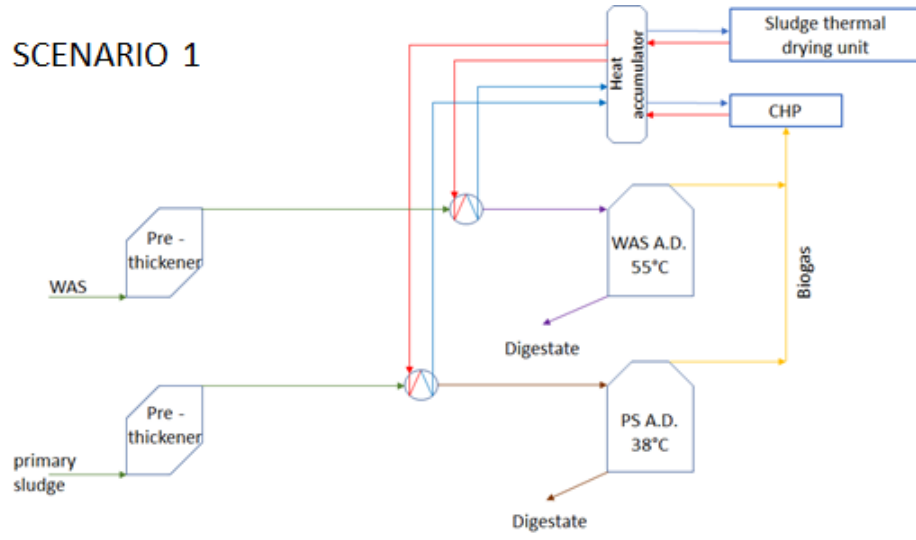
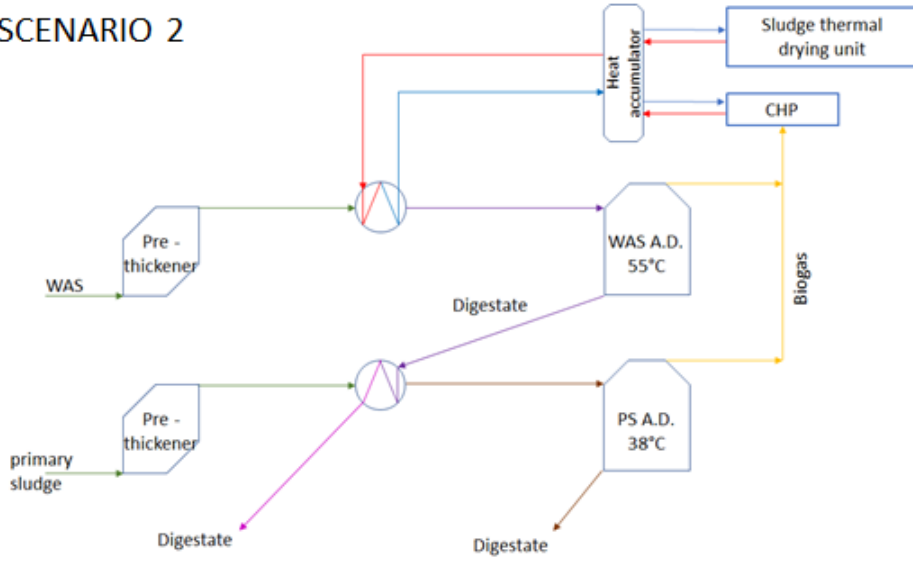

Figure 7. Daily methane production (dots) and results of the modelling (solid curve) for a secondary sludge digested in thermophilic conditions in the 240 L reactor (HRT = 20 days)

SCENARIO 1



SCENARIO 2



SCENARIO 3

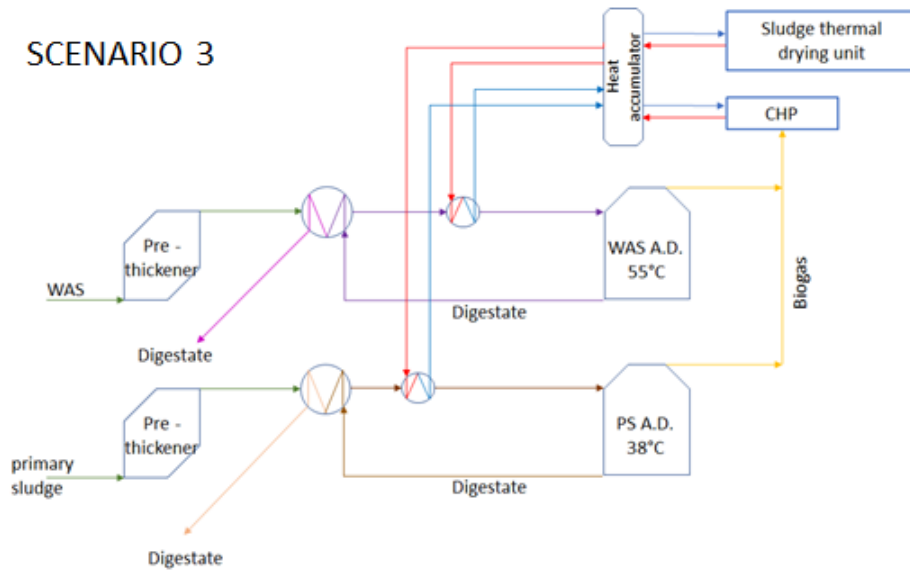
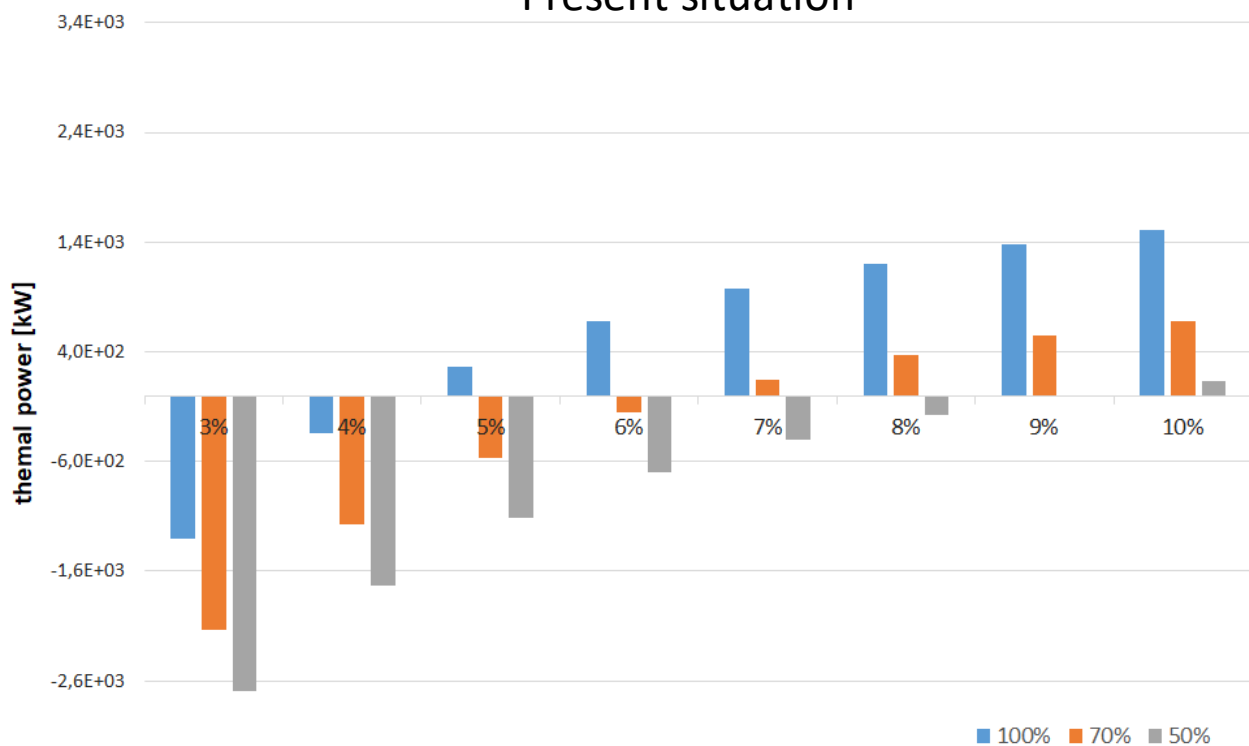

Figure 8. Scheme of the three future scenarios where the present mesophilic process was substituted with the thermophilic digestion of secondary sludge (Scenario 1. No heat recovery; Scenario 2. One heat recovery process; Scenario 3. Two heat recovery processes)

Present situation



TS content

Scenario 1

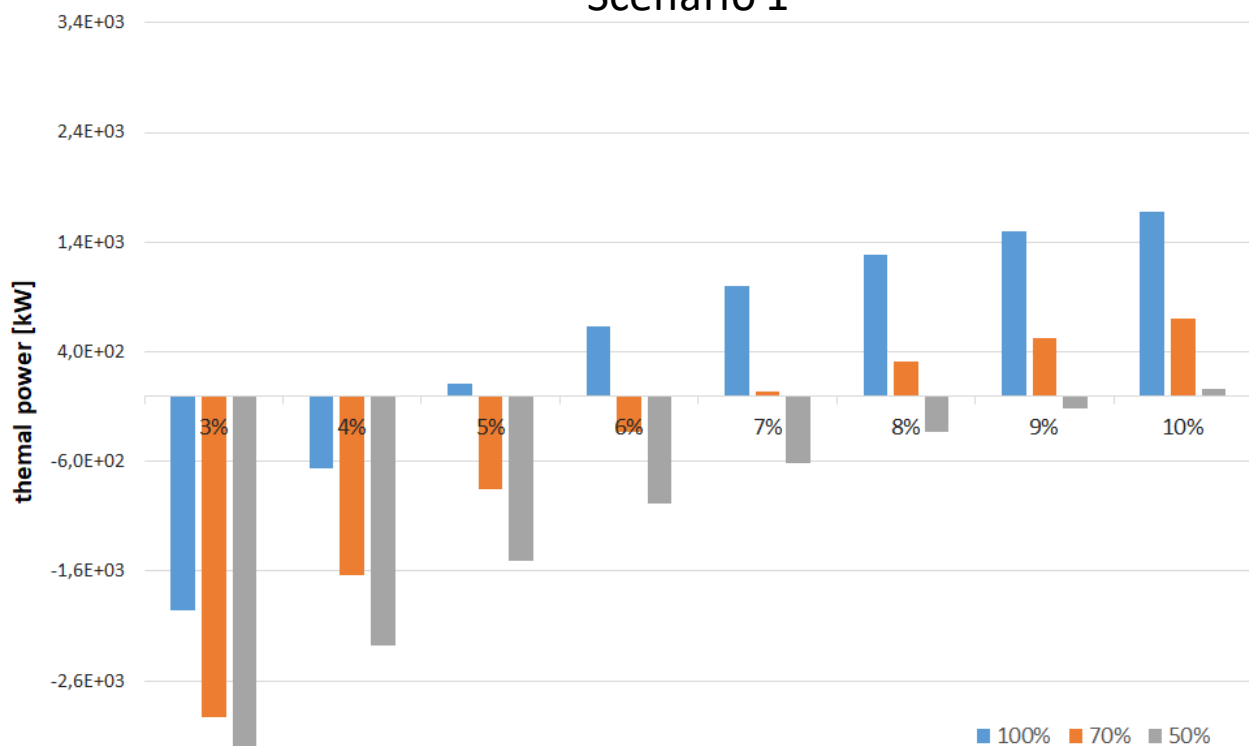

TS content

Figure 9. Results of the energy analysis carried out on the present sludge management mode and on a future situation where the mesophilic digestion of secondary sludge was substituted with a thermophilic process (Scenario 1)

Scenario 2

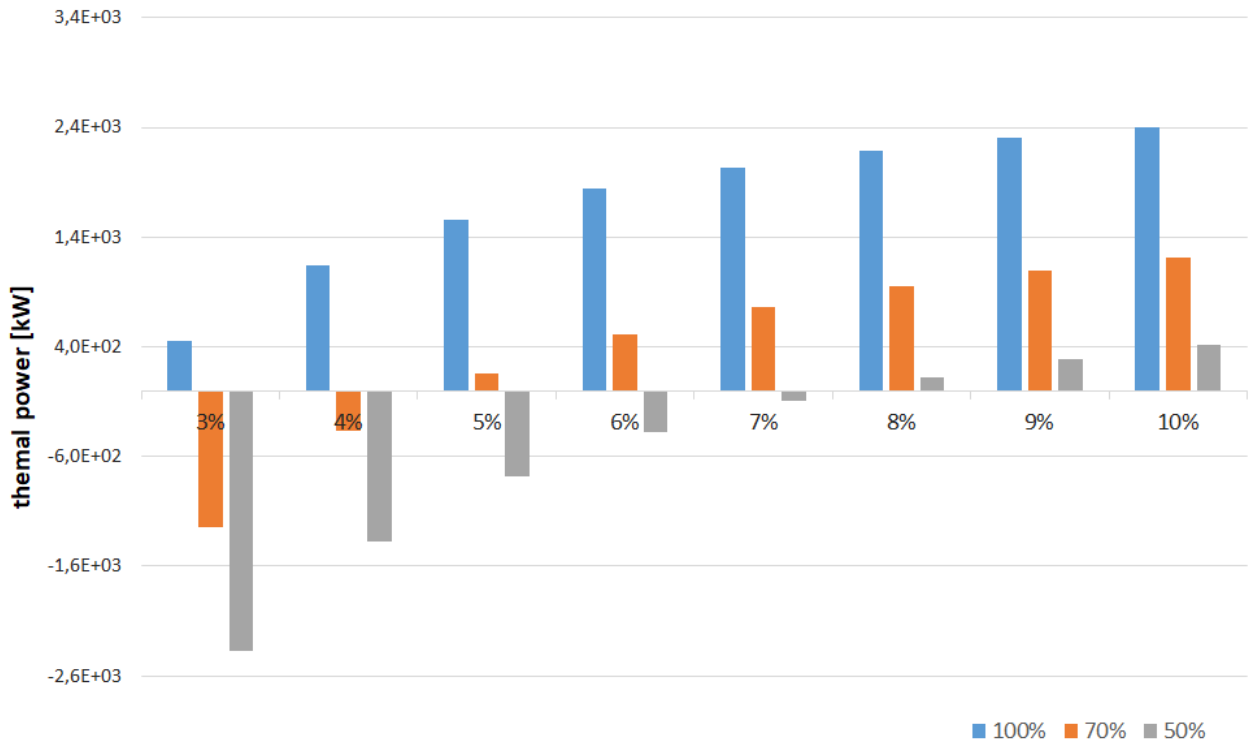

TS content

Scenario 3

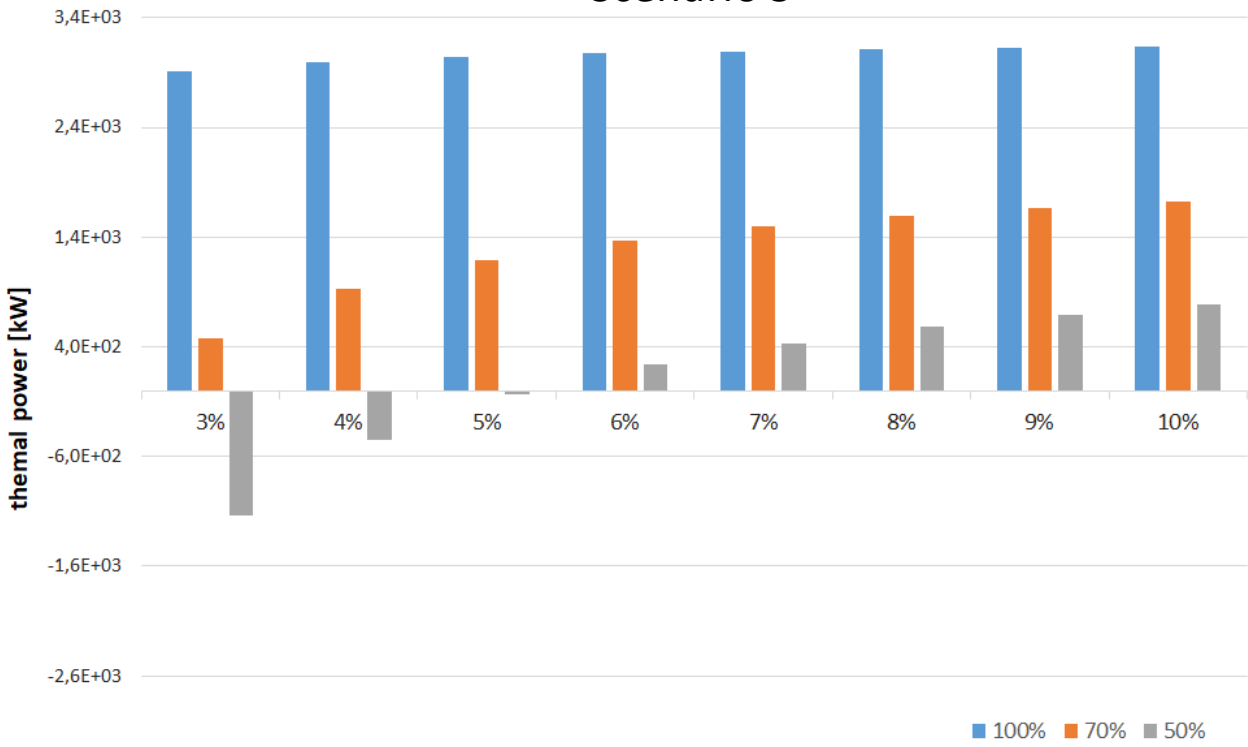

TS content

Figure 10. Results of the energy analysis carried out on a future situation where the mesophilic digestion of secondary sludge was substituted with a thermophilic process (Scenario 2 and Scenario 3)

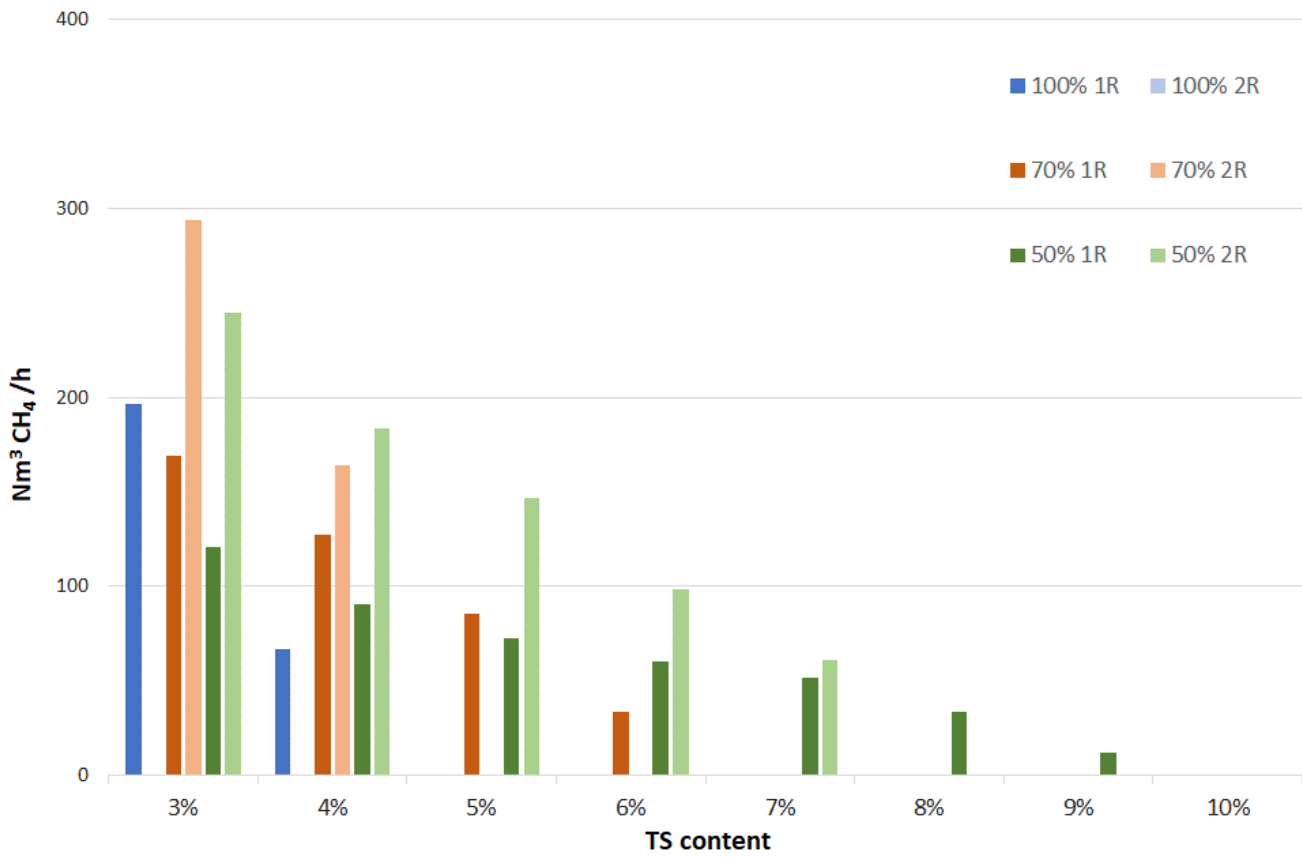

Figure 11. Volumetric flow rates of natural gas (methane) saved after the introduction of practices of heat exchange between hot digestates and cold sludge (one, 1R, and two, 2R, heat recovery processes)