

Experimental validation of a FEM-aided structural design of an eco-sustainable high performance made skiff

*Original*

Experimental validation of a FEM-aided structural design of an eco-sustainable high performance made skiff / Fontana, M.; Glorioso, M.; Pilagatti, A.; Moscoloni, C.; Mattiazzo, G.. - ELETTRONICO. - (2020), pp. 233-237. (Intervento presentato al convegno 2019 IMEKO TC19 International Workshop on Metrology for the Sea: Learning to Measure Sea Health Parameters, MetroSea 2019 tenutosi a Genova (ITA) nel 2019).

*Availability:*

This version is available at: 11583/2837102 since: 2020-06-23T12:50:13Z

*Publisher:*

IMEKO-International Measurement Federation Secretariat

*Published*

DOI:

*Terms of use:*

This article is made available under terms and conditions as specified in the corresponding bibliographic description in the repository

*Publisher copyright*

(Article begins on next page)

**POLITECNICODITORINO**  
**RepositoryISTITUZIONALE**

**Experimental validation of a FEM-aided structural design of an eco-sustainable high performance made skiff**

*Original*

Experimental validation of a FEM-aided structural design of an eco-sustainable high performance made skiff/Fontana, M.; Glorioso, M.; Pilagatti, A.; Moscoloni, C.; Mattiazzo, G..-ELETTRONICO.- (2020), pp. 233-23 . (Intervento presentato al convegno 2019 IMEKO TC19 International Workshop on Metrology for the Sea: Learning to Measure Sea Health Parameters, MetroSea 2019 tenuto a Genova (ITA) nel 2019).

*Availability:*

This version is available at: 11583/283 102 since: 2020-06-23T12:50:13Z

*Publisher:*

IMEKO-International Measurement Federation Secretariat

*Published*

DOI:

*Terms of use:*

This article is made available under terms and conditions as specified in the corresponding bibliographic description in the repository

*Publisher copyright*

(Article begins on next page)

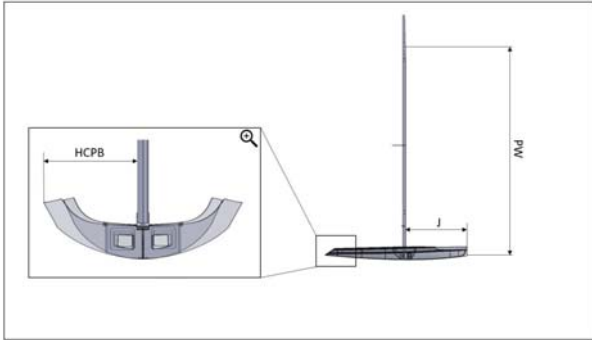

Fig. 2. Characteristic Dimensions.

an imposed displacement located at the ends of the cables. Anyway, the physical behaviour of a steel cable should consider that the compressive stresses are negligible, however the ROD element doesn't contemplate this phenomenon. In order to fix this problem, it was necessary acting on the material behaviour designing a bi-linear steel in which for negative strains the Young's modulus is negligible, as shown in Fig 3.

The imposed displacements have been obtained considering the first setup adopted before the starting. The loads measured in the harbour are equal to:

- Shroud: 1128 N;
- Chainplates: 1569.6 N

These force values have been converted in displacement through the following equation:

$$\delta L = \frac{F \cdot L}{E \cdot A} \quad (2)$$

Where:

- F = force recorded;
- L = cable length;
- E = Young's modulus;
- A = cable section area.

### C. CFD to FEM Transfer Algorithm

The hull pressures have been obtained in a CFD environment in which it is considered a speed of 6 knt without waves. The most important problem is to transfer the pressures calculated at the forequarter of the element to the FEM environment, in which the load is applied at the middle of the element. To overcome this limit, a simple transfer algorithm has been designed. In fact, the same division pattern between CFD and FEM hull model has

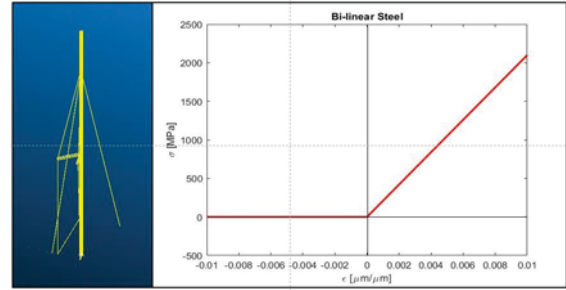

Fig. 3. 1D Model and Material Design.

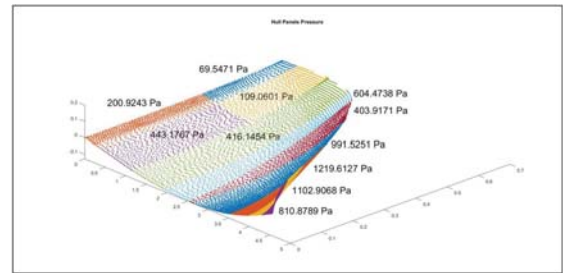

Fig. 4. Hull's Pressures

been obtained, through a simple index system that identifies the corner nodes of each panel. This panelling is the son of a previous work in which the panel partition is based on a criterion provided by regulations. The average of the pressures obtained by CFD has been calculated, as shown in Fig.4 and then applied to the same FEM model panel through a biunique relationship.

### D. Numerical Results

The predictive FE Model integrates the steps previously discussed in an embedded system that takes into account both the loads on the deck, in the form of reaction forces, both the hull's pressure. The results obtained are consistent with the physic's of the problem and suggest that the region subjected to the highest strain field is under the mast foot, as shown in Fig5.

## III. EXPERIMENTAL SETUP

The aim of this work is to validate the structural FEM model of the Polito Sailing Team skiff, in order to do this confirmation, an experimental campaign has been needed, as shown in Fig6 and in Fig7. The experimental setup consists in:

1. Strain acquisition system;
2. Load Cells;
3. GPS, pitch angle, roll angle acquisition system based on Arduino.

The sample frequency chosen for the strain gauges sys-

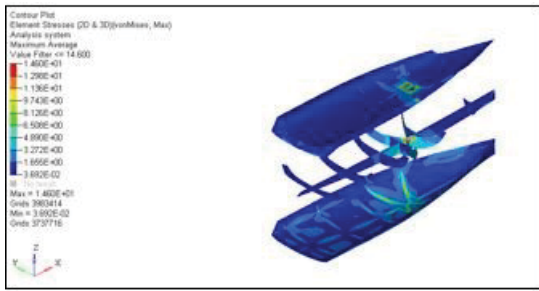

Fig. 5. Strain Field

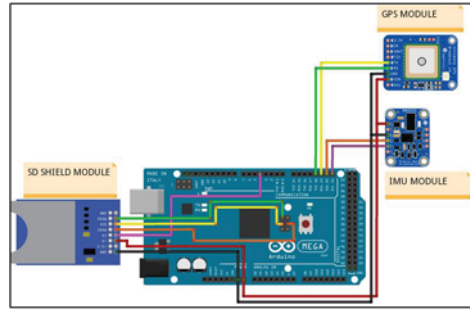

Fig. 7. Arduino acquisition system scheme

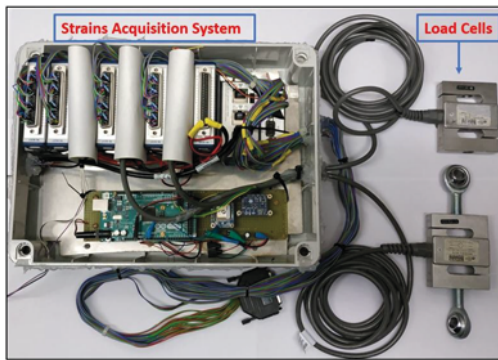

Fig. 6. Acquisition System

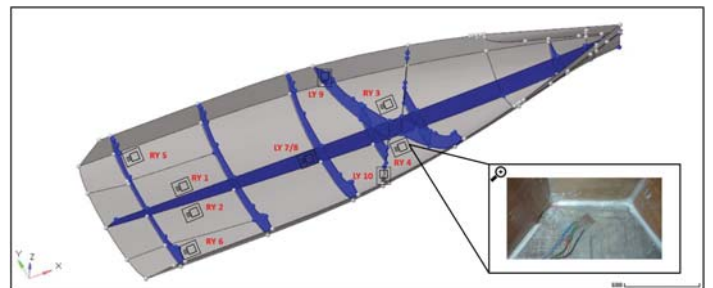

Fig. 8. Strain gauges location

tem si about 100 Hz, this value appears reasonable for static phenomena. Moreover, the saving setup has been designed considering a multiple redundancy in order to avoid a data loss due to failures depending on the adverse environment in which the experiments have been conducted.

In order to obtain the best strain gauge location pattern, a first predictive FEM model has been considered. After this, the whole strains acquisition system is composed by six three-grid rosettes (RY10-3/120) and four linear strain gauges (LY11-6/350) [5]. The link with the acquisition device involves a half-bridge Wheatstone configuration with 0.1% of precision resistors. To understand the strain field of the whole structure in according to with the FE model the best measure points chosen are in the joint between the inner structure and the hull in a specular way, while the linear strain gauges have been set on the inner structure beam in the closeness of the chainplates, as is shown in Fig. 9. Due to the aggressive environment, a way to protect the sensors has been needed the whole sensors located both on the hull both on the inner structure have been treated with a coating composed by a polyurethane skin and a layer of silicon.

#### IV. BOUNDARY CONDITIONS

The environment in which a sail skiff works is affected by countless noises like waves, wind gusts and unintentional bumping by the crew during the maneuvers. This work focuses on ranges in which the dynamic effects are negligible only. In compliance with the assumptions, this work

considers a range about 3 minutes in which the hypotheses have been respected, in particular, the speed range considered is about  $6 \pm 0.5$  ktn as shown in figure.

The whole experimental campaign has been conducted in the lake of Como, in the following, the GPS tracking will be presented, in Fig. 10, with the aim to describe the straight trajectory at most of capabilities of the crew.

#### V. EXPERIMENTAL RESULTS

The results outcome from the acquisition system are consistent with the first predictive FEM model. In particular, the most significant strains gauge and the load cells data are reported in the following figures for the time range considered.

The maximum loads recorded are about 1650 N for the shroud and 1745 N for the chainplates, as is shown in Fig. 11 and in Fig. 12 respectively.

Moreover, the strains time histories, in the range selected will be presented how you can see in Fig. 13 and in Fig. 14.

In order to validate the numerical model, a comparison between experimental results and FEM model has been conducted. In particular, due to the huge numbers of dynamic phenomena involved, the error between Numerical outcomes and Experimental ones has been considered as the difference between the FEM value and the average of the experimental signal. This is possible due to the low values of standard deviation. The results have been reported in Tab.1 and Tab.2.

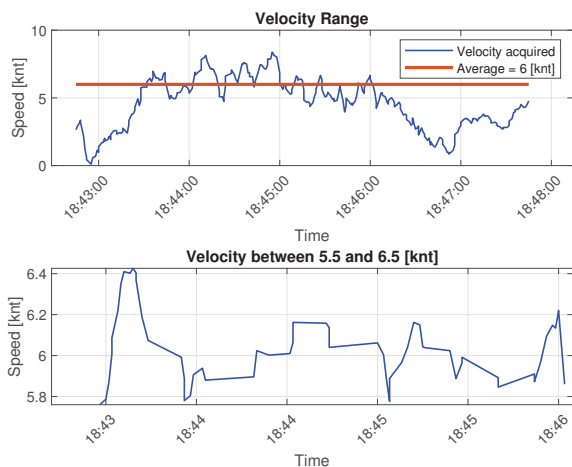

Fig. 9. Velocity Range



Fig. 10. GPS Trajectory

Table 1. Experimental Results

Sensor	Numerical	Experimental	Error	STD
RY 1 45°	$1.61e-05$	$1.22e-05$	14.98%	$8.794e-06$
RY 4 90°	$1.608e-06$	$1.536e-06$	4.48%	$5.201e-07$

Clearly, the discussion about the strain values and the corresponding comparison with to the FEA results deserve a clarification. In fact, the sensors are located in the inner side of the hull, but also at the top layer of the sandwich stratification, in order to compare correctly the equivalent values between experimental data and numerical ones, the composite strain at the top layer has been considered. It has been possible thanks to a reverse assignment of the properties. In this way it is possible to consider each layer individually.

Moreover, a further comparison has been done. In fact, the predictive FE model is characterized by a flexible constrain in order to modelling the interaction with the fluid (sea). An important result is verifying the gap between a flexible model and a rigid one with the experimental results. The results are reported in Tab.2.

Considering the RY 1 45° strain gauge it's impossible to

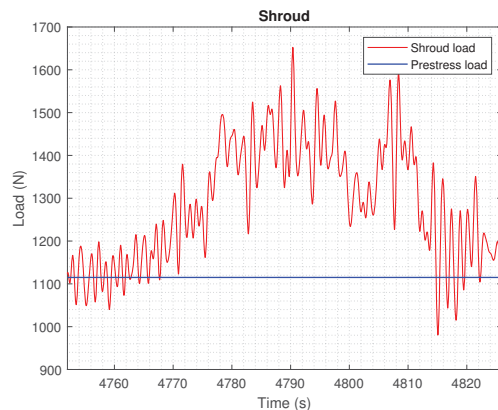

Fig. 11. Shroud load history

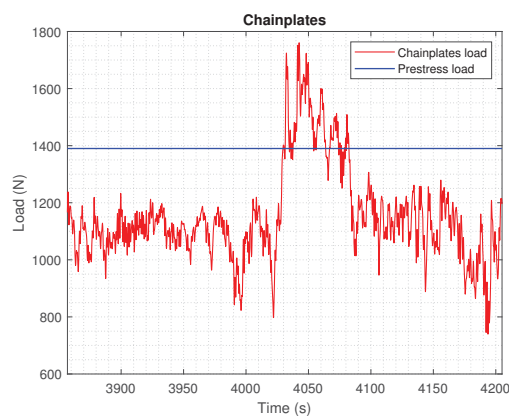

Fig. 12. Chainplates load history

Table 2. Rigid Model Comparison

Sensor	Numerical	Experimental	Error
RY 1 45°	$3.151e-05$	$1.22e-05$	/
RY 4 90°	$9.529e-05$	$1.536e-06$	182%

estimate the error properly, in fact, the sensor is too close to the symmetry constraint and it's affected by it. It is possible to affirm that the flexible model is more reliable than the rigid one.

## VI. CONCLUSION AND FUTURE WORKS

In the end, we can affirm that the FEM model is verified by experimental results. This work represents a first step in the structural design cycle adopted by Polito Sailing Team. Clearly, the future steps will have to involve a VPP (Velocity Prediction Program) model in order to integrate the skiff system with the boundary conditions as much as possible. Further, another aim is obtaining the Tsai-Wu, or Hill, coefficients by experimental benchmarking in order to apply failure criteria in the design process that involves

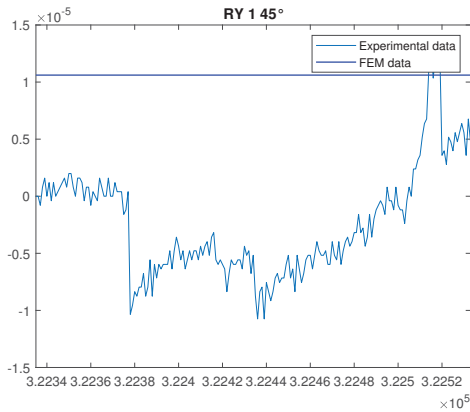

Fig. 13. RY 1 45°

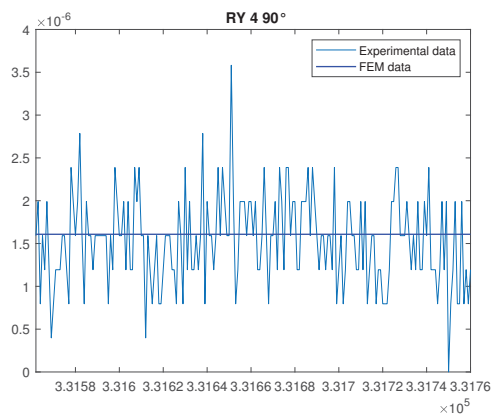

Fig. 14. RY 4 90°

eco-sustainable composite materials.

## VII. ACKNOWLEDGMENT

The authors want to acknowledge all the members of Polito Sailing Team who worked at this project and the facilities of the Department of Mechanical and Aerospace Engineering of Politecnico di Torino.

## REFERENCES

- [1] C. Moscoloni, M. Fontana, B. Passione, M. Cinefra, G. Mattiazzo, "FEM-Aided Structural Design of a Natural Fiber Composite Made Skiff", NAV 2018 19th International conference on ship and maritime research, IOS Press, 2018.
- [2] A. Mancuso, G. Pitarresi, G. B. Trinca, D. Tumino, "Refitting of an eco-friendly sailing yacht: numerical prediction and experimental validation", Lecture Notes in Mechanical Engineering, Springer International Publishing, 2016.
- [3] A. Quarteroni, N. Parolini, "Modelling and numerical simulation for yacht engineering", Proc. of 26th Int. Symp. On Naval Hydrodynamics, 2007.
- [4] C. J. Mitchell, "Rigging loads on the yacht 'New Zealand' and rig design formulae. RINA Transaction, 1993.
- [5] K. Hoffman, "An Introduction to Stress Analysis and Transducer Design using Strain Gauges", HBM Tests and Measurement, 2012.