

Demonstration of structural vibration sensing in a deployed PON infrastructure

Original

Demonstration of structural vibration sensing in a deployed PON infrastructure / Di Luch1, I., Ferrario, M., Boffi, P., RIZZELLI MARTELLA, G., Wang, H., Gaudino, R.. - ELETTRONICO. - (2019), pp. 1-3. (European Conference on Optical Communication Dublino 22 - 26 September 2019) [10.1049/cp.2019.0899].

Availability:

This version is available at: 11583/2831036 since: 2021-03-04T16:06:37Z

Publisher:

OSA The Optical Society

Published

DOI:10.1049/cp.2019.0899

Terms of use:

This article is made available under terms and conditions as specified in the corresponding bibliographic description in the repository

Publisher copyright

Optica Publishing Group (formely OSA) postprint/Author's Accepted Manuscript

“© 2019 Optica Publishing Group. One print or electronic copy may be made for personal use only. Systematic reproduction and distribution, duplication of any material in this paper for a fee or for commercial purposes, or modifications of the content of this paper are prohibited.”

(Article begins on next page)

DEMONSTRATION OF STRUCTURAL VIBRATION SENSING IN A DEPLOYED PON INFRASTRUCTURE

Ilaria Di Luch^{1}, Maddalena Ferrario¹, Pierpaolo Boffi¹,
Giuseppe Rizzelli², Haoyi Wang², Roberto Gaudino²*

¹ Politecnico di Milano, Department of Electronic Information and Bioengineering, via Ponzio 34/5, Milano, Italy

² Politecnico di Torino, Department of Electronics and Telecommunications, Corso Duca degli Abruzzi 24, Torino, Italy

**ilaria.diluch@polimi.it*

Keywords: PON, fiber sensors, structural monitoring

Abstract

We demonstrate the possibility of using a deployed Passive Optical Network (PON) infrastructure for structural vibration monitoring for smart city applications and simultaneously downstream 10Gbit NRZ transmission. The impact of PON trunk fibre backscattering noise on sensing system performance is experimentally assessed.

1 Introduction

Fixed access networks, i.e. the last part of the network toward the final users (i.e. all our houses, offices and campuses) are nowadays undergoing a disruptive revolution: a transition from the old twisted pair toward fiber-based solutions, with a forecast that in 5-years most of the population will be reached by Fiber to the Home (FTTH), at least in urban areas [1]. The capillarity of this growing fiber optic infrastructure opens up the possibility of new applications that can run in parallel to the telecom traffic, providing new added value to fiber optic access networks. This topic has recently drawn particular attention and some field trials have proved the opportunity to use the already deployed fiber as a pervasive sensing network offering a large-scale environmental monitoring system, e.g. to detect structural road failures or the onset of seismic and ground motions [2,3]. Experimental proofs reported in [2,3] made use of complex phase-OTDR sensing technologies to recover distributed vibration patterns along an optical fiber link, even in co-presence with high-speed data transmission. In this paper instead the peculiar architecture of Passive Optical Networks (PONs) is exploited in combination with a simpler interferometric sensing approach, as shown in Fig.1, to achieve a pervasive structural monitoring of buildings and civil infrastructures, using two fibres after the PON splitter. The proposed sensing approach was experimentally

demonstrated on an installed SMF link running in the city of Turin, Italy, with the co-presence of a downstream 10Gbit NRZ transmission.

2. Experimental layout

The goal of the architecture shown in Fig. 1 is to prove the feasibility of using two PON branches, i.e. two fibres after the PON splitter, for sensing purposes, e.g. for monitoring the structural integrity of city buildings. This can be achieved by analysing the dynamic deformations, i.e. vibrations, to which the structure can be subject either continuously or due to critical events. The rationale of this setup can be manifold: 1) verify that the entity of vibrations, for example induced by the proximity to a subway, does not exceed a threshold; 2) identify anomalies or changes with respect to a standard vibration pattern that may indicate the beginning of a structural failure; 3) provide an early warning of the occurrence of earthquake phenomena.

To this purpose, the experimental PON layout shown in Fig. 2, has been arranged. An 11 km SMF fibre deployed in the city of Turin, Italy, by one of the Italian FTTH operators, was used to simultaneously perform vibration monitoring and data transmission. At the transmission side, a 1300/1550 WDM optical coupler was used to combine a narrow optical source at 1550 nm (FWHM 100kHz) used for our sensing purposes, together with a downstream 10Gbit NRZ signal at 1310 nm (modulated using a low-cost, directly modulated DFB laser and emulating a 10G-PON transmission). At the output of the urban deployed fiber, a 1xn passive optical splitter was placed to emulate a PON architecture. Two fibers of the splitter, meant for the sensing application, were terminated with Faraday Rotator Mirrors (FRM) to back-reflect the 1550 nm signal. These two mirrored fibers constitute the sensing and reference arms of a Michelson interferometer [4], where the demodulation of the interferometric signal occurs inside the splitter in a similar

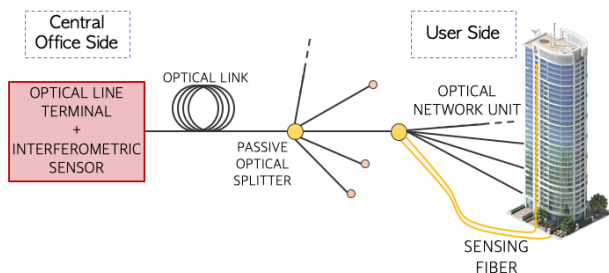

Fig. 1 PON access network architecture where 2 optical ports of the last PON splitter are reserved for building structural monitoring.

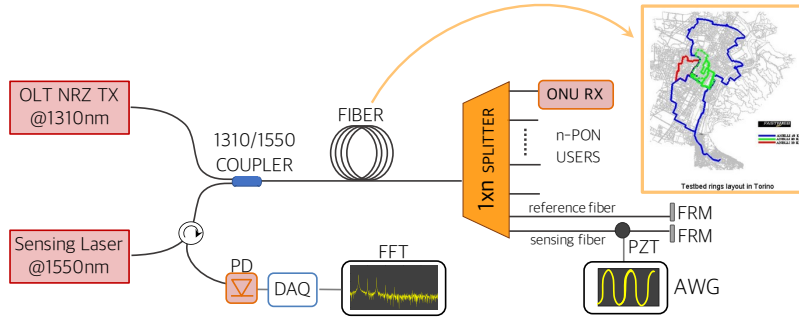

Fig. 2 Experimental PON layout with coexisting vibration sensing system and 10Gbps NRZ transmission.

way to what happens in a 1x2 coupler. FRMs guarantee the retracing of signal polarizations and thus fixed polarizations at the splitter in order to avoid signal fading in interferometric detection schemes [5]. A piezoelectric (PZT) transducer was applied to one of the sensing fibres to induce slow dynamic strain variations in the range of few Hz, to emulate structural vibrations, which, in turn, causes a modulation of the differential phase $\Delta\phi(t)$ accumulated between the two arms of the Michelson interferometer after the PON splitter.

After back-propagating inside the fibre link, the interferometric signal is detected by a 125 MHz photoreceiver ($NEP = 25pW \cdot \sqrt{Hz}$) and sampled by a 50-kS/s (24 bit) data acquisition board. A digital phase-generated carrier (PGC) homodyne technique [6], has been developed in LabView to recover from the measured interferometric signal the differential phase $\Delta\phi(t)$ which is then analysed in the frequency domain.

In parallel, a 10Gbps NRZ signal was transmitted to analyse the coexistence of the data and sensing systems. As shown in Fig. 2, an Optical Network Unit (ONU) was emulated, at the output of which the BER vs. received optical power was measured with and without the potentially interfering sensing signals.

3 Vibration monitoring characterization and experimental results

The proposed PON layout has been assessed for three different splitting ratios, namely, 1x4, 1x8 and 1x16 and for two different fiber links, 11 km and 22 km with respectively 10 dB and 16 dB roundtrip loss. In particular, the phase signal $\Delta\phi(t)$ recovered after the propagation along the city-installed PON link has been evaluated by analysing the received electrical signal-to-noise ratio (SNR) of the first harmonic of a 3-Hz vibration generated by the PZT along a 1.5 meter section of the sensing fiber. This constitutes the dynamic deformation under test in the setup. In particular, a 15nε (nanostrain) dynamic deformation was applied to emulate typical environmental vibrations [3], resulting in a peak-to-peak phase signal $\Delta\phi(t)$ of about 70 mrad, which, typically, can be recovered with high accuracy by the few-μrad resolution DAQ system. Yet, the goal of this work was to assess how the presence of the PON link can impair the final accuracy of the vibration monitoring system. Let's notice that, thanks to the PON layout, the trunk fiber (i.e. the one from the

central office to the splitter) does not introduce any phase noise contribution as the phase modulation $\Delta\phi(t)$ induced by the vibration is immediately converted into amplitude modulation after the splitter. On the other hand, however, the backreflections due to the ONUs and to other backscattering contributions along the link constitute an important source of noise which adds to the interferometric signal, as shown in Fig. 3, for the 1x4 and 1x16 splitters after 11 km. It's clear that, when the level of the backscattering noise becomes comparable with the interferometric signal, the recovery of the final phase $\Delta\phi(t)$, by means of PGC homodyne technique, becomes increasingly less accurate. The SNR of the sensing system has thus been assessed by considering the ratio of the 3Hz spectral amplitude with respect to the spectral noise level evaluated on a 0.1Hz bandwidth (the FFT having been computed in a temporal window $T=10s$). In Fig. 4(a) the sensing system SNR as a function of the 1550-nm input optical power after the 1300/1550 coupler, ranging from -3 dBm to 3 dBm, is shown. Rayleigh backscattering, generated along the trunk fiber by the forward 1550-nm sensing signal, increases linearly with the input power [4] and, as expected, the SNR remains almost constant, for a given splitting ratio. The main penalty results the roundtrip in the splitter which causes the SNR to drop by 6 dB each time the number of the splitter ports is doubled. Measurements carried out on the 11 km PON link proved promising performances for this solution where, for

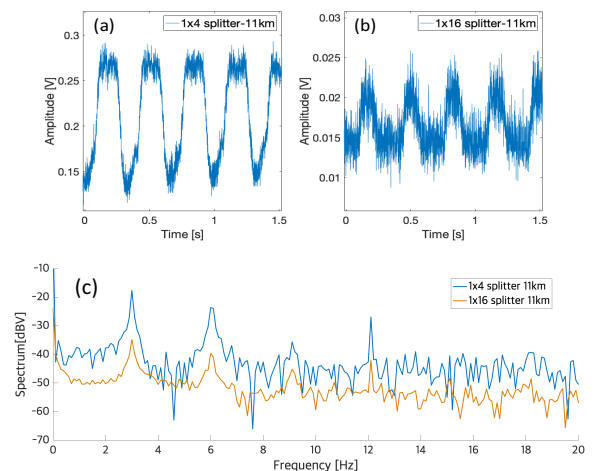

Fig. 3 Received interferometric signals after 11 km for (a) 1x4 and (b) 1x16 splitters and (c) corresponding frequency spectra of recovered phase signal $\Delta\phi(t)$.

example, 26 dB SNR of the 1x4 splitter guarantees a $\pm 5\%$ strain accuracy in vibration detection. With the 1x16 splitter performance worsen, but 15 dB SNR still ensure an acceptable $\pm 17\%$ strain accuracy. The sensing system performance has also been investigated for a 22 km link. To compensate for higher propagation losses, the SNR was evaluated for input power ranging from 0 to 6 dBm. In this case, as input power increases, nonlinear phenomena, such as Brillouin effect, start to set up, reducing the forward signal and at the same time increase the level of in-band backscattering noise, with a consequent reduction of the SNR. This is clearly shown in Fig. 4(b) where, for all the 3 different splitting ratios, the SNR drops when the input power P_I exceeds the Spontaneous Brillouin Scattering (SBS) threshold ($P_I \approx 5$ dBm) [7], leading, for example, for the 1x16 splitter case to a SNR of only 6.5 dB that is unmanageable for monitoring purposes. This aspect thus imposes a further constraint on the overall performance of the proposed sensing solution. Indeed, since the sensing system works with a layout in reflection the overall losses introduced by the PON architecture, i.e. the losses of the roundtrip on the link and the double passage in the splitter are considerable, up to 40 dB for the 1x16 splitter with 22 km. To work with an adequate margin over the receiver's sensitivity it would be necessary to launch higher powers, yet, at the expense of a reduction in the SNR. However, sensing system performance can still be improved by adopting a less coherent laser source or a narrow (8 GHz) optical filter at the receiver side to suppress Brillouin backscattering contribution.

For what concerns the data transmission side of the layout in Fig. 2, both the 1310 nm NRZ signals back-reflected by the two FRM and the backscattering generated by the NRZ signal along the link do not affect the sensing system performance because all these contributions are filtered by the 1300/1550 coupler at the front end.

The impact of the sensing signal on the downstream NRZ 10G received after the 1xn splitter has also been evaluated. Fig. 5 shows the sensitivity curves measured at

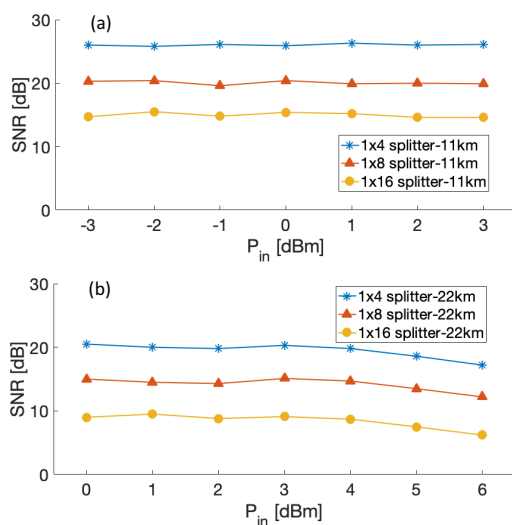

Fig. 4 SNR vs input sensing power P_I for 3 splitting ratios. a) 11 km and b) 22 km PON link.

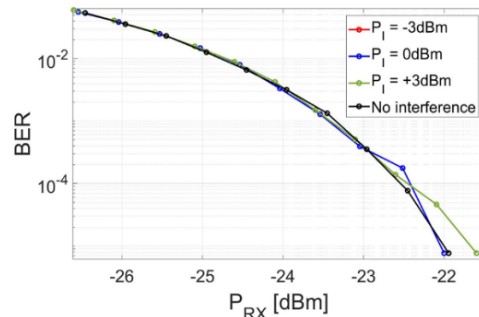

Fig. 5: BER vs. received signal power P_{RX} , after 11km, for different power levels P_I of the interfering sensing signal.

one of the output ports of a 1x8 splitter, after 11km, for different optical power P_I of the interfering sensing signal, compared to the BER obtained in absence of the 1550 nm sensing interference. No significant detrimental effect of the sensing system can be observed on the performance of the implemented PON system, at the considered power levels of the interfering CW sensing signal. Same performance is to be expected also for the 22 km case as the additional 3dB link losses compensate for the higher input power levels P_I .

4 Conclusion

Deployed PON infrastructure are proved to potentially support remote structural vibration monitoring together with 10Gbps NRZ data transmission. System performance has been experimentally assessed showing how PON splitter losses combined to Rayleigh and Brillouin backscattering noise contributions along the link, can impair the final accuracy in dynamic strain measures.

6 References

- [1] Effenberger, F. J., et al.: 'Industrial Trends and Roadmap of Access,' J. of Lightwave. Technology, 2017, 35, (5), pp. 1142-1146
- [2] Glenn, A., et al.: 'First field trial of sensing vehicle speed, density and road conditions by using fiber carrying high speed data,' OFC, 2019, Th4C.7
- [3] Jousset, P., et al.: 'Dynamic strain determination using fibre-optic cables allows imaging of seismological and structural features,' Nature Communications, 2018, 9, article n°: 2509
- [4] Udd, E. and Spillman, W.B.: 'Fiber Optic Sensors: An Introduction for Engineers and Scientists' Wiley, 2011.
- [5] Martinelli, M.: 'A universal compensator for polarization change induced by birefringence on a retracing beam,' Opt. Comm., 1989, 72, pp. 341
- [6] Dandridge, A., et al.: 'Homodyne demodulation scheme for fiber optic sensors using phase generated carrier,' J. of Quantum Elect., 1982, QE-18, pp. 1647-1653
- [7] Yeniay, A., et al.: 'Spontaneous and Stimulated Brillouin Scattering Gain Spectra in Optical Fibers,' J. of Lightwave. Technology, 2002, 20, (8), pp. 1425-1432