

Exploration of power conversion thermodynamic cycles for ARC fusion reactor

*Original*

Exploration of power conversion thermodynamic cycles for ARC fusion reactor / Segantin, S.; Bersano, A.; Falcone, N.; Testoni, R.. - In: FUSION ENGINEERING AND DESIGN. - ISSN 0920-3796. - 155:(2020), p. 111645. [10.1016/j.fusengdes.2020.111645]

*Availability:*

This version is available at: 11583/2826753 since: 2020-05-19T10:35:34Z

*Publisher:*

Elsevier Ltd

*Published*

DOI:10.1016/j.fusengdes.2020.111645

*Terms of use:*

This article is made available under terms and conditions as specified in the corresponding bibliographic description in the repository

*Publisher copyright*

Elsevier postprint/Author's Accepted Manuscript

© 2020. This manuscript version is made available under the CC-BY-NC-ND 4.0 license  
<http://creativecommons.org/licenses/by-nc-nd/4.0/>. The final authenticated version is available online at:  
<http://dx.doi.org/10.1016/j.fusengdes.2020.111645>

(Article begins on next page)

# Exploration of power conversion thermodynamic cycles for ARC fusion reactor

Stefano Segantin, Andrea Bersano, Nicolò Falcone, Raffaella Testoni

## Abstract

In the worldwide energy industry, nuclear fusion could be a breakthrough in the medium-long term. One promising fusion machine under design at Massachusetts Institute of Technology is ARC reactor. It is likely that the first nuclear fusion plants will rely on a traditional thermodynamic cycle for the downstream power energy conversion. In this framework, one of the design aspects is to maximize the thermal efficiency. In the present paper the thermodynamic cycles, which could be adopted in ARC reactor, are explored. Three cycles have been considered: the Rankine, the Brayton and a combined cycle. For the gas adopted in the Brayton and combined cycles, two options have been investigated: supercritical Helium and supercritical CO<sub>2</sub>. A comparison among thermal efficiency and preliminary considerations on component integrity's, plant feasibility and economics of each studied configurations has been discussed to identify the possible best option for ARC reactor. The results show that a regenerative CO<sub>2</sub> Brayton cycle with intercooler and re-heating systems is the most promising one. Such configurations is able to reach a thermodynamic efficiency of up to 0.6.

**Keywords:** ARC, thermodynamic cycles, power conversion, thermodynamic efficiency, balance of plant, nuclear reactors

## Symbols

$c_p$	Fluid specific heat capacity [J/kgK]
$h$	Specific enthalpy [J/kg]
$\dot{m}$	Mass flow rate [kg/s]
$P_{th}$	Reactor thermal power [MW]
$p_1$	Inlet pump/compressor pressure [MPa]
$p_3$	Inlet high pressure turbine pressure [MPa]
$Q$	Volumetric flow rate [m <sup>3</sup> /s]
$s$	Specific entropy [J/kgK]
$T$	Temperature [K]

## Greek symbols

$\beta$	Brayton cycle compression ratio
$\eta_{th}$	Cycle thermodynamic efficiency
$\eta_{max}$	Maximum thermodynamic efficiency achievable
$\eta_{is}$	Turbomachinery isentropic efficiency

## 1. Introduction

In the worldwide industry, nuclear fusion is a potentially clean and abundant energy source. The first nuclear fusion power plants will probably rely on a traditional thermodynamic cycle for the downstream energy conversion [1],[2]. Hence, to maximize the plant's economics, it is necessary to push the thermodynamic efficiency of the plant as high as possible. Indeed, the main nuclear fusion power plant projects [1],[2] will have several complex and expensive components (i.e. vessel, blanket and magnets) that will be damaged by heat, corrosion and neutrons and therefore will need to be replaced during the lifetime operation of the plant [2].

One promising fusion reactor under design at Massachusetts Institute of Technology (MIT) is Affordable Robust Compact (ARC) reactor [2], [3]. The final goal of this project is tracing a new path to a clean, fast and cheap fusion energy connectable to the power grid. Its design is continuously evolving and every new technological idea is suddenly integrated [4]. For these reasons, the study of its viability in power plant mode cannot disregard the optimization of its downstream thermodynamic cycle.

The present work explores the possible power conversion thermodynamic cycles starting from ARC's operational conditions of the current design [2], [3]. The considered cycles are: Rankine, Brayton and combined. The Rankine cycle is largely adopted in conventional and nuclear power plants, in particular using once-through steam generators that allows the steam superheating [5]. Instead, the Brayton cycle is proposed in Very High Temperature Gas Reactors (VHTGR) [4]. For the gas adopted in the Brayton and combined cycles, two options have been considered: Helium (He) and Carbon Dioxide (CO<sub>2</sub>).

Different configurations, with increasing complexity, have been investigated to maximize the thermal efficiency. Preliminary considerations on component integrity's, plant feasibility and economics of each studied configurations has been also discussed, in addition to the maximization of the thermal efficiency, to identify the possible best thermodynamic cycle option for ARC reactor.

## 2. Overview of ARC reactor

ARC reactor is a new tokamak concept design proposed by MIT [2][3]. ARC itself is conceived to be a fusion nuclear science facility and possibly, a pilot power plant.

ARC is based on a magnetically confined super-hot plasma that merges deuterium and tritium nuclei, obtaining a positive energy gain in the process. To do that, it takes advantage of high temperature superconductor magnets, which can achieve higher magnetic fields in higher operating temperatures with respect usual superconducting magnets [2][7]. High temperature superconductors enable a reactor design much smaller than other projects of similar power, such as ARIES-AT and ITER [8][9].

In ARC, the first energy conversion is given by 14.1 MeV neutrons being stopped in the blanket, which is a liquid tank filled with FLiBe ( $2\text{LiF}\text{-BeF}_2$  [10]) molten salt containing the core. In the blanket the neutrons kinetic energy is converted into thermal energy, which is then the heat source of a thermodynamic cycle. A conceptual scheme of ARC reactor and power plant is shown in Figure 1.

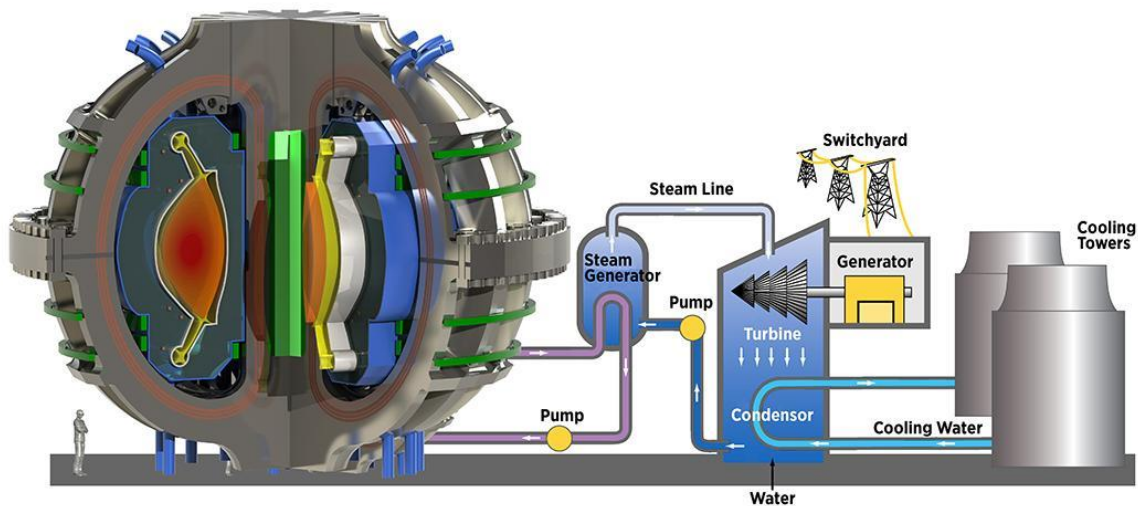

Figure 1 ARC reactor and power plant scheme [11].

From the energy conversion viewpoint, ARC is designed to achieve 525 MW of fusion power [2] and 630 MW of thermal power in the blanket, thanks to exothermic nuclear reactions [3]. ARC's plant thermodynamic efficiency has been estimated to be about 0.4 [2][12] producing 283 MW of electric power and 190 MW of net electric power available for the grid [2]. Three different operating conditions have already been hypothesized for ARC: a Fusion Nuclear Science Facility "FNSF phase", a "Pilot plant phase" and "aggressive Pilot plant phase" [2]. Since the thermodynamic efficiency is directly dependent on cycle's maximum temperature, the three operating conditions are based on the molten salt highest temperature, namely 900 K, 1100 K and 1200 K respectively [2]. However, recent studies on the machine vacuum vessel's integrity suggested not to overcome the blanket's temperature of 880 K for long period of time [12]. It is indeed the vessel the most threatened component of the whole heat transfer system, as turbines and heat exchangers can withstand higher temperatures, comparable to the "aggressive Pilot plant" one [13][14]. Hence, as this study is interested in ARC power plant's efficiency as Pilot plant and also in long-lived ARC based power plants, it is considered FLiBe's maximum temperatures of 1100 K and 1200 K for Pilot plant and aggressive Pilot plant respectively, and also 880 K as actual power plant.

## 3. Methodology

The study analyses two different main thermodynamic cycles: a steam Rankine cycle and a Brayton cycles considering two different fluid options: He and  $\text{CO}_2$ . The Rankine cycle has been assumed with one reheating phase. On the contrary, the Brayton cycle investigation is divided in several stages. The study starts with a

closed simple Brayton cycle and then progressively increases the complexity by applying different optimization techniques. More specifically, stages ordered by increasing complexity are: regeneration (REG), regeneration with intercooler (IC) and reheating (RE) phases, Brayton with a combined Rankine cycle (COMB) and combined cycles with intercooler and reheating, on the Brayton side. Figure 2 displays the rising complexity in Brayton cycles' configurations, which is also the flow of analysis adopted by this work.

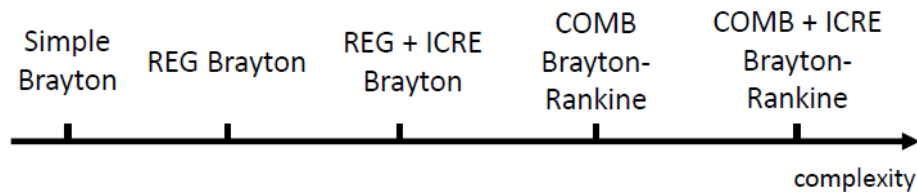

Figure 2 Progressively increasing of complexity in Brayton cycles.

Although it is well known that combined cycles with several compression and expansion stages increase the marginal efficiency, this work begins by the simple Brayton cycle to look for a complexity-efficiency tradeoff. Besides the plant's economics, there is another reason that drives the necessity of a low-complexity power conversion system, namely the likely plant's dynamics: the reactor family to which ARC belongs is likely to have pulsed runs [15], furthermore recent studies are investigating ARC's capability of running in "load-following" mode [4]. The mentioned predictions increase the likelihood of transient regimes in the power plant, which requires for a low-complexity energy conversion system. However, a close analysis of cycle's dynamics is out of the aim of the present study, which instead will address the system complexity and thermodynamic efficiency.

This work adopts an optimizing approach to provide the best cycle choice for ARC and to predict its highest achievable thermodynamic efficiency. Reference temperatures have been assumed as fixed data as they are driven by environmental and technological limits. More specifically, the cycle low temperature, (that is the compressor/pump inlet) has been set equal to 310 K, assuming an environment's room temperature of roughly 293 K and leaving 7 K of temperature increase for the cold fluid in the exchanger and 10 K of pinch hot fluid – cold fluid temperature difference. For the cycle's peak temperature (i.e. turbine inlet temperature) the analysis accounts for three different conditions, as previously mentioned: 870 K, 1090 K and 1190 K, according to the three operating conditions hypothesized in [2][12] and listed in the reactor overview paragraph of this work. In particular they assume 10 K of pinch hot fluid – cold fluid temperature difference at the exchanger and correspond to the FLiBe's peak temperatures of 880 K, 1100 K and 1200 K (i.e. "Inconel vessel's integrity conditions" [12], "Pilot plant phase" and "aggressive Pilot plant phase" [2]), respectively. It should be considered that if ARC will be built in the near future the 880 K is the most probable temperature limit, while 1100 and 1200 K could be considered if more time is dedicated to the development of new and high temperature resistant materials. Nevertheless, ARC needs further R&D in multiple fields to proceed with design and construction, including high temperature materials for fusion. In this regard, it is likely that new materials, such as high entropy alloys [16], for the vacuum vessel will be developed and applied, ultimately allowing higher temperature.

The study takes as input parameters the cycle's main pressures. It computes the efficiency as function of both high and low pressures. Also, intercooler and reheating pressures have been parametrized when the relative systems are considered. In fact, in the most complex case, the analysis handles 4 degrees of freedom, namely the four main pressures. Finally, turbomachinery's isentropic efficiency ( $\eta_{is}$ ) is set equal to 0.9 [17][18]. Moreover, it is assumed that the pressure loss in the heat exchangers is negligible with respect to the pressure variation in the other components.

To manage the huge amount of input data, a Python [19] code has been written, adopting the CoolProp module [20], which provides the thermodynamic properties of several fluids usually employed in heat

exchangers and power conversion systems. Figure 3 shows the main inputs, outputs and possible choices that the code allows to handle.

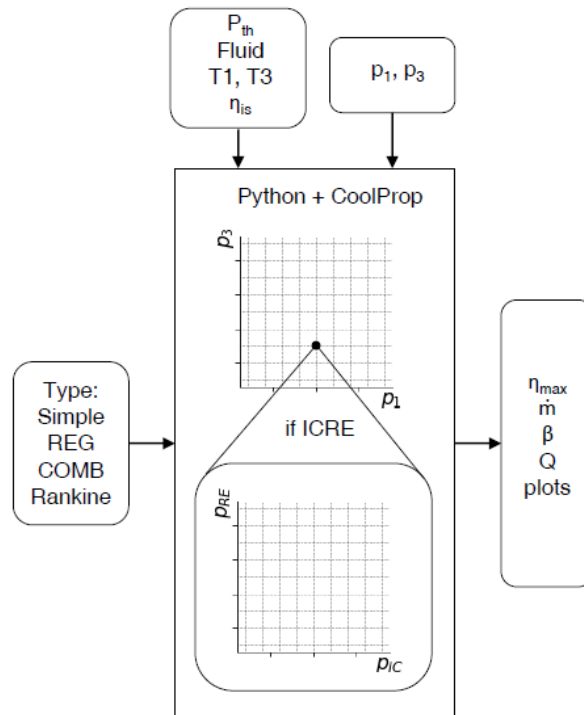

Figure 3 Scheme of the Python program algorithm.

Firstly, the reactor thermal power, type of thermodynamic cycle, fluid type, machine's isentropic efficiencies and main temperatures are entered, then it is possible to input two pressure's arrays. For each couple of pressures, the code builds the thermodynamic cycle and compute main output data like efficiency, power output, and mass flow rate and it also plots the efficiency as function of the two pressures. In the more complex case of Brayton with intercooler and reheating, for each couple of low and high pressures it generates two more vectors of IC and RE pressures that range between the two previously mentioned pressures with the same step, finally computing the same outputs. In this way, each high- and low-pressure point gets the efficiency already optimized to the best IC and RE pressures. This procedure ensures a totally optimized cycle.

### 3.1 The Rankine cycle

The first cycle considered is a Rankine cycle which is largely adopted in conventional and nuclear power plants, in particular using once-through steam generators that allows the steam superheating [5]. The cycle is schematically presented in Figure 4.

Water is evaporated and superheated due to the heat received by the molten salt and then it is expanded in the high-pressure turbine. Then, the fluid is re-superheated in another heat exchanger and expanded in a low-pressure turbine. Finally, the steam is condensed at 310 K and roughly 0.006 MPa and pumped again to the first heat exchanger. Both high- and low-pressure turbine inlet temperatures are set to 870 K, 1090 K and 1190 K for the three reactor's operating conditions. In the Rankine cycle the high pressure ( $p_3$ ) and re-heating pressure ( $p_5$ ) have been taken as main parameters. The first one ranges from 10 MPa to 20 MPa, which stands a little below the critical pressure of 22 MPa, while the latter ranges from 0.5 to 12 MPa, pressure span that identifies the maximum efficiency. In Rankine instance, low pressure ( $p_1$ ) is fixed and set equal to 0.006 MPa as it is the condensation pressure relative to  $T_1 = 310$  K. As specified above, such temperature is the minimum

set in the heat exhaust exchanger for each of the cycles considered here. For simplicity, the computations assume the inlet pump point (1) exactly on the saturated liquid curve. Lastly, the Python program gives the opportunity of checking whether the high- and low-pressure turbine's outlets are actually super-heated steams, as saturated steams could damage the turbine's blades [21].

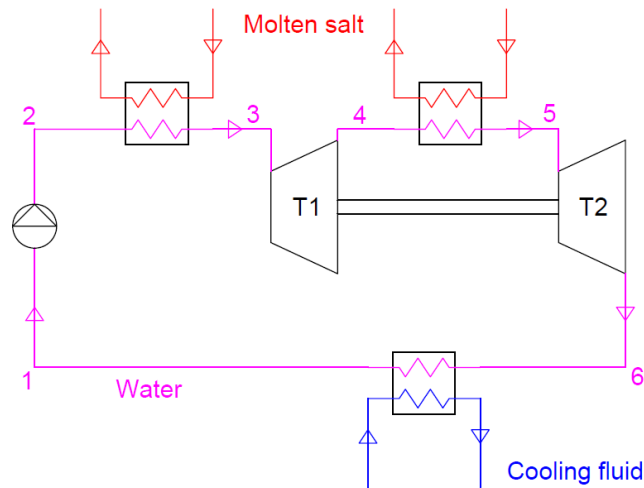

Figure 4 Scheme of the Rankine cycle with re-superheating.

### 3.2 Brayton cycle

The second cycle considered is a closed Brayton cycle. The study starts choosing the most suitable fluids for the foreseen temperatures, which resulted to be He and CO<sub>2</sub> [22][23][24][25]. To increase the total thermodynamic efficiency, several possible plant layouts have been contemplated. Namely, regeneration (REG) and combination with a lower temperature Rankine cycle. Further additional systems such as an intercooler (IC) during the compression stage and re-heating (RE) during the expansion have been evaluated for an additional efficiency increase.

Brayton Helium cycle is supposed to begin the compression (point 1, Figure 5) with a fluid temperature of 310 K, assuming ambient temperature  $\approx$  293 K. Inlet turbine temperature ( $T_3$ ) has been set equal to 870 K, 1090 K and 1190 K, according to assumption listed in paragraph 3 and a hot-cold fluid minimum temperature difference in the heat exchangers of 10 K.

#### 3.2.1 Simple Brayton cycle

The simple closed Brayton cycle (Figure 5) foresees a single compression phase (points 1 to 2), one heat exchanger with the primary loop molten salt (points 2 to 3), one expansion phase (points 3 to 4) and one heat exchanger with an external heat sink (e.g. a cooling tower, a river, etc.) to close the cycle.

The low pressure ( $p_1$ ) and high pressure ( $p_3$ ) have been simultaneously parametrized over a wide range, which was adapted to each fluid. Namely, for helium the range was able to identify the efficiency's peak, starting from a lower pressure slightly above the critical one. While, for CO<sub>2</sub>, it was necessary to identify the pressure parameters in a feasible range. More specifically, the low pressure has its minimum on CO<sub>2</sub> critical point. While, the maximum pressure was set according to state of the art heat exchanger and turbine technologies (25 MPa), addressing, in particular, to their capability of withstand combined thermal and mechanical loads [17][22][26].

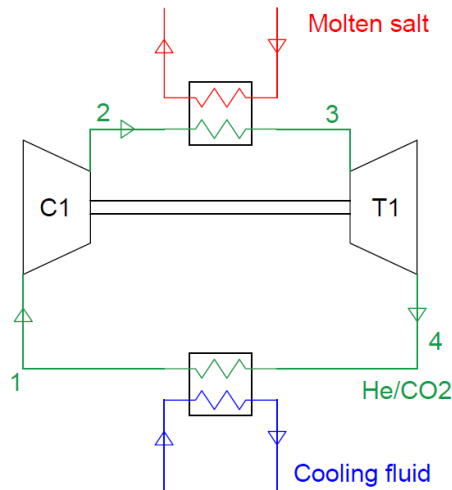

Figure 5 Scheme of the simple Brayton cycle.

### 3.2.2 Brayton with internal regeneration

Results of the simple Brayton cycle (presented afterwards) highlighted, for both helium and CO<sub>2</sub> that the temperature at the turbine outlet (T<sub>4</sub>) was hundreds of Kelvin higher than room temperature and that a large amount of heat was wasted into the heat sink (4-1 isobar transformation). With the implementation of internal regeneration, it is possible to recover most of the heat that would be lost otherwise. Moreover, system's complexity is not significantly increased, being a heat exchanger the only additional component. Also, it could help to mitigate possible thermal shock effects on the pipes since the regenerative heat exchanger preheats the gas before it reaches the high temperature molten salt heat exchanger. In fact, without regeneration, there could be a structural problem as in the exchanger low temperature (T<sub>2</sub>) gas would exchange heat with the high temperature FLiBe. Figure 6 depicts the cycle with the internal regeneration.

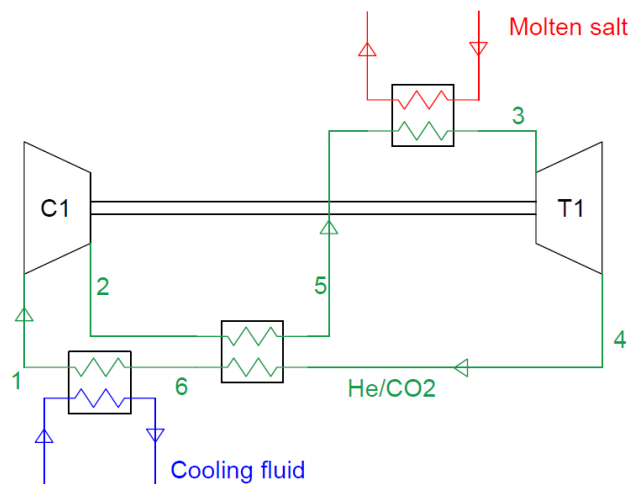

Figure 6 Scheme of the REG Brayton cycle.

From Figure 6 it is possible to notice that the compressed fluid (2) recovers heat from the expanded fluid (4) before receiving the usual heating power from the primary loop (5-3). The additional component is the heat exchanger (2-5/4-6), which reduces the heat removal needed in the heat sink (6-1).

In this configuration a regeneration efficiency (see Equation 1 [27]) of 0.9 has been assumed for the regenerative heat exchanger, as the study aims to work on real cycles. The following equation helps identifying the thermodynamic conditions of point 5, assuming a closed cycle and a fluid with a constant specific heat capacity  $c_p$ .

$$Rs = \frac{T_5 - T_2}{T_4 - T_2}$$

Equation 1

### 3.2.3 Brayton with internal regeneration, intercooler (IC) and re-heating (RE)

An additional improvement for the thermodynamic efficiency is to split both compression and expansion phases. More specifically, the implementation of an intercooler (IC) could help reducing the compression work by preventing the machine to contrast the fluid change in density because of a large temperature increase. A re-heating system (RE) could help increasing the expansion by re-rising the fluid's temperature eventually during the expansion. The intercooling is performed by adding a heat exchanger (IC2-IC1 in Figure 7) between the two compression stages. The re-heating adds another heat exchanger with the molten salt (RE4-RE3 in Figure 7) between the high pressure and low pressure turbines.

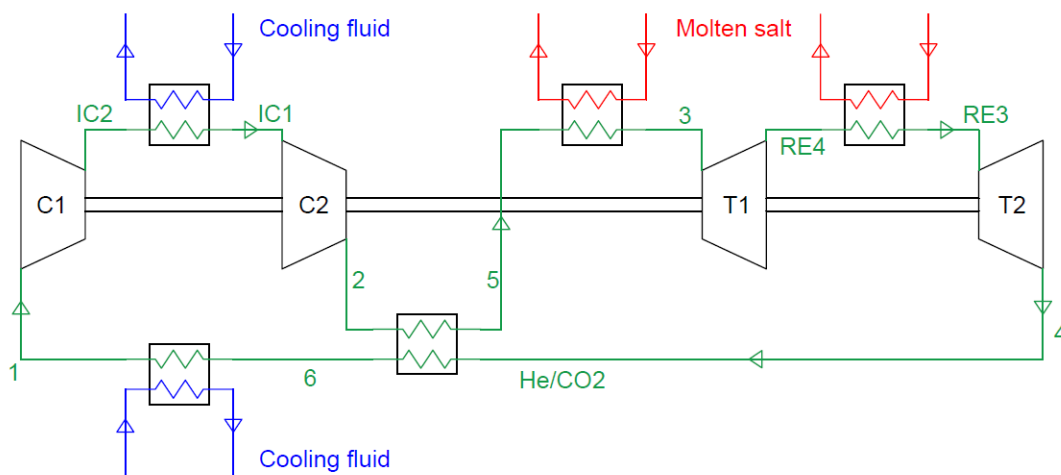

Figure 7 Scheme of the REG-IC-RE Brayton cycle.

Point IC1's temperature ( $T_{IC1}$ ) has been assumed equal to 310 K, like point 1's. RE3's temperature ( $T_{RE3}$ ) was set equal to  $T_3$ , meaning that FLiBe's exchanger splits the flow in the high- and medium-pressure heat exchangers. The medium pressure  $p_{RE3}$  has been varied to get the re-heating optimized and the pressures have been set as additional parameters. To optimize the four pressures at once ( $p_1$ ,  $p_3$ ,  $p_{IC}$  and  $p_{RE}$ ) the Python code picks each couple of  $p_1$  and  $p_3$  of the previous parametrization, and rebuilds the Brayton cycle adding the IC and RE systems. Then, it ranges the intermediate pressures  $p_{IC}$  and  $p_{RE}$  between  $p_1$  and  $p_3$  (see Figure 3). In this way it avoids the risk of picking intermediate pressures out of the range of the  $p_1$ ,  $p_3$  couple and it assures the total optimization of the system as well.

### 3.3 Brayton – Rankine combined cycle

The final option analyzed is a combined Brayton-Rankine cycle. In this configuration, the regenerative heat exchanger is not adopted, while the recovered heat at the turbine outlet is provided as input to a Rankine cycle operating at a lower temperature. The Rankine part of the cycle (shown in Figure 8) is similar to the standalone Rankine cycle option (Figure 4) but the heat is provided by the gas coming from the Brayton instead of the molten salt. Similar assumptions to those adopted for the standalone Rankine cycle have been considered. In particular, the  $T_3$  temperature of the Rankine cycle has been set to be 10 K lower than the upstream Brayton's outlet temperature ( $T_4$ ). However, Brayton's  $T_4$  temperature is dependent on the parametrized pressures. In addition, increasing Brayton's  $T_4$ , the corresponding Brayton's efficiency decreases, but the downstream Rankine's efficiency increases. To consider the total efficiency of the combined cycles, Equation 2 has been applied:

$$\eta'_{tot} = \frac{(\eta'_R \cdot m(h_5 - h_6)_B + (P_t - P_c)_B)}{P_{thARC}} \quad \text{Equation 2}$$

where  $\eta'_{tot}$  is the first attempt global thermodynamic efficiency,  $m \cdot (h_5 - h_6)$  is the heating power exchangeable by the Brayton and the Rankine cycles and  $\eta'_R$  is a first attempt of the downstream Rankine's efficiency, given by Equation 3,  $(P_t - P_c)_B$  is the Brayton's net power output while  $P_{thARC}$  is the total thermal power produced by ARC. Equation 3 describes how the first attempt Rankine efficiency is obtained [28]:

$$\eta'_R = 1 - \sqrt{\frac{T_{ref}}{T_3}} \quad \text{Equation 3}$$

where  $T_{ref}$  is set here as room temperature and  $T_3$  is the Rankine's cycle inlet turbine temperature. The first attempt global efficiency  $\eta'_{tot}$  has been used to design the upstream Brayton cycle. By consequence, the Rankine cycle has been designed and its actual thermal efficiency has been compared to  $\eta'_R$  to confirm or correct  $\eta'_{tot}$ . The verification of the efficiency computed by Equation 3 has been performed with the same code adopted for the standalone Rankine cycle and with similar assumptions. The only difference is the cycle maximum temperature at the turbines inlet ( $T_3$  and  $T_5$ ), which is set accordingly to the results obtained for the Brayton cycle and considering the minimum temperature difference set for the heat exchangers.

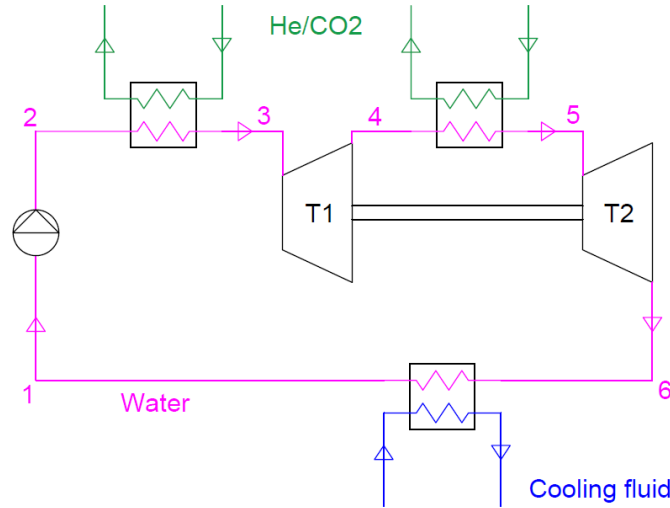

Figure 8 Scheme of the Rankine part of the combined cycle.

The last attempt of efficiency optimization is to add the intercooler and reheating to the Brayton side of the combined cycle (COMB ICRE) that applies an approach analogous to the one explained in subsection 3.2.3 for the regenerative cycle.

### 3.4 Summary of the input assumptions

The assumptions described in the previous sections to fix the input parameters for the various explored layouts are summarized in Table 1. As previously mentioned, temperatures have been chosen to achieve a Carnot efficiency as high as possible. Pressures have been parametrized to identify the efficiency peak while staying in a practical feasible range. Turbomachinery's isentropic efficiencies and regeneration exchanger efficiency have been assumed equal to 0.9.

Table 1 Temperatures and pressures input assumptions.

	$T_1$ [K]	$p_1$ [MPa]	$T_3$ [K]	$p_3$ [MPa]	$T_{1IC}$ [K]	$p_{IC1}$ [MPa]	$T_{RE3}$ [K]	$P_{RE3}$ [MPa]	other
<b>Rankine</b>	310	0.006	870, 1090, 1190	10 - 20	-	-	870, 1090, 1190	0.5 - 12	-
<b>He simple</b>	310	0.3 - 4	870, 1090, 1190	1 - 10	310	-	-	-	-
<b>He REG</b>	310	0.3 - 4	870, 1090, 1190	1 - 10	310	-	-	-	$R_s = 0.9$
<b>He REG IC-RE</b>	310	0.3 - 4	870, 1090, 1190	1 - 10	310	0.3 - 10	870, 1090, 1190	0.3 - 10	$R_s = 0.9$
<b>He COMB</b>	310	0.3 - 4	870, 1090, 1190	1 - 10	310	-	-	-	-
<b>He COMB IC-RE</b>	310	0.3 - 4	870, 1090, 1190	1 - 10	310	0.3 - 10	870, 1090, 1190	0.3 - 10	-
<b>CO<sub>2</sub> simple</b>	310	7.4 - 12	870, 1090, 1190	15 - 25	310	-	-	-	-
<b>CO<sub>2</sub> REG</b>	310	7.4 - 12	870, 1090, 1190	15 - 25	310	-	-	-	$R_s = 0.9$
<b>CO<sub>2</sub> REG IC-RE</b>	310	7.4 - 12	870, 1090, 1190	15 - 25	310	7.4 - 25	870, 1090, 1190	7.4 - 25	$R_s = 0.9$
<b>CO<sub>2</sub> COMB</b>	310	7.4 - 12	870, 1090, 1190	15 - 25	310	-	-	-	-
<b>CO<sub>2</sub> COMB IC-RE</b>	310	7.4 - 12	870, 1090, 1190	15 - 25	310	7.4 - 25	870, 1090, 1190	7.4 - 25	-

#### 4. Results and discussion

In this section, the main results are presented and discussed. The aim of this work is to maximize the thermodynamic efficiency. Therefore, results will mainly focus on this parameter. However, a preliminary analysis on machinery compactness and plant complexity will be discussed to identify the best configuration. To illustrate the outcomes, results and figures in this section are referred to the FLiBe's temperature of 1100 K (corresponding to the "Pilot plant phase") as it is the middle temperature examined. Nevertheless, the cases of 880 K and 1200 K will be discussed in comparison and results sections.

##### 4.1 Rankine cycle

The first cycle considered is the Rankine cycle with a high-pressure and a low-pressure turbine. Figure 9 shows the efficiency of the cycle as function of the maximum pressure and medium pressures; the efficiency raises with the pressure as expected, reaching a maximum of 0.471 at 20 MPa for the 1100 K of FLiBe. Figure 9 shows that re-heating pressure that optimizes the cycle ranges between 1.4 and 3 MPa. Figure 10 depicts the

resulting cycle on the T-s diagram. Two considerations can be drawn. Firstly, the pump's outlet point has a temperature of 321 K, while the lowest temperature allowed for liquid FLiBe is higher than 732 K, therefore the heat exchanger would experience a high temperature gradient (hundreds of K) between the two fluids at the inlet, which will probably raise structural issues during the design. Secondly, the best efficiency point requires the evaporation isobar to stand close to the critical point, suggesting that a supercritical cycle could be more effective for ARC.

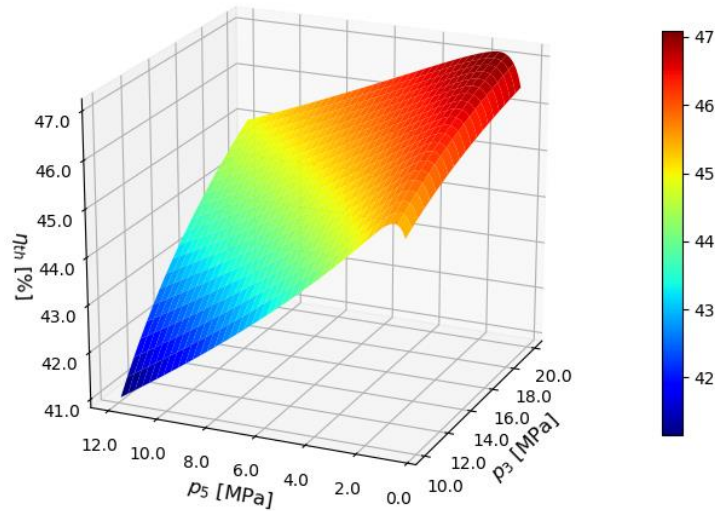

Figure 9 Thermodynamic efficiency of the Rankine cycle.

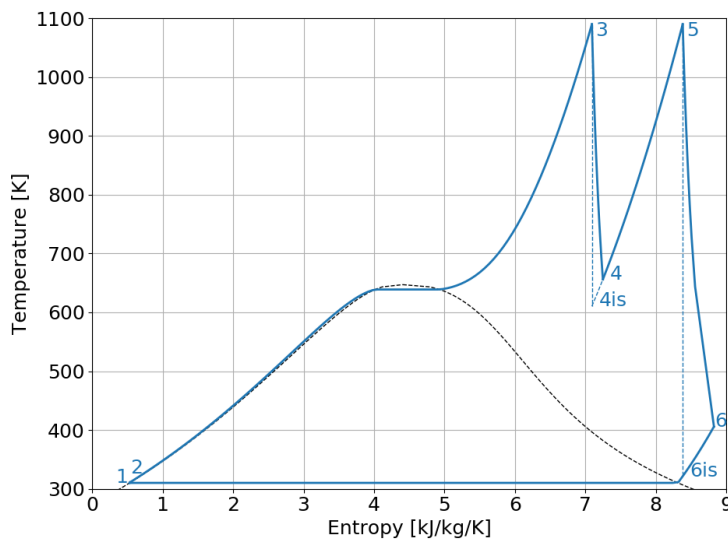

Figure 10 Temperature – Entropy diagram of the actual high efficiency Rankine cycle.

## 4.2 Helium cycle

Although the steam cycle showed fairly interesting results, Brayton cycle is expected to better match ARC's temperatures of operation with respect to Rankine [22]. Helium is the first fluid considered and Figure 11 shows its simplest cycle's efficiency as function of the inlet compressor and inlet turbine pressures.

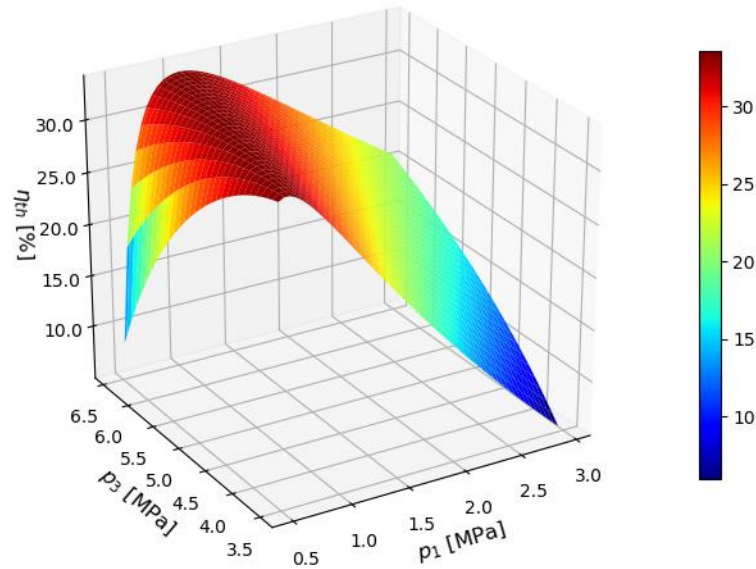

Figure 11 Thermodynamic efficiency of the simple helium cycle.

It is possible to identify the peak at  $p_1 = 0.6$  MPa and  $p_3 = 3.7$  MPa (Brayton compression ratio  $\beta \approx 6.2$ ) corresponding to 0.336 of efficiency. Still, the efficiency's surface shows an almost flat top behavior in a wide range of pressures and  $\beta$ . In this flat area efficiency ranges between 0.320 and 0.336 allowing several solutions for the plant's tuning.

Actually,  $\eta \approx 0.34$  is considered a quite low efficiency, the plant would produce just 200 MW<sub>e</sub>, of which  $\approx 90$  MW are required for sustaining the fusion reaction [2]. Since power plants based on Brayton cycles can usually achieve efficiencies of 0.5 or even more [29], several enhancements should be implemented. In the simple Brayton turbine outlet temperature  $T_4$  ranges between 650 and 550 K. Therefore there is a huge amount of heat that can be recovered, applying technologies such as regeneration or even a combined cycle, as explained in section 3.2.

As regeneration requires just one additional component (heat exchanger) it is the first analyzed. Figure 12 shows results in term of efficiency of a simple helium cycle with a regeneration system.

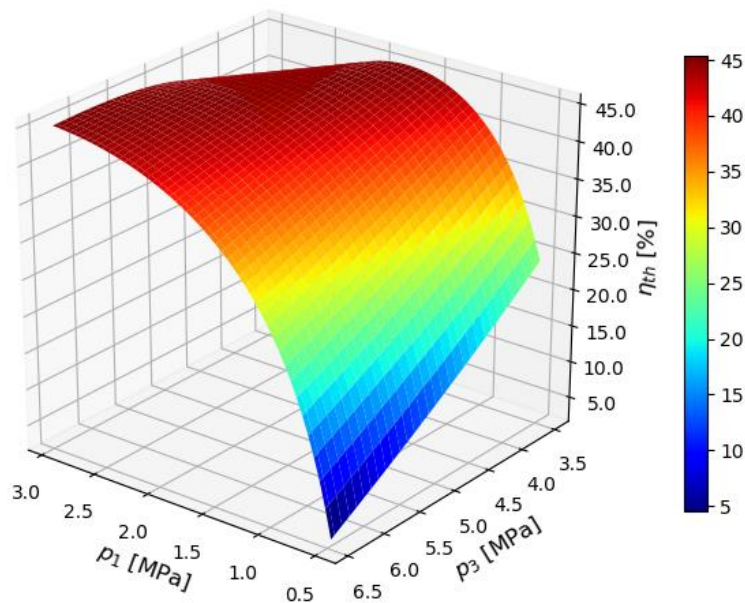

Figure 12 Thermodynamic efficiency of the REG helium cycle.

The heat recovered is able to rise the efficiency by more than 0.1 with respect the previous case, increasing it up to 0.453. In addition, this configuration requires a lower pressure ratio ( $\beta \approx 2.0$  and  $p_1 = 0.6$  MPa) which can be translated to smaller turbomachines, thanks to the lower number of stages required. However, in the next section there will be a deeper analysis on component's compactness.

With the aim of further improving the efficiency, the study evaluates the implementation of both intercooler (IC) and re-heating (RE) stages on the cycle. Recalling section 3.2.3, the script optimizes the IC and RE pressures of each point of the grid, making them range in the entire low-to-high pressure span. Figure 13 shows the results in terms of efficiency as a function of the low pressure  $p_1$  and high pressure  $p_3$ .

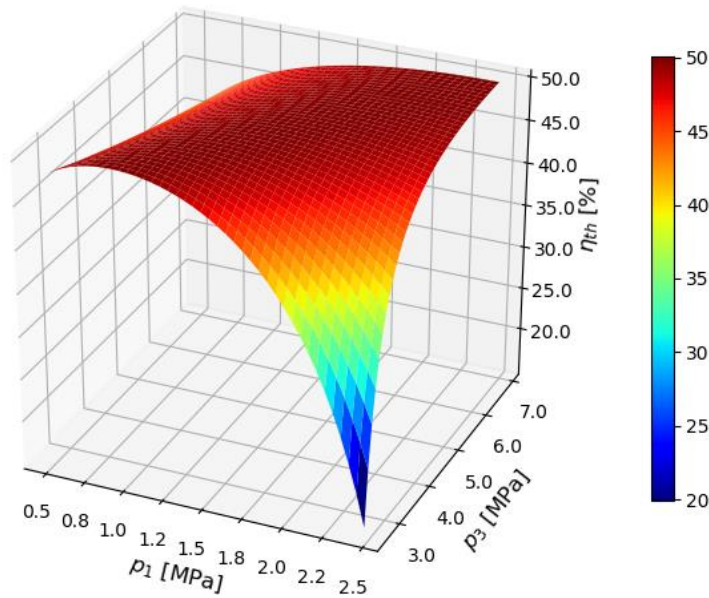

Figure 13 Thermodynamic efficiency of the REG-IC-RE helium cycle.

In this configuration, the efficiency peaks at 0.500, with a gain of almost 0.05 with respect previous cases. In this conditions, the cycle has a low pressure of 0.95 MPa, a high pressure of 2.7 MPa, an IC pressure of 1.5 MPa and RE pressure of 1.8 MPa.

The second technology studied for recovering the heat after the turbine's expansion is a combined Rankine cycle. The methodology applied is described in 3.3, while main results are displayed in Figure 14.

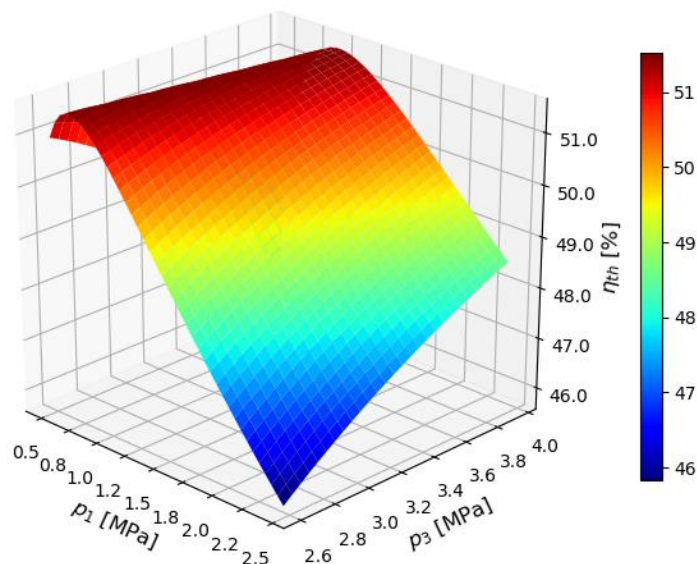

Figure 14 Thermodynamic efficiency of the simple helium cycle with combined Rankine.

The combined cycle achieves efficiencies higher than the regeneration one. A downstream Rankine cycle with an upstream simple Brayton cycle with helium, can potentially achieve efficiencies of 0.515. Implementing the intercooler and re-heating systems it is possible to reach up to 0.563 of efficiency. As anticipated in section 3.3, the combined cycle efficiency has been initially computed with a simplified approach and the results have then been checked with the full model to verify them. The maximum error on the Rankine predicted efficiency was about 0.005 confirming the combined overall efficiencies. Figure 15 shows the T-s diagram of the three helium Brayton cycles analyzed (i.e. simple, simple with regeneration and regeneration with intercooler and reheating). The regeneration allows the diagram to stretch, letting the expansion – compression stages to sensitively increase their differential. Furthermore, similarly to the Rankine cycle, the Brayton simple cycle would have at least 130 K of difference between the cold and hot sides in the heat exchanger’s inlet, leading to likely thermal-structural problems. Regeneration avoids the problem by pre-heating the fluid up to temperature closer to the hot FLiBe ones.

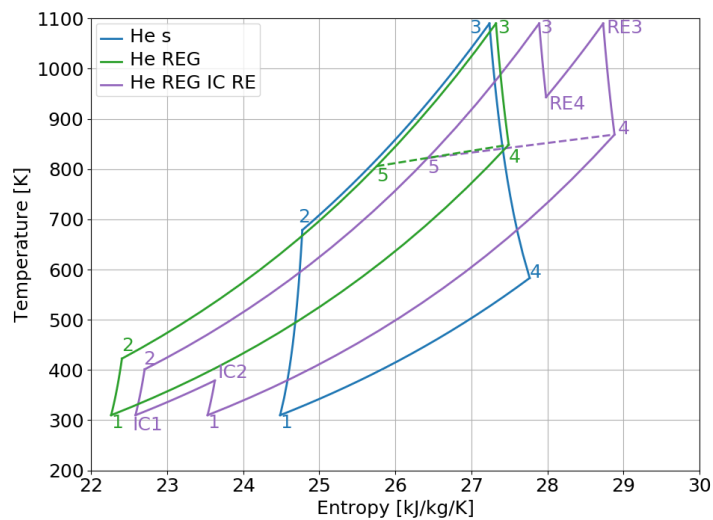

Figure 15 Temperature – Entropy diagram of the helium Brayton cycles in the three studied configuration.

### 4.3 CO<sub>2</sub> cycle

The second fluid analyzed for the Brayton cycle is CO<sub>2</sub>. Unlike helium, it was not possible to find the efficiency peak in the selected pressure range. In fact, efficiency keeps rising way over the pressure range considered and the maximum pressure has been fixed considering technological limits, as previously described. Figure 16 depicts the efficiency evolution as function of inlet compressor and inlet turbine’s pressures, in the case of simple Brayton cycle. The highest efficiency experienced is at high  $p_3$  and low  $p_1$ , namely at high  $\beta$ . Unfortunately, it is not possible to go any lower than  $p_1 = 7.4$ , being it very close to the critical pressure ( $p_{c,CO_2}=7.39$  MPa), nor it is possible to increase the turbine inlet pressure too much, for component’s integrity reasons.

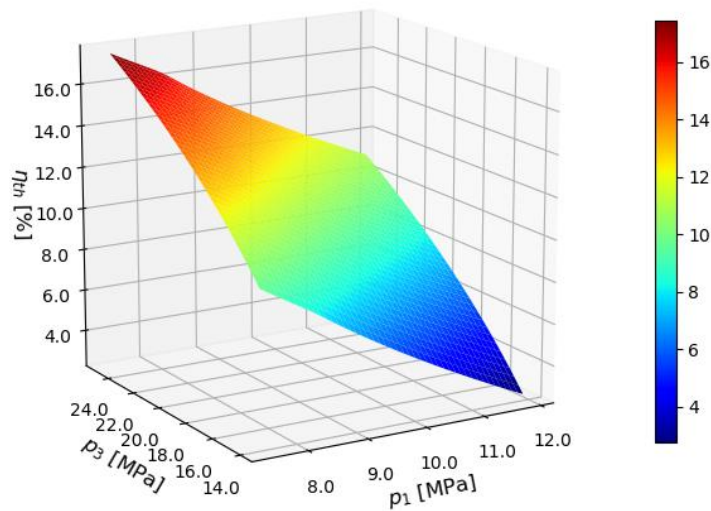

Figure 16 Thermodynamic efficiency of the simple CO<sub>2</sub> cycle.

The maximum  $\eta$  is around 0.175, which is lower than helium's in the corresponding configuration. However, outlet turbine temperatures are in the range of 750 – 850 K, suggesting a huge amount of recoverable heat for regeneration or combined cycles implementation.

Figure 17 shows efficiency's behavior in the simple Brayton with regeneration cycle. It requires a higher inlet turbine's pressures but lower  $\beta$  with respect the simple case. Indeed, the peak efficiency is roughly fixed at  $p_1 = 8.6$  MPa and rises with  $p_3$ .

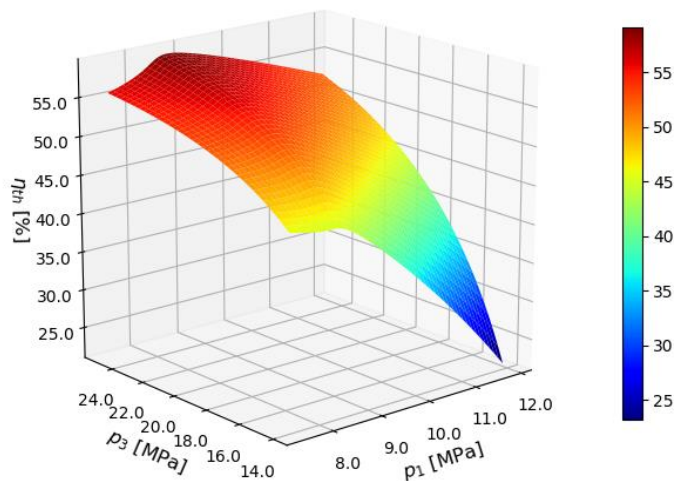

Figure 17 Thermodynamic efficiency of the REG CO<sub>2</sub> cycle.

At low inlet compressor pressure, it differs from the simple cycle efficiency because decreasing  $p_1$  the turbine work increases, which is preferable, especially for the simple cycle, but also the recoverable heat decreases. In other words, decreasing  $p_1$ , the turbine outlet specific enthalpy  $h_4$  decreases, hence  $\Delta h_{\text{turbine}}$  increases. However, with the variation of  $p_1$ ,  $h_1$  rises faster than  $h_4$ 's reduction, strongly decreasing  $\Delta h_{\text{exhaust}}$  and thus the recoverable heat, ultimately causing the efficiency reduction at low  $p_1$  in case of regeneration.

In the regeneration configuration, CO<sub>2</sub> shows the highest efficiencies. Still referring to 1100 K of FLiBe temperature, it touches 0.591 of efficiency. Furthermore, it is possible to marginally increase the gain with the IC and RE systems, as it can be seen below, in Figure 18.

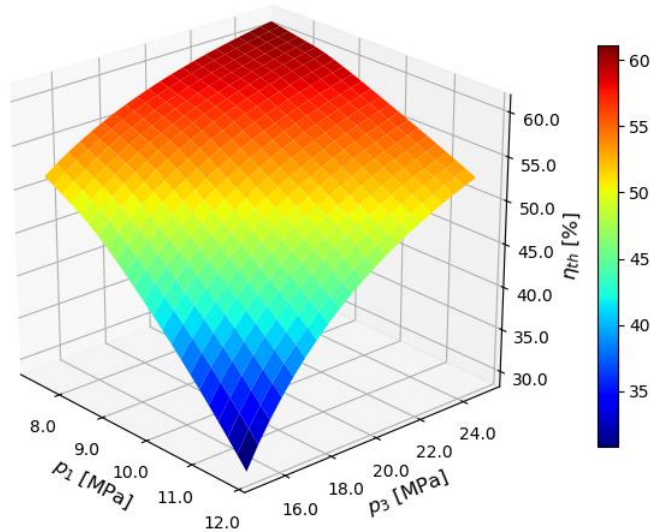

Figure 18 Thermodynamic efficiency of the REG-IC-RE CO<sub>2</sub> cycle.

Considering also the intercooler and reheating, the peak efficiency point goes back to  $p_1 = 7.4$  MPa and  $p_3 = 25$  MPa and increases by  $\approx 0.02$  in all the three FLiBe temperature configurations. However, the cycle complexity would increase with the introduction of two more heat exchangers and more complex turbomachinery. As 0.02 of efficiency corresponds to 10-12 MWe, a comprehensive cost analysis should be carried out to evaluate the implementation of IC and RE systems in such configuration.

The last configuration considered is the combined Brayton-Rankine cycle. CO<sub>2</sub>'s results, predicted by the methodology explained in 3.3, are displayed in Figure 19.

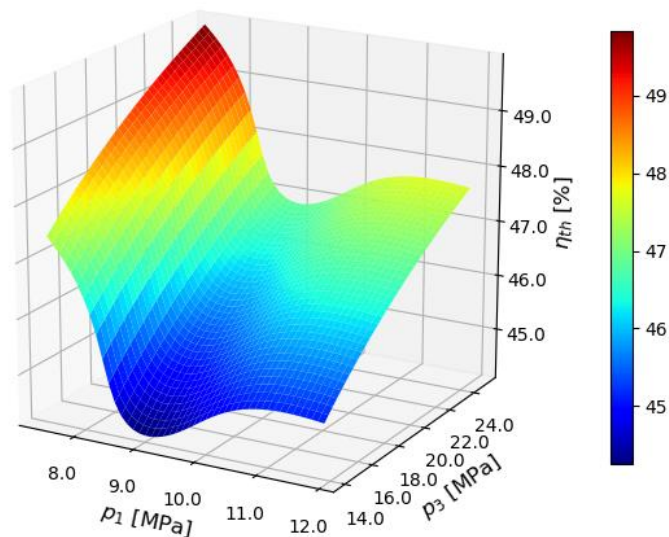

Figure 19 Thermodynamic efficiency of the CO<sub>2</sub> cycle with combined Rankine.

In this configuration there is a peculiar behavior of the efficiency that shows a minimum line in the region of  $p_1 \approx 9$  MPa and it rises both increasing and decreasing  $p_1$ . To explain this, the evolution of the turbine work

and  $T_4$  temperature have been analyzed for different Brayton low-pressures. It results that at low  $p_1$  (i.e. 7.4 MPa) the efficiency increases because the  $\text{CO}_2$  cycle is optimized still leaving a fairly high  $T_4$  for a satisfying downstream Rankine efficiency. On the other hand, at high  $p_1$  the Brayton cycle is not optimized but the turbine's outlet temperature is high enough to increase the Rankine's efficiency. Lastly, in the area of  $p_1 \approx 9$  MPa, thermodynamic conditions do not optimize either of the two cycles. Namely, there is a low enthalpy drop in the Brayton's turbine but the outlet temperature is not high enough to get an optimized Rankine either. In addition, despite the rise of complexity due to an entire additional cycle,  $\text{CO}_2$ 's combined cycles experience a lower efficiency that the corresponding regeneration cycle. In fact, it reaches up to 0.500 of efficiency and 0.523 in the case of combined cycle with IC and RE, as it can be seen in Figure 20. The lower efficiency and high complexity will most likely lead to the decision of adopt a regenerative  $\text{CO}_2$  cycle, rather than a combined one. To complete the analysis, the point at  $p_1 = 7.4$  MPa and  $p_3 = 25$  MPa has been picked to check the actual Rankine efficiency, after having performed the calculation with the simplified approach described in section 3.3. Once again, the maximum error on the downstream Rankine's efficiency was no more than 0.005, confirming the overall efficiency here predicted.

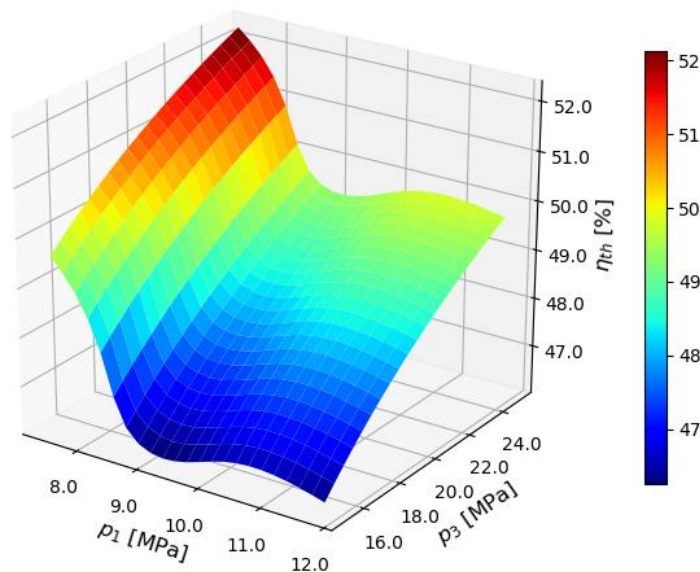

Figure 20 Thermodynamic efficiency of the IC-RE  $\text{CO}_2$  cycle with combined Rankine.

Figure 21 shows T-s diagram of the three  $\text{CO}_2$  Brayton cycles analyzed. In  $\text{CO}_2$ 's instance it is possible to notice how regeneration allows the compression stage to operate on a much lower "work-requiring area", sensitively increasing the efficiency. Moreover, the plot shows that intercooler and re-heating systems would not effectively increase the efficiency. IC is not as effective in pushing the second compression stage to a lower work-requiring region, nor does RE driving the second expansion stage to a higher work-gaining one. Lastly, it is necessary to point out that, similarly to helium cycle, regeneration allows the system to pre-heat the  $\text{CO}_2$  to a temperature comparable to FLiBe's one, letting the exchanger structure to avoid harmful thermal stresses.

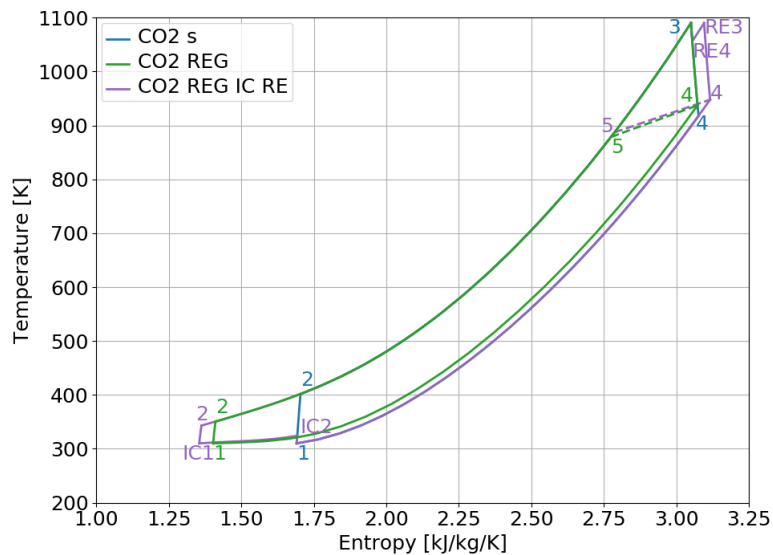

Figure 21 Temperature – Entropy diagram of the CO<sub>2</sub> Brayton cycles in the three studied configurations.

## 5. Comparison of the different options and discussion

In this section the main results are summarized for a better comparison of the various options. Table 2 lists each thermodynamic cycle's peak efficiency for the three temperature cases considered.

Table 2 Comparison of thermodynamic efficiencies for each cycle configuration at the three different FLiBe temperatures considered.

Cycle type	FLiBe peak T [K]		
	880	1100	1200
Rankine	0.426	0.471	0.489
He simple	0.254	0.336	0.365
He REG	0.374	0.454	0.481
He REG IC RE	0.417	0.500	0.529
He Comb	0.431	0.515	0.545
He Comb IC RE	0.478	0.563	0.593
CO <sub>2</sub> simple	0.181	0.175	0.173
CO <sub>2</sub> REG	0.560	0.591	0.597
CO <sub>2</sub> REG IC RE	0.581	0.613	0.620
CO <sub>2</sub> Comb	0.437	0.500	0.521
CO <sub>2</sub> Comb IC RE	0.464	0.523	0.544

REG CO<sub>2</sub> with IC and RE and COMB He with IC and RE show the best efficiencies in any case. Although efficiency can be considered the most relevant parameter in a thermodynamic cycle design, other parameters should be considered. For this reason, Table 3 shows a comparison of the main values that affect different aspects: component's integrity, plant feasibility and economics. Volumetric flow rates, compression ratios and the number of components can be considered direct indices of plant's compactness and economics. Maximum pressures can indicate stress level on heat exchangers and turbomachinery for plant integrity comparisons and possible safety evaluations. Table 3 points out the "number of components" to give an index of the economic cost and complexity of the plant. Nonetheless, it is just a preliminary index and it just considers the main components, such as heat exchangers and turbomachines.

Table 3 Summary and comparison of the different considered configurations' results, case of 1100K of FLiBe's temperature.

	Maximum efficiency	Volumetric flow rate [m <sup>3</sup> /s]	$\beta$	Maximum pressure [MPa]	Number of components	Advantages
<b>Rankine</b>	0.471	3854	-	20.0	6	Simple
<b>He simple</b>	0.336	396	6.17	3.7	4	Simple Low pressure
<b>He REG</b>	0.454	639	2.00	2.4	5	Simple Low pressure
<b>He REG IC RE</b>	0.500	557	2.84	2.7	9	Low pressure
<b>He Comb</b>	0.515	460	3.86	2.7	10	Low pressure
<b>He Comb IC RE</b>	0.563	251	5.80	2.9	14	Low pressure High efficiency
<b>CO<sub>2</sub> simple</b>	0.175	17	3.38	25	4	Simple Compactness
<b>CO<sub>2</sub> REG</b>	0.591	49	2.91	25	5	Simple Compactness High efficiency
<b>CO<sub>2</sub> REG IC RE</b>	0.613	51	3.38	25	9	Compactness High efficiency
<b>CO<sub>2</sub> Comb</b>	0.500	16	3.38	25	10	Compactness
<b>CO<sub>2</sub> Comb IC RE</b>	0.523	16	3.38	25	14	Compactness

Rankine cycle reaches up to 0.426, 0.471 and 0.489 of efficiency for the 870K, 1090K and 1190K of cycle's peak temperature, respectively. Rankine has the lowest efficiencies among all the three cycles and requires relatively high pressures (i.e. 20 MPa) to hit the efficiency peak. 20 MPa is quite close to the critical pressure which causes the cycle not to take much advantage of the latent heat of evaporation. Additionally, an efficiency optimized Rankine cycle requires huge turbines and heat exchangers since steam's volumetric flow rate has been found to get close to 4000 m<sup>3</sup>/s at its maximum. That is more than four times the highest volumetric flow rate of the considered Brayton cycles. Lastly, in view of possible transient operation of the plant, the two-phase flow which occurs in the evaporating and condensing sections may cause some undesired instabilities. It is likely that Rankine will be considered for ARC if its peak temperature gets reduced by several hundreds of K, down to the temperature region where its efficiency overcomes Brayton's one [22]. Brayton helium cycle was the first choice for ARC ever since its first conceptual design [2]. Its efficiency appears to increase with plant's complexity. In the case of 1100K of FLiBe temperature, efficiency goes from 0.336 of the simple cycle to 0.500 of the REG cycle with IC and RE, to 0.563 of the COMB cycle with IC and RE. In the other temperatures the efficiency leap is similar. Even though combined cycle shows a huge enhancement, it does not seem to be particularly suitable for a fusion plant for its higher complexity of having two drop-down thermodynamic cycles and for the same reasons explained in the Rankine instance. In the helium case, intercooler and reheating systems have a non-negligible effect, increasing the efficiency by roughly 0.05, which correspond to roughly 30 MW<sub>e</sub>. Moreover, helium's operational pressure is not far from FLiBe's one (that is 0.2 – 1 MPa), drastically reducing structural issues in the heat exchangers. Helium is supposed to run in the range 0.3 – 6 MPa, depending on design conditions, and there is no necessity of going any further than 10 MPa, in any case. As previously mentioned, in both regenerative and combined cases, helium shows a sort of flat-top efficiency behavior. Despite having found an absolute efficiency maximum in each of the helium configurations, other efficiency points in the flat-top region were lower than the maximum one just by 0.001-0.01. This flat behavior lets the cycle to get tuned according to other plant properties, like compactness. In this work compactness is addressed by two parameters. The compression ratio  $\beta$  is

directly proportional to the turbomachines' number of stages, while the volumetric flow rate  $Q$  is directly proportional to machine and heat exchangers' cross section. For simplicity, this study takes as an example the highest  $Q$  in the cycle, which is the turbine's outlet one. Figure 22 shows the simultaneous behavior of  $\eta$ ,  $\beta$  and  $Q$  normalized to their maximum values. The image takes as example the regenerative case, but the combined case is similar.

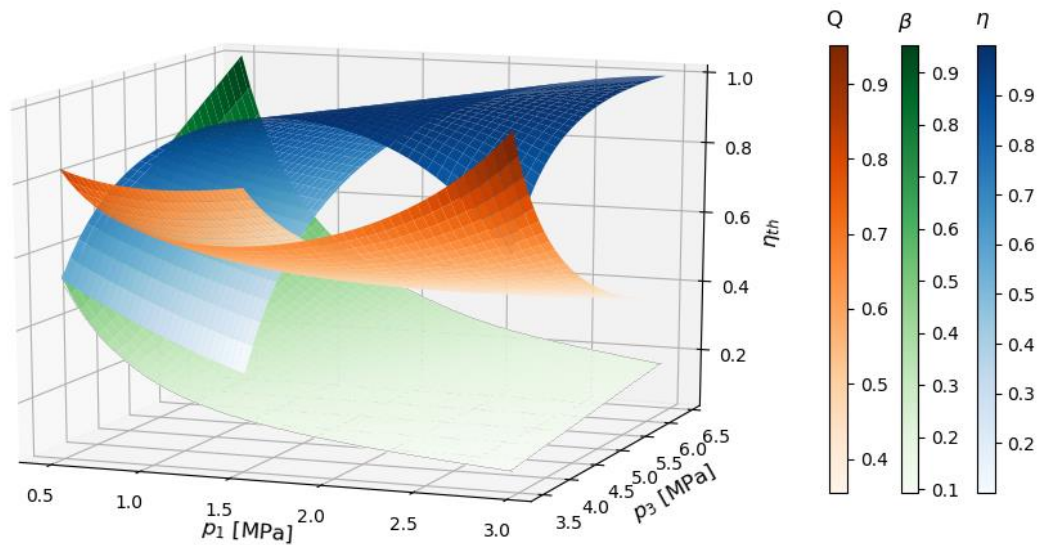

Figure 22 Compression ratio (green), maximum volumetric flow rate (orange) and thermodynamic efficiency (blue) normalized over their maximum for the Brayton cycle.

As it was expected,  $Q$  decrease as the pressures rise, while  $\beta$  decreases where  $p_1$  and  $p_3$  get close to each other. Nonetheless, it is possible to locate a high-efficiency region where the compression ratio is fairly low, and the volumetric flow rate is decreasing (i.e.  $p_1=1-3$  MPa and  $p_3= 4-6$ MPa). In both combined and regenerative instances, the absolute maximum was found in the low  $p_1$  – low  $p_3$  region, where  $\beta$  was quite low but  $Q$  ranges between 900 and 1100  $\text{m}^3/\text{s}$ . In Figure 22, the absolute maximum is at  $p_1=0.75$  MPa,  $\beta=2.0$ ,  $\eta=0.454$ , and  $Q=1021$   $\text{m}^3/\text{s}$ . However, it is possible to adjust the pressures to significantly decrease the volumetric flow rate leaving the efficiency nearly constant. For example, one of the best tradeoffs found is at  $p_1=2.3$  MPa,  $\beta=1.7$ ,  $\eta=0.444$ , and  $Q=418$   $\text{m}^3/\text{s}$ . Even though it loses 0.01 of efficiency it decreases by more than half the machine and exchangers volumes. Considering a very rough assumption of modeling the turbomachine as a cone, where the base's area changes with  $Q$  and the height changes with the compression ratio, this new point virtually decreased the turbomachine volume by a factor of almost 3.

$\text{CO}_2$  Brayton cycle shows the most promising performances by far, in view of both efficiency and compactness aspects. It cannot be considered in the "simple configuration", where its maximum efficiency is lower than 0.2. Its T-s diagram is too compressed and elongated causing the turbine work to be limited and the heat lost after the expansion to be extremely high. The best efficiency values have been recorded with the REG cycle, where they are about 0.58-0.60, with just the addition of a regenerative heat exchanger. The great advantage is that there is no reason to consider a combined cycle, as its efficiency is about 0.05 lower than the regenerative one, despite the additional downstream Rankine. This is also good for the heat exchanger's integrity. With regeneration,  $\text{CO}_2$  gets pre-heated and faces FLiBe when they have similar temperatures, excluding too high temperature gradients in the thin exchanger's pipes. This non negligible thermo-mechanical benefit is available only in the regenerative case. In every other configuration the hot fluid – cold fluid interface could experience a temperature gradient of hundreds of K. Another big advantage of  $\text{CO}_2$  is that it requires extremely compact turbomachines and heat exchangers, thanks to its low  $\beta$  and high density. In the regenerative case, it requires just 51  $\text{m}^3/\text{s}$  of maximum volumetric flow rate and a compression ratio

of 3.4. Such values guarantee components at least four times smaller than the most compact of the helium cycles. A last interesting point that has to be considered is the chance of not including IC and RE systems. As explained above, they raise the efficiency of about 0.02 (10-12 MW<sub>e</sub>), which could need a further analysis on the implementation worthiness. From efficiency's viewpoint, CO<sub>2</sub> best configuration is the regenerative with IC and RE with p<sub>1</sub>=7.4 MPa, p<sub>3</sub>=25 MPa (β=3.4), Q≈50 m<sup>3</sup>/s and efficiencies of 0.581, 0.613 and 0.620, for the three considered temperatures. The second-best configuration is a REG cycle with p<sub>1</sub>=8.7 MPa, p<sub>3</sub>=25 MPa (β=2.9), Q≈50 m<sup>3</sup>/s and efficiencies of 0.560, 0.591 and 0.597 for 880K, 1100K and 1200K of FLiBe temperature, respectively. The main drawback of a CO<sub>2</sub>-based Brayton is the necessity for high pressures. The efficiency peak is well above p<sub>3</sub>= 25 MPa. Despite the clear signs of component feasibility [17][22][26], such pressures require further material development and particularly accurate safety assessments. In this respect, the heat exchanger has been identified as the most endangered component, as it handles the highest temperatures and interfaces a high-pressure gas to a low-pressure and highly corrosive molten salt. Even so, CO<sub>2</sub> predominance over helium is experienced also to lower pressures than 25 MPa. Figure 23 compares peak efficiencies of helium and CO<sub>2</sub>. It is presented a regenerative helium cycle with IC and RE and regenerative CO<sub>2</sub> with single compression and expansion.

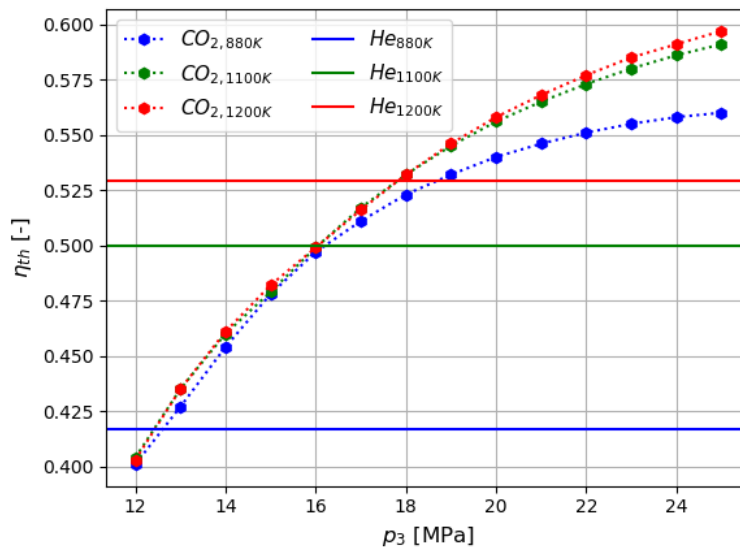

Figure 23 Thermodynamic efficiency as function of high pressure  $p_3$ . For He (continuous lines) and CO<sub>2</sub> (dotted lines). Assuming 880K (blue), 1100K (green) and 1200K (red) of FLiBe temperature.

The figure shows the variation of the efficiency of the CO<sub>2</sub> cycle as function of the turbine inlet pressure for the three FLiBe's temperatures compared to the helium maximum efficiency for the same temperature cases. It can be noticed that for the lower FLiBe temperature (880 K) the minimum CO<sub>2</sub> turbine inlet pressure should be 12.7 MPa to have a higher efficiency than the helium cycle at the same temperature. For 1100 and 1200 K the minimum CO<sub>2</sub> turbine inlet pressure should be 16 and 17.8 MPa respectively.

Lastly, CO<sub>2</sub> cycle has been found to be particularly sensitive to the environment's temperature. A T<sub>1</sub> rise from 310 K to 320K – all other parameters being equal, can cause an efficiency drop of 0.04-0.05. An equal change in T<sub>3</sub> is not that effective, as it decreases the efficiency by about 0.001 – 0.005. Also, Helium and Rankine are not so sensitive to the environment temperature since their efficiency changes by a maximum of 0.01 with a 10K T<sub>1</sub> increment. The instance of CO<sub>2</sub> can be explained by the isobars slope in the region of 307-350 K and critical pressures. As temperature increases in that area, the compressor work rises sharply without any significant variation for the turbine. This behavior causes the need for a careful consideration of the final heat sink type (i.e. sea, river or atmosphere) in the plant localization phase.

## 6. Conclusions

The present work aimed at identifying the best thermodynamic cycle for ARC reactor and to increase its efficiency as high as possible, knowing that previous analysis foreseen it to be around 0.4 [2].

Considering ARC operating conditions, the Rankine cycle resulted to be not the best power conversion option. Rankine could be considered only in particular circumstances (e.g. a lowering of molten salt's maximum temperature, which seems unlikely since FLiBe melts at 730 K). Indeed, Rankine shows relatively low efficiencies, needs large turbines and needs pressures close to the higher-efficiency and more compact CO<sub>2</sub> loop. For similar reasons, in addition to the extreme complexity problem, Brayton-Rankine combined cycles do not seem to be preferable options for ARC, which could operate in daily transient conditions, even though a dynamic study of each cycle should be carried out to identify the most versatile technology. Nevertheless, this path of discarding combined cycles causes the exclusion of helium's most efficient configuration.

Regenerative Brayton cycles appear to be the most promising configuration in term of efficiency, simplicity and compactness. In this respect, an optimized regenerative helium cycle with intercooler and re-heating could achieve 315 MW<sub>e</sub> of power output in the case of 1100 K of FLiBe temperature and 262 MW<sub>e</sub> in the case of 880 K, demonstrating a satisfactory overall efficiency. In addition, it shows a flat-top efficiency behavior, suggesting several solutions in terms of pressures and flow rates for tuning, without significant loss of efficiency. Finally, helium has the lowest pressures of operation by far, there is no necessity of developing any particular strategy for pressure induced stresses mitigation, other than temperature resistance. If the component's integrity will turn out to be a prohibitive aspect of the plant design regenerative helium would be the preferable choice. The drawbacks are the necessity of large components and an efficiency that is lower than CO<sub>2</sub>, which could raise the power output by almost 100 MW<sub>e</sub>. Therefore, a regenerative CO<sub>2</sub> cycle with intercooler and re-heating systems seems to be the best choice for ARC. It could reach 386 MW<sub>e</sub> of power output or, in a more likely scenario – that is at 880 K of FLiBe temperature, 366 MW<sub>e</sub>. Considering also ARC's plasma heating systems to sustain the fusion reaction, the power plant can ultimately provides 280-300 MW<sub>e</sub> of net electric power to the grid. Moreover, CO<sub>2</sub> has the advantage of extremely compact machinery, requiring components more than 4 time smaller than any other fluid considered in this analysis. The disadvantage of this configuration is the high pressure at the turbine inlet (25 MPa). However, it resulted that CO<sub>2</sub> efficiency is higher than helium's also at lower pressures, down to roughly 13-16 MPa where they become comparable, in a still compact plant. In conclusion, the adoption of CO<sub>2</sub> regenerative Brayton cycle appears the best option to be explored for ARC. Clearly, it will require careful material's choice, component's design and plant integrity assessment. However, it could provide almost 300 MW<sub>e</sub> to the grid in an extremely compact and simple plant.

## ACKNOWLEDGEMENTS

The authors would like to acknowledge Professor Massimo Zucchetti from Politecnico di Torino and Professors Zachary Hartwig and Dennis Whyte from the Massachusetts Institute of Technology for the fruitful discussions and for advices.

## References

- [1] Ciattaglia, S., et al. "The European DEMO fusion reactor: Design status and challenges from balance of plant point of view." 2017 IEEE International Conference on Environment and Electrical Engineering and 2017 IEEE Industrial and Commercial Power Systems Europe (EEEIC/I&CPS Europe). IEEE, 2017.
- [2] Sorbom, B. N., et al. "ARC: a compact, high-field, fusion nuclear science facility and demonstration power plant with demountable magnets." *Fusion Engineering and Design* 100 (2015): 378-405.
- [3] Kuang, A. Q., et al. "Conceptual design study for heat exhaust management in the ARC fusion pilot plant." *Fusion Engineering and Design* 137 (2018): 221-242.
- [4] Segantin, S., et al. "The lifetime determination of ARC reactor as a load-following plant in the energy framework." *Energy policy* 126 (2019): 66-75.
- [5] Bersano, A., et al. "Conceptual design of a bayonet tube steam generator with heat transfer enhancement using a helical coiled downcomer." *Progress in Nuclear Energy* 108, (2018): 243-252.

- [6] Bae, S. J., et al. "Preliminary studies of compact Brayton cycle performance for small modular high temperature gas-cooled reactor system." *Annals of Nuclear Energy* 75 (2015): 11-19.
- [7] Hazelton, D. W., and V. Selvamanickam. "SuperPower's YBCO coated high-temperature superconducting (HTS) wire and magnet applications." *Proceedings of the IEEE* 97.11 (2009): 1831-1836.
- [8] Najmabadi, Farrokh, et al. "The ARIES-AT advanced tokamak, advanced technology fusion power plant." *Fusion Engineering and Design* 80.1-4 (2006): 3-23.
- [9] Aymar, R. "The ITER project." *IEEE transactions on plasma science* 25.6 (1997): 1187-1195.
- [10] Serrano-López, R., et al. "Molten salts database for energy applications." *Chemical Engineering and Processing: Process Intensification* 73 (2013): 87-102.
- [11] <http://news.mit.edu/2018/solving-excess-heat-fusion-power-plants-1009>
- [12] Segantin, S., et al. "Exploration of a Fast Pathway to Nuclear Fusion: Thermal Analysis and Cooling Design Considerations for the ARC Reactor." *Fusion Science and Technology* (2019): 1-8.
- [13] Aquaro, d., and M. Pieve. "High temperature heat exchangers for power plants: Performance of advanced metallic recuperators." *Applied Thermal Engineering* 27.2-3 (2007): 389-400.
- [14] Schleicher, R., et al. "An assessment of the Brayton cycle for high performance power plants." *Fusion Technology* 39.2P2 (2001): 823-827.
- [15] Neilson, George, ed. *Magnetic Fusion Energy: From Experiments to Power Plants*. Woodhead Publishing, 2016.
- [16] Xian, Xin, et al. "A high-entropy V35Ti35Fe15Cr10Zr5 alloy with excellent high-temperature strength." *Materials & Design* 121 (2017): 229-236.
- [17] Zhang, Jiangnan, et al. "Design of a Centrifugal Compressor Stage and a Radial-Inflow Turbine Stage for a Supercritical CO2 Recompression Brayton Cycle by Using 3D Inverse Design Method." *ASME Turbo Expo 2017: Turbomachinery Technical Conference and Exposition*. American Society of Mechanical Engineers, 2017.
- [18] Khaljani, M., et al. "Comprehensive analysis of energy, exergy and exergo-economic of cogeneration of heat and power in a combined gas turbine and organic Rankine cycle." *Energy Conversion and Management* 97 (2015): 154-165.
- [19] Python Software Foundation. *Python Language Reference*, version 3.7. Available at <http://www.python.org>
- [20] Bell, Ian H., et al. "Pure and pseudo-pure fluid thermophysical property evaluation and the open-source thermophysical property library CoolProp." *Industrial & engineering chemistry research* 53.6 (2014): 2498-2508.
- [21] Staniša, B., and V. Ivušić. "Erosion behaviour and mechanisms for steam turbine rotor blades." *Wear* 186 (1995): 395-400.
- [22] Ahn, Y., et al. "Review of supercritical CO2 power cycle technology and current status of research and development." *Nuclear Engineering and Technology* 47.6 (2015): 647-661.
- [23] Guriev, O., et al. "S-CO2 represents an advance in power conversion technology." *Turbomachinery International*. The Global Journal of Energy Equipment (2013).
- [24] Chen, Lin-Gen, et al. "Power, power density and efficiency optimization for a closed cycle helium turbine nuclear power plant." *Energy conversion and management* 44.15 (2003): 2393-2401.
- [25] Halimi, Burhanuddin, and Kune Y. Suh. "Computational analysis of supercritical CO2 Brayton cycle power conversion system for fusion reactor." *Energy Conversion and management* 63 (2012): 38-43.
- [26] Carlson, M. D. *Sandia Progress on Advanced Heat Exchangers for SCO2 Brayton Cycles*. No. SAND2014-17501PE. Sandia National Lab.(SNL-NM), Albuquerque, NM (United States), 2014.
- [27] Cali, Michele, and Paolo Gregorio. *Termodinamica*. Società Editrice Esculapio, 1996.
- [28] Leff, Harvey S. "Thermal efficiency at maximum work output: New results for old heat engines." *American Journal of Physics* 55.7 (1987): 602-610.
- [29] Polyzakis, A. L., C. Koroneos, and G. Xydis. "Optimum gas turbine cycle for combined cycle power plant." *Energy conversion and management* 49.4 (2008): 551-563.