

Thermo-economic evaluation of cogeneration plants based on Municipal Solid Waste gasification in the Brazilian scenario

Original

Thermo-economic evaluation of cogeneration plants based on Municipal Solid Waste gasification in the Brazilian scenario / Russo, Sofia; De Oliveira Júnior, Silvio; Desideri, Umberto. - (2018). (ECOS 2018: the 31st International Conference on Efficiency, Cost, Optimization, Simulation and Environmental Impact of Energy Systems, June 17th to 21st 2018 - Guimarães, Portugal Guimaraes, Portugal).

Availability:

This version is available at: 11583/2826632 since: 2020-05-18T20:08:18Z

Publisher:

University of Minho

Published

DOI:

Terms of use:

This article is made available under terms and conditions as specified in the corresponding bibliographic description in the repository

Publisher copyright

(Article begins on next page)

Thermo-economic evaluation of cogeneration plants based on Municipal Solid Waste gasification in the Brazilian scenario

Sofia Russo^a, Silvio de Oliveira Júnior^b, Umberto Desideri^c

^a Polytechnic of Turin, Italy, sofia.russo@polito.it

^b Polytechnic School - University of Sao Paulo, Brazil, soj@usp.br

^c University of Pisa, Italy, umberto.desideri@unipi.it

Abstract:

Municipal Solid Waste (MSW) management is currently a worldwide challenge, which strongly emerges in highly populated countries, where landfilling is still the dominating option. The present work provides an energetic and thermo-economic evaluation of electric and cooling power cogeneration plants based on MSW energy recovery through gasification, in the Brazilian context. After the physical and chemical characterization of the available MSW, a Bubbling Fluidized Bed (BFB) gasifier is modeled and simulated using the software Aspen Plus 8®, in order to estimate the syngas composition. A thermodynamic equilibrium model with a Quasi-Equilibrium Temperature (QET) approach is adopted for simulating the gasification process; a sensitivity analysis is performed to verify the effect of the “steam-to-solid waste” (or “steam-to-feed”, S/F) ratio on Cold Gas Efficiency (CGE) of gasifier, Lower Heating Value (LHV) of syngas and Exergy Efficiency. Syngas energy recovery occurs by combustion coupled with a Rankine steam cycle in a cogeneration plant, which is simulated using a range of representative thermal input according to the per-capita daily MSW generation. The electric power is produced through an extraction-condensation steam turbine, while the low-pressure steam is used in absorption chillers for chilled water production. Finally, a thermo-economic analysis is carried out in order to allocate the cost of the products using exergy-based cost partition criteria. Results show that the medium range of installable power is the more economically convenient, corresponding to thermal inputs between 30 and 150 MW_{th}, being the major costs linked to the gasification section. The high cost of absorption chiller equipment strongly influences the chilled water unit cost, which results almost three times higher than the electricity one.

Keywords:

Thermo-economic analysis, Exergy, Gasification, Municipal Solid Waste, Aspen Plus

1. State of art

1.1. The reference scenario

Municipal Solid Waste (MSW) treatment and management is currently one of the biggest worldwide issue, which is emphasized in developing countries, due to the increase in population and in the adoption of a consumer lifestyle. In Brazil, the total MSW generation in 2014 was approximately 78.6 million tons, representing an increase of 2.9% from the previous year. The growth rate was higher than that of population in the same period, which was 0.9% [1]. Considering a population of 202,799,518 people [2], the per capita year waste generation in 2014 was about 387.63 kg/person/yr. Over 90% of the total amount of produced MSW is collected, which means that over 7 million of wastes have an inadequate final disposal [1]. The implementation of selective collection is recommended by the Federal Law n° 12.305/2010 as a way to achieve the principle of hierarchy in Solid Waste management [3]. However, the most common MSW final disposition is landfill, due to the low cost of this alternative and the large availability of open spaces [4]. Only 58.4% of Brazilian landfills are adequate (sanitary landfills), while the other are uncontrolled landfills or dumps [1]. The fee for the disposal in sanitary landfill varies from 58 R\$/ton to 116 R\$/ton [5]. MSW energy recovery has been proposed as an alternative solution, including thermo-chemical (incineration, gasification, plasma) and biochemical (anaerobic digestion) processes [6-8].

The introduction of MSW for energy production will contribute not only to the enhancement of wastes, but also to the diversification of the Brazilian energy mix, mainly based on hydro-electric power generation [9] and to the energy independence of small municipalities in off-grid regions [10].

1.2. MSW energy recovery through gasification

Gasification is a thermo-chemical process that consists in a partial oxidation of the feed in presence of an oxidant amount lower than that required for the stoichiometric combustion. The result is a synthesis gas, called ‘syngas’, containing large amounts of not completely oxidized products (CO, H₂, CH₄, CO₂, H₂O, N₂, NH₃, H₂S, HCl, tar e char) some of which have a heating value. The gasification agent can be oxygen, oxygen-enriched air or atmospheric air; the latter is generally utilized when the feed is biomass or MSW. The temperature moderator is usually steam; since its presence strongly influences the equilibrium of the reactions and the syngas composition, it is necessary to optimize the steam flow with the feed composition [11]. The main gasification reactions involving steam are reported in Table 1.

Table 1. Main gasification reactions involving steam, adapted from [12]

<i>Gasification reaction involving steam</i>		
$C+H_2O \leftrightarrow CO+H_2$	+131 MJ/kmol	Water-gas reaction
$CO+H_2O \leftrightarrow CO_2+H_2$	- 41 MJ/kmol	Water-gas shift reaction
$CH_4+H_2O \leftrightarrow CO+3H_2$	+206 MJ/kmol	Steam methane reforming

Several commercial technologies are available for gasification plants, but each reactor type can be grouped into one of three categories: moving-bed gasifiers, fluid-bed gasifiers, and entrained-flow gasifiers [11,12]. In case of MSW gasification, Bubbling Fluidized Bed (BFB) presents the following advantages [12-14]: a wide range of feedstock characteristics and size distribution can be used; higher moisture content (up to 55%) is allowed; improved heat exchange; wide range of capacity and moderate capital and maintenance costs. By comparison with the other MSW disposal alternatives, gasification presents environmental and logistic advantages. With respect to landfill option, wastes are reduced in mass (70-80%) and volume (80-90%) [15] and so are CH₄ and CO₂ emissions [16]; besides, since only the organic part is requested for the process, the integration with a selective collection and recycle system is possible. The main advantage of gasification over MSW incineration is the production of an intermediate product (syngas) that is suitable for use in a lot of applications (e.g. fuel and chemicals production, energy recovery). In the case that the syngas is burned, it can be cleaned before the combustion chamber, resulting in smaller gas flow to be processed [11]. This peculiarity, combined with a better combustion control in gas phase, can lead to reduce the emissions, including dioxins and furans [12,17]. The modularity and the possibility of application for small and medium scale are other strengths of gasification [12]. The most used devices for syngas energy recovery are: Steam Turbines (STs) coupled with a traditional boiler; Gas Turbines (GTs); Internal Combustion Engines (ICEs) [12,18]. STs are a proven technology in large scale MSW gasification facilities; since the combustion takes place in a conventional boiler, the required level of syngas cleaning is lower compared to ICEs and GTs, in particular for tars, which are usually higher in case of syngas produced from MSW; besides STs are commercially available in a wide range of size (> 50 kWe), presenting high specific work and life-time, even with moderate electric efficiency (15-24%) [19]. In this work, the choice of STs is also justified by the adoption of steam gasification. A cogeneration asset with chilled water production for refrigerating purposes has been proposed. Absorption Chillers (ACs) have the advantage that the high-temperature source can be steam or waste heat that otherwise would be discharged to the surroundings [20]. ACs are commercially available in two different designs, single-effect and double-effect, depending on the number of condensers and generators [21]. In the present work, steam-driven single effect ACs have been chosen, which are available in size from 60 to 3.300 TR [22]

2. Methodology

2.1. Simulation of syngas production through a BFB gasifier using Aspen Plus 8 ®

Gasification process can be simulated using thermodynamic equilibrium models, kinetic rate models and neural networks models; then, the mathematical model can be implemented through process simulators [23]. Among these, Aspen Plus is a problem-oriented input program that is used to facilitate the calculation of physical, chemical and biological processes [24]. Examples of biomass gasification systems studied with Aspen Plus can be found in literature, using both kinetic [25-26] and thermodynamic equilibrium models [27,28]. Kinetic models provide accurate results in term of syngas composition, but they require knowing the kinetics of all the involved reactions as well as the residence time (or volume reactor). On the other hand, thermodynamic equilibrium models do not require any knowledge of the mechanism of transformation and they are independent from the reactor and not limited to a specific range of operating conditions. Anyway, they could lead to great disagreement under some circumstances [23]. In fact, chemical equilibrium is reached only after an infinite time, in real conditions [11]. It has been observed that at relatively low gasification temperatures (as the ones considered in this work), modeling on the basis of thermodynamic equilibrium lead to the overestimation of H₂ and CO yields of the underestimation of CO₂, methane, tars and char. Anyway, some modification can be made in order to improve the behavior of equilibrium models. An approach is to use a restricted thermodynamic equilibrium model with quasi-equilibrium temperature (QET), which is based on the assumption that some specified reactions reach the equilibrium at temperatures different from the process temperature (e.g. the average bed temperature). This approach was introduced by Gumz [29] and was employed in several works for modeling gasification process, for example [27, 28, 30]. In this work, a thermodynamic equilibrium model with a QET approach has been developed and simulated using Aspen Plus 8 ®. The fact that the simulation is based on an equilibrium model leads to the following assumptions: the reactor is zero-dimensional; heat losses are neglected; perfect mixing and uniform temperature are assumed for the gasifier; tars are not modeled; all equations are at equilibrium.

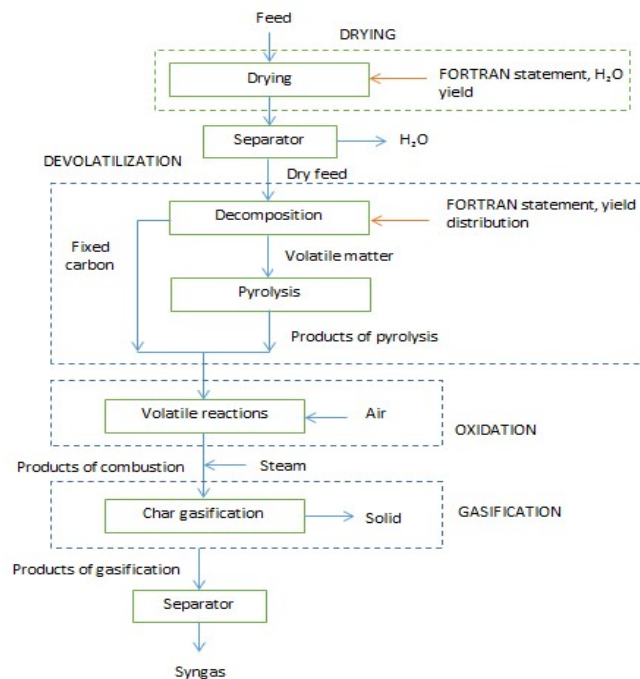

Figure 1 - Gasification flowsheet

In agreement with the literature review [11, 23, 27, 28], other assumptions were made in the model: (i) the process is considered at steady state; (ii) the drying and devolatilization of solid waste are instantaneous; (iii) char is considered to be 100% carbon; (iv) all the volatile matter takes part into the pyrolysis; (v) ideal gases behavior is assumed for gaseous products; (vi) pressure drops are neglected; (vii) ash is considered as inert (viii) all sulfur is present as H₂S while all nitrogen forms NH₃. Gasification process flowsheet used for creating the Aspen Plus block diagram (Appendix A) is presented in Fig. 1. In the Aspen Plus model, solid waste (FEED), dry solid waste (DRYWST) and ash (ASH) are specified as non-conventional components and they are defined using the ultimate and proximate analysis through a FORTRAN statement. C is defined as a solid component. The property method used is RKS-BM, as recommended in [24]. For non-conventional components, HCOALGEN and DCOALIGT are selected as property models for the calculation of respectively enthalpy and density. The selected stream class is MIXCINC, used when both conventional and non-conventional solids are present, with no particle size distribution. The thermodynamic equilibrium model is based on the Gibbs free energy minimization. QET approach has been applied to water-gas shift and steam methane reforming reactions. An empiric methodology for defining the temperature approach (ΔT_{app}) was employed using Aspen Plus tools. Based on experimental data of syngas composition, the percentage contents of some compounds (methane, carbon dioxide and nitrogen) have been fixed at certain values; the corresponding equilibrium temperature for the specified reactions has been found iteratively by the program. The ΔT_{app} found for the steam methane reforming reaction was -246 °C; no definition of ΔT_{app} was necessary for the water-gas shift reaction since there was a good agreement of the calculated results with the experimental data. The results of the simulation with and without ΔT_{app} are reported in Table 2; the experimental composition and operating conditions used for the validation are reported in [31].

Table 2 - Comparison between experimental and simulation results with and without QET approach

	Experimental (%)	Equilibrium model without QET (%)	Difference (%)	Restricted equilibrium with QET (%)	Difference (%)
CO	20.2	25.28	-25.13	22.56	-11.72
CO ₂	11.8	6.5	44.94	10.49	11.11
CH ₄	4.4	0.02	99.64	4.52	-2.92
H ₂	14.7	20.19	-37.38	13.14	10.6
N ₂	49	47.85	2.34	49.27	-0.56

Then the model has been simulated using the gravimetric composition of the Sao Paulo MSW [32] as reference. A degree of separation of 23% is considered, in the assumption of complete separation of plastics, glass and metal, according to [3]. In absence of experimental data, ultimate and proximate analysis has been calculated based on typical values and correlations found in the literature [33]. Results are shown in Table 3. The Lower Heating Value (LHV) is calculated using the Mendeliev Equation, where the values of C, H, O, S are given as mass fraction on wet basis and W is the moisture content; the HHV is estimated with the Sheurer–Kestner equation, with the values expressed on dry basis [34]. The operating conditions to perform the simulation have been chosen based on literature data and technical considerations. Gasification agent is atmospheric air (21% O₂, 79% N₂), pre-heated to 300°C by the syngas exiting the gasifier; the Equivalence Ratio (ER), namely the ratio between the gasification air and the feed, is fixed to 0.35 [23, 27]. Inlet steam conditions are 300°C and 1 bar. Fluidized bed has an average temperature of 800°C [11, 23] at atmospheric pressure, since the syngas has to be burned in a conventional boiler. A sensitivity analysis was conducted varying the steam to feed ratio (S/F) in the range between 0 and 2, by step of 0.1. The effect of S/F on syngas composition and on performance parameters has been analyzed. In order to study the performance of the gasification process, dry syngas LHV (1) and Cold Gas

Efficiency (CGE) (2) of the gasifier have been considered. CO, H₂, CH₄ are the volume percentages of the syngas components on dry basis, syngas flow rate is expressed in Nm³/h and the MSW flow rate in kg/h.

Table 3 - MSW characterization obtained by calculation

Ultimate analysis	Weight percentage (dry basis) %
Carbon (C)	48.73
Hydrogen (H)	6.51
Oxygen (O)	2.00
Nitrogen (N)	37.00
Sulfur (S)	0.33
Ash	5.43
Proximate analysis	
Volatile matter (VM)	82.34
Fixed carbon (FC)	12.23
Ash	5.43
LHV (kJ/kg), wet basis	10145
HHV (kJ/kg), dry basis	20577

$$LHV \left(\frac{MJ}{Nm^3} \right) = \frac{(CO \times 126.36 + H_2 \times 107.98 + CH_4 \times 358.18)}{1000}, \quad (1)$$

$$CGE(\%) = \frac{LHV_{syngas} \times syngas_{flowrate}}{LHV_{MSW} \times MSW_{flowrate}}, \quad (2)$$

In order to perform a qualitative evaluation of the exergy conversion in the gasification process, second law efficiency parameters are utilized. For the purpose of this work, two definitions of exergy efficiency have been chosen (3, 4). The last equation represents the most stringent criterion and it might be called the exergy efficiency of the gasification process [35], since it relates better the function of the gasifier by indicating the increase in exergy of syngas in comparison with the decrease in exergy of the solid fuel.

$$\eta_{ext} = \frac{\dot{B}_{gas}}{\dot{B}_{solid\ waste} + \dot{B}_{air} + \dot{B}_{steam}}, \quad (3)$$

$$\eta_{extII} = \frac{\dot{B}_{gas} - \dot{B}_{air} - \dot{B}_{steam}}{\dot{B}_{solid\ waste}}, \quad (4)$$

The exergy flow rate $\dot{B}(W)$ of each stream material has been calculated as the product between the molar flow rate \dot{n} (kmol/sec) and the sum of the specific chemical \bar{b}_{ch} and physical exergy \bar{b}_{ph} (kJ/kmol). For the last one, the standard environment proposed by Szargut [36] is used; water is considered in liquid state at the reference temperature and pressure. Syngas is considered an ideal mixture of gases, so its chemical exergy is calculated by mean of (5). MSW chemical exergy has been evaluated through (6). For φ values the correlation for solid C, H, O, N compounds with $O/C \leq 2$ is adopted [36].

$$\bar{b}_{ch, prod\ gases} = \sum_i x_i \bar{b}_{ch,i} + RT_0 \sum_i x_i \ln x_i, \quad (5)$$

$$b_{ch, MSW} = \varphi \times LHV_{MSW}, \quad (6)$$

2.2. Cogeneration scenarios

Cogeneration scenarios creation criteria is based on MSW production depending on degree of population. According to [37,38], the total population is divided into fifteen ranges on the number

of people; then, the average population of each subgroup and the corresponding average daily MSW production is calculated using the per-capita value of 1.062 kgMSW/person/day [1]. The available thermal input (MWth) to gasification-cogeneration plant is estimated using the LHV_{MSW} previously calculated. A number of operating hours (HO) of 7800 [5] is assumed for the power plant as well as maximum value of Capacity Utilization Factor (CUF). Seven representative thermal inputs have been chosen in order to reproduce the trend of average available MSW with population, namely: 8 MWth (up to 75,000 people), 13 (125,000), 30 (290,000), 65 (630,000), 95 (900,000), 150 (1,360,000) and 300 (2,590,000). The lowest value is due to the technical limitations coming from the use of steam turbine. Figure 2 represents the scheme of the gasification-cogeneration plant.

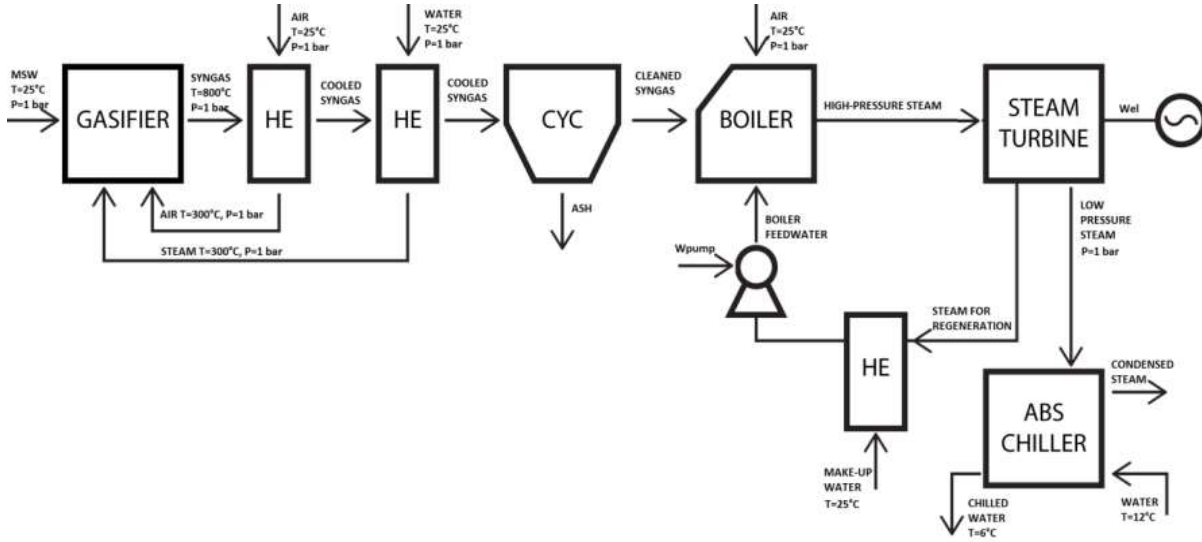

Figure 2 – Gasification-cogeneration plant flowsheet

Syngas combustion takes place at atmospheric pressure, and it is considered adiabatic and performed with atmospheric and not preheated air; NO_x formation and pollutant control system are not modelled. The reference thermodynamic cycle is a regenerative Rankine steam cycle with one steam extraction. An extraction-condensing steam turbine is chosen for the combined production of power and process steam. Besides, the following assumptions have been made: (i) steam is considered 100% water; (ii) all the pumps present in the model are assumed to have an efficiency of 0.7 [38]; (iii) the vapor fraction at the exit of steam turbine has to be higher than 0.8, due to the problems of erosion caused by the condensation of the steam on the turbine blades [39]; (iv) for the flue gas temperature at the exit of the economizer, a lower limit of 130 °C [40] has been fixed, in order to avoid the condensation of sulphur compounds; (v) the efficiency of the electricity generator is fixed at 95%. The operating parameters are varied according to the plant size, in order to reproduce the variation of configuration adopted in commercial plants [12, 39, 41-43], as reported in Table 4.

Table 4 - Variation of operating parameters of power plant, elaborated from [12, 39, 41-43]

Nominal thermal input (MWth)	8	13	30	65	95	150	300
Air to fuel ratio	1.3	1.3	1.25	1.2	1.15	1.1	1.05
Steam pressure (bar)	27	30	35	40	45	65	70
Steam temperature (°C)	300	350	380	400	420	440	450
Mechanical efficiency steam turbine (%)	65	70	73	76	78	81	83
Pressure of bleed-steam (bar)	2.739	3.264	3.388	3.7831	4.174	5.7048	6.972

The Aspen flowsheet of syngas combustion and power production section is shown in Appendix A. The property method used for free-water phase is STEAM-TA, while the calculation of the heat

exchangers is performed using a Shortcut method. Since the aim of the work is to define the maximum heat rate available for cogeneration, all steam is supposed to be extracted at the exit of the second turbine (1 bar) for entering the ACs. Operational parameters of the water-ammonia ACs system are the following [44]: condensation temperature, 40°C; evaporation temperature, 3°C; absorber solution temperature, 60-31°C; generator solution temperature, 56-81 °C; solution concentrations, 58.2-54.2%; chilled water temperature, 6-12°C; COP, 0.7. After the simulation, energy (7) and exergy (8, 9) efficiency parameters have been calculated, for both the entire gasification-cogeneration plant and the cogeneration section only. In the first case the input is represented by MSW, in the second by syngas.

$$\eta_I = \frac{\dot{W}_e + \dot{Q}_{chwat}}{\dot{m}_{input} LHV_{input}}, \quad (7)$$

$$\eta_{bl} = \frac{\dot{W}_{net} + \Delta\dot{B}_{chilwat}}{\dot{B}_{input}}, \quad (8)$$

$$\eta_{bII} = \frac{\dot{W}_{net} + \Delta\dot{B}_{chilwat} - \dot{B}_{feedwat}}{\dot{B}_{input}}, \quad (9)$$

2.2. Thermo-economic analysis

Thermo-economics combines exergy analysis with economic concepts in order to use exergy for allocating costs to the products of a thermal system. The procedure involves assigning to each product the total cost to produce it, namely the cost of fuel and other inputs plus the capital and operation and management costs, considering exergy as a rational basis for assigning cost. [20]. Cost balance (10) has been written for each component of the plant (gasifier, boiler, steam turbine, heat exchangers, pumps, absorption chillers); the exergy unit cost c is expressed in US\$/kWh, the exergy flow rate B in kW and the equipment cost rate C in US\$/s.

$$\sum_{in} c_{in} \dot{B}_{in} + \dot{C}_{eq} = \sum_{out} c_{out} \dot{B}_{out}, \quad (10)$$

The boiler, steam turbine, pump and heat exchanger capital costs (US\$) are approximately estimated by using for every component the exponential form described by Boehm [45] (11), where C_r and S_r are respectively the cost and size of the reference component. The BFB gasifier and ACs costs are calculated by interpolation between data found in the literature [22, 46] according to the plant size. Equipment cost rates are determined by means of (12, 13), under the following assumptions: capital recovery period (N) of 20 years; interest rate (i) of 7.5% per year; operation and maintenance cost equal to 10% of the installation cost, so the $f_{O\&M}$ is 1.1 [5]; 7800 annual operating hours.

$$C_{eq} = C_r \left(\frac{S}{S_r} \right)^\alpha, \quad (11)$$

$$\dot{C}_{eq} = \frac{C_{eq} f_{O\&M} f_a}{3600 \times 7800}, \quad (12)$$

$$f_a = \frac{i}{1 - (1+i)^{-N}}, \quad (13)$$

Feed water and air at atmospheric conditions as well as ash and outlet condensed water are assumed with c_{in} null. The unit cost of MSW c_{MSW} depends on the characteristics of the collection, transport and treatment chain and it is estimated by (14). All costs are calculated on annual basis. The collection and transport cost $c_{C\&T}$ is evaluated according to the average value reported for the municipality of Curitiba [47], corresponding to 41.23 R\$/inh·year (12.91 US\$/inh·year). The primary separation and mechanical treatment costs, c_{SEP} and c_{MTR} , are determined by interpolation of data declared by manufactures [5], depending on the installed capacity. The operational cost

c_{OP} includes the labour cost, in the assumption that each employee is able to carry out the processing of 1 ton of waste during 8 working hours per day [5] and that the minimum salary in Brazil is R\$ 880 (US\$ 256.97). The term c_{WTB} accounts for the incomes derived from the fee (WTB) that the municipalities have to pay for the final disposal; a mean value of US\$ 26.7/ton of MSW is considered [1].

$$c_{MSW} = c_{C\&T} + c_{SEP} + c_{MTR} + c_{OP} - c_{WTB}, \quad (14)$$

The exergy-based cost partition criteria are necessary for the determination of the production costs in multi-products plants. Additional equations to cost balance can be written utilizing one of the following methods: the equality method, in which the analysed equipment must supply all exergy demands and consequently all products have the same exergy average cost ($c_{el} = c_{lpst}$), and the costs are divided among the products as a function of their exergy content; the extraction method, where the equipment has only one function and the product of this function is charged with its capital, operational, and maintenance costs, while the other is not affected ($c_{hps} = c_{lpst}$) [38].

3. Results

3.1. MSW gasification through BFB gasifier

A sensitivity analysis has been conducted varying the S/F ratio between 0 and 2, by step of 0.1. The results were compared with literature data [25,27,28].

3.1.1. Syngas composition

The effect of S/F on syngas composition are shown in Fig.4a, where the volume fraction of CO, CO₂, H₂, CH₄ are plotted on dry, NH₃, H₂S and ash free basis and the N₂ content is not displayed. With increasing S/F, H₂ and CO₂ concentrations increase remarkably, while the CO concentration decreases; CH₄ concentration decreases until approaching zero (for S/F=2, %CH₄=0.18%). The significant variations are in the range 0<S/F<1. Considering the equilibrium nature of the model, an increase in the amount of steam shifts the equilibrium of water-gas, water-gas shift and steam methane reforming reactions towards right according to the Le Chateliers principle; it leads to an increase in H₂ and CO₂ production and CO and CH₄ consumption. This behaviour is also justified under a kinetic point of view [25].

3.1.2. Cold gas efficiency (CGE) and Lower Heating Value (LHV)

Figure 4b shows the effect of S/F on syngas LHV and CGE of the gasifier. LHV decreases with S/F because the increase in H₂ is balanced by the drop in both CO and CH₄. The major drops (10.48%) are in the range 0.2-1.2. The value of CGE does not present significant variations with the amount of steam: it has a minimum at S/F=0.1 and a maximum at S/F=1.2, but the percentage difference between the two points is only of 0.7%. In fact, at low S/F, the syngas LHV is high but its flow rate is small; increasing S/F results in larger amount of H₂O content and syngas flow rate, leading to an increase in CGE even if the syngas LHV is decreasing. Considering the reported LHV and CGE trends and the practical operating data [23], it is recommended to operate the gasifier with values of S/F in the range 0.2-1.2. The choice depends also on the syngas final utilization.

3.1.3. Exergy efficiency

The trend of η_{exI} and η_{exII} as a function of S/F ratio compared to the syngas LHV are reported in Fig.4c. The efficiencies are calculated considering as output the syngas at 800°C and as inputs air and steam at 300°C and solid waste at 25°C. Both the efficiencies increase with S/F with an almost constant growth rate; it can be noticed that η_{exII} is always smaller than η_{exI} , representing a more stringent criterion of evaluation. By increasing S/F the chemical exergy of produced gases $\dot{B}_{ch,gas}$ is lower due to the smaller amount of CH₄ and CO that have the higher values of \bar{b}_{ch} ; however, at the same time the physical exergy $\dot{B}_{ph,gas}$ increases, and the result is an overall increase in the total syngas exergy flow rate. The steam exergy flow rate \dot{B}_{st} also increases with S/F even if with a

lower and decreasing growth rate, so that its contribution is overwhelmed by the syngas increment; this fact might explain the trend of the exergy efficiency.

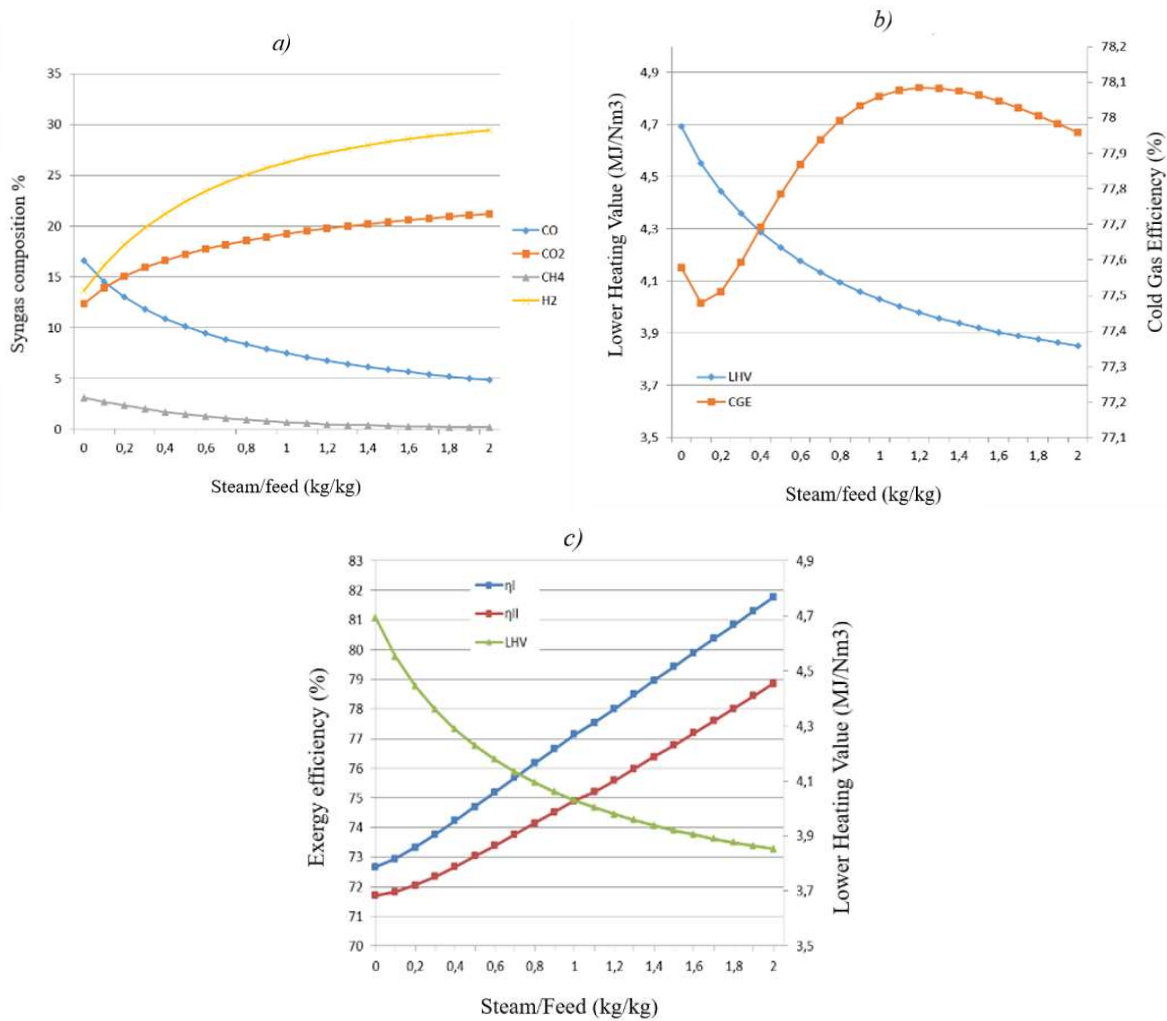

Figure 4 – Effect of steam to feed ratio on a) syngas composition, b) syngas LHV and CGE of gasifier, c) exergy efficiency of gasification

3.2. Cogeneration scenarios

For the simulation, a value of S/F=0.8 has been chosen, since it represents a good trade-off between gasification efficiencies (CGE=77.99%, $\eta_{ExI} = 76.16\%$, $\eta_{ExII} = 74.13\%$) and syngas LHV (LHV=4.094 MJ/Nm³). For both scenarios of power generation and cogeneration, plant efficiencies have been calculated considering as input the syngas and the MSW (overall, 'ov' subscript).

3.2.1. Power generation only

Figure 5a reports the variation of net and gross electric efficiencies $\eta_{e,net}$, $\eta_{e,gross}$ with plant size. The very small percentage difference between them (about 1-2%) is due to the small consumption of the auxiliary. The increasing trend is a consequence of the improvement in operating parameters and turbine efficiency. Anyway, as demonstrated by [43], the improvement of steam parameters has a significant influence on plant efficiency. The values of overall efficiencies are reasonably lower, since the efficiency of the gasification process has to be considered. Figure 5b shows the trend of the exergy efficiencies. The relative small difference between η_{bI} and η_{bII} is due to the small contribution of the inlet exergy flow rate of water in comparison with that of syngas. The range of electricity generation is approximately between 1.2 MWe and 70.6 MWe. Considering the scenarios creation criteria, the potential power generation according to population range is the following:

around 1 MWe from MSW collected from urban centres with a number of inhabitants up to about 75,000; 5-13 MWe for 200,000-750,000 people; 20-34 MWe for 750,000-1,000,000 of people; about 70 MWe for more than 1,000,000 of people.

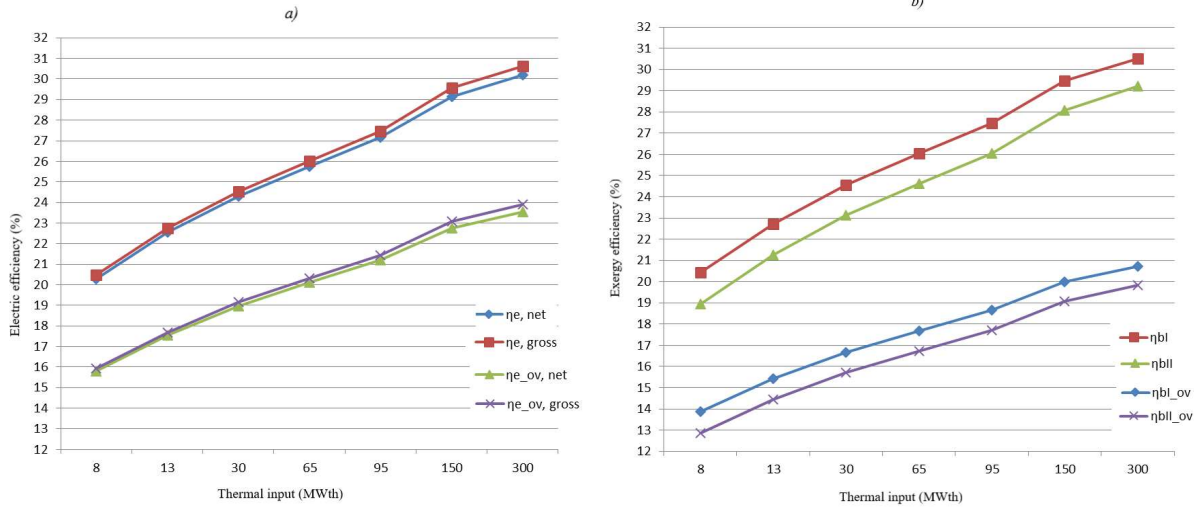

Figure 5 – Electric a) and exergy b) efficiency with thermal input in case of power generation only

3.2.2. Cogeneration

In the cogeneration scenario, the steam is totally extracted in the second turbine, at a pressure of 1 bar. The maximum cooling capacity (CC) of the refrigeration system is reported in Table 5. The results are expressed both in TR (Tons of Refrigeration) and in kW, (1TR=3.516 kW).

Table 5 - Results from the calculation of maximum cogenerated cooling capacity

Nominal thermal input [MWth]	8	13	30	65	95	150	300
CC (kW)	3,450.05	5,447.4	12,337.9	26,382.85	38,379	60,085.2	120,097.5
CC (TR)	981.24	1,549.3	3,509.07	7,503.6	10,915.5	17,089	34,157.4

Figure 6a shows the variation of the first law efficiencies η_I and η_{Iov} with the plant size, while the trend of η_{bI} and η_{bII} is shown in Fig. 6b. It can be noticed that the cogeneration scenario has η_I values about three times higher than the power production only, thanks to the energy recovery from generated steam in ACs system. On the other hand η_b has values about 20% lower; in fact, the reduction in the produced power is not compensated by a high valuable form of energy, since the chilled water has not comparable exergy content.

3.3. Thermo-economic analysis

MSW unit cost decreases with plant size. The major contribution to cost formation is due to $c_{C\&T}$ (61%) followed by c_{SEP} and c_{MTR} (38%) while c_{OP} has the lower influence (1%); the WTB incomes compensates about 37% of the costs. The WTB incomes and labour cost have fixed values, which do not depend on the installed capacity. Gasification equipment has the higher cost \hat{C} , followed in order by ACs, boiler, heat exchanger, steam turbine and pumps. As regard to the products, syngas unit cost has a general increasing trend, except for a first decrement. The electricity and chilled water cost shows a general decrement with an increase of plant size; a new growth is present for great capacity, due to the higher installation costs. Even with the same trend, different values are found using the equality (Fig. 7a) and extraction (Fig. 7b) method. The equality method electricity costs are lower than the extraction method ones, showing a percentage difference from 32% to 14%, increasing the plant size. On the other hand, the equality method chilled water costs are higher than those found by extraction method, with a difference ranging from 31% to 24%.

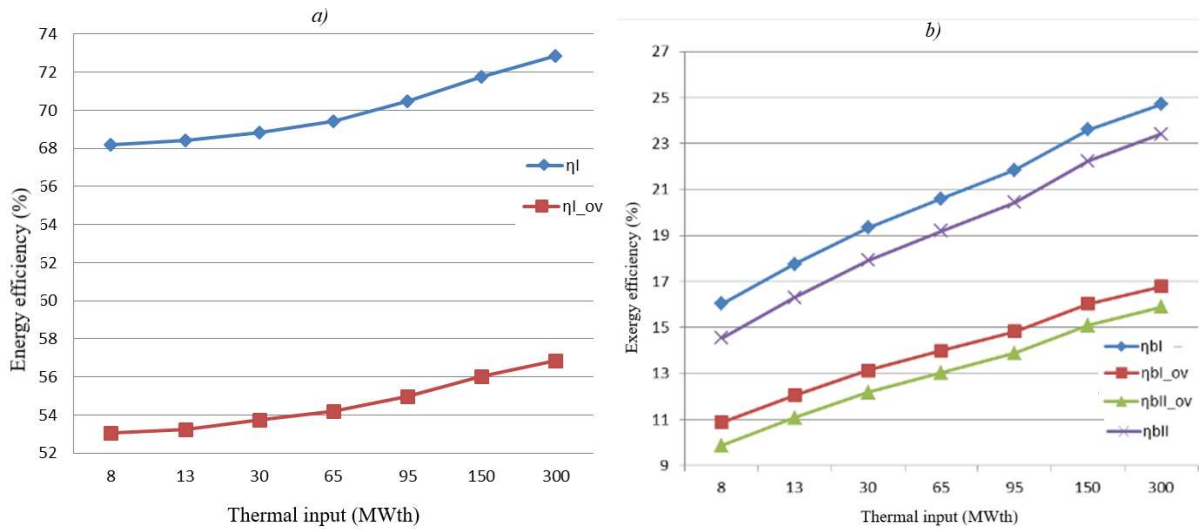

Figure 6 – Energy a) and exergy b) efficiency with thermal input in case of cogeneration

It can be interesting to analyse the ratio (kJ/kJ) between the exergy based cost of products (electricity and chilled water) and raw material (MSW). The trend is shown in Fig. 8a-b, according to the two methods of calculation. For both products, the ratio decreases with plant size reaching the minimum value for thermal input of 30 MWth, and then growing again. The chilled water cost results about 4.5 times higher than the electricity cost, with both methods; it is justified by the high absorption chiller equipment cost.

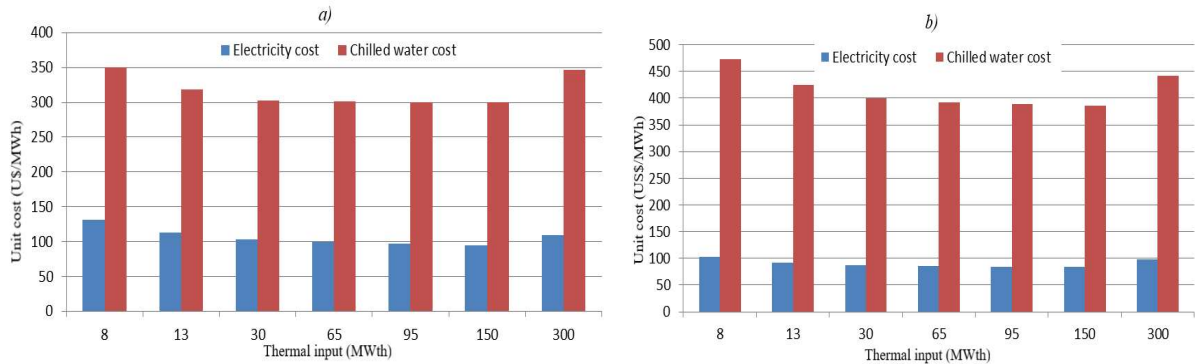

Figure 7 – Products unit costs found with equality a) and extraction b) method

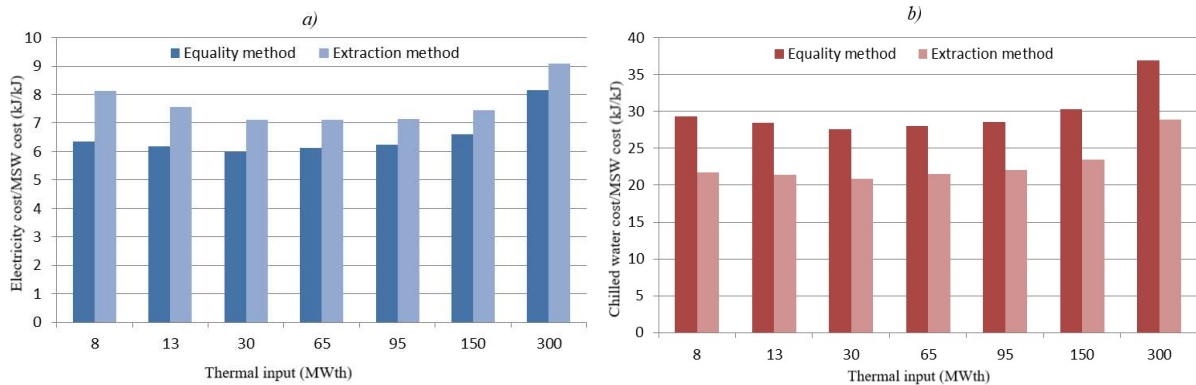

Figure 8 – Ratio between exergy based cost of products (a) electricity, b) chilled water) and MSW

References

- [1] ABRELPE, *Panorama of Solid Waste in Brasil 2014*, available in <http://www.abrelpe.org.br/> [in portuguese]. 2014: Sao Paulo.
- [2] Brazilian Institute of Geography and Statistics, IBGE. Available at <http://www.ibge.gov.br/> [accessed 15.03.2016]
- [3] MMA, *National Plan of Solid Waste [in portuguese]* 2012, Ministry of Environment: Brasilia.
- [4] JÚCA, J.F., *Final Destination of Solid Waste in Brazil [in portuguese]*, in 5° *Brazilia Environmental Geotechnics Congress*. May 2003: Porto Alegre, RS. p. 32.
- [5] Luz, F.C., et al., *Techno-economic analysis of municipal solid waste gasification for electricity generation in Brazil*. *Energy Conversion and Management*, 2015. **103**: p. 321-337.
- [6] GONÇALVES MIRANDA, T.L.H., *Energy recovery from urban solid waste: a case study in Ithané-SP municipality [in portuguese]* in *PECE*. 2014, Polytechnic School of University of Sao Paulo: SAO PAULO. p. 121.
- [7] OLIVEIRA PAVAN, D.C.M., *Energy recovery from Urban Solid Waste: evaluation and guidelines for potentially applicable technologies in Brazil [in portuguese]*, in *Post graduation program in Energy 2010*, University of Sao Paulo: Sao Paulo. p. 186.
- [8] Gonçalves., et al., *FINAL DISPOSAL OF SOLID URBAN WASTE: ALTERNATIVES FOR THE CITY OF SÃO PAULO BY MEANS OF SUCCESS CASES*. *Future Studies Research Journal*, 2013.
- [9] EPE, *National energy balance 2013 [in portuguese]* available in <https://ben.epe.gov.br/> 2014, Energy research company: Rio de Janeiro.
- [10] GNESD, *Biomass Residues as Energy Source to Improve Energy Access and Local Economic Activity in Low HDI Regions of Brazil and Colombia (BREA)*. 2015, Global network on energy for Sustainable development p. 280.
- [11] Higman, C., van der Burgt, M., *Gasification*. 2nd ed. 2008: Gulf Professional Publishing. 456p.
- [12] Arena, U., *Process and technological aspects of municipal solid waste gasification. A review*. *Waste Management*, 2012. **32**(4): p. 625-639.
- [13] De Souza-Santos, M.L., *Solid Fuels Combustion and Gasification: Modeling, Simulation, and Equipment Operations Second Edition*. 2010: CRC Press
- [14] Di Gregorio, F., *Fuel Gas Technology for Biomass and Waste*, in *Department of Environmental Sciences Second University of Naples*. 2012, University of Naples.
- [15] Consonni, S., M. Giugliano, and M. Grosso, *Alternative strategies for energy recovery from municipal solid waste: Part B: Emission and cost estimates*. *Waste Management*, 2005. **25**(2): p. 137-148.
- [16] Psomopoulos, C.S., A. Bourka, and N.J. Themelis, *Waste-to-energy: A review of the status and benefits in USA*. *Waste Management*, 2009. **29**(5): p. 1718-1724.
- [17] McKay, G., *Dioxin characterization, formation and minimization during municipal solid waste (MSW) incineration: review*. *Chemical Engineering Journal*, 2002. **86**(3): p. 343-368.
- [18] Arena, U., Di Gregorio, F., Amorese, C., Mastellone, M.L., *A techno-economic comparison of fluidized bed gasification of two mixed plastic wastes*. *Waste Management*, 2011. **31**: p. 1494-1504.
- [19] *Technology Characterization: Steam Turbines*. 2002, Energy Nexus Group: Arlington, Virginia. p. 20.
- [20] Moran, M.J., Shapiro, H.N., *Fundamentals of Engineering Thermodynamics, 5th edition* 2006.
- [21] Herold., K., *Absorption chillers and heat pumps*. 1996: CRC Press.
- [22] ASHRAE, *District cooling guide*. 2013.

- [23] Puig-Arnavat, M., J.C. Bruno, and A. Coronas, *Review and analysis of biomass gasification models*. Renewable and Sustainable Energy Reviews, 2010. **14**(9): p. 2841-2851
- [24] *Aspen Plus, Aspen Technology*. 2006: Cambridge, MA, USA.
- [25] Eikeland, M.S., Thapa, R. K., Halvorsen, B. M., *Aspen Plus Simulation of Biomass Gasification with known Reaction Kinetic in 56th Conference on Simulation and Modelling (SIMS 56)*. 2015: Linköping University, Sweden.
- [26] VALDÉS RENTERIA, C.F., *SENSITIVITY MODEL FOR EXERGOECONOMIC OPTIMIZATION OF INTEGRATED GASIFICATION COMBINED CYCLE (IGCC)*, in *School of process and energy*. 2009, National University of Colombia: Medellin.
- [27] Niu, M., et al., *Simulation of Syngas Production from Municipal Solid Waste Gasification in a Bubbling Fluidized Bed Using Aspen Plus*. Industrial & Engineering Chemistry Research, 2013. **52**(42): p. 14768-14775.
- [28] Doherty, W., Reynolds, A., Kennedy, D., *Aspen Plus Simulation of Biomass Gasification in a Steam Blown Dual Fluidized Bed*, in *Book Chapter: Materials and processes for energy: communicating current research and technological developments, A. Méndez-Vilas 2013*, Formatex Research Centre: Dublin.
- [29] Gumz, W., *Gas producers and blast furnaces; theory and methods of calculation*. 1950: New York, Wiley
- [30] Kersten, S.R.A., van der Drift, A., Prins, W., van Swaaij, W. P. M., *Interpretation of Biomass Gasification by "Quasi"-Equilibrium Models*, in *12th, European biomass conference; biomass for energy, industry and climate protection*. 2002: Amsterdam, The Netherlands.
- [31] Radmanesh, R., J. Chaouki, and C. Guy, *Biomass gasification in a bubbling fluidized bed reactor: Experiments and modeling*. AIChE Journal, 2006. **52**(12): p. 4258-4272.
- [32] CETESB, *Panorama of Solid waste of the Sao Paulo State [in portuguese]*. 2014. p. 209.
- [33] Perry, R.H., Green, D. V., *Perry's Chemical Engineers' Handbook, Eighth Edition*. 2008: McGraw-Hill.
- [34] Magrinho, A. and V. Semiao, *Estimation of residual MSW heating value as a function of waste component recycling*. Waste Management, 2008. **28**(12): p. 2675-2683.
- [35] Pellegrini, L.F. and S. de Oliveira Jr, *Exergy analysis of sugarcane bagasse gasification*. Energy, 2007. **32**(4): p. 314-327.
- [36] Szargut, J., David, R.M, Steward, F., *Exergy Analysis Of Thermal, Chemical, and Metallurgical Processes*. 1988, New York: Hemisphere publishing
- [37] IBGE. *Brazilian Institute of Geography and Statistics*, <http://www.ibge.gov.br/>. [accessed on March 2016]
- [38] De Oliveira Junior, S., *Exergy - Production, Cost and Renewability*. 2013: Springer-Verlag London.
- [39] Martorano, L., Antonelli, M., *Fluid machines project [in Italian]*. 2011: ETS
- [40] Kakaç, S., *Boilers, Evaporators and Condensers*. 1991: John Wiley & Sons. Inc.
- [41] Lieuwen, T., Yang, V., Yetter, R., *Synthesis gas combustion : fundamentals and applications*. 2010: CRC Press Taylor & Francis Group.
- [42] Siemens, *Industrial Steam Turbines* <http://siemens.com/energy/steamturbines>, S.A.E. Sector, Editor. 2013.
- [43] Consonni, S. and F. Viganò, *Waste gasification vs. conventional Waste-To-Energy: A comparative evaluation of two commercial technologies*. Waste Management, 2012. **32**(4): p. 653-666.
- [44] Burbano., J.C., *Exergonomic optimization of tetracombined trigeneration systems*. 2011, Polytechnic School of University of Sao Paulo.

- [45] Boehm., R., *Design analysis of thermal system*. Wiley, New York, 1987.
- [46] Ciferno, J., Marano, J., *Benchmarking Biomass Gasification Technologies for Fuels, Chemicals and Hydrogen Production*, in *U.S. Department of Energy National Energy Technology Laboratory*. 2012.
- [47] IFC, *Solid waste management in Curitiba [in portuguese]*. International Finance Corporation, 2015.