

Learning about makers in China

*Original*

Learning about makers in China / Bloch, Anaïs; Bolli, Monique; Protti, Emanuele; Renaud, Clément - In: Realtime : Making Digital China / Renaud C., Bideau F. B., Laperrouza M.. - STAMPA. - Lausanne : PURR, 2020. - ISBN 2889153452. - pp. 135-161

*Availability:*

This version is available at: 11583/2813012 since: 2020-04-20T12:43:54Z

*Publisher:*

PURR

*Published*

DOI:

*Terms of use:*

This article is made available under terms and conditions as specified in the corresponding bibliographic description in the repository

*Publisher copyright*

(Article begins on next page)

REALTIME:  
MAKING DIGITAL  
CHINA

实时







# REALTIME: MAKING DIGITAL CHINA



EPFL PRESS

# COPYRIGHT

---

Cover illustration, graphic design and layout: Maria Roszkowska, DISNOVATION.ORG

---

## EPFL PRESS

---

is an imprint owned by the Presses polytechniques et universitaires romandes, a Swiss academic publishing company whose main purpose is to publish the teaching and research works of the Ecole polytechnique fédérale de Lausanne (EPFL).

Presses polytechniques et universitaires romandes  
EPFL - Rolex Learning Center  
Post office box 119  
CH-1015 Lausanne, Switzerland  
E-mail: [ppur@epfl.ch](mailto:ppur@epfl.ch)

[www.epflpress.org](http://www.epflpress.org)

First edition  
© EPFL Press, 2020  
ISBN 978-2-88915-345-9

All rights reserved, including those of translation into other languages.  
No part of this book may be reproduced in any form - by photoprint, microfilm, or any other means - nor transmitted or translated into a machine language without written permission from the publisher.

Printed in Italy

---



C O N T

---

INTRODUCTION (RENAUD, GRAEZER BIDEAU &

---

01 THE ASCENT OF DIGITAL TECHNOLOGY IN

---

02 PLANNING: FROM MODEL TO MODULES

---

03 PRODUCING STANDARDIZATION: CHINESE

---

04 AN ARCHEOLOGY OF SHANZHAI PHONES

---

05 THE GHOSTS OF SHENZHEN

---

06 LEARNING ABOUT MAKERS IN CHINA

---

07 CHINA.AI

---

08 THE ARMATURES OF A NEW AUTONOMOUS

---

09 SPEED POLITICS OF DANMU

---

10 FUTURE RECIPES

---

CONCLUSION (RENAUD, GRAEZER BIDEAU &

---

---

**E****N****T****S**

---

**LAPERROUZA)****006**

---

**CHINA (RENAUD)****014**

---

**(GRAEZER BIDEAU)****038**

---

**BLOCKS IN NETWORKS (LAPERROUZA)****060**

---

**(RENAUD & DISNOVATION.ORG)****086**

---

**(DE BEL)****110**

---

**(BOLLI, RENAUD, BLOCH & PROTTI)****126**

---

**(DE SETA)****154**

---

**URBANISM (HILGEFORT & LI)****170**

---

**(GE ZHANG)****182**

---

**(WANG)****200**

---

**LAPERROUZA)****218**

---







# REALTIME: MAKING DIGITAL CHINA

In the digital world, speed is set by a clock. Operations from the circuitry—the processor, memory, buffers, etc., are synchronized by the signal sent by a clock chip at regular frequencies—for instance one million cycles, or vibrations per second (1 MHz). With the clock setting the pace of execution, computer systems are said to be *real time* when the result returned by an instruction are not only logically correct, but arrive within a defined deadline. In other words, the concept of real time for computers does not relate as much to speed as to *predictability*.

## LOST IN TIME SCALES

The construction of highly predictable systems is concomitant with the rise of great uncertainties on a planetary scale. Human societies and natural ecosystems are subject to major transformations of climate, exponential demography, new modes of mass control or robotic presence. While computers have long surpassed a pace we can comprehend,<sup>1</sup> the biggest challenge humanity now seems to face is coping with the velocity of these changes.

In an uncertain world, grand narratives of the future often fall short. Computers are used to formulate and calculate timetables,<sup>2</sup> requiring us to form plans and ways to execute them. The predictable outcome of computer simulations contrasts with the growing uncertainty we observe. We often feel lost in planning and time scales, searching for a set of instructions that could finally provide a predictable outcome.

## CHINA SPEED

Arguably, the country on Earth that has undergone the most drastic transformation over the last half century is China. Its urban population went from slightly over 100 million to more than 600 million people between 1978 and 2018.<sup>3</sup> The manufacturing and export of billions of *Made in China* goods shaped entirely new ways of producing and consuming all across the world. Once a relatively isolated nation, the country now occupies a central role in international affairs.

1 The “flash crash” of May 6, 2010, has become a canonical example of how systems can surpass the understanding of mankind. At 2:32 pm EDT, the most important stock indexes in the United States collapsed for approximately 36 minutes, causing a loss of almost one trillion dollars before rebounding and recovering most of the original amount. To this day, the exact reasons for this remain unknown.

2 The Intergovernmental Panel on Climate Change (IPCC) relies on statistical models and advanced computation to define the timeframe of global warming.

3 Statistics from the World Bank, 2018.

All this happened with incredible speed. Anyone who has witnessed firsthand the development of Chinese cities over the past three decades can attest to its velocity. Nationwide infrastructure projects were developed and deployed in a matter of years, including more than 100,000 km of railway tracks and 4,000 km of subway lines. These developments evolved from intense planning through successive five-year and ten-year plans, but also from a surprising sense of urgency and immediacy that has spread over the country.

All across the nation, thousands of people were arriving each day at train stations, bags in hand, ready to start a new urban life. Planners had to develop entire cities to host these newcomers, who were often present illegally. In many cases, urban plans were used to explain and contain what was already happening. Among the population, the dedication to executing tasks at a faster rate was also palpable. Manufacturers would hear a client request, rush back to the factory and work day and night until a prototype was ready to ship. “*On my way to meet a Korean client, I was blowing on the phone to dry the paint!*” remembers a Shenzhen electronics maker with a large smile.

Beyond the anecdotes, China’s experiments conciliate predictable plans with revolutionary events. In many ways, the Chinese economic reforms directly evolved from the experience of the guerrilla. Yuan Geng (1917–2016), author of the famous slogan “*Time is Money, Efficiency is Life,*” was at the same time a war hero, a policy-maker and a Shenzhen business magnate. For his generation, speed was a necessary means in achieving victory. Today, this legacy, while gradually fading, remains foundational.

#### THE CITY-ON-A-CHIP

Since the 1990s, communication devices and the Internet have played an important role in the transformation of our world. By 2018, half the planet’s population had access to a network of computers.<sup>4</sup> Beyond humanity itself, billions of machines are now exchanging information daily. Direct communications continue to raise new questions about the ways habitants, cities and nations comprehend time and space.

Indeed, why should urban composition be based on the spatial order of places and roads when we can find our own way using a text search? Why should we wait to interact physically when an interface able to react in under a tenth of a second feels instant? One of the most outwardly visible actions of computers is to reorganize space. Cities, like computers, evolved from the same necessity of humans to organize things and thoughts into functions and zones.

In this regard, the technocratic dream that predates the “*smart city*” is a very old one. The city is classically represented as a machine, with vertical dynamics of institutions and horizontal ranges of possibilities. With computers networks

4 55% according to Internet World Stats, 2019.

and robotics, these structures are redefined, with new forms of control shaping existing and potential spaces. Even in the places we inhabit daily, power and dreams are projected through many different channels.

In most Chinese cities, digital technologies are omnipresent. With both the largest urban areas and the largest electronics manufacturing industry in the world, the country has created entirely new models of production, use and regulation of information technology. As with urban development, the emergence of these technologies has followed both chaotic paths and well-thought-out plans. Digital devices have been deeply integrated into urban spaces, from LED screens and phones, to cyber-cafes, surveillance cameras, drones and robots.

#### ABOUT THE BOOK

This book intends to provide an account from the digital and urban worlds of China. For decades, scholars, think tanks and agencies, both local and global, have been observing and predicting the rise of China's technological power. Research about technology in China has mostly attempted to understand and describe its local specificities, often in order to make recommendations and adjust for competitive advantages. This book asks a different question: how can China inform our relationship with technology?

We envisage China as an important proving ground to learn about ourselves as humans. Instead of attempting to formulate a single and structured analysis, our intention is to incite questions by making unfamiliar links and offering a glance at multiple aspects of digital technology in urban China. This book proposes a fragmented vision made of observations, original documents, scientific research, art projects and fictional content. The title REALTIME expresses a common feeling present in these contributions, one that usually occurs when everything around seems very fast, loud and real.

This volume is composed of two sides—graphical on the left, textual on the right—so as to offer the reader an experience that is both analytical and sensory. It contains perspectives from researchers and practitioners across various fields including geography, anthropology, economics, design, architecture and art.

The opening three chapters provide the larger context, with a historical overview of the ascent of digital technologies in China (chap. 1), a spatial perspective on the planning of cities (chap. 2) and a geopolitical look at the evolution of China's role in defining global technological standards (chap. 3). The bulk of the volume is dedicated to observations collected from the field, including a unique collection of *shanzhai* phones (chap. 4) and an exploration of Shenzhen's night markets in search of second-hand electronics (chap. 5). Chapter 6 narrates a methodological experiment for studying makerspaces in China. The following three chapters present accounts of home-grown Internet phenomena, namely the media propaganda surrounding artificial intelligence (chap. 7), the evolution of rural e-commerce villages (chap. 8) and the popular activity of live

commenting directly over online videos (chap. 9). The final chapter is a work of fiction that attempts to articulate a potential future of China's technology through food and recipes (chap. 10).

Together these contributions constitute a small but significant sample from the vast spectrum of technology in China. They remind us that technology, before being from any specific nation, is deeply human.

Clément Renaud

Florence Graezer Bideau

Marc Laperrouza



THE ASCENT OF DIGITAL TECHNOLOGY IN CHINA 数码科技在中国的延伸





# THE ASCENT OF DIGITAL TECHNOLOGY IN CHINA

---

数码科技在中国的延伸 | Clément Renaud

---

Over the last few decades, the harsh international competition between nations for technological domination has shifted towards digital technology. This global rivalry has largely contributed to framing technology in China as a direct continuity of the Chinese state. Discourse around the Internet in China—the so-called “*Chinese Internet*”—has been fueled by techno-nationalisms both in and outside of China, enhancing the need for nation-states to reassert their power in the face of increasingly complex production and communication networks.

Historical references and analogy (such as the Great Wall) have been present since the early days of the Internet in China, and provided a historical anchor for national claims over computer networks. Digital technology has often been renamed after Deng’s socialism epithet, the famous “*with Chinese characteristics*.” This self-reinforcing narrative of digital China’s otherness pleased both the Chinese and non-Chinese sides, as it offered a comfortable frame of reference for national or regional issues.

To consider the world of technology as competing sides fails to address the most important underlying issues and questions we are facing. We need to understand how digital technology operates and contributes to our world’s current changes—both within China and elsewhere. The prevalence of a national frame of reference helps support scientific and business claims but prevents us from exploring more precisely the political and societal negotiations expressed in successive technical decisions that created digital technology in China, and their relevance to our world as a whole.

In this chapter, I will present an overview of some important moments in the history of digital technology in China. The construction of China’s digital edifice has involved a complex set of local, national and international actors, fueled by various ambitions. The present text aims at observing these dynamics and exposing their diversity within and outside of the country.

Oct. 14, 1952

L. YUTANG

2,613,795

CHINESE TYPEWRITER

Filed April 17, 1946

17 Sheets-Sheet 1

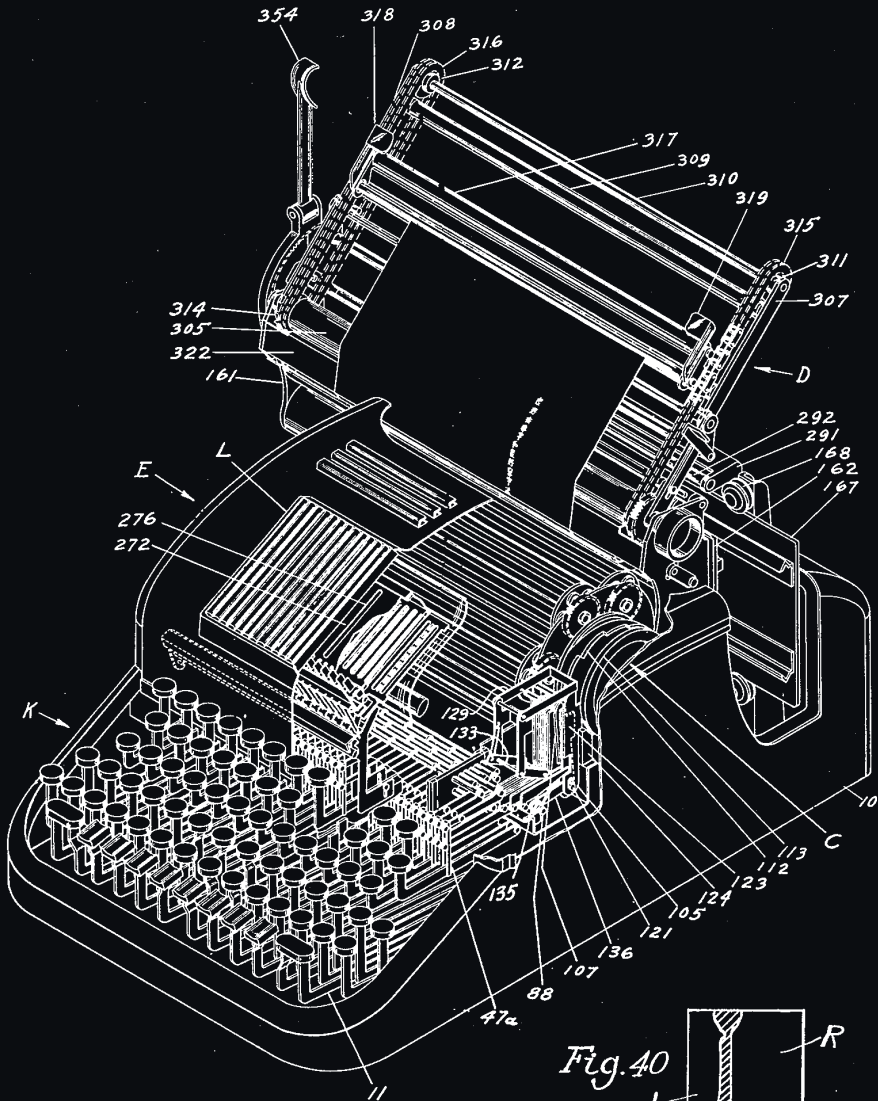

Fig. 1.

Fig. 40



Inventor

LIN YUTANG

MING KWAI CHINESE TYPEWRITER.

Throughout the 19th and 20th centuries, the Chinese language was considered cumbersome and unfit for the expression of modern ideas by many reformers both in China and abroad. The global expansion of the Remington ignited fervent discussion on the necessity to romanize it. Patented in 1952, the Ming Kwai (明快, *mingkuai*, literally "clear and fast") was the first typewriter that allowed the retrieval of 8352 Chinese characters from the input of a compact keyboard (Mullaney 2017).

## THE GLOBAL RACE TOWARDS INNOVATION

In the global technological race, the rush towards “innovation” seems to have replaced the previous quest for “progress”. Today, the concept of innovation acts as a catalyst for the political ambition of outperforming the neighbors.<sup>1</sup> Vast public and private investment programs aim at building organizations to capture markets defined by scientific and business strategies, where newness and invention are pursued as technological achievements, often at the expense of social improvements.

Digital technology, framed as a major engine of innovation, is usually received by two opposing and complementary views: the utopian and the dystopian, claiming either redemption or damnation by means of technology. This tension is omnipresent in most discourse around digital technology in China with the canonical example of *Alipay* being alternatively introduced as a futuristic and desirable mobile payment system or an Orwellian “social credit score” system enabling mass surveillance.

More than debunking one or the other, to consider digital technology in China requires framing it as a part of the country’s experience over the last several decades. The lives of hundreds of millions of people have been radically transformed over this period, partly by massive relocation movements from the countryside to megacities. The incredible diversity of these experiences provides the historical, political and daily context of where digital technology occurs in China, simultaneously locally and with numerous consequences across our planet.

To say it another way, technology exists—in China and elsewhere—not as a standalone set of tools but as an integral part of our daily lives and as a direct product of political and societal settings (Feenberg 1991). The history of technology is not a succession of innovations or inventions, but the long unfolding of evolving uses and solutions that societies create (Edgerton 1999). The inheritance of centuries of practices, technology exists as a complex form of human memory (Leroi-Gourhan 1964) and therefore should be understood outside of any possible national boundaries. More than anything, technology and its artifacts emerged from the entanglements and encounters of existence, a process sometimes described as “*creolisation*” (Nova & Vacheron 2015).

## IS INTERNET IN CHINA REALLY DIFFERENT?

Arguably, the most important learning from China is that digital technology should not simply be considered as a communication tool (the “media”), nor as an infrastructure, but more as a new writing and control capacity. This control capacity exists not as a monolithic, top-down and unified force, but as a negotiation between numerous actors (governmental bodies, investors, private companies, manufacturers, end users, etc.) to distribute and delegate power across a vast network. In other words, writing at scale allows the creation of a

<sup>1</sup> This trend culminates in global rankings such as the Global Innovation Index published by the WIPO and used to evaluate throughputs and outcomes of national policies.



SEAGATE HARD DISK IN WUXI, JIANGSU.  
Workers at Seagate's Wuxi Factory perform final testing and quality assurance on its 2.5-inch notebook drives before sending them off to customers.

deep and previously unknown administrative structure that has the particularity in China of explicitly matching part of the existing political organigram. For instance, the Cyberspace Administration of China—the country’s central Internet regulatory agency—answers directly to the Central Cyberspace Affairs Commission, which is headed by the CCP’s General Secretary and President of China, assisted in this task by his Premier.

Beyond this formal administrative structure, the Internet in China—and elsewhere—evolved from the daily proximity and contradictions between state administrators, companies, technicians, users, etc. Sadly, the lack of a comprehensive approach across disciplines in English-speaking scientific literature (Herold & de Seta 2015) has produced mostly caricatural narratives about the Internet in China, it being a force for either democratization or totalitarian control—as well as a splendid marketing tool.

Debating the Internet in China has long provided a safe framework for critics, scientists and editorialists to demonstrate how the Internet could “go bad,” while preserving enthusiasm about their own technological condition—and their own sales plans. Recently though, the dystopian tone solely used to describe digital technology in China has gained momentum across other areas of discussion, bringing new perspectives on the Chinese example. To make things easier, we could date this shift in perception to June 6, 2013, when Edward Snowden published his revelations on the surveillance practices of several US government offices. Occurring in Hong Kong, the “*Snowden moment*” shed light on unknown administrative mechanisms and structures of digital networks, revealing the extent of control wielded by the US government over them. As a direct consequence, it provided a great opportunity for editorialists in China to reassert their national claims over the Internet.<sup>2</sup>

The governability of digital systems has been a longstanding concern of nation-states, and remains a top priority today—especially in the recent wake of claims around election manipulation. Upon its inception, the Internet was considered a threat to sovereignty as states were unfit to regulate “borderless” networks (Wu 1997). Even its most fervent defenders introduced cyberspace as a “competing sovereign” (Lessig 1998), culminating in the publication of Barlow’s *Declaration of Independence of Cyberspace* in 1996 to counter the US National Telecommunications Act. While regulatory frameworks were gradually becoming clearer, a growing number of figures emerging from the “hacker generation” rose to important political positions, exacerbating the importance for nations and governments to transition into platforms (O’Reilly 2011).

These slowly spreading considerations were accelerated by the “Snowden moment,” leading to a worldwide shift in many governments’ tones. The Wuzhen Declaration and the speech by China’s president Xi Jinping on December 6, 2015,

<sup>2</sup> The *People’s Daily* published on June 23, 2014, an editorial entitled *Cyber Sovereignty, A Question Difficult to Avoid* (网络主权, 一个不容回避的议题)

*Cang-Jie inventeur des caractères chinois*



TOP: Cangjie (Chinese: 倉頡) is a legendary figure in ancient China (c. 2650 BCE), who claimed to be an official historian of the Yellow Emperor and the inventor of Chinese characters. Legend has it he had four eyes, and when he invented the characters the deities and ghosts cried and the sky rained millet.

BOTTOM: The Cangjie Input method was invented in 1976 for inputting Chinese characters on a standard keyboard.

urging countries to reassert their “cyber sovereignty” made a few converts, with this Chinese concept finding its way up to the EU commission.<sup>3</sup> While the existence of pirates as a common enemy was instrumental in the creation of peace in Westphalia,<sup>4</sup> the consolidation of digital technology around national defenses also required the threat of pirates and hackers—such as Snowden. Here, China does not appear as an outlying, insulated player in its country-wide network, but as a seductive model for nation-states feeling threatened.

#### RECONSIDER DIGITAL TECHNOLOGY

Before going any further, we need to address the question of what we mean by *digital technology*. More than just another human tool, we envision digital technology as a direct continuation of the history of writing. Technically, processes such as photolithography on semiconducting materials inherits directly from successive generations of writing machines (lithography, micro-photography and other printing processes). Socially and economically, practices and organizations in human societies have undergone tremendous transformation since the apparition of digital writing, with radical changes in key sectors such as scientific research or accounting. Politically, it appears that many of the power structures observable in the digital world present similarities with past traditions of writing (Guichard 2017).

Writing is more than merely a tool for territorial and resource management. Goody (1977) has shown how alphabetization was a transformative experience of the mind—creating a new framework with which to visually and logically order thoughts. In many regards, new writing technologies transform the way we think—and the way thinking is regulated. During successive Chinese empires, characters, measurement systems, maps and virtually all writing systems were used to standardize practices and unify the Chinese territory. The current official history in the PRC dates the birth of China to the inception of the Yellow Emperor, whose first action after seizing power was to ask a famous scholar to create a new writing system to unify the territory. In the *Analects*, Confucius explains to his disciple that the first thing a new ruler coming into power should do is to “rectify words”.<sup>5</sup>

The early use of the Chinese printing press also greatly facilitated the compilation of studying materials for Imperial examinations. The circulation of these texts was an important political concern, and a stepping stone for the emergence of a gigantic bureaucracy under the rule of the Mandarins. Mao Zedong himself understood this very well, making his *Little Red Book* one of the most circulated books in the world with an estimated billion copies in circulation.

3 See, for instance, the report *Towards a European Digital Sovereignty Policy* published in 2019 by the Section for European and International Affairs (ESEC).

4 For more about pirates as *hostis humani generis*, see the excellent *Mercenaries, Pirates, and Sovereigns: State-Building and Extraterritorial Violence in Early Modern Europe* by Janice E. Thomson (1994)

5 “必也正名乎”——“Tsze-lu said, ‘The ruler of Wei has been waiting for you, in order for you to administer the government. What will you consider the first thing to be done?’—The Master replied, ‘What is necessary is to rectify names.’” in *Confucius Analects*—13.3 (James Legge, trans.)



CONSOLE OF THE 109C AT THE PEKING INSTITUTE OF COMPUTING TECHNOLOGY.  
The Chinese inscription is a quotation from Chairman Mao (Science 1973).

In many regards, digital technology in contemporary China emerged from the need to rebuild a new form of bureaucracy. Like in Imperial times, the digital writing system regulates different spheres of public and private life by providing an infrastructure for territorial administration.

For the Chinese Communist Party (CCP) who seized power after the Second World War, rebuilding the country was not only an economic endeavor but also a grandstanding mission to reinvent China. Therefore, a new set of writing tools were needed. The Chinese language was reformed and simplified, with vast literacy campaigns conducted across the population. The goal was not only to teach the people to read but also to increase the political outreach of official statements, which gradually evolved to claim a continuation of the ancient Chinese civilization (*wenming*).<sup>6</sup> It was no surprise then, that the formidable writing capacity unleashed by digital technology was to become a major vector of the country's political and societal transformations—as well as partially reproducing Imperial power and knowledge structures.

#### THE NEW *LITERATI*: THE DREAM OF THE RED ENGINEERS

At the end of the 1970s, the Cultural Revolution had left the country benighted. Research centers and universities had been closed for a decade, and the Chinese Academy of Sciences (CAS), the heritage of the Soviet Academy of Sciences, was a small and powerless institution. On March 18, 1978, Deng Xiaoping, leading the vast Reform & Opening plan, announced in front of more than 6,000 scientists freshly returned from the countryside, that science and technology were now considered at the forefront of China's reconstruction. Deng's new doctrine of "*socialism with Chinese characteristics*" was based on an interpretation of Proudhon's "*scientific socialism*." Therefore, Chinese governance should rely on comprehensive scientific—instead of ideological—reasoning.

While Mao or Deng's experience was mostly with the military in the People's Liberation Army, rebuilding the country required different skills. Hundreds of thousands of engineers would have to build roads, bridges, ports and cities for the whole country over the following decades. Called the "Red Engineers" (Andreas 2009)—in contrast to the experts and political agitators of the Cultural Revolution—this new generation pursued higher education in science and technology.

Chinese engineers rapidly grasped the importance of computers. From the new possibilities of information storage and computation to nationwide distribution networks, the potential of the computer was virtually unlimited. In 1989, Jiang Zemin was named General Secretary of the CCP and would soon become China's president, and the first engineer to ever hold this position. Having studied electrical engineering during the Japanese occupation, he understood the

<sup>6</sup> In Chinese, *wen* (文) means writings and literacy. Civilization is often translated as *wenming* (文明), a word that can be understood as *light of writings* or *to be enlightened by literacy*.



**INFORMATION HIGHWAYS AND GOLDEN PROJECTS.**

In parallel to the US, another main communication megastructure was developing – in China.

importance of telecommunication networks for the country.<sup>7</sup> Early on, he visited US facilities in Silicon Valley and decided to send his own son Jiang Mianheng, who would become one of the leading figures of the early Internet in China, to the mythical Xerox PARC.

#### THE FARMER AND THE ENGINEER: TO BUILD AND CONNECT A CHINESE COMPUTER

Even during the Cultural Revolution, computers were already part of the country's development effort. A group of American computer scientists visiting China in the 70s were surprised to find a production chain of computers:

“The factory that previously produced handles for doors and windows, with housewives as workers, was reorganized in cooperation with the Shanghai Computing Research Institute in order to produce an integrated circuit digital computer. In all of our discussions, the Chinese referred to the factory as “the window handle factory”, and it was pointed out that most of the 90 employees in its electronic workshops were the same housewives who had been there during the handle days.” (Cheatham et al. 1973)

On September 20, 1987, Chinese and German teams managed to establish an X.25 connection in order to send the first email from China. The message was entitled “*First Electronic Mail from China to Germany*” and had for content “*Across the Great Wall we can reach every corner in the world.*” A few months later, the Taiwanese contract manufacturer Hon Hai Precision Industry Company Ltd opened its first plant in the Shenzhen Special Economic Zone to produce joysticks for Atari video game consoles. The company (later known as Foxconn Electronics) would become one of the largest employers in the world—employing one million workers in 2015—and the plant one of the largest as well—housing more than 200,000 workers. Meanwhile the city of Shenzhen, first designed as a pilot for China's early experiments with capitalism, would transform from a small border town into a global technological center.

In 1991, just a few years after that first email, the Clinton administration launched its *Information Highways* program. The Chinese administration quickly followed in 1992, with the launch of a dozen major initiatives known as *Golden Projects* to build communication infrastructures across the country (Lovelock et al. 1996). While the most famous is the Golden Shield—nicknamed the *Great Firewall of China* by Californian editorialists (Ye & Sang 1997), the Golden Projects covered multiple aspects of the country's administration: customs, banking, taxes, reporting of public spending, etc. Like the *Information Highways* for the US, this comprehensive investment plan laid out the blueprints for China's digital world as we now know it.

<sup>7</sup> “The electronics industry plays an extremely significant role in modernization, and we should place great emphasis on its development and progressively use electronic technology in all sectors of the national economy.” (September 11, 1983; p. 73)—in Zemin, Jiang. 2010. *On the Development of China's Information Technology Industry*. Singapore: Academic Press.



TENCENT QQ.

In 2014, *Tencent QQ* had more than 800 million active accounts. More than just a messaging tool, the application includes games, blogs, online avatars and many services that became a central part of daily life on the Internet in China.

## A PUBLIC INFRASTRUCTURE OF WRITING

As shown by Ang (2018), local bureaucracy in China has developed as an adaptive system, where large master plans encounter unplanned events, and tactics inherited from the revolution were used to attract foreign investments, reform lands, etc. The Special Economic Zone of Shenzhen is a prime example of this dynamic. Originally designed as a model city and a zone for experiments, it quickly became an Eldorado for those willing to reap the benefits of China's recent opening. Millions of Chinese workers relocated to the SEZ, where a new *dagong* lifestyle emerged around factories and spread across China (Florence 2017). This lifestyle was associated with the hi-tech image of the electronics the city produced. A prototype of a larger societal and economic project, Shenzhen was hi-tech since its inception and would continue to stand at the crossroads of the country's urban and digital transformation.

China's urban population has gone from slightly over 100 million to more than 800 million people<sup>8</sup> at the time of writing. Looking at these incredible numbers, it can be argued that one of the major factors of Internet adoption in China was the need for people arriving in new cities to stay in touch with their families and friends at home. Until recently, the mobile phone was known as the "first urban purchase" for rural migrants arriving in a Chinese city (Wallis 2013). What better opportunity for Internet companies than hundreds of millions of people on the move who need to communicate? From apps to cable laying, many of the companies that emerged around the Internet in China have relied on tasks usually associated with infrastructure building (Plantin & De Seta 2019).

Tencent offers an interesting case of the interrelation between urban and digital development in China. At a time where intercity phone calls were still relatively expensive on the mainland, the company began providing a messaging service called QQ that allowed for text and call chat online. Based in Shenzhen, it quickly grew to reach hundreds of millions of users, expanding to include a blogging platform, online avatars, and even a digital currency in 2005—the year Facebook officially launched. With the arrival of mobile technologies, a new application called *WeChat* was created as a side project that eventually became a central piece in almost every aspect of digital personal and professional life in China, with chat, apps, payment and booking systems, etc.

Alibaba, another famous company, has taken up the task of facilitating commerce across China with digital technology. Originally known as the first digital company in China to attract substantial foreign investment, it arrived at a time when it was still difficult to source, buy and sell products outside of a few major cities in China. Alibaba took up the role of intermediary between factories, resellers and consumers, building the spine of China's logistics and distribution network. Moreover, the Chinese population was discovering consumption after years without private property. Online marketing and

8 Estimation by the World Bank, 2018.



**CYBER CAFES, CHINA.**

Before mobile connectivity, cyber cafes (*wangba*, 网吧) were the most important venue for Internet access in China's urban and rural communities. Reports from the China Internet Network Information Center estimate more than 400 million people accessed the Internet from cyber-cafes between 2006 and 2010.

sales played an important role in training Chinese city newcomers to consume in the urban environment by delivering advertisements and goods closer to them.

Interestingly, both companies evolved to provide digital payment services. In China, the relatively low penetration of credit and debit cards allowed them to address cash management directly with their own Internet-based solutions. More than just profitable “start-ups,” their mission was understood as part of a larger—national—agenda of development: to provide access to banking and cash facilities to the majority of the population. China’s regulators supported these companies with national policies, and in return outsourced tasks such as data collection to their care.<sup>9</sup>

To some extent, these companies can be perceived as public service providers for the country. Compared to Western counterparts that have often focused on middle-class urban users, Chinese big tech companies serve a billion highly diverse people, from farmers in remote mountains to the highest spheres of China’s urban elite.

Supporting versatile life experiences, Chinese Internet companies provide infrastructure, capital and occasionally high-profile role models—like Jack Ma from Alibaba or Pony Ma from Tencent. Their services have become not only a daily habit but an important constituent of social stability. As builders of the key infrastructures of a new Chinese society, they operate not only closer to the government but as an integral part of the country’s administration—even though they may have been privately structured. The exclusion of US Internet players such as Facebook or Google, often presented as censorship or economic protectionism, could also be considered as a way to build and retain a national infrastructure of services.

#### THE ADMINISTRATION OF CONTROL

The integration of these diversified private companies into the core competencies of public institutions somehow contradicts the image of digital technology in China as a centralized government. Companies, as providers of advanced writing and logging systems, have mandates—either solicited or imposed—to perform tasks for public service. For instance, Alibaba now operates online semi-autonomous tribunals to settle the numerous conflicts that arise during payment litigations and fraudulent activities on its own platforms. Case instruction processes are automated, and hearings are handled by sworn judges via remote video calls.

In many regards, the build-up of China’s legal and administrative system is happening in the digital age. Compared to centuries of jurisprudence in the US or Europe, the PRC’s legal system is relatively new, with concepts imported from traditions as different as Germanic-style civil law, socialist law and

<sup>9</sup> For instance, by instituting a mandatory clearance by a state institution. See Wildau, Gabriel. 2017. “China Targets Mobile Payments Oligopoly with Clearing Mandate.” *Financial Times*, August 9, 2017.



BITCOIN MINING FARM PROTOTYPE, BEIJING, CHINA.  
The first "baby mining farm" built in a suitcase of 20 stacked FPGAs in an apartment in Haidian district, Beijing, in 2012.

Chinese Imperial law. To cope with the lack of extended jurisprudence, the administration is relying more and more on the vast amounts of data produced by the population, via tech companies or the administration itself.<sup>10</sup> The integration of data into a national infrastructure allows the Chinese government to create new bureaucratic solutions to regulate its territory—partly realizing Lessig’s claims that *Code is Law*.

An interesting example can be found in banking regulation. Chinese people have traditionally accessed credit through their family and social networks—through *tontines* and shadow banking. Recently, banking and social networks have merged, giving rise to a P2P lending sector where individuals lend money to each other through mobile messaging apps such as Alibaba’s Alipay. To face the fast-growing issues of insolvency and bankruptcy, the government tasked Alibaba to create a score that linked credit history data with user accounts in order to make sure people were solvent and insurable. Inspired by its Anglo-Saxon equivalent, Alibaba’s *Sesame Credit* is meant to recreate a buyer–seller or buyer–lender trust and verification system. It is based not only on credit history, but also on payments, previous litigations and in-app social relationships. Poor rates can lead to being “blacklisted” which can go as far as blocking the user’s access to his bank account, or reporting them to the police in cases of recurrent fraud.

Beyond the quest for efficiency via automation stands the larger project of building a technological system able to transform not only society but each individual. Social apps and websites exist in this process as major instruments to redefine not only practical abilities but also spaces of representations where new possibilities appear. Like the novels of 19th-century Europe, the new digital writing system aims at making humans more prolific and exemplary by spreading moral, behavioral and financial injunctions. While the in-app credit score is a prominent example in China, it echoes the case of millions of drivers, freelancers, shop owners and workers worldwide whose work increasingly depends on social platform rankings.

#### TOWARDS A GLOBAL WRITING SYSTEM

The emergence of a civil society in China has been supported by online discussions and campaigns (Yang 2003), and so did its control and regulation. Not only can regulators now access vast amounts of data for decision purposes, but they can also rely on digital interfaces to enforce these decisions. This integrative writing system offers a new level of control to the administrators. Navigating cities relies extensively on digital apps, from taxis, payments, video surveillance and even facial recognition, providing data to refine and enact new forms of statistics-based policies. Beyond smart city narratives, urban areas also act as a large data field that informs the rest of the country. While very large companies have emerged from China’s first wave of coastal urbanization, the country’s development towards inner and rural countryside is creating new

<sup>10</sup> Several existing and planned applications were presented during the *World Artificial Intelligence Rule of Law Forum* (世界人工智能大会法治论坛) organized by the Shanghai Law Society in September 2019.



CHINESE NEW YEAR'S EVE CHOREOGRAPHY WITH 540 ROBOTS & 29 DRONES.  
The Chinese New Year Gala is broadcast on Chinese TV every year. An integral part of the Chinese Spring festival experience, it is the most watched TV show in the world (eclipsing even the final of the World Cup). In 2016, 540 robots & 29 drones danced to the lyrics of a famous singer.

private operators. Firms like Pinduoduo have focused on third and fourth-tier cities, developing new links between local production and national reseller networks. Alibaba has also reinforced its *Taobao Villages* program to extend existing supply chains to rural areas via direct online sales towards the mainland and abroad. Once again, digital technology is used as a direct vector for the country's economic, industrial and administrative integration.

China's writing infrastructure has expanded far outside the country. The city of Shenzhen stands as the storefront<sup>11</sup> of vast investment programs facing towards the Middle East, Eastern Africa and Europe—such as the Belt and Road Initiative. For policy planners, the Shenzhen SEZ was originally designed as a working prototype of the (post) industrial city. Today, SEZs following this model have opened in different places around Africa and Southeast Asia. The whole Pearl River Delta region is being integrated into a single giant urban hub, bringing together tens of millions of people and the biggest industrial capacity on Earth, with heavy investments in sectors like robotics, genomics and energy. Such gigantic integrative dynamics rely not only on projections in time and space, but also on the extension of digital technologies to administer new domains of activities and life in a world of limited resources.

## CONCLUSION

Technologies developed in China have now become central pieces of our global writing infrastructure. To understand their significance requires stepping back from national contexts and considering them as an expression of a common and planetary historical momentum, where the emergence of a new writing and control capacity coincides with major changes in natural ecosystems. The early framing of the Internet in China as a remote manifestation of technocratic hubris has contributed to recreating the traditional view of China as a self-centered and isolated area of the world. This discourse provided comfortable support for different economic and political interests in China and worldwide but has also prevented us from considering the important entanglements and similarities between writing systems worldwide.

With the dwindling of natural reserves and automation growing worldwide, digital networks are increasingly being used to regulate behaviors. These new written forms are redefining not only borders and boundaries, but generally regulating our relationships with our surroundings and environment. Beyond nation-states, our new conditions of existence require the building of new critical narratives, where the ascent of digital writing stands as a common endeavor.

<sup>11</sup> Shenzhen is home to some of the largest tech companies in China such as Huawei, Tencent, DJI or BGI.

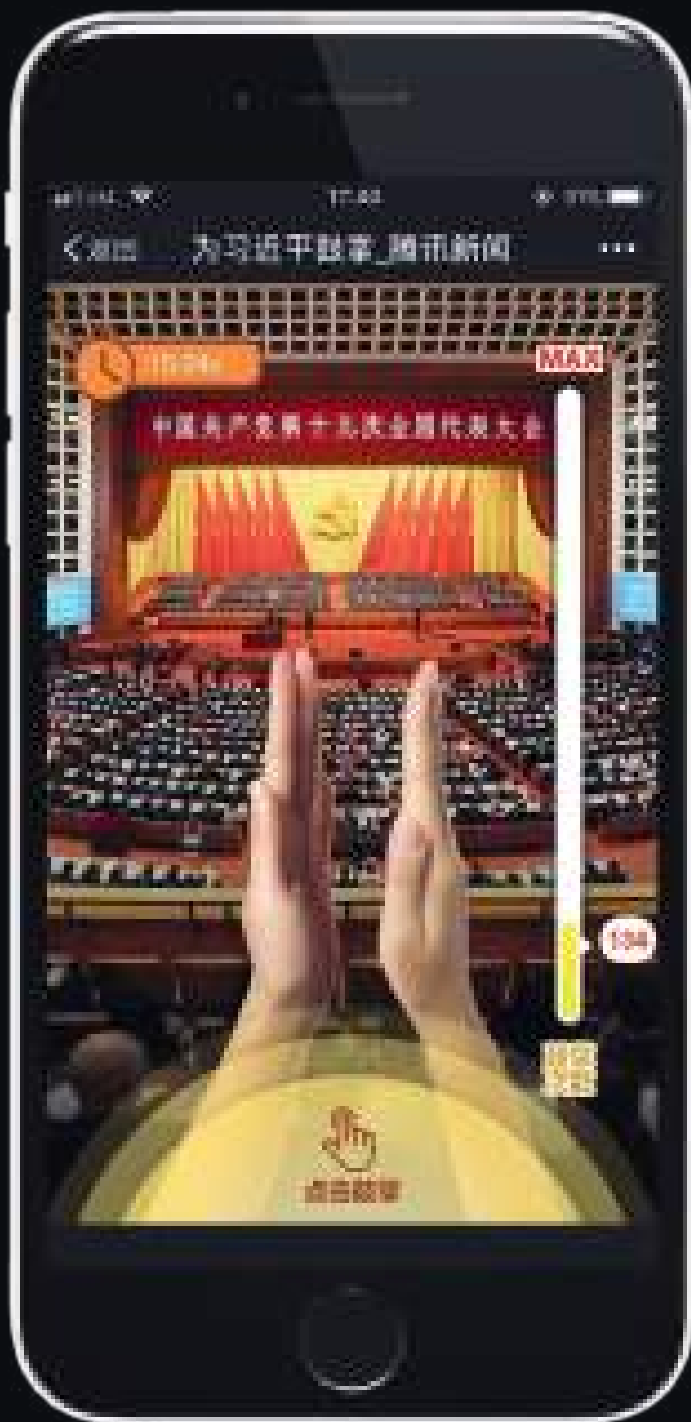

**CLAP FOR XI JINPING.**

The application Clap for Xi Jinping (为习近平鼓掌) was released on October 18, 2017, by Tencent Media for the Chinese Communist Party's 19th National Congress. Users could watch the president's speech and had 19 seconds to tap the bottom of the screen as many times as possible to clap along. The game was played hundreds of millions of times just a few hours after its release.

## REFERENCES

- Andreas, Joel. 2009. *Rise of the Red Engineers: The Cultural Revolution and the Origins of China's New Class*. Stanford: Stanford University Press.
- Ang, Yuen Yuen. 2016. *How China Escaped the Poverty Trap*. Ithaca NY: Cornell University Press.
- Cheatham, Thomas E., Wesley A. Clark, Anatol W. Holt, Severo M. Ornstein, Alan J. Perlis, and Herbert A. Simon. 1973. "Computing in China: A Travel Report." *Science* 182 (4108).
- Edgerton, David. 1999. "From Innovation to Use: Ten Eclectic Theses on the Historiography of Technology." *History and Technology* 16 (2): 111–36.
- Feenberg, Andrew. 1991. *Critical Theory of Technology*. Oxford: Oxford University Press.
- Florence, Eric. 2017. "How to Be a Shenzhener: Representations of Migrant Labor in Shenzhen's Second Decade." In *Learning from Shenzhen: China's Post-Mao Experiment from Special Zone to Model City*, Chicago: Chicago University Press, 86–103.
- Goody, Jack, and John Rankine Goody. 1977. *The Domestication of the Savage Mind*. Cambridge: Cambridge University Press.
- Guichard, Éric, ed. 2017. *Écritures: Sur les traces de Jack Goody*. Papiers. Villeurbanne: Presses de l'Enssib.
- Herold, David Kurt, and Gabriele de Seta. 2015. "Through the Looking Glass: Twenty Years of Chinese Internet Research." *The Information Society* 31 (1): 68–82.
- Leroi-Gourhan, André. 1964. *Le Geste et La Parole*. Paris: Albin Michel.
- Lessig, Lawrence. 1998. "The Laws of Cyberspace." *Readings in Cyberethics* 134: 136.
- Lovelock, Peter, Theodore C. Clark, and Ben A. Petrazzini. 1996. "The 'Golden Projects': China's National Networking Initiative." *Information Infrastructure and Policy* 5 (4): 265–77.
- Mullaney, Thomas S. 2017. *The Chinese Typewriter: A History*. 1st ed. Cambridge MA: MIT Press.
- Nova, Nicolas, and Joël Vacheron. 2015. *Dadabot: An Introduction to Machinic Creolization*. IdPure.
- O'Reilly, Tim. 2011. "Government as a Platform." *Innovations: Technology, Governance, Globalization* 6 (1): 13–40.
- Plantin, Jean-Christophe, and Gabriele de Seta. 2019. "WeChat as Infrastructure: The Techno-Nationalist Shaping of Chinese Digital Platforms." *Chinese Journal of Communication*, February.
- Wallis, Cara. 2013. *Technomobility in China: Young Migrant Women and Mobile Phones (Critical Cultural Communication)*. New York: NYU Press.
- Wu, Timothy S. 1997. "Cyberspace Sovereignty—The Internet and the International System." *Harvard Journal of Law & Technology* 10 (3).
- Yang, Guobin. 2003. "The Co-Evolution of the Internet and Civil Society in China." *Asian Survey* 43 (3): 405–22.

PLANNING: FROM MODEL TO MODULES  
FROM MODEL TO MODULES  
MODULES 城市规划: 从模式到模块 [02]  
PLANNING: FROM MODEL TO MODULES  
MODULES 城市规划: 从模式到模块 [02]  
PLANNING: FROM MODEL TO MODULES  
MODULES 城市规划: 从模式到模块 [02]  
PLANNING: FROM MODEL TO MODULES  
MODULES 城市规划: 从模式到模块 [02]  
PLANNING: FROM MODEL TO MODULES  
MODULES 城市规划: 从模式到模块 [02]





PLAN OF BEIJING FROM THE 17TH THROUGH TO THE 19TH CENTURY, SHOWING IMPERIAL AND ADMINISTRATIVE BUILDINGS.

- 01. Forbidden City
- 02. Ancestral Temple
- 03. Altars of Soil and Grain
- 04. Altar of Heaven
- 05. Altar of Earth
- 06. Altar of the Sun
- 07. Altar of the Moon
- 08. Altar of Agriculture (First Crops)
- 09. North, Middle, and South Lakes
- 10. Jing Shan (Coal Hill)
- 11. Confucian Temple
- 12. National Academy
- 13. Prefectural Administrative Offices
- 14. Yamen (county official residences and courts)
- 15. Granaries
- 16. Buddhist Monasteries
- 17. Daoist Monasteries
- 18. Mosque
- 19. Provincial Examination Hall
- 20. Bell and Drum Towers

# PLANNING: FROM MODEL TO MODULES

---

城市规划：从模式到模块 | Florence Graezer Bideau

---

China has a long tradition of urban planning evident throughout its 3,500-year history (Shatzman Steinhardt 1990). Chinese Imperial city planning has evolved over time in form but their visual characteristics are still related to the ways in which Chinese rulers govern their territory and its population. The Forbidden City is considered by many as a symbol of China. As the capital of five dynasties, it represents the importance of the past in serving the present in the designing of cities. Built in the 13th century, this Imperial monument still serves as a model of urban planning, even after the foundation of the People's Republic of China. It is comprised of palaces, royal monasteries, mausoleums, shrines, altars, parks, government offices, granaries, workshops, treasuries and libraries, all of which were located according to pre-established multisecular traditions. The capital city's form and architecture are symbols of the Chinese ruler, who is also the guardian of such traditions. Considered as an institution, the Forbidden City's concept and design need to be transmitted to future generations alongside its ideology.

This chapter aims to demonstrate to what extent the acceleration of urban development in China is based on the evolution of urban forms. It will describe a process that continues across time and space, that of the fundamental role of urban planning. It will discuss the deployment of the strategy throughout Chinese territory, and the gradual experimentation of urban planners in adapting to new settings, as well as social, political and economic changes. The long-term urban planning of Imperial China with its relatively slow change left room for disruptive and revolutionary experimentations in planning that would eventually adapt to the societal transformation of the urban fabric. Economic reforms launched at the end of the 1990s generated a rapid acceleration on all levels across China — from lifestyle to political systems, especially in the design and management of rapid urban development that challenged modes of production, the politics of land and property, the construction of new towns, urban and rural divides and density populations. Taking the example of Shenzhen, this paper will finally raise the question of whether this city has become a new model for China's urban change.

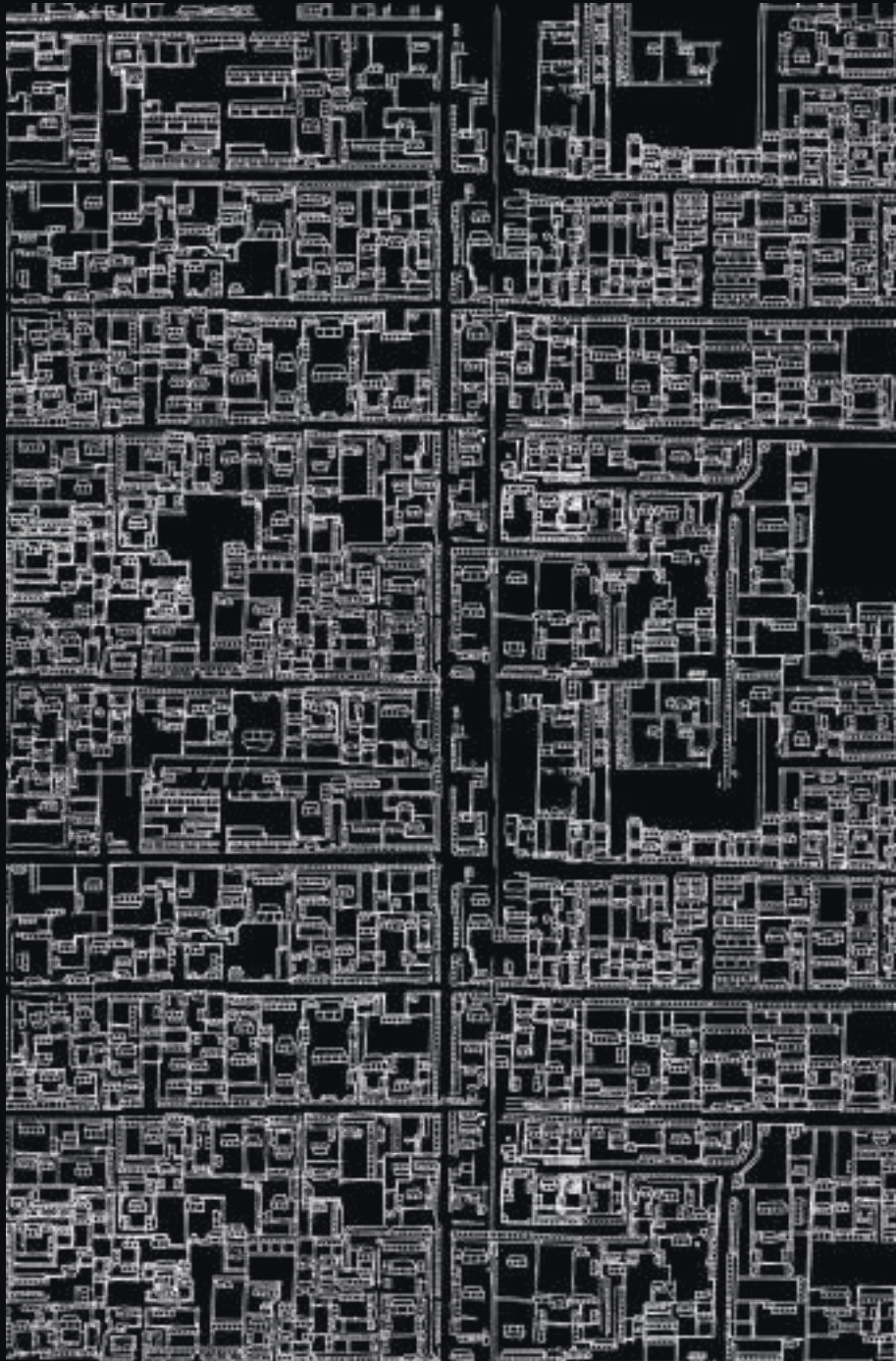

PLAN OF BEIJING IN THE 18TH CENTURY SHOWING THE ORIENTATION OF STREETS, LANES AND ALLEYS TOWARD THE CARDINAL DIRECTIONS.

## IMPERIAL CITY AND THE WALLED CITY

Spatial arrangements of the capital city as a model are fully expressed by the plan of Beijing from the 17th to 19th centuries which shows Imperial and administrative buildings (中国建筑简史 *zhongguo jianzhu jianshi*, fig. 6–12, quoted by Shatzman Steinhardt 1990, 3). Such Imperial plans became uniform and represented the fundamental planning principles to be replicated across the Chinese territories. Principal features included four-sided walled enclosures forming a rectangle—the walled city (*cheng*). Inside, two or more thinner walls composed smaller rectangles in an embedding principle. Equidistant gates pierced the outer (外城 *waicheng*) and inner (内城 *neicheng*) walls usually connected by roads that crossed these rectangles. A major gate was generally built on the southern wall of the city. On the outer walls, defensive positions in the form of large towers or protective battlements housed military troops. Streets were capped by gates. Roads and avenues were designed from north to south and from east to west. This perpendicular grid was then articulated by lanes and alleys (巷 *xiang*), also called hutong in Beijing, which resulted in a checkerboard design.

The four cardinal directions embodied by the north–south and east–west axes were the main benchmarks for navigation. They also symbolically reflected the boundaries of the Chinese Empire. Indeed, according to the traditional belief of the five elements (五行 *wuxing*) associated with the five cardinal points (four geographical directions and the center), the universe was square-shaped and the son of Heaven, i.e., the Emperor who received from Heaven the mission of governing the Earth, was located in its center, i.e., the Forbidden City. Cosmological alignment was crucial to the location of specific buildings. The south was associated with the summer, fire, the phoenix and vermilion. The Emperor’s seat in the Hall of Audiences was oriented south, and every building of the Imperial city had southern exposure. Even today, the north–south axis remains a fundamental feature of Chinese urban planning since it is reminiscent of the Imperial central axis that informed the design of Chinese cities in general.

Starting from the centre of the Imperial city, the vast checkerboard extended over the entire territory of the capital. The microscale structure was applied to the macroscale also, reproducing a system of dividing spaces according to a consistent principal. This dividing of space within the city made population control far easier. Governing the masses was crucial for Chinese rulers due to the relocation of thousands of residents upon the conquering of new territory, and the changing location of the Imperial capital. These controlled areas were inhabited mostly by groups identified by their occupation, religion and ethnic origin. In Beijing this governmentally mandated residential localization persisted until the 20th century.



LOCATIONS OF THE TEN GREAT BUILDINGS AND OTHER MONUMENTS IN BEIJING.  
 01. Tian Anmen 02. Museum of Chinese History 03. Great Hall of the People  
 04. Cultural Palace of Nationalities 05. Hotel of Nationalities 06. Military  
 Museum 07. State Guest House 08. Beijing Train Station 09. Palace Museum  
 10. Beihai Park 11. Coal Hill 12. Beijing Library 13. National Art Gallery  
 14. Hotel of Overseas Chinese 15. Workers' Stadium 16. Museum of Agriculture  
 17. Capital Exhibition Hall (former Soviet Union Exhibition Hall) 18. Beijing  
 Olympic Park

## MAO PLANNING REVOLUTION: TO MODERNIZE AND URBANIZE THE COUNTRY

In the early 1950s, Mao Zedong launched a modernization project for cities.<sup>1</sup> The Chinese capital, Beijing, was at the forefront of such initiatives, including the drawing of maps, the inventory of historical monuments and the building of new national symbols. After much hesitation, he finally decided to keep the Forbidden City as a symbol of China's imperial past, but left a revolutionary mark by enlarging the horizontal axis from east to west between the Imperial buildings and the Qianmen Gate. Chang'an Avenue became the new central axis that provocatively transformed the traditional design of the capital city by adding a horizontal axis that crossed the Imperial north-south axis in the very center of Beijing. This break in urban planning was reinforced with the building of the Tian Anmen square alongside ten buildings erected for the ten years of the People's Republic of China (Wu 2005).

To modernize China meant transforming cities by implementing industries within urban neighborhoods and building new housing facilities for workers and their families, alongside the promotion of a new lifestyle among citizens. To this end, engineers with a technical and architectural education were trained in prestigious universities such as Tsinghua University in Beijing. Students were educated for the purpose of implementing the industrialization process, alongside transport and energy infrastructures and domestic manufacturing facilities, to accelerate the transformation of China. Called the Red Engineers, they were to become a new social class singled out by their technological and ideological expertise (Andreas 2009), who would help China close the development gap in agriculture, mobility, industrial production, science and technology, building, public health, etc.<sup>2</sup> During the next few decades, political campaigns were launched to speed up the process of improving civil infrastructure and public facilities, including sanitation. These campaigns also sought to purify the CCP of so-called bad elements, who were critical or resistant to Mao's effective implementations.

## SCIENTIFIC SOCIALISM IN ARCHITECTURE AND URBAN PLANNING: DESIGNING, EXPERIMENTING, EVALUATING AND REPLICATING

Central to this modernization process were architects and urban planners who followed the Marxist path of scientific socialism—historic forces, mainly economic determinism and class struggles, would help to achieve ideological goals—to perform what was expected of them, i.e., adopting a proletarian worldview and conceiving a design approach suitable for socialist China (Zhu 2009). Educational, productive and professional institutions relating to architecture were restructured, and major institutes of construction, design and planning were established. Influenced by the presence of Soviet experts during the 50s, these professionals were integrated into work-units (单位 *danwei*)

1 The architect Leon Hoa describes this project in detail in his book *Reconstruire la Chine: 30 ans d'urbanisme 1949-1979* published in Paris in 1980 (Éditions du "Moniteur").

2 *How China Escaped the Poverty Trap* (Ithaca, Cornell University, 2016) from political scientist Yuan Yuan Ang is very enlightening to this perspective.



CAOYANG NEW VILLAGE, THE FIRST WORKERS' NEW VILLAGE IN NEW CHINA.

which favored a uniformed practice characterized by a collectivization process involving teams of architects, designers, engineers and other specialists. In order to reach the productivity and economic efficiency required in this period of massive construction, the building industry was nationalized and integrated in five–years plans. This system transformed the practice of architecture: artistic creation was eliminated and replaced by a generic form of basic construction; the signature of a project was anonymized; overall control of a project was impossible due to the progressive division of tasks, and equal pay was applied.

Large teams of about 50–60 people designed new areas within the city in order to implement the concept of neighborhood units, including industry and manufacturing alongside social housing and public facilities (health, education, groceries, administration, services). The goal was to adopt the model of the work–unit to a larger scale within urban redevelopment projects. Relevant experience enhanced early Chinese socialist planning: for example the *Caoyang New Village* built in Shanghai between 1951 and 1953. Designed as a large village with community facilities within walking distance, the first workers’ housing project of Caoyang was intended to host 1,000 households of model workers. Considered an urban pilot for implementing a new village—or in reality regrouping several villages into a single whole—the Caoyang model was designed and expanded throughout major cities where large factories and industries were developed for modernizing China. As a flagship for the CCP, it showcased the new socialist lifestyle and impacted the Chinese urban imaginaries since it reflected Mao’s view of transforming consumerist cities into productive cities.

A few years later, under the expertise of Soviet advisors, Chinese work–units took the form of superblocks (大街方 *dajiefang*) composed of four to six apartment blocks organized around public facilities on symmetrical axes with a certain formalism. Typical of such structures is the *Baiwanzhuang* (百万庄) Residential District in Beijing which serves as residence for government officers and a dormitory for the national textile factory. Designed as an “organic component” within the city, these superblocks were also less expensive to build since they were integrated into redevelopment areas and thus benefited from existing infrastructures instead of new development areas in the suburbs.

#### THE MODEL UNIT OF THE *DANWEI* AS MICRODISTRICT

After the break in diplomatic relations with the Soviet Union, Chinese architects and designers evaluated their previous experiences. They abandoned the superblock form and introduced more flexibility in their planning approach according to economic and topographic issues. The neighborhood unit was transformed in the mid–1950s into the microdistrict, which did not require major changes in the conception of residential planning except for population density and size since the needs of the communities did not evolve much during this period. This basic unit involved a combination of economic activities, civic administration and residences (Lu 2006) and was eventually integrated as a planning norm. This *danwei* (单位) urban model was then replicated and deployed at a larger scale in governmental development projects.



CAOYANG NEW VILLAGE, THE FIRST WORKERS' NEW VILLAGE IN NEW CHINA.

Its implementation was nonetheless challenged by individual work–units that developed their social housing and facilities according to their own wealth and maturation. This urban institution usually started with basic living standards for single workers (dormitories and production structures) surrounded by walls and gates. To meet the needs of its employees, *danwei* evolved to welcome families (apartments, canteens, public baths, groceries and nurseries), educate children (primary schools) and host visitors (guesthouses, restaurants). As the *danwei* gradually developed, it became a semi–autonomous entity that brought work, housing and services into proximity. In the early stages of the market economy, only 10% of urban social housing were municipal government–owned; the majority were owned by work–units. The economic reforms affected the fabric of urban planning and a series of tasks were transferred from governmental institutions to private developers while an array of codes was created to regulate construction of microdistrict models alongside facilities to meet the new lifestyle of Chinese urban citizens (commercial, recreational, dining, administrative, security system, etc).

#### FROM DANWEI TO XIAOQU:

##### AN INCREMENTAL MODULE FOR ADAPTING TO SOCIETAL CHANGE?

In the 1990s and 2000s, the liberal approach to the economy promoted “socialism with Chinese characteristics,” allowing the establishment of the land–lease market, which fostered a rapid urbanization process. Low–acquisition rural lands were gradually transformed into urban areas on a massive scale. Infrastructures and utilities were needed to promote the leases for commercial developers (Hsing 2010). The creation of housing markets produced rapid urbanization and downtown redevelopment. *Danwei* were renovated and sold, possibly to former *danwei* workers, at good prices. Others were gathered and converted into new residential communities (小区 *xiaoqu*) planned and built in accordance with the city’s planning and design principles. Tested during the late 1980s, these housing estates constituted a basic structural unit of urban residential district planning, with clear boundaries, medium size, daily facilities and services, inner circulation systems and green spaces. The form and type of these units varied greatly from city to city. This “commodity market” (Liang 2014) transformed the former socialist welfare housing systems into large–scale residential compounds (or gated communities) and introduced property ownership among citizens. Unequal access to property assets further widened the gap between the wealthy and poor, as well as increasing the divide between urban and rural China. The production and consumption of urban housing progressively reflected the new social stratification in China: social classes regrouped in similar neighborhoods, whether rich or common, and each was identified by their distinctive economic and cultural consumption practices (Tombs 2014; Graezer Bideau and Pagani 2019; Pow 2009).

Today, the promotion of economy through land leases and urban planning is an essential tool for local governments. Cities’ master plans are used to implement long–term policies that legitimize new modes of developmental governance (creation of Special Economic Zones (SEZ), Central Business Districts (CBD), High–Tech zones, etc). Mainly run by Red Engineers, these new urban

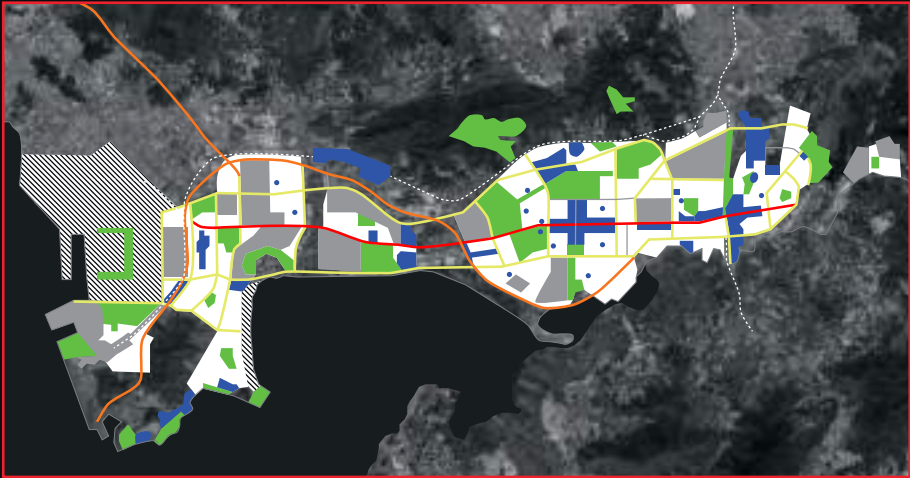

PARK
  INDUSTRIAL
  COMMERCIAL
  RESIDENTIAL
  PORT/AIRPORT

URBAN ARTERIAL
  MAJOR URBAN ROAD
  EXPRESSWAY
  NATIONAL RAILWAY
  SHENNAN AVENUE

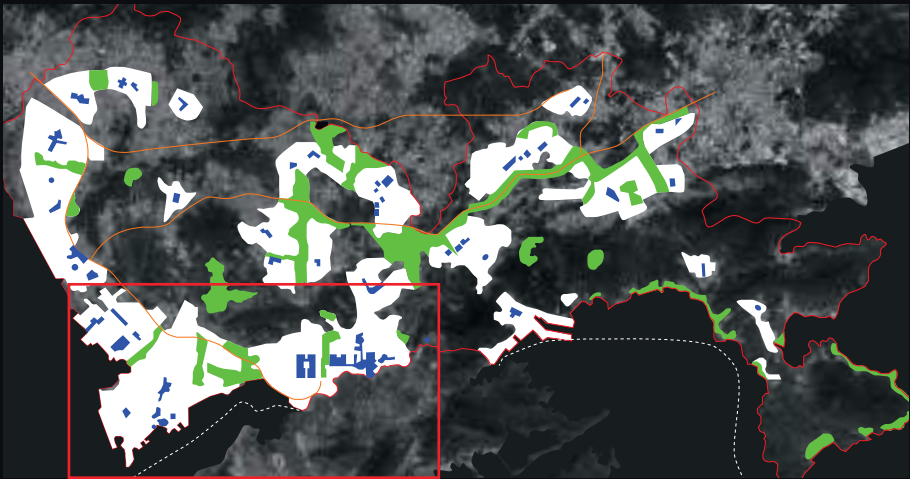

PARK
  URBANIZED TERRITORY
  EXPRESSWAY
  COMMUNITY CENTRE
  SEA

TOP: The 1986 Plan of Shenzhen, encompassing the Shenzhen Economic Zone (SEZ).

BOTTOM: The 1996-2010 Plan of Shenzhen, adapted from Shenzhen Urban Planning & Land Administration Bureau (2000) Shenzhen Comprehensive Plan (1996-2010).

development plans are presented as scientific, rational and sustainable. They are implemented by detailed plans (详细规划 *xingxi guihua*) which pragmatically control the urban development by incorporating cellular urbanism with mixed functions in order to face head on societal change in China.

#### PLANIFICATION OF SHENZHEN:

##### AN EXPERIMENTAL CASE STUDY FROM THE 1980S

Shenzhen was one of the first experimental sites in China's economic reforms. As a pilot project, the Shenzhen Special Economic Zone was initiated to combine technology, modern governance and foreign experience, and was located in a corridor between Hong-Kong and mainland China. Shenzhen is therefore a relevant example of how capitalist urban development practices were adapted to a specific context where land management was highly controlled by central government (Ng and Tang 2004). As Zacharias and Tang demonstrated (2010), Shenzhen experimented with urban planning reform as a vehicle for transforming the management of land resources, and the restructuring of its local economy from fishing villages to high-tech industries, with a low-cost workforce in order to become the major hub for trans-shipping and logistics command in the Pearl River Delta area. The uniqueness of Shenzhen is also due to the rapid growth of its population, rising from 30 thousand to over 10 million inhabitants over the past 40 years. How did this transformation take place? How could the local government put into practice a set of innovative urban planning policies in a transitional economy? And even more importantly, how did Shenzhen succeed in adapting its development to such rapid changes at a political, economic and social level? Local government had to follow the instigator of the reform era, Deng Xiaoping, who claimed: "Central Government has no resources and so you [the SEZs] have to do it on your own to 'find a way out.'" (Shao 1998 quoted by Ng 2003, 431).

Urban growth and spatial development materialized in three waves. The first master plan in 1986, the Shenzhen comprehensive Development Draft plan, included allocations for major infrastructure and a project for city expansion. Local government acquired rural lands through an administrative allocation process, and launched a set of clusters (park, industrial, commercial, residential and port/airport) alongside the central corridor of Shennan Avenue. The design of this plan was to break with the former core-periphery and monocentric morphology of Chinese cities from the Imperial era by implementing a "clustered linear planning principle" (带状组团 *dai zhuang zu tuan*).

Influenced by former socialist master plans in China, Shennan Avenue became Shenzhen's central axis and a symbol of the economic reforms introduced by Deng Xiaoping, as Chang'an Avenue was the symbol of the new era launched by Mao Zedong in the 1950s. This horizontal axis was gradually flanked by large compounds which recalled the cellular urbanism previously experienced in Beijing and many Chinese cities. Until the 1990s, the development of Shenzhen followed this spatial principle that established a pattern of grids composed of working districts, residential areas and green spaces, incorporating mainly dormitory



SHENZHEN CIVIC CENTER, SHENZHEN'S 40TH ANNIVERSARY LIGHT SHOW, JUNE 30, 2018.

accommodation associated with factories to host major waves of immigration. This resulted in rather homogeneous and standardized urban designs with an uncontrolled development of the phenomenon of urban villages—pockets of low rise housing with a high density of poor and transient residents surrounded by skyscrapers and mobility infrastructure—in the core city (Ai 2014).

Later, this linear principle was extended to a larger planning area. The 1996 Comprehensive master plan proposed multiplying such “axis structures” in order to better connect newly developed areas such as Bao’an and Longgang to the central corridor of Shenzhen. This model of city networking was adapted to absorb unplanned developments which basically resulted from inefficient use of land resources and investment funds. New development projects sought to bring diversity to the visual skyline, incorporate cultural facilities (exhibition centers, libraries, opera houses, children’s palaces, government buildings, etc.) and shopping malls, and to redefine green areas. Among them, one finds the Shenzhen Civic center, built in the shape of a former Imperial pavilion, which lies at the intersection of the north–south axis and the east–west axis. This oversized governmental building, surrounded by an area of skyscrapers and a green belt, seeks to demonstrate the modernity of Shenzhen’s SEZ. References to Manhattan and the European garden featuring iconic buildings reflect the rapid transformation of rural villages into an international city.

Specific clusters were also built, such as the Overseas Chinese Town (OCT), a theme park based around copies of iconic international buildings, hotels and residential areas. The new Central Business District of Luohuo Center was erected on the site of a former historical town, and a train connection to Hong Kong that comprises commercial, residential and industrial uses. Later on, new urban districts developed in its west, including industrial development projects (high–tech and science parks) and the University of Shenzhen (Futian, Nanshan and Shekou). Its east also saw the addition of tourism–based developments, including beaches, OCT East and a commercial port (Yantian). All these constructions contributed to the development of a diverse array of urban forms, ranging from distant fishing villages to residential high–rises, from traditional markets to contemporary shopping malls, and from traditional work–units to privileged gated–community compounds.

This model of city networking is today considered a first step towards a transition to high–tech industrial development in Shenzhen. Urban planning is an engine for future growth that combines in its design the integration of socioeconomic and spatial planning. This step forward contains the idea of upgrading the city to make Shenzhen an internationally significant locale.

In the 2000s, Shenzhen’s comprehensive plan was revised (2007–2020) alongside an urban development strategy (2030) which relied on a polycentric model in order to face decades of rapid urban growth and its related problems (land resources, shortage of water, population growth and environmental issues), and to effectively promote the gradual transition of industry from production and

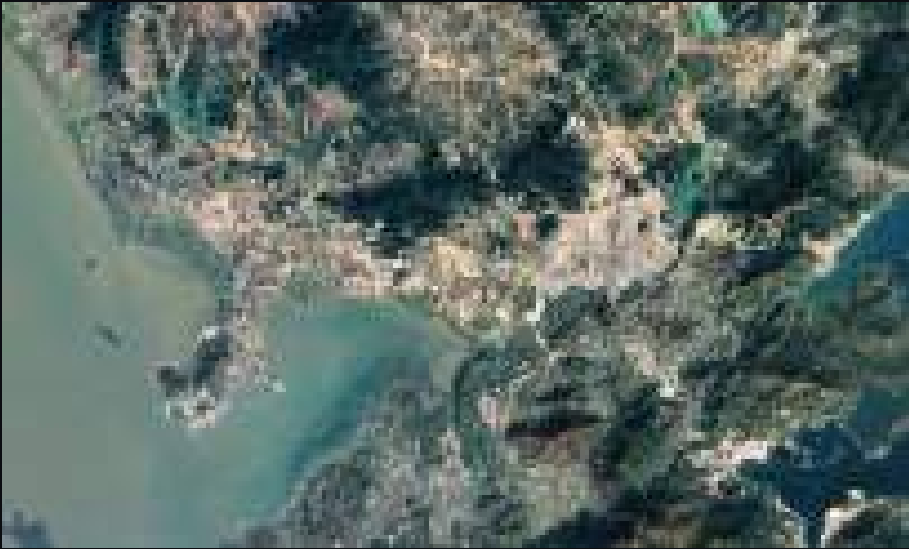

SHENZHEN 1984

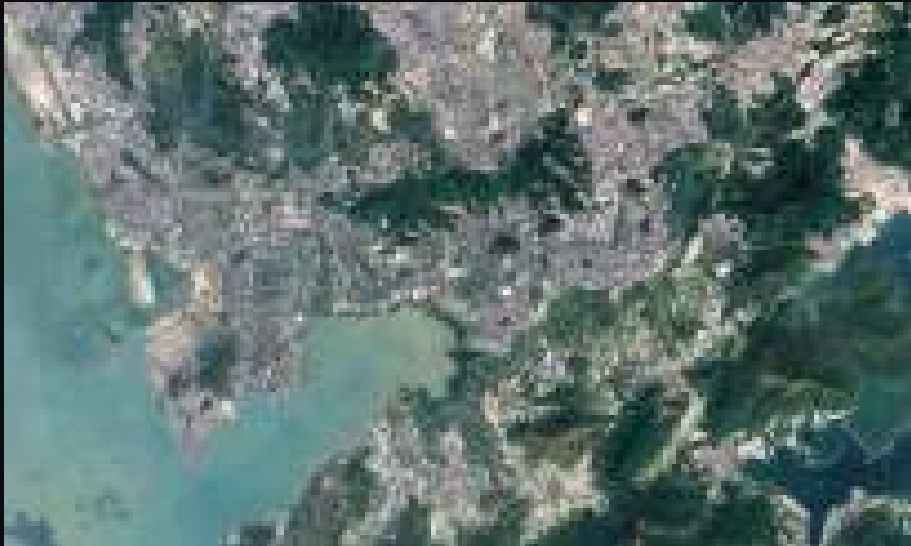

SHENZHEN 2018

SHENZHEN 1984-2018 SATELLITE TIMELAPSE:  
POPULATION GROWTH 1985-2015: 6,040%  
(1955: 5,000 PEOPLE; 1985: 175,000; 2015: 10.7 MILLION)

manufacturing to services and high-tech industries. The 2030 strategy seeks to reorganize the entire PRD region into five complementary sub-regions (Shenzhen, Hong Kong, Dongguan, Guangzhou and Huizhou) with local centers that include office buildings, shopping, housing, and transportation interchange facilities. The goal here is to produce a coherent development pattern that comprises inner and outer districts interconnected by mobility infrastructure (road, rail, metro and maritime), alongside the transformation of the Shenzhen social fabric. In this regard, local government has intervened in the development of former industrial zones or urban villages to implement neighborhood regeneration processes in order to fine-tune and adapt the economy's dynamics (Deng, Fu and Sun 2018). This has resulted in multiple-use buildings incorporating apartments, hotels, shops, offices and start-up businesses, accommodating large numbers of people and residents and fostering microscale creative economies. The Vanke Cloud City in Shenzhen is an illustrative example of such urban developments that promote a new lifestyle connected to business opportunities.

Urban villages with communities of farmers and fishermen were more difficult to integrate into the contemporary city, and the collective ownership of their lands posed challenges to the Shenzhen planners (Bach 2010) since local government needed to acquire parcels of land preceding urban development. This coherent urban planning strategy did not prevent social difference being expressed through district location. Indeed, the rapid building process in Shenzhen resulted in relatively homogeneous, good quality housing occupied by middle-class engineers and blue-collar workers that contrasts sharply with urban villages which are mainly inhabited by communities of floating populations, migrant workers and the poor (Eric 2017; O'Donnell, Wong & Bach 2017).

#### CONCLUSION: A NEW MODULE FOR CHINESE NEW TOWN?

Shenzhen is today considered an urban laboratory for all of China. The main interest of the city has always been the large scale "experimental ground" (Ng 2003: 431). This urban pilot demonstrates that it is now possible to effectively plan such large-scale developments. Shenzhen also demonstrates that not only architectural, technological and digital innovations but also social innovations can be introduced under "socialism with Chinese characteristics." Flexible regulations towards *hukou* (户口) have generated social transformations in the urban fabric where, for instance, farmers were transformed into owners and residents of high-quality housing.

Urban planners also witnessed a change of paradigm: they are no longer considered mere technicians assisting with the planning of economic transitions as they were in the early phases of Shenzhen development during the 1980s. Instead they became the central strategists who masterminded a new vision for Shenzhen as a world-class city (Ng and Tang 2004). These urban experimentations were globally successful and are regarded as models to be reproduced and pursued in other cities with a high potential of innovation, technological and economic development, such as the Chengdu-Chongqing cluster in Western China or the Yangtze Mid-River Delta cluster in Central



SHENZHEN ROOFTOPS AND URBAN VILLAGE.  
Photo (top): Dennis de Bel

West China. But the experience of Shenzhen was not without a measure of failure, mainly due to local constraints such as the underestimation of population growth, and the shortage of land for development. Technical support and new policy-making rules definitively assisted the local government with their constant adaptation of the management of Shenzhen's spatial development, in order to meet the changing needs of the population. This included frequent shifts of housing and neighborhoods, longer commutes due to the expansion of the city, regular use of public spaces for recreational activities or simply shopping and the desire to develop a sense of local community, well-being and quality of life.

In summary, Shenzhen demonstrated a process of local government's incessant negotiation with spatial practices: the rapid transformation of the urban fabric needed to gradually adapt its urban forms and modules to the current situation. The study of a city's urban planning reveals such real-time adjustments. This is particularly true with the informality of urban villages and the urban regeneration process allowing temporary arrangements, and a gradual approach to problem solving (Wang, Wang and Wu 2009). The Shenzhen example reveals a flexible attitude that balanced public and private interests to develop an efficient control mechanism for urban growth. According to a recent article in the South China Morning Post,<sup>3</sup> the recent administrative and economic reforms promoting Shenzhen as a "pilot demonstration area of socialism with Chinese characteristics" reflects a pragmatic approach. "Learn as you go" is still the motto for constant adaptation to current conditions to find solutions that work (Schoon 2014). The Greater Bay Area strategy unveiled by Xi Jinping in 2019 aims specifically to achieve high-quality growth focused on innovation development. It officially promotes Shenzhen as a model for the future development of mainland Chinese cities (instead of Hong Kong in the past).

#### REFERENCES:

- Ai, Stefan, ed. 2014. *Villages in the City: A Guide to South China's Informal Settlements*. Hong Kong: Hong Kong University Press.
- Andreas, Joel. 2009. *Rise of the Red Engineers: The Cultural Revolution and the Origins of China's New Class*. Stanford: Stanford University Press.
- Bach, Jonathan. 2010. "'They Came in Peasants and Leave Citizens': Urban Villages and the Making of Shenzhen, China." *Cultural Anthropology*, 25 (3): 421–458.
- Deng, Yu, Fu Bojie and Sun, Chuanzhun. 2018. "Effects of Urban Planning in Guiding Urban Growth: Evidence from Shenzhen, China." *Cities*, 83: 118–128.
- Florence, Eric. 2017. "How to Be a Shenzheners: Representations of Migrant Labor in Shenzhen's Second Decade." In *Learning from Shenzhen: China's Post Mao Experiment from Special Zone to Model City*. Chicago: The University of Chicago Press.
- Graezer Bideau, Florence and Pagani, Anna. 2019. "Shaping Urbanity: Politics and Narratives." In *The City after Chinese New Towns: Spaces and*

<sup>3</sup> "Why China Is Looking to Shenzhen—and not Hong Kong—to Reinvent its Economic Future," by Josephine Ma, Catherine Wong and Echo Xie, and published July 31, 2019.



COMPUTER HARDWARE RESELLERS CHILLING IN HUAQIANGBEI, THE LARGEST ELECTRONICS MARKET IN THE WORLD IN SHENZHEN, CHINA.  
Photo: Dennis de Bel

- Imaginaires from Contemporary Urban China*, edited by Michel Bonino, 78–96. Basel: Birkhäuser.
- Hsing, You-Tien. 2010. *The Great Urban Transformation: Politics of Land and Property in China*. Oxford: Oxford University Press.
- Liang, Samuel, Y. 2014. *Remaking China's Great Cities: Space and Culture in Urban Housing, Renewal, and Expansion*. London: Routledge.
- Lu, Duanfang. 2006. "Travelling Urban Form: The Neighbourhood Unit in China." *Planning Perspectives*, 21 (4): 368–392.
- Ng, Mee Kam. 2003. "Shenzhen," *Cities*, 20 (6): 429–441.
- Ng, Mee Kam and Tang, Wing-Shing. 2004. "Theorising Urban Planning in a Transitional Economy: The Case of Shenzhen, People's Republic of China." *The Town Planning Review*, 75 (2): 173–203.
- O'Donnel, Mary Anne, Wong, Winnie & Bach, Jonathan, eds 2017. *Learning from Shenzhen: China's Post Mao Experiment from Special Zone to Model City*. Chicago: The University of Chicago Press.
- Pow Choon-Piew. 2009. *Gated Communities in China: Class, Privilege and the Moral Politics of the Good Life*. London: Routledge.
- Schoon, Sonia. 2014. "Chinese Strategies of Experimental Governance: The Underlying Forces Influencing Urban Restructuring in the Pearl River Delta." *Cities*, 41: 194–199.
- Shatzman Steinhardt, Nancy. 1990. *Chinese Imperial City Planning*. Honolulu: University of Hawaii Press.
- Tomba, Luigi. 2014. *The Governmental Next Door: Neighborhood Politics in Urban China*. Ithaca: Cornell University Press.
- Wang, Ya Ping, Wang, Yangling and Wu Jiansheng. 2009. "Urbanization and Informal Development in China: Urban Villages in Shenzhen." *International Journal of Urban and Regional Research*, 33 (4): 957–973.
- Wu, Hung. 2005. *Remaking Beijing: Tiananmen Square and the Creation of a Political Space*. Chicago: The University of Chicago Press.
- Zacharias, John and Tang, Yuanzhou. 2010. "Restructuring and Repositioning Shenzhen, China's New Mega city." *Progress in Planning*, 73 : 209–249.
- Zhu, Jianfei. 2009. *Architecture of Modern China: A Historical Critique*. Abingdon: Routledge.





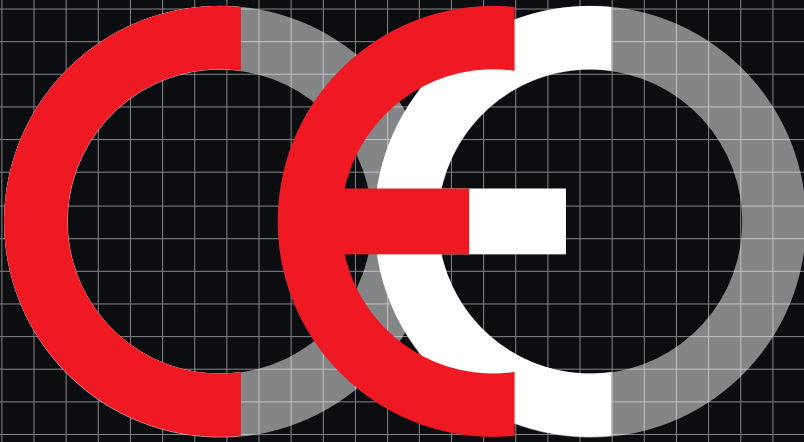

#### CONFORMITÉ EUROPÉENNE VS CHINA EXPORT.

The Conformité Européenne (CE) mark (white) is a common sight on products in North America and Europe. However the China Export mark (red) and CE mark are easily confused, understandable given they appear almost identical. The China Export Mark means the product was manufactured in China. No registration, testing, or auditing is required in order to use it. The mark can be used arbitrarily by Chinese manufacturers.

# PRODUCING STANDARDIZATION: CHINESE BLOCKS IN NETWORKS

---

如何创造标准化：国际网络中的中国版块 | Marc Laperrouza

---

The gravity center of the global economy is tilting back towards Asia. Central to this shift are regional and global production networks to which Chinese companies increasingly add value, relying less and less on exports of semi-manufactured and finished goods. In parallel, deployment of large scale infrastructure and service provision at the domestic and international level comprises both physical and digital components with massive amounts of data flowing along telecommunication networks, electric grids, shipping lines and railway routes. This chapter discusses how standardization has enabled the participation of Chinese companies in global value chains (GVCs) and how the production of standards is now used as a strategy to drive them. It argues that the Belt and Road Initiative (BRI) can serve as a vehicle to deploy Chinese standards across borders, raising important questions related to economic and technological sovereignty and security.

## 1. RE-EMERGENCE OF ASIA/CHINA AS CENTERPIECE IN THE GLOBAL ECONOMY

CHINA IN GLOBAL ECONOMIC HISTORY:

RE-EMERGENCE RATHER THAN EMERGENCE

For almost as long as history books can recall, China has enjoyed economic prominence on at least a regional level, with innovation capacity and regional dominance. However, the weight of China (and India) in the world economy changed drastically during the second half of the 19th century. Between 1840 and 1950, the country's GDP dropped from a third to a twentieth of the world's total, and per capita income fell while rising three-fold in Japan, four-fold in Europe and eight-fold in the United States (Maddison 2007). It would take some radical domestic economic reforms for the Chinese economy to put an end to this 150-year period, during which the country stood at the margins of the world economy, and to feature again prominently in GDP tables.

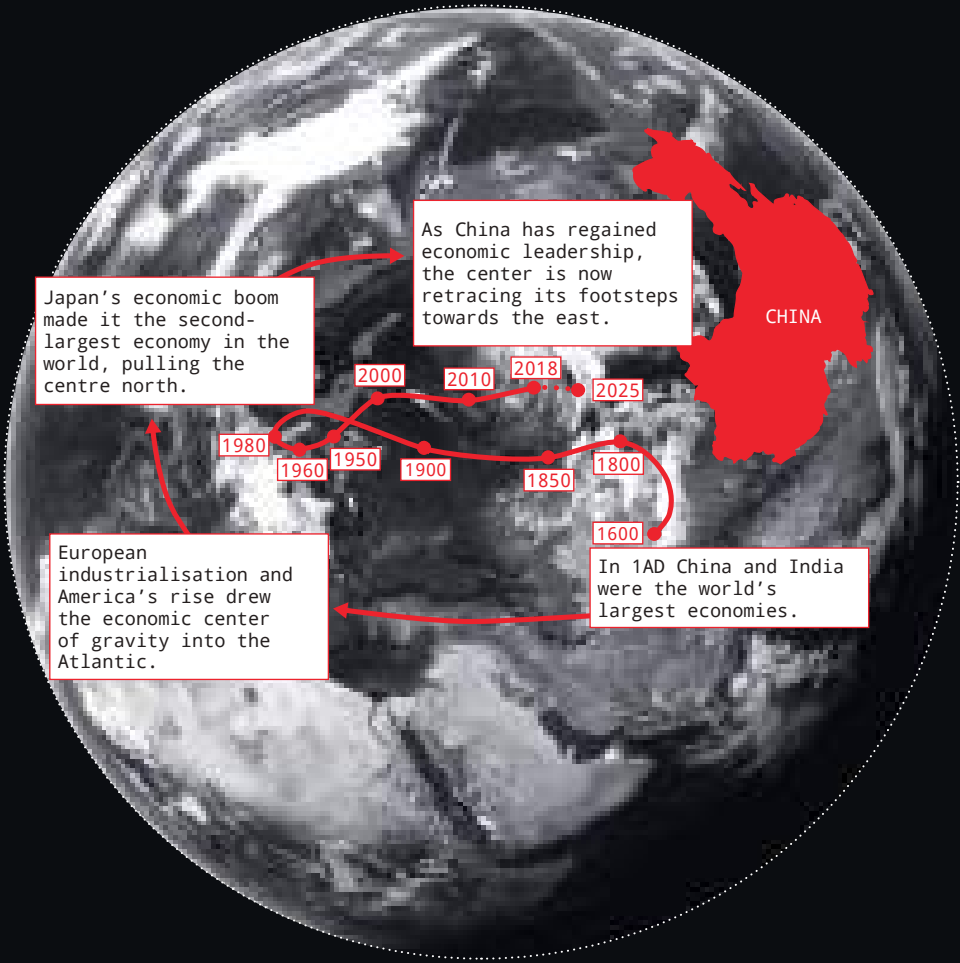

**THE WORLD'S ECONOMIC CENTER OF GRAVITY.**

Often dominant at home, Chinese manufacturers seldom maintain the lead in host markets. The economic center of the globe is calculated using an average of countries' locations weighted by their GDP.

Ushered in by Deng Xiaoping, the open door policy reconnected the country with the global economy, initially with lightweight industries, later with heavy industries and electronics, and now increasingly with critical infrastructures and services.

The shift of economic gravity back toward the East should not be attributed solely to China. Japan's post-war recovery, followed by the emergence of the four "little dragons",<sup>1</sup> laid the ground for reversing the trend of Western-centric economic powers. These newcomers developed largely thanks to their connection to other economies, at times in the vicinity, at times on the other side of the world. The permanent movement of production means from Japan to other Asian economies created over time a large and intricate regional production network. Such networks proved to be very handy when the Chinese economy opened up again to trade and started to look for ways to participate in global production activities.

Another factor contributing to this shift was the fact that growth rates in Europe and, to a certain extent the United States, started to slow down. Whereas the world economy saw a succession of European empires dominate economic history from the 15th to the early 20th centuries, competition in the first half of the 21st century has taken place between Beijing and Washington. For the past 50 years, the United States, Europe and Japan have dominated exports in information and communication technologies (ICT), embedding many homegrown standards in products and services used throughout the world (e.g., GPS, GSM, VGA, etc.). China's economic development and technological progress in particular fields (telecommunications, machine learning, etc.), coupled with the sheer size of its economy has started to threaten US economic and technological dominance. Whereas some already point to a new Cold (technology) War, one should keep in mind that the level of interconnection between economies is unprecedented in world economic history and that most countries (and consumers) benefit from such interdependency.

#### A LOT OF PLANNING AND GOOD TIMING

For all its political leadership, planning and implementation capability, the Chinese government also owes its impressive economic turnaround to a number of exogenous factors. The liberal agenda championed by the United States and the United Kingdom during the 1980s paved the way for deregulation across the world. As a result, the flow of goods, capital and technologies increased notably thanks to an international framework conducive to exchange and development. Reduction of tariffs on the trade of IT products<sup>2</sup> in the framework of the Uruguay Round was accompanied by attempts to address the growing service component through an agreement on basic telecommunications services, introducing among other things the concept of technological neutrality. In effect, governments were recognizing the importance of innovation, intellectual property and

1 South Korea, Singapore, Taiwan and Hong Kong.

2 The Information Technology Agreement (ITA) was concluded by 29 participants at the Singapore Ministerial Conference in December 1996.

TECHNOLOGY		MARKET SHARE IN CHINA %	MARKET SHARE IN THE REST OF THE WORLD %	FIRST-TIER COMPONENTS FROM CHINESE SUPPLIERS %
LEADING LOCAL PLAYERS WITH LOCAL CONTENTS	SOLAR PANELS	100	50	70-85
	HIGH-SPEED RAIL	100	5	75-90
	DIGITAL PAYMENTS	95	10	>85
LEADING LOCAL PLAYERS WITH FOREIGN CONTENTS	WIND TURBINES	80	5	60-75
	ELECTRIC VEHICLES	95	5	60-75
	CARGO SHIPS	90	45	40-50
	AGRICULTURAL MACHINERY	88	19	60-80
	SMART-PHONES	85	25	35-50
	CLOUD SERVICES	70	8	<35
	ROBOTICS	50	15	25-45
LAGGING LOCAL PLAYERS	SEMI-CONDUCTORS	5	5	<10
	AIRCRAFT	<5	<1	<20

CHINESE PRODUCERS

NON-CHINESE PRODUCERS

the flow of technology for economic growth.<sup>3</sup> Technological developments and trade-related measures significantly lowered transaction costs. This made it even easier to scatter production facilities across the world in search of the lowest production costs (and working standards...). In other words, China's economic re-emergence coincided with, and benefited from, a number of factors that brought economies closer than they had ever been.

#### FROM SHIPS TO CHIPS?

The phenomenal growth of international trade and sophisticated intrication of suppliers, contract manufacturers and other actors in the supply chain is due in large part to technology and trade agreements. It probably owes as much, if not more, to an innovation in logistics. The fragmentation of production and the ensuing acceleration of trade has indeed been made possible by the standardization of containers initiated in the United States at the end of the 1950s (Levinson 2006). The standardization was actually an attempt to regain competitiveness for US ports by simplifying logistics, reducing overall transport time and, in the end, the total cost.

Fast-forward 50 years and one could observe a similar pattern of standardization in the field of telecommunication manufacturing. Companies like MediaTek, a Taiwanese chipset manufacturer in search of competitive advantage, transformed some parts of the handset manufacturing business by offering turnkey solutions. This opened the door to Chinese companies with limited technical know-how but a good understanding of particular markets to match demand and offer, in a cost-effective manner, something that would have been totally impossible without the standardization of components throughout the value chain.

Being able to sell globally operable mobile phones while having limited technical knowledge wasn't a given. In fact, until not so long ago a European traveler crossing the Atlantic would not have been able to use her mobile phone in the United States as manufacturers (and operators) on both sides of the ocean were battling to impose their homegrown telecommunication standards. The telecommunication industry clearly illustrates the importance of standards in economic growth and, to a certain extent, why they have become so central to governments intent on ensuring technological dominance for their domestic industries and companies.

In the field of telecommunications, the Chinese government had been extremely keen at the turn of the century to promote TD-SCDMA, a "homegrown" standard for 3G.<sup>4</sup> Its enthusiasm extended to China Mobile, assigning its deployment as a way to find an alternative to European or American standards.

<sup>3</sup> The agreement on Trade-Related Aspects of Intellectual Property Rights (TRIPS) enshrined IP into the trading system in 1995.

<sup>4</sup> Time Division Synchronous Code Division Multiple Access (TD-SCDMA) was jointly developed by the Chinese Academy of Telecommunications Technology, Datang Telecom and Siemens.

2000

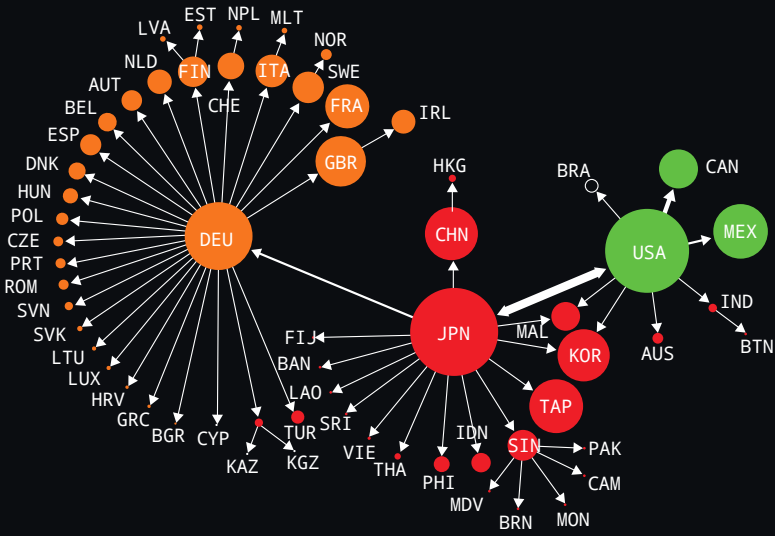

2017

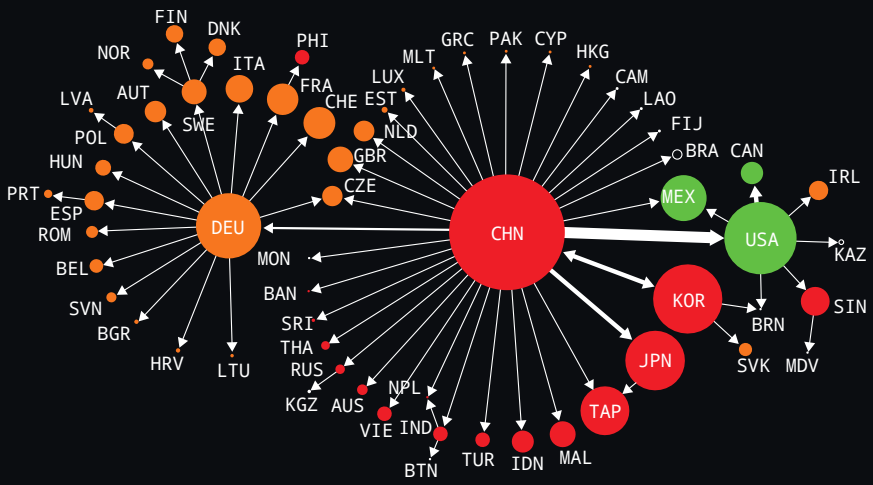

SUPPLY HUBS OF TRADE IN VALUE-ADDED TO VARIOUS NETWORKS IN THE ICT SECTOR (TRADITIONAL TRADE NETWORKS).

In that particular case, the attempt failed both domestically and internationally as the standard did not offer the required technological maturity. As we will see later, it was just a matter of time before a Chinese company would be ready to offer a telecommunication standard with the potential to be deployed globally.

The deployment of standards and, more importantly, the dominance of standards is not an easy feat. One can differentiate *de jure* standards, which are imposed by the government or standardization bodies, and *de facto* standards which are imposed by the market. *De jure* standards can be powerful tools for the implementation of industrial policies orchestrated by the government, and China's *de jure* standardization efforts have been relentless at the domestic level. For the past two decades, few sectors have been spared as an estimated 150,000 standards were adopted in an attempt to regulate economic agents at all levels (national, provincial and local).<sup>5</sup> In 2018, and alongside a swarm of other initiatives aimed at positioning China among the front-runners of innovation such as "Made in China 2025",<sup>6</sup> the government initiated the China Standard 2035 policy. This does not mean that market-driven standards do not exist in China. In fact, similar to what has been witnessed in other areas of economic reforms, the government has often used a dual strategy by letting competition in the market emerge while maintaining an oversight.

Not surprisingly, China's standardization drive does not stop at its borders, nor does it leave rival economies impervious. The propensity of the Chinese government to play the standardization card is increasingly raising concerns abroad. Breznitz and Murphree (2013) have argued that "the main challenge China poses in standardization is in establishing new norms, particularly the advancement of a cheap royalty option to the holders of standards—essential Intellectual Property Rights (IPR)."<sup>7</sup> They also pointed to the increased skill and sophistication in global standards organizations. Chinese companies (e.g., Huawei) understood this early on, and in the late 1990s began to increase their presence and activity (e.g., commission chairing) in different international telecommunication forums such as ITU and 3GPP. Lastly, the authors have highlighted the role of government in the standardization process—as opposed to more voluntary and market-based approaches in the United States. Standards can indeed be used both as a way to ensure easy dissemination and interconnection of technologies and as a tool for protectionism. One needs to look no further than electric plugs in European countries to grasp how standardization can betray inward—rather than outward—looking strategies.

5 One obviously needs to differentiate technological and non-technological standards (e.g., safety standards). In particular since the former usually come with network and lock-in effects.

6 Made in China 2025 is a strategic plan at the national level aimed at turning China into a major manufacturing power over a ten-year period. It epitomizes the Chinese government's ambition to move up the value chain.

7 By creating competing standards for similar technologies, the idea is to push foreign standard alliances to lower their rates.

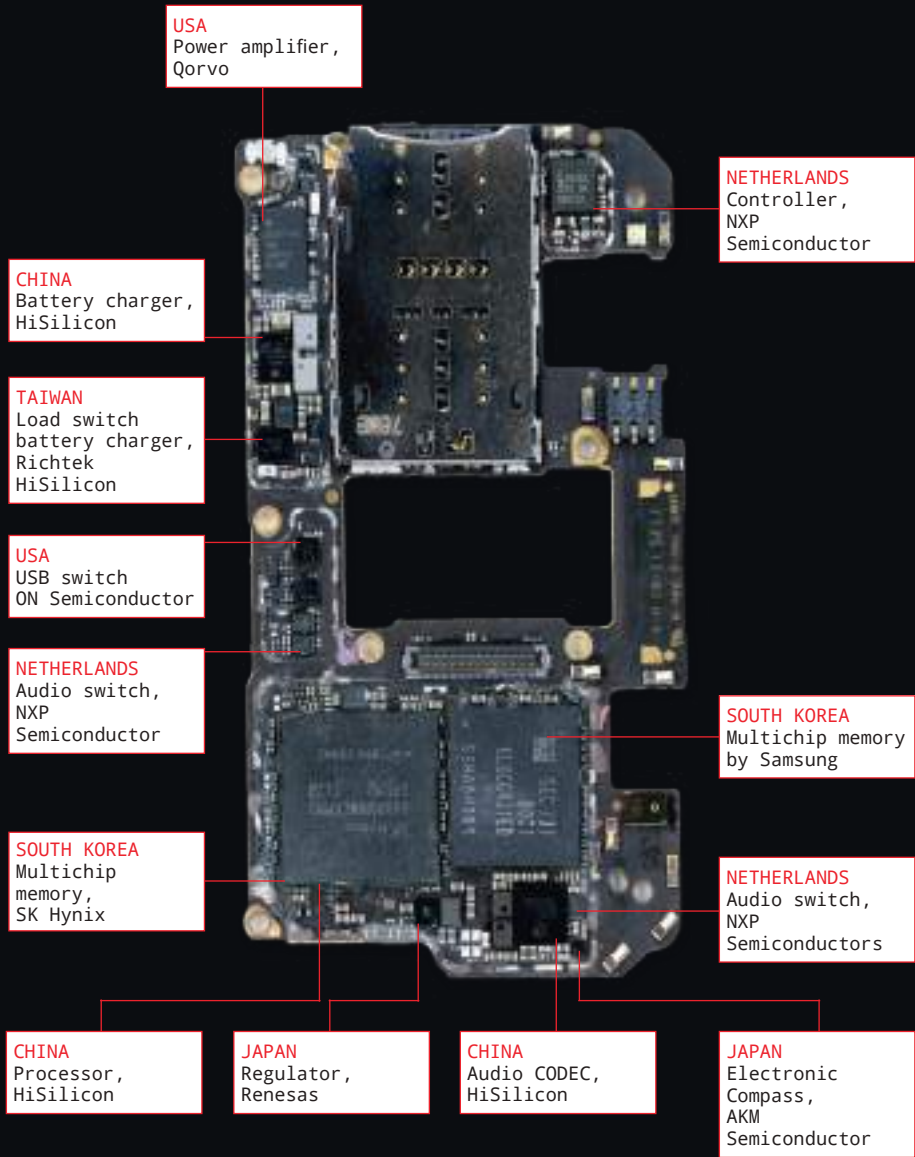

**CHINA™ INSIDE**

Electronic components originate from multiple countries before being assembled in China.

The jury is still out as to whether China's standardization strategy has really paid off. Whereas Chinese technology firms tend to dominate the Chinese market or act as first-tier suppliers in many industries, their market share in the rest of the world remains below 20% in all but two industries, namely solar panels and cargo ships (Woetzel et al. 2019).

In summary, the Chinese economy has benefited from the alignment of trade opening, standardization and development in ICT to engineer one of the most impressive economic growth periods observed in history. However, its model of economic development, based on technological catch up and low added-value manufacturing activities (the low-hanging fruit of globalization), has reached its limits. In fact, Chinese companies have now understood the need to strengthen their position in global value chains and to capture higher returns from participation in global trade.

## 2. GLOBAL VALUE CHAINS, STANDARDS AND UPGRADING

One way governments "measure" China's place in today's world economy is through their trade deficit with the factory of the world. Measuring goods at the border actually offers a simplistic view of the reality of international trade and supply chains. Take, for instance, an iPhone entering the United States. While each phone adds USD300–400 to the US trade deficit with China, the actual value-added by firms based in China remains extremely low (e.g., labor costs below USD10 for the assembly of an iPhone 4) and is mostly captured by foreign contract manufacturers like Foxconn (Dedrick et al. 2010). Outsourcing of production has placed the Chinese economy at the center of Asia's regional production network but control still largely rests in other hands.

































The trade deficit is in fact a trade deficit with all other countries sending intermediate goods for assembly in China. Crude trade measurement systems like the balance of trade are being replaced by input and output tables which give a much more precise and correct view of the reality of added-value and, in the end, a more nuanced picture of trade deficits.

### MOVING UP GLOBAL VALUE CHAINS

A way of looking at how Chinese companies climb up the technology food chain is to look at the type and value of components originating from China found in technological devices and their evolution over the years. In high-end technology products, foreign firms still account for a large part of added-value but in products further away from the technology frontier, Chinese firms tend to capture an increasingly higher value.

The efforts of companies to grab more value is meeting the Chinese government's strong push for indigenous innovation. In other words, top-down innovation policies are meeting enhanced bottom-up innovation capacity. That said, the "ideal" alignment of government and industry interest may not automatically lead to actual upgrading. In a recent study, the IMF found that the relationship between

0-20  80-100

AREAS/SECTORS	TECHNOLOGIES REVIEWED	SHARE USING GLOBAL STANDARD	SHARE THAT HAS LOCAL PROVIDER	SHARE WHERE CHINESE COMPANIES TECHNICALLY PROVIDE BETTER THAN OR ON PAR WITH GLOBAL LEADER
BASIC MATERIALS ▪ MINING ▪ STEEL	7			
CHEMICALS ▪ OIL & GAS ▪ COMMODITY & SPECIALTY CHEMICALS ▪ TEXTILES	12			
COMPONENTS ▪ DISPLAY ▪ INTEGRATED CIRCUITS	8			
ELECTRIC VEHICLES ▪ BATTERY ELECTRIC VEHICLES ▪ PLUG-IN HYBRID ELECTRIC VEHICLES (PHEVS)	7			
TRANSPORTATION ▪ HIGH-SPEED RAIL ▪ MARINES	10			
CONSUMER ELECTRONICS AND INTERNET ▪ CONSUMER ELECTRONICS ▪ DIGITAL PAYMENTS ▪ DRONES	11			
EQUIPMENT ▪ SURGICAL ROBOTS ▪ INDUSTRIAL ROBOTS	4			
PHARMACEUTICALS AND BIOTECH ▪ SMALL-MOLECULE DRUGS ▪ BIOMOLECULE DRUGS	6			
ARTIFICIAL INTELLIGENCE ▪ SPEECH RECOGNITION ▪ FACIAL RECOGNITION ▪ AUTONOMOUS DRIVING	5			
NEXT-GENERATION TECHNOLOGIES ▪ QUANTUM TECHNOLOGY ▪ 5G ▪ SPACE	8			
GENOMICS ▪ GENOTYPING ▪ GENE SEQUENCING ▪ GENE EDITING	3			
TOTAL	81	>90%	60-80%	40-60%

CHINA™ INSIDE

When it comes to standardization, the number of sectors in which Chinese companies lead remains small.

upstreamness in GVCs and economic development is not straightforward. While financial and business services tend to be upstream and high in added-value, the link is less clear in manufacturing (IMF 2019). In other words, economic and political actors alike will need to keep experimenting as economic structure and production networks evolve. One cannot fail to notice how China's position in global production networks has changed since the turn of the century, both from a supply and demand perspective and in both simple and complex networks.

#### TECHNOLOGY, GLOBAL VALUE CHAINS AND STANDARDIZATION

Woetzel et al. (2019) have looked at the extent to which China's technology value chains are integrated globally. They found that in 81 technologies in 11 categories more than 90% of technologies used in China follow global standards. In a further analysis of comparable standards, they found that "Chinese suppliers may be able to achieve performance on a par with, or better than, global suppliers in 40 to 60 percent of the technologies studied." In addition, in emerging technologies (e.g., 5G and artificial intelligence) "where a global standard may not yet have been defined, China has begun to make headway."

Standardization may again serve as a guiding hand to ensure participation in the global economy. Nadvi (2008) has argued that compliance with international standards is now a *sine qua non* for entry into globalized production networks. Similarly, Inomata and Taglioni (2019) found that "standardization through breaking production into modules with a high degree of functional autonomy (limited mutual interference between modules) can dramatically reduce the amount of research and development (R&D), learning by doing, and the number of complementary skills needed to produce a good. This greatly increases opportunities for developing country firms to participate in formerly capital-intensive industries through reducing entry costs into global value chains."

Such eased access to technology can also flood the market with similar products. In addition, the "protectionism" that comes with standardization can also act as a disincentive to innovate, delaying the reality of market competition. In other words, the Chinese government and companies will need to find an equilibrium between rule-maker and rule-taker. There is little doubt that the "assembly economy" model of development based on cheap labor and low productivity has run its course. Pressured by rising labor costs, manufacturing companies are already turning to automation, shedding in the process millions of jobs. Some of the more sophisticated companies are already investing massively in research and development (R&D) to (finally) capture the fruits of globalization. As we will see with the case of Huawei and 5G, such a journey is by no means easy as more and more governments seem to have re-discovered the strategic and geopolitical importance of deploying homegrown standards across the world.

The Chinese government and companies have notably upped their game in the fields of telecommunications. They are already setting their sights on the next technology frontier. How countries and companies regulate AI may offer the next data point as to whether and to what extent the Chinese government and

INTERNATIONAL PATENT APPLICATIONS  
PCT '000

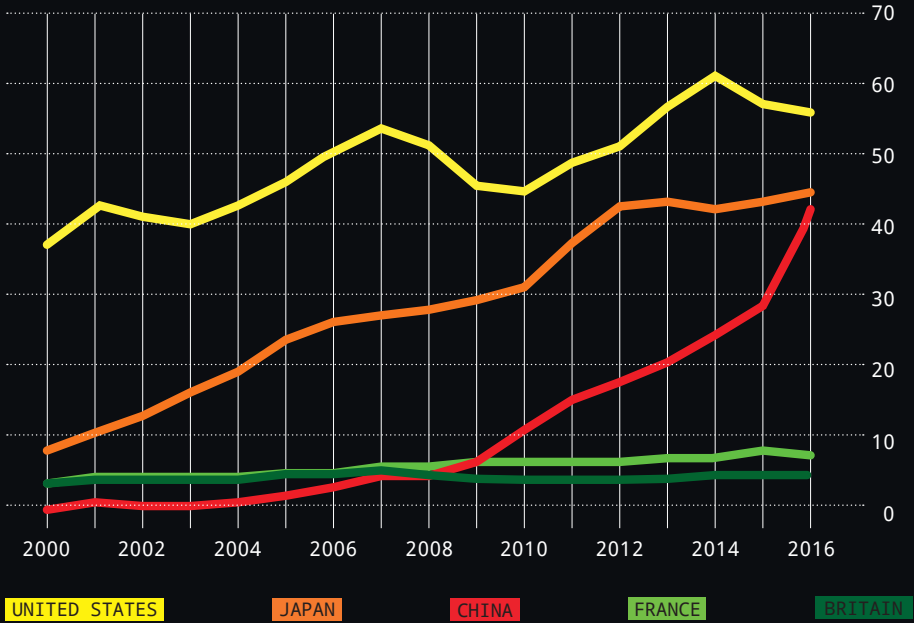

CHINA'S INTERNATIONAL PATENT APPLICATIONS  
BY CITY, %, 2016

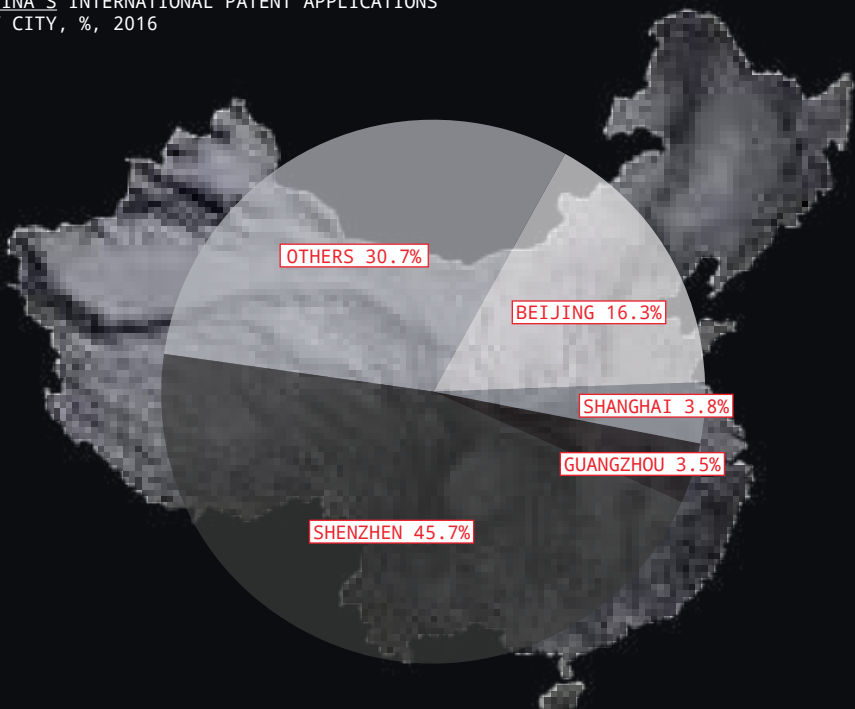

ICT WEIGHS HEAVILY IN CHINA'S INTERNATIONAL PATENTING ACTIVITY.

companies orchestrate their transition from standard taker to standard maker. In fact, a similar technology catch-up strategy deployed in other industries (car, rail, air, etc) can be witnessed in the field of AI. One could nonetheless argue that thanks to access to talent, state-sponsored funding, droves of data and unseen adoption, some (Chinese) companies are much closer to the technology frontier than in any other sector previously. An increase in quality and a decrease in cost seems the most potent way to further export Chinese AI-related technologies.

This leaves us with a trypic. One can find both an exponential growth of standards limited to the domestic market, sectors in which China still rests on international standards and a number of sectors in which Chinese companies are starting to be in a position to impose or, at the very least, lead standardization.

### 3. FROM MATERIAL TO IMMATERIAL

As economies develop, they tend to abandon the manufacturing of goods to concentrate on more profitable sectors with a higher intensity of services. The telecommunication sector provides a good example of how some Chinese companies have, over a rather short period of time, moved from exporting first goods, then infrastructure and finally services. For instance, Huawei began at the end of the 1980s as a manufacturer of telecommunication switches. It moved later to building network infrastructure, providing enterprise services and lately to selling mobile phones. To strengthen its competitive edge, the company has invested heavily in R&D, both at home and abroad, often locating its research centers in the vicinity of telecommunication clusters (e.g., Sweden, Germany). In fact, the Shenzhen-based company has occupied the first or second rank of companies with the highest number of patent applications worldwide, accounting in part for the recent rise of China in global patent applications.

Since telecommunications is a standard-intensive industry and two of the global players are headquartered in Shenzhen (the other being Zhongxing Telecommunications Equipment or ZTE), it is not surprising that the city's share in China is so high.<sup>8</sup> As to the usual question regarding the quality of patents, the PCT<sup>9</sup> patenting activity of both companies over the last five years provides an interesting indication. The continuous increase (+500% in ten years) is testimony to the global ambition of some Chinese companies and to their intellectual property (IP) strategies. It nonetheless remains interesting to see that the ratio of domestic to international patent applications in China has remained relatively stable over the years. Moreover, whereas domestic applicants represented only 50% of granted patents in 2009, this figure is close to 80% in 2017. A final figure can help shed light on patenting activity: the ratio of domestically granted patents (over applications) hovers around 25% for residents and 66% for non-residents, indicating that a gap remains between both groups when it comes to quality.

<sup>8</sup> Other companies like BYD in the fast-growing electric vehicle industry further account for the city's heavy investment in R&D.

<sup>9</sup> The Patent Cooperation Treaty (PCT) can be seen as a one-stop "shop" for patenting worldwide.

HUAWEI P30 PRO  
\$363.83  
(COST OF 1,631 PARTS)

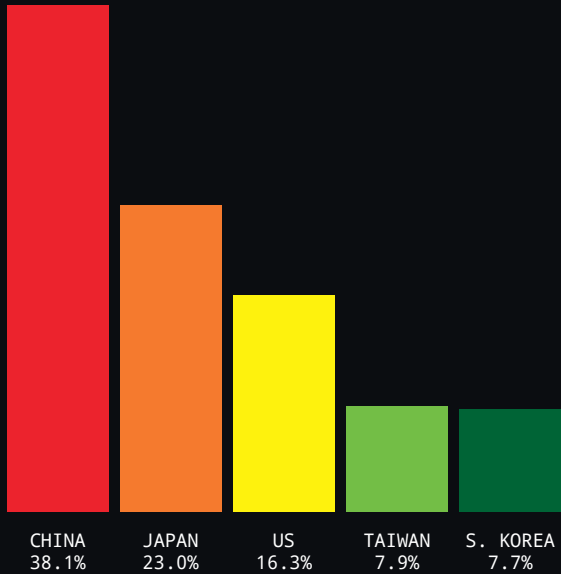
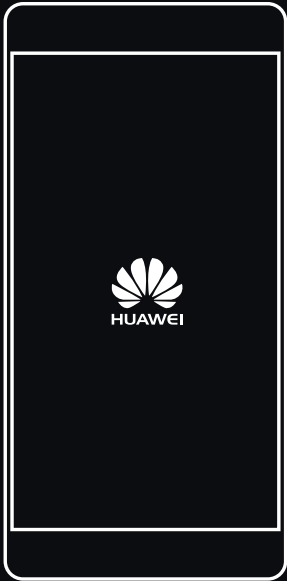

APPLE IPHONE XS MAX  
\$438.2  
(COST OF 1,756 PARTS)

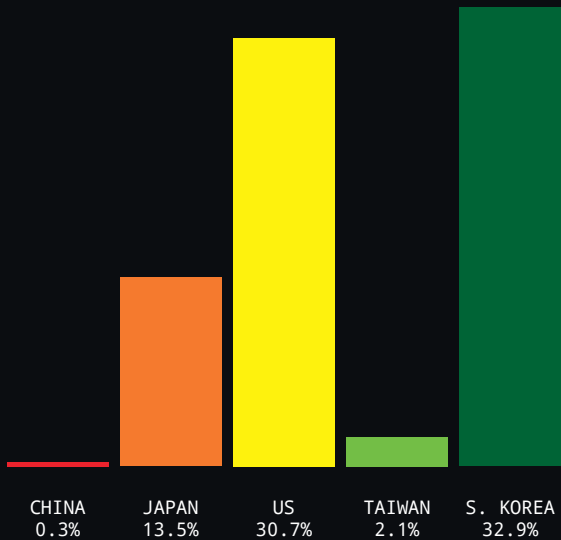

WHERE HUAWEI AND APPLE GET THEIR SMARTPHONE PARTS.  
Dependency on region/territory (percent of total cost). Chinese companies are increasingly able to source their components from domestic providers.

Patents aside, the path to technological leadership is full of pitfalls, including for well-established Chinese companies. ZTE's seven-year component ban from US suppliers in 2018 has shown that different exogenous factors can seriously indent the growth (and even endanger the existence) of a company.<sup>10</sup> Developing "homegrown" technologies and capturing markets abroad still goes hand in hand with ensuring access to chips supplied by US and European companies.

The blacklisting of Huawei by the US in 2019 on grounds of national security has similarly led the company to close some of its research centers in the United States and, according to certain estimates, cost up to USD 10 billion in lost revenues. Both examples point to the importance of integration in GVCs at the research and business level and to the fact that this integration can be derailed rather easily.<sup>11</sup>

The emergence of ambitious, powerful and sophisticated technological companies like Huawei can sow the seeds for an economic war. The 5G saga offers a good case in point. The next generation telecommunication standard is particularly significant as it brings to the forefront the progress achieved by Chinese companies in technology over the last decade. It probably marks a (symbolic) turning point since it is, by-and-large, the first time in recent history that a standard with global reach will come out of China. Its significance goes beyond the immediate economic advantages that standards procure for their owners. It marks the entry of Chinese companies in the business of the immaterial economy. One that scales infinitely. Invisible but central to the functioning of infrastructures is the laying down of tracks for technological trajectories. And of course, the opening of crucial questions relative to the security of critical infrastructures as well as further questions related to issues of privacy and commercial dominance.

#### FROM "MADE IN CHINA" TO "CHINA INSIDE"?

The roadblocks thrown onto the deployment of 5G give an indication of the seriousness with which Western governments and companies treat Huawei's new position in the telecommunication industry. One can wonder whether the most unsettling aspect for Western policy-makers and governments alike is the slow disappearance of easily identifiable goods labeled "Made in China" and their associated trade deficit, replaced instead by a service deficit. At times, one needs to be reminded that, whereas Western economies are net importers of Chinese goods, they are net exporters of services to China. In other words, while importing low to medium added-value goods from China, Western economies have been exporting high added-value (and environmentally friendly) services to China,<sup>12</sup> benefiting from cheap labor, "business-friendly" labor protection and,

<sup>10</sup> Both Huawei and ZTE have been accused by the US Government of breaching the embargo on Iran.  
<sup>11</sup> Thucydides' trap, so often called upon to highlight the dangers of China's rise, could also be applied to the business world.

<sup>12</sup> According to USTR, in 2018 the United States had a service trade surplus of USD 41 billion with China (and a goods trade deficit of USD 419 billion). Sales of services in China by US firms was USD 55 billion in 2016 and USD 8 billion for Chinese firms in the United States.

2005  
100% = 4.7 TERABITS PER SECOND (TBPS)

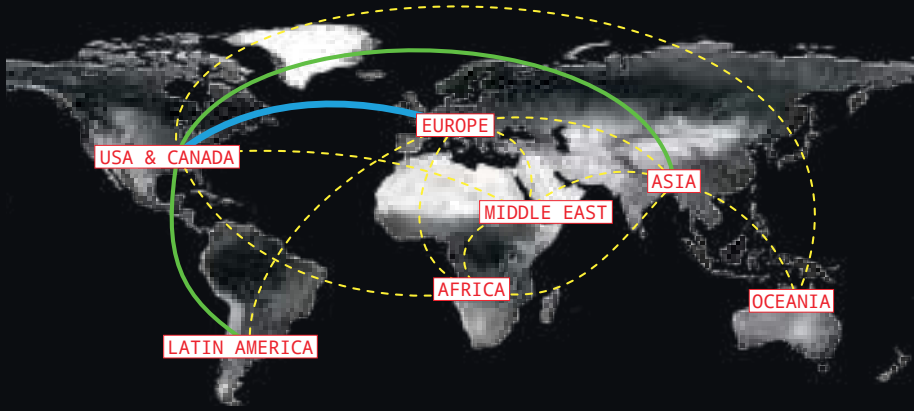

2014  
100% = 211.3 TERABITS PER SECOND (TBPS)  
45X LARGER

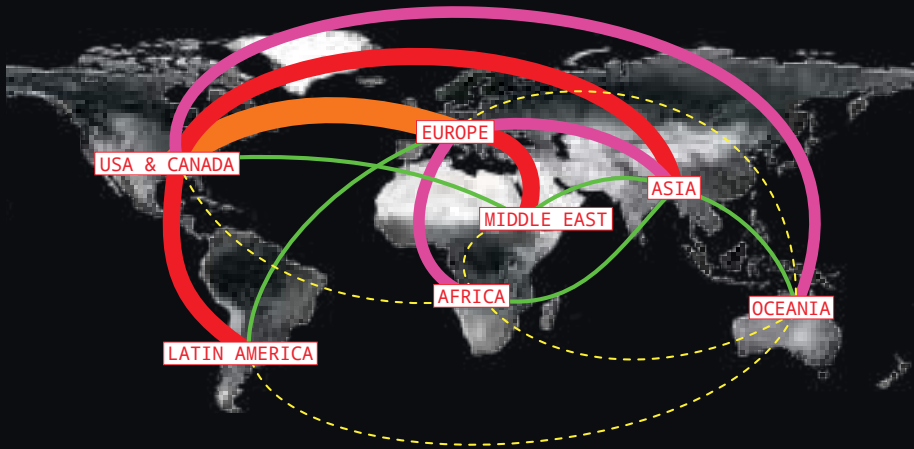

LAYING DOWN THE CIRCUITS.  
Cross-border data flow bandwidth, gigabits per second.

in the end, cheap products in stores. It seems politically much easier to point to millions of containers of goods crossing the ocean on vessels rather than bits and bytes and know-how embedded in hardware going the other way.

For all the political pandering and economic sanctions surrounding the 5G saga, the fact remains that the most advanced Chinese companies are now entering new and immature industries. The economic and technological catching up achieved by Chinese firms was precisely that: catching up. Learning from, imitating, copying from, innovating on top of, was possible because the gap was large and all sides seemed to be winning in the short-term. Now that some Chinese firms are getting closer to the technological frontier, reverse engineering is no longer an option for them. This implies that hitherto successful companies will need to make investments in unproven technologies with much higher risks of hitting dead-ends.

#### A DIGITAL SILK ROAD

While EU and US policy-makers try to protect their markets (at great cost to their consumers), Chinese companies have been steaming ahead with the deployment of homegrown technologies in emerging markets. Huawei is said to have installed 70% of African 4G networks (Bayes 2019). Thanks to the Belt and Road Initiative (BRI) launched in 2013 by Xi Jinping, Chinese companies can count on one of the most ambitious infrastructure development plans of the 21st century to export their know-how.

A seemingly infinite list of services can be deployed along BRI. Indeed, its infrastructure is not limited to rails, docks and electricity pylons—e-commerce and smart cities (for example, Kuala Lumpur's City Brain), undersea cables<sup>13</sup> (linking Asia and Africa), data centers, customs automation (Digital Free Trade Zone in Malaysia), Silk Road e-Merchants, even the Digital Belt and Road Program (DBAR) for sustainable development, initiated in 2016 by Chinese scientists to improve environmental monitoring, promote data sharing and support policymaking using big data on Earth observations. BRI could become the most formidable vehicle for the exporting of goods and services, and for importing data related to the activities enumerated above.

BRI and domestic markets aside, if China was to play an even more important role (e.g., weighing in on global data or AI standards) it would need to become a net importer of data from the West, something that the United States excels at with the GAFAs.<sup>14</sup> In what appears to be a preemptive strike, the Trump administration has already warned consumers and governments about the risks of DJI drones sending information to servers in China (a rather ironic posture since the rest of the world sends large chunks of their data to servers in the United States).

<sup>13</sup> Historical parallel with Britain cutting Germany from its telegraph cables during World War I but also cables as a conduit for the spread of ideas.

<sup>14</sup> One can wonder what role European companies intend to play.



FREIGHT TRANSPORT OF CHINESE ELECTRONICS (HUAQIANGBEI, SHENZHEN).

Data flows have notably expanded over the past decade and this growth continues at a brisk pace. International organizations have already started to measure the world economy through data flows (Caslini and Lopez 2019). It may not be long before countries complain about a data balance deficit.

In other words, and if techno-nationalism does not prevail, the Chinese government's Belt and Road Initiative (BRI) could serve as a formidable springboard for placing Chinese blocks of standardization in upcoming growth industries and markets. Visiting the showrooms of the leading Chinese social media companies, one can easily envisage how exporting an ecosystem integrating infrastructure, services and the organization of society could be next. Such export-driven development strategies nonetheless remain dependent on the openness of other economies. The current trade war between the United States and China serves as a powerful reminder of how quickly and strongly trade relations can deteriorate, and to a certain extent, of how dependent the Chinese companies are on foreign technologies.

#### 4. CONCLUSION: BLOCKS AND ROADBLOCKS...

Over the past three decades, the Chinese economy has played very different roles in the global economy. It started by exporting (cheap) labor at a high social and environmental cost. Through BRI, it is currently exporting its surplus infrastructure building capacity. Thanks to notable advances in some technological fields (e.g., mobile telephony and facial recognition) it already exports know-how and intellectual property at very low marginal cost. By outsourcing low-end textile manufacturing to South-East Asia and East Africa, China is already importing (cheaper) labor, hence coming full circle.

Before closing this chapter, one can wonder what role Shenzhen plays in producing standards and standardization? For now, the role of the city in terms of standards is mainly linked to the telecommunication industry. There is no reason to expect the city will develop another industrial cluster with the same scale as telecommunications any time soon. Political support in the form of policies incentivizing innovation up to fully-fledged industrial policies can go a long way towards creating national champions. It is not always easy to sustain exports without strength "at home." At the same time, a strong presence at the domestic level does not guarantee success abroad. Going the extra mile may require a different ingredient, namely soft power. So far, the Chinese government and companies have seemed to fall short of this resource. Soft power can come in handy when money or superior technology does not suffice to win over international organizations, governments and companies.

Positioning Shenzhen as the Silicon Valley for hardware further indicates the role the city intends to play. Whether the city can ever assume the same real and imaginary function is another question. In the past, Silicon Valley has managed to integrate the flow of money, technology and talent like few others. To rival the success of Silicon Valley, the Shenzhen Valley will need to emulate its attractiveness.



FREIGHT TRANSPORT OF CHINESE ELECTRONICS (TRANSIT).

At the same time, Shenzhen is part of the ambitious Greater Bay Area (GBA) initiative.<sup>15</sup> One can imagine it playing (once again) the role of a pilot in this massive con-urbanization project. In fact, the GBA is at the forefront of an in-depth transformation of the Chinese economic development model. To strive or simply to survive, companies have launched into massive automation projects, shedding in passing thousands of jobs. Paradoxically, automation makes China a less interesting place for production, unless Chinese factories can find ways to achieve similar productivity gains as factories in the West in addition to the proximity of a large market. Year after year, during the visit to a medium-sized PCB factory on the outskirts of Shenzhen, one could notice how machines have (already) replaced operators at certain stages of the production process.

Cities like Shenzhen and companies like Huawei and Tencent already act as key blocks in the circulation of goods and services domestically. If the ambition of the Chinese government and economic actors does not fall short, the next iteration will be to play a similar role beyond the Chinese borders and further than emerging markets. But while technology plays a central role in the relationship between China and the world, China remains by-and-large dependent on foreign technology flows to innovate and increase productivity.

#### REFERENCES

- Bayes, T. 2019. “African Networks, Smartphones—and Surveillance.” Retrieved June 18, 2019, from [meric.org](http://meric.org) website.
- Breznitz, Dan, and Murphree, Michael. 2013. *The Rise of China in Technology Standards: New Norms in Old Institutions*. Washington, DC: US-China Economic and Security Review Commission.
- Casalini, F. and J. López González. 2019. “Trade and Cross-Border Data Flows,” *OECD Trade Policy Papers*, No. 220, OECD Publishing, Paris.
- Dedrick, Jason, et al. 2010. “Who Profits from Innovation in Global Value Chains?: Study of the iPod and Notebook PCs.” *Industrial and Corporate Change*, 19 (1), 81–116.
- Inomata, S. and Taglioni. 2019. “Technological Progress, Diffusion, and Opportunities for Developing Countries: Lessons from China. *Global Value Chain Development Report 2019*. Geneva: World Trade Organization.
- Kaplinsky, Raphael. 2010. *The Role of Standards in Global Value Chains*. Washington, DC: World Bank.
- Levinson, Marc. 2006. *The Box: How the Shipping Container Made the World Smaller and the World Economy Bigger*. Princeton, NJ: Princeton University Press.
- Maddison, Angus, n.d. Organisation for Economic Co-operation and Development. Development Centre. 2007. *Chinese Economic Performance in the Long Run*. Second edition. Paris: OECD.

<sup>15</sup> GBA refers to the Chinese government’s project to link the cities of Hong Kong, Macau, Guangzhou, Shenzhen, Zhuhai, Foshan, Zhongshan, Dongguan, Huizhou, Jiangmen and Zhaoqing into an integrated economic and business hub.



中國郵政  
CHINA POST

FR



LD 257 090 499 124

1. 本封套內裝有  
2. 本封套內裝有  
3. 本封套內裝有  
4. 本封套內裝有

Sender's Name  
[Redacted]  
Address  
[Redacted]  
City  
[Redacted]  
Country  
[Redacted]

No.	Description of Goods	Qty	Unit Price	Goods Charge
1	[Redacted]	[Redacted]	[Redacted]	[Redacted]
Total Goods		0.500	0.00	

Sender's Signature & Date

CNS

FREIGHT TRANSPORT OF CHINESE ELECTRONICS (ARRIVAL IN EUROPE).

- Manyika, James, et al. 2016. *Digital Globalization: The new era of global flows*. McKinsey Global Institute.
- Nadvi, Khalid. 2008. "Global Standards, Global Governance and the Organization of Global Value Chains." *Journal of Economic Geography*, 8 (3), 323–343.
- Shen, H. 2018. "Building a Digital Silk Road? Situating the Internet in China's Belt and Road Initiative." *International Journal of Communications Law and Policy* (12), 2683–2701.
- Woetzel, Jonathan, et al. 2019. *China and the World: Inside the Dynamics of a Changing Relationship*. McKinsey Global Institute.
- World Bank. 2017. *Global Value Chain Development Report 2017: Measuring and Analyzing the Impact of GVCs on Economic Development*. Washington, DC: World Bank.







***MOIOROIA***



**SONTIA**

# AN ARCHEOLOGY OF SHANZHAI PHONES

山寨手机考古报告 | Clément Renaud & DISNOVATION.ORG

The “Made in China” label has become famous for the short-lived existence of its products. Usually despised as an industrial subgenre, it has nevertheless vastly contributed to furnishing and structuring the daily existence of millions. While entire museums have been dedicated to niche practices in arts & crafts or to the prowess of famous designers, one can ask: what will remain of these “Made in China” products in the future? For now the archiving of fast-disappearing artefacts may seem a questionable endeavor compared to the emergency of recycling them. Still, even if these objects fall outside the category of significant inventions or indigenous artifacts, for large chunks of the human population they represent an integral part of their living memories and therefore may be considered for conservation.

*Shanzhai* (山寨) is a derogatory term used in China to qualify objects that are cheaply made, poorly counterfeit or just plain crappy. In a way, *shanzhai* evokes to a Chinese person a similar concept to “Made in China” for a Western one. Originally referring to a “mountainous village,”<sup>1</sup> its association with Shenzhen—the name of the city where the whole “Made in China” industrial relocation began—has certainly helped spread the word. Formerly known for its loose tax regulations and copyright enforcement, the Shenzhen Special Economic Zone (SEZ) was—and somehow still is—China’s original sweatshop. The mountains located on the outskirts of the SEZ have over the years sheltered an incredible amount of small plants specializing primarily in making and assembling toys, clothes and electronics. Over time, they learned to disassemble, recreate and sell these products and devices—often adding some personal touches to branding and design in the process. From this adaptive process hatched a large number of manufacturers specializing in very cheap and inadequate products, that became known across China as the *shanzhai factories*.

Since 2010, the city of Shenzhen has been raising its international profile, propelling its gigantic IT industry to the forefront of the global stage with the presence of industry leaders like Huawei, Tencent or DJI. The *shanzhai* story started to gain momentum in design and academic circles outside China, turning

1 The term was originally popularized in the Chinese classic stories *Outlaws of the Marsh* (水浒传) and is therefore associated with the epic feats of China’s outlaws.



FOR ARCHAEOLOGISTS, FRAGMENTS OF A BIFACE HELP EVOKE PAST REALITIES BY PROVIDING INFORMATION ABOUT THE GESTURES THAT CREATED SUCH AN OBJECT.

the factories into glorious renegades (Keane & Zhao 2012), precursors of iterative product design (Wu and Taniguchi 2012) and manufacturing (Lindtner et al. 2015). As of today, hundreds of publications have discussed this unique phenomenon from design, industrial, entrepreneurial, critical and even fashion perspectives. For the city of Shenzhen, stories of the *shanzhai* factories are kept alive as part of a foundational mythology, even though most plants were forced to close down many years ago by rising land costs or reform campaigns. Many of the original factories were undeclared or just plain illegal. Most factory owners were migrants from other parts of China who relied extensively on informal networks from their villages of origin. Rising costs and competition with larger firms made the release of products harder, leading to less frequent seasonal assembly and a gradual departure of factory workers. As of today, very few original accounts of life in these factories exist. Despite the fashionable tone now represented by the term *shanzhai*, working conditions in these plants were harsh, often making a job at Foxconn a desirable achievement.

While all this history is gradually being replaced by the story of Shenzhen's global technological hub, the *Shanzhai Archeology* project aims to collect and archive the disappearing artifacts produced by these *shanzhai* factories. It is an effort of conservation of outstanding specimens, together with their uses, functions, stories, and areas of circulation, as a way to narrate a larger geopolitical and historical transformation concerning the global lives of manufactured technologies over the past 40 years. Within the myriad of objects available on the market, we chose to focus exclusively on mobile phones, as it is one of the most iconic technologies that has survived through two decades of rapid change and technological trends. To date, we have bought and collected around a hundred phones from diverse sources. The collection has been exhibited numerous times in Europe, where most models were unknown because of border regulations forbidding their circulation. This chapter narrates the whys and hows of the *Shanzhai Archeology* project, from our original intent of collecting to its actual unfolding and reception. We will discuss how our 21st century orientalist cabinet came into existence, and the questions it raised among a European audience.

#### SHANZHAI AND THE WESTERN IMAGINARIES OF TECHNOLOGY

The most interesting thing about a phone shaped like a strawberry or one with its own gas lighter is that, by simply existing, it screams how standardized and boring the Western imaginaries of technology have become.

For archaeologists, fragments of a biface help evoke past realities by providing information about the gestures that created such an object. The shape of a biface evolved from a human hand that dictated a *de facto* form factor (Ingold, 2013). Despite this *de facto* standardization force, its original functions (to cut, to drill, to flatten, etc) have since dispersed, evolving into multitudes of shapes and colors. For the phone, the convergence of all designs towards a black-square-with-rounded-corners can be attributed as much to the shape of the hand and eye than to the organization of production lines and shipping of cardboard boxes.

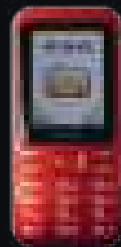
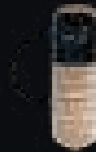
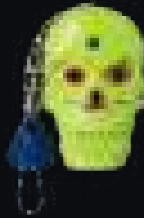
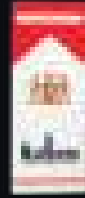

SHANZHAI PHONES: CARD PHONE, BUDDHA PHONE, POWER BANK PHONE, CIGARETTE PACK PHONE, WOODEN PHONE, STRAWBERRY PHONE, LIGHTER ZIPPO PHONE, PRISONER PHONE, TOY PHONE, RAZOR PHONE, CAR PHONE, SOUND SYSTEM PHONE.

More than an exploration of the product itself, an archeology of *shanzhai* is an exploration of the design intentions, the conditions of production, the markets and usages. Sometimes compared to an industrial “Galapagos” (Huang 2013), the *shanzhai* industrial ecosystem involved a set of actors that are mostly absent in the usual “tech miracle” narrative of Californian chivalry. The first actors we need to mention here are the workers of the electronic assembly lines who outnumbered in every conceivable manner all other operators in the vast landscape of digital technology. They came by the tens of millions from all corners of rural China to make the Internet possible. The second actor would be the Chinese Communist Party who, by deciding to invest heavily in the IT sector and allow direct, tax-free foreign investment in the SEZs, created the possibility of affordable home computers and mobile phones worldwide. The third and final set of actors encompasses all the owners of the small Chinese factories that took virtually any product idea presented to them and made them a reality—even though these ideas were not always fully functional or durable.

To follow the archeology of *shanzhai* is to reconstruct new technological trajectories that have been largely ignored. Interestingly, the need for Western companies to maintain profit growth and returns on investment acted as a major incentive to standardize components and supply chains for electronics. The major reason why Intel decided to release the standardized ATX form-factor for motherboards was due to the CPU market value decreasing so fast (up to 1.5% per week) that the shipping delay to the US became too costly and needed to be reduced (Chien and Wang 2010). ATX standardization led to a proliferation of small factories that began to follow Intel and other constructors guidelines to produce the required components. Factories began to sell these computers directly to customers and resellers abroad, leading to a surge of no-brand “white box” PCs that people began to install at home in the late 90s. At the same time, the Taiwanese electronic manufacturer Mediatek, inspired by the experience of white box manufacturers, decided to conquer the cell phone market by selling cheap, barebones kit phones directly to smaller factories (Chang 2010). Shipped with a fully functional PCB chipset and complete documentation, the company’s strategy succeeded in capturing the market of manufacturers who started to produce all kind of phones based on these kits.

In many regards, what has been called *shanzhaiji* (*shanzhai phones*), emerged with the inception of MTK kits. The core features provided by these kits allowed manufacturers to focus on all sorts of integrations, often driven by speculative visions of a possible market, by the mash-up of existing phones and trending tech gadgets, or by existing industrial connections. For example, a remote cousin making plastic molding for toys would be an ideal business partner to make plastic dolphin cases for a batch of phones. Compared to the sophistication of global supply chains involved in the making of an iPhone, the simplicity and velocity of *shanzhai* manufacturing stands out through its practice of trial-and-error, with small incremental iterations of products, possibly leading in some cases to innovations with long-lasting consequences. Often visually

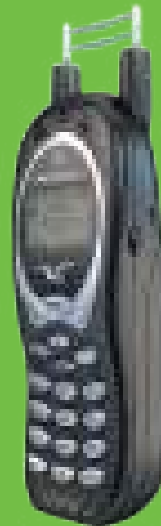
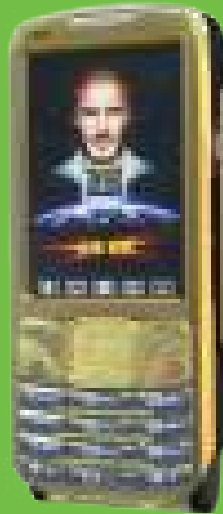

SHANZHAI PHONES, 3D RENDERING: CIGARETTE PACK PHONE, RAZOR PHONE, PEN PHONE AND TASER PHONE. 3D rendering: Terrell Davis.

indistinguishable between iterations, these feature phones are made in relatively small quantities and circulated directly through resellers across China and worldwide, as well as through online shops.

Functions of these phones vary as well, sometimes in an anecdotal manner, sometimes with entirely new features, sometimes in a purely decorative sense. A phone shaped as Mickey Mouse or a fluorescent skull first strikes one as a completely useless gadget, right before we remember that the aesthetics of productivity associated with today's mobiles may one day be regarded as some strange 21st-century custom.

#### DISAPPEARING ARTIFACTS

Further to the origin and making of these phones, we need to consider their entire lifecycle. Struck by extreme obsolescence, the duration of their existence as phones is determined by different factors: the success of their sales, the will of the buyer to keep them, or their own failure as functional devices. The high risks associated with all these criteria makes the *shanzhai* business a very wasteful one. The very low level of entry in the market encourages cut-throat competition for the lowest costs and the most aggressive deadlines, leading to all kinds of defects and quality control issues—including entire stocks being totally dysfunctional or never entering the market. For this reason, models that are not profitable from day one, or that stop being produced for some reason, are virtually impossible to find after a few weeks. To save on costs, an entire industry of recycling exists to buy back these phones and convert them into parts. The opposite is also true, with used parts often finding their way into these phones in order to lower the cost of materials, making them even more prone to breakage.

For all these reasons, *shanzhai* phones can be hard to find—and to conserve. The models you may have seen online are not always available, or arrive with slightly different aspects or specifications: the plastic wears out quickly, the battery leaks easily, etc. Conversationally, these phones are also hard to obtain within the EU or the US, as regulations usually prevent them crossing customs borders. In this respect, an important part of the *Shanzhai Archeology* project was to source the phones from mall kiosks and street vendors in Shenzhen and other cities in China, as well as from various websites. Apart from the always useful Chinese e-commerce platforms like Alibaba and Aliexpress, we began to frequent different e-commerce websites from unexpected countries, where the phones were to be found. Less interesting were the hours spent talking to a diverse range of officers and clerks in European airports and customs administrations. Per EU regulations, most of these phones were not allowed because of the absence of proper CE marking.<sup>2</sup> The Li/Li-On batteries especially were qualified as hazardous and were ultimately forbidden from being transported on any aircraft as per IATA rules.<sup>3</sup> From manufacturing, to online sales and border

2 CE marking is a certification mark that indicates conformity with health, safety and environmental protection standards for products sold within the European Economic Area (EEA).

3 IATA official website, consulted on January 15, 2018.



TOP: HUAQIANGBEI ELECTRONICS MARKET, SHENZHEN, CHINA.

BOTTOM: SHANZHAI ARCHEOLOGY INSTALLATION, MAISON POPULAIRE, MONTREUIL, FRANCE.

regulations, an interesting geography began to appear around the (absence of) circulation of a large part of our *shanzhai* phones, where Europeans were safely kept out.

When we began the project, most *shanzhai* factories had transitioned out of the *shanzhai* model, or had already closed. Thankfully from 2014, the *shanzhai* phone had become a well-established online meme, and we were able to find traces of those models of phones that had disappeared years ago. While it was sometimes hard to differentiate parodies and jokes from actual existing models, we began to establish a wishlist of phones in the form of Wild West–esque wanted posters. We were able to get our hands on some of the most recent or common specimens that were still in stock or in production, but for the most part we knew the search was a lost cause. Based on the pictures and materials we were able to collect, we decided to recreate a selection of older specimens as 3D models. This led us to also model in 3D some of the pieces we had bought, as we knew they might quickly degrade or disappear. The practice of digital conservation has been a force for creative renewal in the world of archeology<sup>4</sup> and it made sense here as no culture of conservation of these objects currently exists. In an effort to digitally conserve a worldwide phenomenon, we also consolidated our findings into an archive that contains visual documentation sourced online, featuring fan art of various fictional, fantasy, unbridled and improbably multifunctional phone models that were directly inspired after Internet user exposure to a highly mediatized *shanzhai* culture.

#### COUNTERFEITING THE ORIENTALIST CABINET

A problematic aspect of explaining *shanzhai*—or most things Chinese—to someone who has never visited China is the impossibility of communicating the experience of actually being there, for instance the busy, intense and sensorially overwhelming environment of Chinese hi-tech malls. As our practice of collecting needs to be contextualized, showcased and circulated, we recreated a kiosk as they can be found in electronics markets in China, including large flashy LED panels and a glass display enclosing the phones. Besides the kiosk and the phones we also started a larger documentation process, visiting Shenzhen several times, conducting interviews with locals and academics, filming the practices of design, production, sale and use, and, of course, reading avidly the existing literature. We originally conceived of the kiosk in St Etienne (France) with the intent that its unusual silhouette would serve as a disruption within the codified networks of the Design Biennale. Spectators complained about the lack of context around the display, and the difficulty for them to relate to the full meaning of the piece. Of course, the aesthetic value of the phones was acclaimed by questions such as: “How did you make them?” and, most commonly “How much for this one? I want to buy it for my son!” In the exhibitions that followed, more context was added to the display, with images, video documentaries, texts from knowledgeable authors and academics, and more.

4 See, for instance, New Palmyra. <https://newpalmyra.org>



# LETRE

DU

**PERE D'ENTRECOLLES,**  
Missionnaire de la Compagnie  
de JESUS:

*De son Ouy de la même Compagnie.  
Provincia des Missions de la Chine  
de son Indes.*

*A son oncle, le 7  
septembre 1712.*



**ON REVEREND PERE,**

*Le Père de N. S.*

Le séjour que je fais de vous  
en venant à Kiang se prolonge pour les

214 *Letres de quelques*

beloim spirituels de mes Néophytes, m'a donné lieu de m'instruire de la manière dont s'y fait cette belle porcelaine qui est si estimée, & qu'on transporte dans toutes les parties du monde. Bien que ma curiosité ne m'eût jamais porté à une semblable recherche, j'ai cru cependant, qu'une description un peu détaillée de tout ce qui concerne ces sortes d'ouvrages, étoit de quelque utilité en Europe.

Outre ce que j'en ai vu par moi-même, j'ai appris beaucoup de particularités des Chinois, parmi lesquels il y en a plusieurs qui travaillent en porcelaine, & d'autres qui en font un grand commerce. Je me suis encore assuré de la vérité des réponses qu'ils ont faites à mes questions, par la lecture des livres Chinois qui traitent de ces

*Alphabétiques de la C. de J. 215*  
te matière: & par ce moyen-là j'étois arrivé à acquiescer une connaissance assez exacte de toutes les parties de ce bel art, pour en parler avec quelque confiance.

Parmi ces livres, j'ai vu entre les autres l'Histoire ou les Annales de *Fou-tsun*, & j'ai lu avec soin dans le quatrième Tome l'article qui regarde la porcelaine. *King-te-king* qui dépend de *Fou-tsun*, m'en est décrit que d'une bonne lieue; & *Jou-koan* est une ville de la dépendance de ses côtes. C'est un usage à la Chine, que chaque ville marque l'Histoire de son district: cette histoire comprend la situation, l'étendue, les limites, & la nature du pays, avec les endroits les plus remarquables, les mœurs de ses habitans, les personnes qui s'y sont distinguées par les armes & par les lettres,



TOP: Section of a letter from Francois Xavier d'Entrecolles concerning Chinese porcelain manufacturing techniques, 1712, re-published by Jean-Baptiste Du Halde in 1735.

BOTTOM: This rare dish, made in Jingdezhen for the western market, exhibits an interesting blend between a classical 18th-century European style and typical Chinese patterns, landscapes and even characterizations.

Still, the act of bringing and displaying Chinese artifacts to Europe bears a striking resemblance with the orientalist cabinet of the 19th century. This parallel is amusing in several different respects. The discourse around counterfeiting has been present in the background of most discussions about the Chinese electronic industry, with *shanzhai* located right at its lower end. During our research, we discovered the interesting story of the Jesuit priest François Xavier d'Entrecolles (殷弘緒 Yin Hongxu) who was born in Lyon in 1664 and died in Beijing in 1741. Father d'Entrecolles arrived in China as a missionary in 1698, where he was praised for his deep knowledge of the Chinese language and sent to Jingdezhen—the capital of the famous art of Chinese porcelain—to appreciate the highest levels of refinery in the Empire. In a letter dated September 1712, the missionary related to his French correspondents that he had finally managed to witness firsthand how the precious pottery was cast, revealing in detail his host's secrets that would, a few decades later, give birth to the European porcelain industry. It is somehow ironic that Victorian England and Napoleonic France's most refined goods originated from such a blatant case of industrial espionage—and counterfeiting on a continental scale. By counterfeiting a Chinese kiosk of counterfeiters, we keep alive this long lineage of piracy and the looting of Chinese knowledge to the benefit of arty European salons. We hope that showing these phones outside China can carry us away from our dominant, one-sided stories about innovation and eventually help us escape our normative imaginaries of technology.

#### REFERENCES

- Chang, Shih Chi. 2010. "Bandit Cellphones: A Blue Ocean Strategy." *Technology in Society* 32 (3): 219–23.
- Chien, Chen-Fu, and Jyun-Cheng Wang. 2010. "Shanzhai! Mediatek and the 'White Box' Handset Market." *Harvard Business Review*, December.
- Huang, Bunnie. 2013. "The \$12 Gongkai Phone." *Bunnie Studios* (blog). April 18, 2013.
- Ingold, Tim. 2013. *Making: Anthropology, Archaeology, Art and Architecture*. London: Routledge.
- Keane, Michael, and Elaine Jing Zhao. 2012. "Renegades on the Frontier of Innovation: The Shanzhai Grassroots Communities of Shenzhen in China's Creative Economy." *Geography* 53 (2): 216–30.
- Lindtner, Silvia, Anna Greenspan, and David Li. 2015. "Designed in Shenzhen: Shanzhai Manufacturing and Maker Entrepreneurs." *Aarhus Series on Human Centered Computing* 1 (1): 85–96.
- Wu, Eddie, and Makiko Taniguchi. 2012. "Shanzhai: Copycat Design as an Open Platform for Innovation." Patterns from IDEO. Designing Insights Emerging and Converging. IDEO.



# POWER BANK PHONE

---

Brand:	X-Tigi
Model:	S18
Release date:	2014
Size:	177*104*57 mm
Battery capacity:	10000 mAh
SIM cards:	3
RAM:	<128M
Display resolution:	320x240 (QVGA)
Special function:	Power bank, sold with USB LED light
Price:	US \$25-38

---

Produced by the Chinese firm X-Tigi, the *Power Bank Phone* is sold primarily in Accra, Ghana. With features such as a three-card SIM reader and a USB port to connect another phone on the back, this device may appear bizarre to those used solely to Californian or Korean designs. To understand the nature of this design, we need to make the jump to the streets of Accra where the phone is used.

The capital city of Ghana has grown tremendously since the 2000s, becoming one of the most important technological hubs in West Africa. Still, power outages throughout the country are so frequent that they have their own word: *dumsor*—meaning *on and off* in the Akan language. Charging a phone can quickly become a problem, and a massive battery capacity as well as the ability to charge another device can be very useful. In addition, this phone is often sold with a USB bulb which can illuminate any room, thanks to the hook integrated into the phone.

In many places on the African continent, mobile operators will charge more if the number called is operated by a different company. To keep bills reasonable while still calling who they like, people have been using multiple SIM cards and numbers to call each other. Instead of constantly switching cards or owning several phones, having a phone with 3 SIM slots is a very handy solution.

There are several more options on the *Power Bank Phone* that directly answer issues faced by local phone users, such as a high-powered antenna and reinforced case for better use in rural and remote areas. Chinese entrepreneurs have been coming to Africa in the guise of businesses, individuals and families for decades now. Relying on Southern China's manufacturing powerhouse, they have pulled together devices to address daily issues they have witnessed locally. Oftentimes, their own background in China's rural areas has helped them to identify needs and even to test them in China, matching this with an industrial knowledge of export and fabrication. As of today, Chinese mobile phone companies—such as *Transsion*—are leaders on the African continent, far from the Western image of “tech” that suddenly appears isolated in a much larger world.



# CARD PHONE

---

Brand:	Card Tec
Model:	CM1
Release date:	2012
Size:	85*54.5*6.3 mm
Battery capacity:	320 mAh
SIM cards:	1
RAM:	8M
Display resolution:	320x240
Special function:	--
Price:	US \$12-29

---

No bigger than a credit card, the *Card Phone* costs less than 12 US dollars and is composed of a single board. A stand-out due to its very simple architecture, it is nevertheless a complete phone with quad-band GSM, Bluetooth, MP3 playback, an OLED display and a backlit keypad. This model is composed of a MT6250 board from the Taiwanese company MediaTek (MTK), and a few accessories (plastic case, mic, charger cord, etc.).<sup>1</sup>

The *Card Phone* exemplifies two complementary dynamics: the strategy of Taiwanese chipset constructors to capture the mobile phone market, and the tactics of product development by Chinese manufacturers. Inspired by the success of no-brand computers in the 1990–2000s (called *white boxes*), Taiwanese companies such as MTK began producing multipurpose chips with support for GSM and other standards (Bluetooth, etc.) with the goal of bypassing the usual brands in order to work directly with factories. By flooding the market with cheap boards—such as the MT6250 used in the *Card Phone*, they established a network of resellers in Southern China that could push products directly to design houses that focused on developing new forms and features for the phone market.

This ready-made piece of technology allowed factories to transform into design houses. They soon started designing their own phones based on the cheap and available MTK chipsets, effectively giving birth to *shanzhai* phone manufacturing. They relied on their existing industrial network—often friends and families—and started to accumulate available resources (plastic molding, electronics, clothing, etc.) to bring their latest ideas to life. Contrasting with the strong marketing of the open-source movement, these informal practices were extremely competitive and led to a race towards cost-cutting and aggressive pricing that somehow culminated with the barebones iconic design of the *Card Phone*.

Such phones, with their simplicity and low price range, have been instrumental in democratizing access to mobile phones globally over the past decade.

1 Huang, Bunnie. 2013. “The \$12 Gongkai Phone.” *Bunnie Studios* (blog). April 18, 2013.



# SOUND SYSTEM PHONE

---

Brand:	GoFly
Model:	A8
Release date:	2016
Size:	144*67*30mm
Battery capacity:	8800mAh
Screen size:	3 inches
SIM cards:	2
RAM:	<128M
Display resolution:	320x240
Special function:	Torch
Price:	US \$40-60

---

The *Sound System Phone* stands out with its red case, large buttons and powerful back-facing speakers. The device answers the need of a demographic usually forgotten by mobile phone marketing and other “tech revolutionaries”: the elderly. In China, the growing distance between family members and the increasing reliance on digital technology in daily life (payment, administration, communication, etc.) had made access to mobile phones for the elderly an important endeavor.

Anyone who has strolled around the public parks of Chinese cities will remember the groups of elderly present there, usually busy with dancing, singing or playing mah-jongg. The ability to play music aloud is unquestionably a selling point, as dancing in China is an important practice in public spaces with millions of men and women meeting each evening on squares all across China to practice their dance steps—the famous *guangchang wu* (广场舞). Therefore a tool that can broadcast music outdoors—and can also hold several gigabytes of old-fashioned Chinese songs—is a sure sell to pensioners.

While hundreds of millions of people in China have moved to cities over the past decade, the elderly have often stayed at home in the countryside. Recent generations of urbanites have been struggling to bring their family together in their new city of choice—traditionally in order to look after the kids. This *Sound System Phone*, with its integrated flashlight to better find one’s way home after dancing, seems to have been designed with life in the countryside in mind.

The design and features of the *Sound System Phone* cast light on the propensity of large brands to exclude a growing part of the population from their dominant representations of technology.



# BUDDHA (GOD) PHONE

---

Brand:	MAFAM
Model:	U1 (copy of Wellwishing Zen)
Release date:	2016
Size:	74.6*52*21.8 mm
Battery capacity:	500 mAh
SIM cards:	2
RAM:	<128M
Display resolution:	320x240
Special function:	Digital altar
Price:	US \$36.58-54.34

---

This model is a cheap replica of a luxurious original creation commercialized under the name of *Wellwishing Zen*. Designed as a digital alternative for Buddhist prayer and related religious activities, the original *Buddha Phone* replicates some of the essential ritual components: the burning of incense, purification rites and meditative music.

The original *Wellwishing Zen* phone was designed by the Shenzhen-based company *Artop* as an attempt to create a phone whose inspiration would not be Californian, but typically Chinese. The design research process involved a collection of Buddhist symbols, motifs and patterns found in Xixinchan Temple, at the foot of Mount Gaoding in Hunan Province. With the help of the monks, a set of prayers and lessons were identified and added to the phone, with other built-in features such as the ability to choose an idol with which to make a prayer, light a candle, and offer a fruit or a flower. A Buddhist calendar was included as well as a library of Buddhist texts and quotes, and automatic reminders for Buddha and various Bodhisattva's birthdays. Each phone was then built with precious metals and blessed by one of the disciples of the temple.

After its release, the original model sold at a very expensive price on a luxury niche market. In a matter of months, many copies started to appear in shops online and offline across China. The *Buddha Phone* included in our collection is made of cheap plastic but retains many of the features and contents of the original, with Buddhist materials, calendars, in-app rituals, etc. While the company who originated the product may disapprove of the counterfeiting of their work, the more proselyte monks may have found it very satisfactory.

Beyond its strange shape, the trajectory of the *Buddha Phone* shows how the original-copy dynamic is not driven by West-East opposition, but by far more complex market and cultural forces.



# PRISONER PHONE

---

Brand:	LONG-CZ
Model:	J8
Release date:	2014
Size:	68*23*11 mm
Battery capacity:	320 mAh
SIM cards:	1
RAM:	32 Mo
Display resolution:	480x320
Special function:	99% plastic, voice changer, Bluetooth headset
Price:	US \$27.99

---

The *Prisoner Phone* or J8 model from the Chinese brand Long-CZ, was originally marketed as the world’s smallest mobile phone. Made of 99% plastic, the device turned out to be barely detectable while crossing security checks at airports and prisons.

In Ireland and the United Kingdom, where phones are forbidden during incarceration, such mini-phones quickly gained notoriety across inmate populations. To continue conversing from the inside, prisoners were smuggling the phones “internally.” These tiny devices were such a hit in the UK and Ireland that in 2008, prison directors decided to install counter devices known as Body Orifice Security Scanners—nicknamed the BOSS. Advertized online as the “Beat the Boss phone”, these small devices continue to be widely used, with hundreds of items seized every year. Easy to conceal and transport, they can also be readily smuggled in by drones or even carrier pigeons.

Similar phones were used to arrange a prison escape in 2016 in the UK, after which anti-mobile security measures were drastically increased, including a wide variety of deterrents and detectors.

Despite its small size, the feature set includes a camera and two SIM slots. While the original model did not present any special features beyond its size, later models came with improvements such as a voice changer to modify the voice print of the caller, and later a smartphone version. A number of fantasy cases also started to appear, with miniature mobile phones now disguised as BMW car “fobs”, or a replica of the iconic Nokia 3310.

Originally designed to look like a Bluetooth headset, the *Prisoner Phone* demonstrates how an original intent can be diverted unexpectedly, and how technology is transformed and redefined by the ways it is used.







CROWDS TAKE OVER AIHUA ROAD.  
Devices in various conditions re-entering circulation through the ghost market.

# THE GHOSTS OF SHENZHEN

-----  
 深圳鬼市 | Dennis de Bel  
 -----

In the dead of night, I set out to investigate rumors of something best described as paranormal activity. Around midnight I arrive at the presumed site—the Aihua Residential Quarters. As I wander around, midnight slowly turns into dawn. Not much out of the ordinary is going on. Suddenly, around 3 am, they start to arrive — the ghosts of Shenzhen. Under the watchful eyes of local police, they carry their stock in makeshift bags.<sup>1</sup> The mood is tense as everyone seems to be waiting for something. Then, as if orchestrated by a higher power, the ghosts reveal their wares. In a choreography of bedsheets unfolding into market stalls, the *ghost market* begins.

Just around the corner on Aihua Road, there are several malls. One specializes in recycling cell phones. The other is the largest second-hand phone market in Shenzhen. Here, at night, the residue of these formal marketplaces finds its way to the street and into the backpacks of the many eager customers. To navigate under the veil of darkness requires at least a torch, but to inspect the quality of the piles of phones and logic boards available from the street vendors requires more specific tooling. Amidst the hot and noisy<sup>2</sup> crowds, numerous customers carry devices closely resembling something wielded by ghost hunters, taking readings of electromagnetic fields.

To understand what is happening here, we need to wander further into the often-ignored district of Huaqiangnan. By taking us along the flows and corners of this neighborhood, this chapter will attempt to “make sense of Shenzhen”. It is, in its own right, a bricolage of chance encounters, opportunism, fallacy, off the record interviews and numerous meanderings, accompanied by complementary academic references and illustrated by the author’s photography.<sup>3</sup> But first, we need to identify this esoteric device.

## A PORTABLE CHARGING TEST POWER SUPPLY

This tool, or “*portable charging test power supply*” (随身充电测试电源 *suishen chongdian ceshi dianyuan*) in the words of a trader interviewed in 2018, is a bricolage of consumer electronics held together by hot-melt glue or electrical tape. It is made of a USB power bank, an adaptor for the plethora of USB

1 *Makeshift bags* (*linshi xingli*, 临时行李) are often made from bedsheets—see *Floating Population* Stijns, 2013

2 In Chinese, *renao* (热闹), literally meaning “hot and noisy,” is used to positively describe the lively atmosphere of a crowded and busy place.

3 Unless stated otherwise.

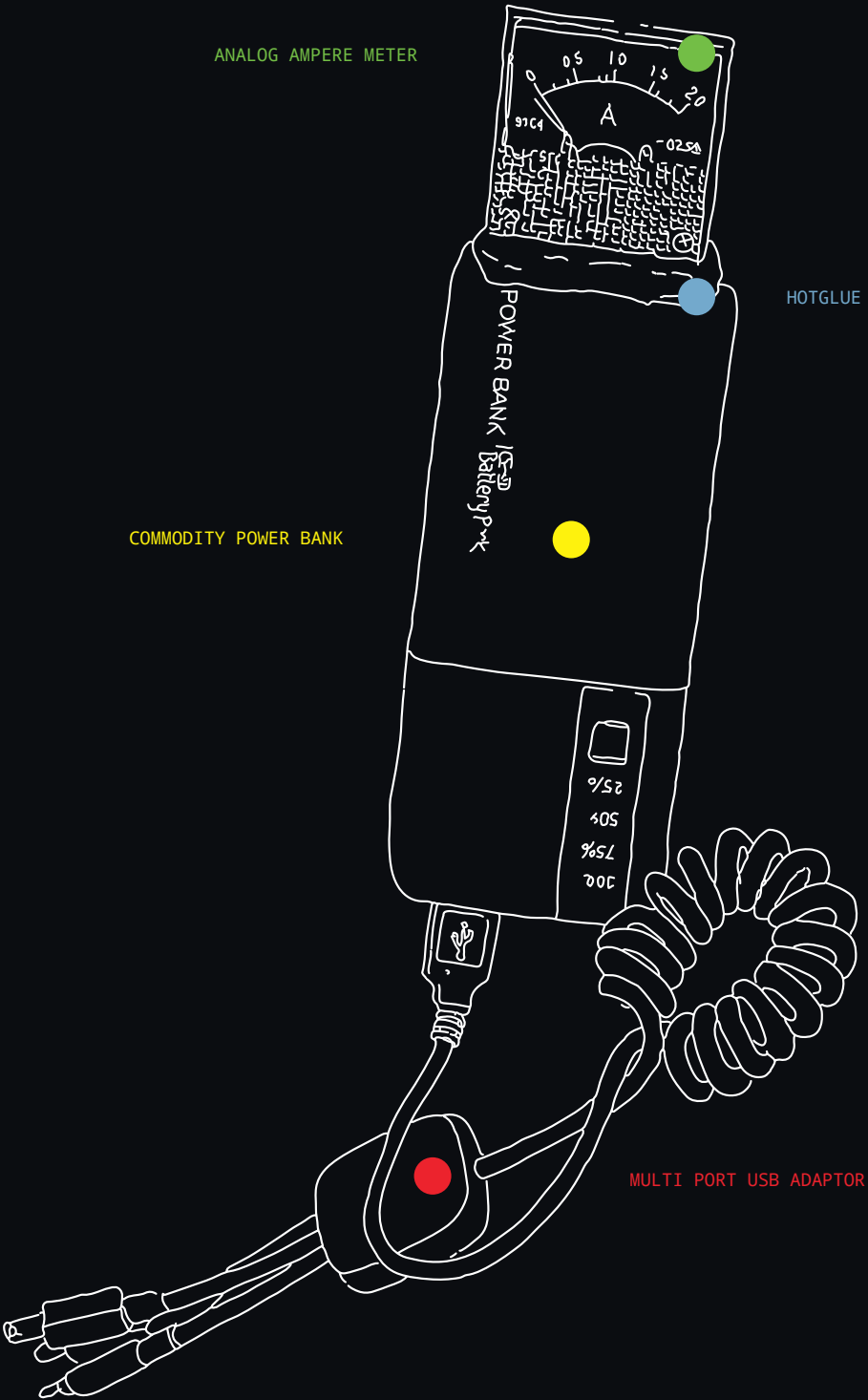

DIAGRAM OF A PORTABLE CHARGING TEST POWER SUPPLY.

variants and an analog ampere meter to measure electrical currents drawn from the bank. Sometimes it's outfitted with an extra USB LED torch for specific use at night, or alligator clips for more general testing purposes.

This tool allows the user to measure logic boards or phones for current draw. The amount of current the device draws under testing informs the buyer of the state of the device and determines the object's complex life trajectory. For example, if a device draws a current it might be in working condition, even though the screen does not light up because it is broken. When the device in question is a common model, it might be worth replacing the screen in order to sell or refurbish the unit. A high or infinite current might indicate a short circuit, while no current at all might indicate a broken phone or logic board. Depending on the model, these can be scrapped for components, raw materials or for use in improvised phones reconstructed from a multitude of scrapped parts,<sup>4</sup> commonly referred to as an “*explosive mobile device*” (炸弹机 *zhadan ji*). Eventually the phones or parts might flow towards the informal ghost market again, to start a new journey.

The tool itself is based on mobile accessories, making both the tool and the user mobile. The handheld device thus offers a certain leverage over renting an expensive desk in one of the malls and equipping it with tools. It can be defined as an *ex-commodity*, a “thing retrieved, either temporarily or permanently, from the commodity state and placed in some other state” (Maquet 1972, in Appadurai 1986)—*commodity* being used here in its widest acceptance. The commodity becomes a tool, or a part of a tool, used to assess the quality of other *ex-commodities* on sale, with the primary goal of establishing their resale value.

In *The Social Life of Things* (1986), Appadurai explains how “the flow of commodities in any given situation is a shifting compromise between (socially) regulated paths and competitively inspired diversion.” The ghost market—as well as the more formal markets in the area—exemplify this diversion process of objects becoming commodities despite being originally specifically protected from it. A case in point are factory-fresh “unpopulated” Apple logic boards, as well as schematics for the latest smartphones.

Bricolage is viewed by Michel de Certeau (1986) as the art of making-do, a process that often implies cooperation as much as competition. In Aihua Road's ghost market, we can witness both. By following the trajectories of the mysterious tool, we will unpack its flows and acts of diversions, “for their meanings are inscribed in their forms, their uses, their trajectories. The things-in-motion illuminate their human and social context.” (Appadurai 1986)

4 For example, a working logic board is cleared of all broken chips and populated with working chips from a broken logic board. An excellent example of the fact that electronics are, per definition, modular.



THE CLOSING OF *FORMAL* WHOLESALE MARKETS IS A NATIONWIDE TREND. All but one electronics market has disappeared from Beijing, but even this final holdout is said to be closing soon. Here, an image of its ground floor (2018). Centergate Como Beijing (科贸电子大厦, *Ke mao dianz dasha*) next to the Southern Longshen Market (龙胜市场南铺) in Shenzhen (2018).

## ENTERING THE GHOST MARKET

Every night since at least 2000 (Yidianzixun 2019), the *ghosts* gather to form an informal night market on Aihua Road (爱华路).<sup>5</sup> Urban markets usually bring together actors from different cultural systems, where linguistic barriers can result in unspoken *mute-trade* and other unseen forms of barter and unwritten rules. The name “*ghost market*” (鬼市 *gui shi*) possibly originates from this cross-cultural silent trade, common in the Tang dynasty (Glahn 2004). Another possible explanation is the propensity for street vendors to run away from ghosts—i.e., from law enforcement as if they have seen a ghost (Leung 2011). As of today, unwritten rules still apply in such informal markets, making research inherently difficult. First, asking where the goods come from is banned. Second, asking if the goods are genuine is considered highly impolite. As in any market, it is all about mutual trust and respectful encounters, after all. Third, don’t expect any returns or receipts.

The exact origins of the night market phenomenon in China are unclear and cover a plethora of activities, from late-night entertainment in regular marketplaces during the Qin and Han dynasties (Zhang et al. 2013) to the more fluid nightly economies of the Tang dynasty (Liu 2009). An interesting aspect is how the goods for sale reflect the territory and form unwritten accounts of socio-political histories. One origin of Beijing’s night markets is sometimes associated with the decline of the Qing dynasty where royalty, stripped of their status but not their pride, could sell their riches under the cover of darkness without losing face (Zhen 2018). This veil of anonymity also offered other elements of society the chance to rid themselves of their wares, notably antiquities looted from the many ancient tombs surrounding Beijing (Murphy 1995). While varied in nature and intention, all of these ancient nighttime activities found their roots in urban settlements and arguably exemplify one of the earliest forms of “special economic zones.”

Today’s Aihua Road market is located between decaying *danwei*-style housing and impending construction sites. The area, called Huaqiangnan, stands in marked contrast to the brand-new pedestrian street of Huaqiangbei, the global center of consumer electronics a few blocks north. The future of Aihua Road’s market feels uncertain if not impossible. Formal markets, such as TTD, colloquially known as Aihua market, are closing their doors.<sup>6</sup> Resellers in the nearby Longsheng market hall explain that business has been slowing. On the other hand, informal practices in the residential quarters are thriving. In this environment, grassroots tactics offer a space for city dwellers to manifest their expertise over the rapidly closing strategies of urban planners and developers. As such, the ghost market actually enables newcomers to make an initial capital to hire a desk in one of the formal malls as well as providing retirees with a form of income.

5 Literally the “Love China Road.”

6 深圳市通天地通讯(爱华)市场, The TTD (*Tong Tandi*) market closed May 30, 2019.



HUAQIANGBEI PEDESTRIAN STREET.  
The renovated Huaqiangbei Pedestrian Street, sporting several elevated points of interest.

Although these informal practices suggest relative autonomy from the formal market economy, an unequal power relation nevertheless exists. Only through long working hours, often in addition to formal commitments, may these tactics provide some resistance to marginalization. Furthermore, becoming a *ghost* is as relevant as ever, especially in the face of the global transitioning from *creative city* towards *smart city* (Bria and Morozov 2018).

#### HUAQIANGNAN AND HUAQIANGBEI: ACROSS THE STREET

Right across the street, the homogenized slab of smooth concrete that is the recently renovated Huaqiangbei Pedestrian Street offers a glimpse into the advance of the *smart city*. In this consumer electronics heaven, easygoing muzak playing from speaker-laden lampposts guides you gently towards shiny flagship stores. Under the influence of numerous municipal and central government policies, Huaqiangbei transitioned to “China’s No. 1 Electronics Street” in 1988 (Chang 2019), “A beautiful boulevard” in 1999 (Cheng 2015), to “Huaqiangbei Pedestrian Street” in 2017—coinciding with the *Three Dimensional Economy* plan (Urbanus 2009). Most recently, the Huaqiangbei Innovation and Development Action Plan (2017–2019) calls for the creation of a “red street, a civilized street, a cultural street and a smart street” (Futian, 2017).

Behind the futuristic facades though, one can still catch a glimpse of the Huaqiangbei once tantamount to the infamous cottage industry of *shanzhai* and counterfeit electronics (Braybrooke and Jordan 2017). Parallel to the effort to curb these practices and to China’s innovation ambitions (Fan 2016), both the term *shanzhai* and the district of Huaqiangbei have been transformed from derogatory connotations of copycat industries<sup>7</sup> to symbols of a wide range of competing aesthetics and perspectives on China’s creative economy (Keane & Zhao 2013).

On the other hand, the Huaqiangnan area is still remarkably absent from these master plans as well as from research, media and maps. Although colloquially falling under the same area as Huaqiangbei, Huaqiangnan was always administratively allocated to another urban area in the master plan—namely *Binhe* (滨河). Concurrently however, it offers a valuable example of a fully functioning *three-dimensional economy* characterized by informal practices that leverage both mixed-use zoning and a street-smart approach. Meandering from the maze of interconnected electronics markets through to extemporaneous overpasses that snake through residential dwellings, the neighborhood manifests itself as a three-dimensional bricolage of opportunistic situations. While typical of Shenzhen’s urban development (O’Donnell et al. 2018), the district was shaped by an ad-hoc conglomeration of creative disobedience deeply intertwined with official policies. Its facades, both weathered and futuristic, strikingly document this history.

7 Naturally, mass production is the act of copying.



THE AIHUA RESIDENTIAL COMPLEX VIEWED FROM THE TTD MARKET.  
This *danwei*-style neighborhood exists as an assemblage of residential housing, restaurants, mom and pop stores, commercial establishments and urban farming. Notice the SEG (*Sai ge*, 赛格) building in the background.

The core of the area revolves around the Aihua Residential Quarters (爱华住宅小区 *Aihua zhuzhai xiaoqu*). Constructed in 1979 before the opening of the Special Economic Zone, this residential area provided dormitories for the Aihua factories in the region. With no precedent to rely on, most of the planning techniques in Shenzhen were originally limited to zoning. The actual decisions and construction were left to enterprises—often state-owned (SOE) like Aihua Electronics Ltd—who were moving in first. The liberal borrowing of blueprints from either Hong Kong or the socialist *danwei* housing units resulted in a prime example of “copy-paste architecture” as still demonstrated by the Aihua Residential Quarters.

What the SOEs gained in independence through cheap land lease in the SEZ, they often lost in financial support from the government. From now on they would have to generate their own income—despite still being state owned. To compensate the loss, several SOEs started to engage in labor-intensive processing and assembly work for export. Instead of being dumped, the excess production was kept and sold to the domestic market for extra income—often known as *third-shift* production (Barbosa 2009) or *excess order* (甩单 *shuaidan*) (Fan 2018).

In the early 1990s, the Shenzhen government initialized a deindustrialization policy, pushing most manufacturing activities out of the Shangbu area to curb growing pollution. The SOEs were left with urban lands under an interdiction of production and complicated use rights related to zoning. They promptly decided to re-appropriate their now empty factories and the adjacent dormitories for commercial usage. The low rent of the still-industrial land attracted new tenants, allowing for a proliferation of informal structures. As an example, SOE Huaqiang informally converged three standalone factories into a huge commercial market for electronic components, forming the basis of what is now colloquially called *Huaqiangbei*. This fluid use of space became the basic condition for Huaqiangbei’s future success (Lam 2019). The spatial demands prompted the informal construction of multistorey, inter-building bridges, enhancing both horizontal and vertical flows.

This convergence of horizontal and vertical movement not only applies to the spatial qualities. Rather, it provides a way to approach the emergence of the various overlapping realities existing today. While common narratives on Shenzhen tend to reinforce the dichotomy of grassroots, horizontal versus the top-down, the Special Economic Zone actually enabled a conglomeration of both informal practices and top-down policies more than a purely vertical *stack*. This commonality finds its expression through the excellent device of street signs. Wandering the bustling streets, it’s easy to get caught up in the overwhelming Shenzhen speed,<sup>8</sup> while dodging fast-paced crowds to the soundtrack of ripping packing tape.<sup>9</sup> The maze of intersecting over-and-underpasses seem to make street names redundant. Yet, these prosaic navigational tools point us to where the practices of bottom-up and top-down align.

8 As sublimely illustrated by the 2014 ZTE slogan *Tomorrow never waits*.

9 JT Singh, “Tape City” <https://www.youtube.com/watch?v=zZRxJhlbgkU>

MIXED USE AROUND THE AIHUA  
RESIDENTIAL QUARTERS

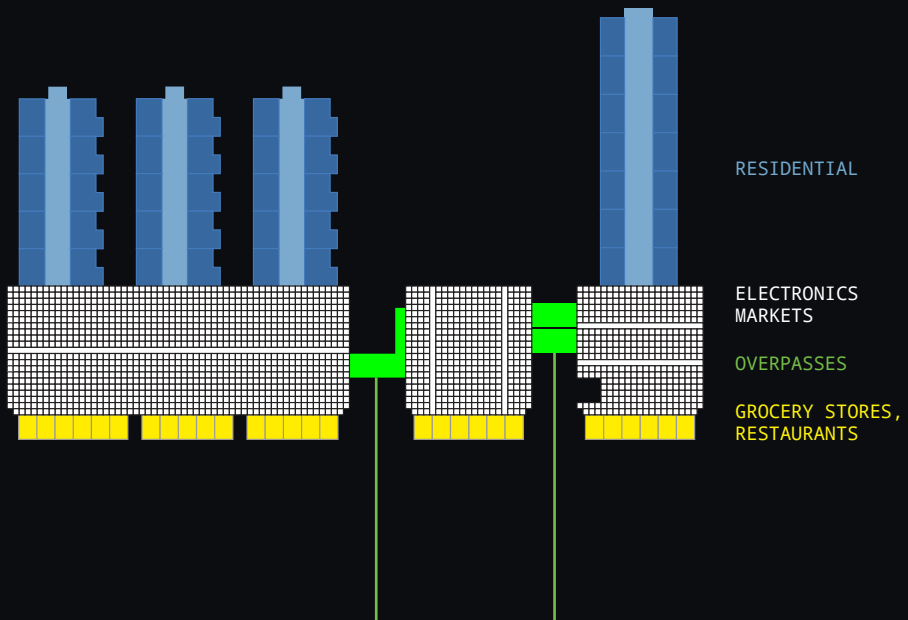

OVERPASSES.  
Overpasses linking Southern Longshen Market (龙胜市场南铺) to TTD market (通天地通讯市场) through residential areas.

CONCLUSION: THE TOP-DOWN GUERRILLA AND THE MOUNTAIN FORTRESS  
 Before the official designation as a Special Economic Zone, dozens of state-owned factories were corporatized and relocated to Shenzhen in 1979 (Cheng 2015). Notable examples, such as Zhenhua (translatable as “Invigorate China”), Aihua (“Love China”) and Huaqiang (“Strong China”) lent their names to their allocated lots as they moved in. Invoking a continuation of patriotic values, these joint-ventures were created through the reform of a preceding special zone, the Third Front (Bachman 2001).

The Third Front Construction directive (三线建设 *Sanxian jianshe*) of 1964 envisioned the creation of a self-sufficient industrial backbone, able to resist (nuclear) war amidst growing tensions with the US as well as the USSR (Naughton 1998). Deploying the proven revolutionary guerrilla strategy of *rural surrounding urban*<sup>10</sup> (Qiu 2009), factory towns re-appropriated natural fortresses like the mountains and caves of central China as shelter.

In the late 1970s, shifting priorities relocated state resources to the coastal areas. Several Third Front factories were merged into the aforementioned joint-ventures and settled in Shenzhen. The Third Front legacy is still visible in Shenzhen, where SOE landlords appropriated industrial buildings through a proliferation of informal structures interconnecting them. Moreover, the *shanzhai* culture—literally “*mountainous fortress*”—displays a compelling resemblance to the guerrilla tactics, resistance and patriotism of the Third Front: “buy *shanzhai* to show your love for our country” (Yang 2015). Like during the Yuan Dynasty,<sup>11</sup> the *bandit resistance* of *shanzhai* is vanquished by co-optation with the ruling power, finding its way into innovation discourse to reaffirm the *Shenzhen miracle* myth, with Huaqiangbei as its main stage.

Huaqiangnan, on the other hand, is nowhere to be found under the spotlights. Nevertheless, its actual setting still attests to the importance of low-scale guerrilla tactics in the grounding of larger governmental policy plans. As of today, the mixed-use development of Huaqiangnan continues to provide affordable housing and social settings that enable the basic conditions of Shenzhen’s success. Closing the gap between policies and life, the daily routine of the “ghosts” and their handmade tools reminds us that grand narratives of cities and technologies would not exist without the small-scale, negotiated tactics of humans.

## REFERENCES

- Appadurai, Arjun. 1986. *The Social Life of Things: Commodities in Cultural Perspective*. 1st ed. Cambridge: Cambridge University Press.
- Bachman, David. 2001. “Defence Industrialization in Guangdong.” *The China Quarterly* 166 (June): 273–304.

<sup>10</sup> *Nongcun baowei chengshi*, 农村包围城市

<sup>11</sup> The Chinese classic *Water Margin* written in the 13th century tells epic stories of outlaws in mountain villages, giving its original name and connotation to the term *shanzhai*.



STREET IN THE URBAN VILLAGE OF SHANG MEI LIN XIN CUN (上梅林新村). Like the Aihua Residential Quarters, urban villages offer a stepping stone, essential living quarters and community to the economically marginalized. As rapid urbanization threatens these urban villages with destruction, one can't help but ask the question: whose urbanization is this?

- Barboza, David. 2009. "In China, Knockoff Cellphones Are a Hit." *New York Times*, April 27, 2009, sec. Technology.
- Braybrooke, Kat, and Tim Jordan. 2017. "Genealogy, Culture and Technomyth: Decolonizing Western Information Technologies, from Open Source to the Maker Movement." SSRN Scholarly Paper ID 2993226. Rochester, NY: Social Science Research Network.
- Certeau, Michel de, and Steven Rendall. 1984. *The Practice of Everyday Life*. Berkeley: University of California Press.
- Chang, Bao. 2019. "1988, '中国电子第一街'华强北诞生 曾叫'上步工业区' \_深圳新闻网." *Shenzhen News*, April 1, 2019.
- Chen, Ting. 2015. "A State Beyond the State: A Study of Chinese State-Owned Enterprises' Urban Development and Transformation with the Shenzhen Special Economic Zone as Case Study." Zürich: ETH Zürich.
- Du, Juan. 2009. "Urban Myth of the New Contemporary Chinese City." *Journal of Architectural Education* 63:2
- Futian. 2017. "聚焦创新转型 第15届中国商业街年会首次在福田召开." Shenzhen.Gov. Cn. October 27, 2017.
- Glahn, Richard von. 2004. *The Sinister Way—The Divine and the Demonic in Chinese Religious Culture*. Los Angeles: University of California Press.
- Keane, Michael, and Elaine Jing Zhao. 2012. "Renegades on the Frontier of Innovation: The Shanzhai Grassroots Communities of Shenzhen in China's Creative Economy." *Geography* 53 (2): 216–30.
- Lam, Tong. 2019. "Futures and Ruins: The Politics, Aesthetics, and Temporality of Infrastructure." *Made in China Journal* (blog). July 22, 2019.
- Leung Yin Ling. 2011. "Disappearing Hawker Culture." *Cultural Studies@ Lingnan* 25.
- Morozov, Evgeny, and Francesca Bria. 2018. "Rethinking the Smart City." City Series, #5. New York: Rosa Luxemburg Stiftung.
- Murphy, J. David. 1995. *Plunder and Preservation: Cultural Property Law and Practice in the People's Republic of China*. Hong Kong; New York: Oxford University Press.
- Naughton, Barry. 1988. "The Third Front: Defence Industrialization in the Chinese Interior." *The China Quarterly* 115 (September): 351–86.
- O'Donnel, Mary Ann, Winnie Wong, and Jonathan Bach, eds. 2017. *Learning from Shenzhen: China's Post-Mao Experiment from Special Zone to Model City*. Chicago: University of Chicago Press.
- Qiu, Jack Linchuan. 2009. *Working-Class Network Society: Communication Technology and the Information Have-Less in Urban China*. Cambridge, Mass: The MIT Press.
- Urbanus. 2009. "华强北立体街道城市设计 2009." Urbanus. 2009.
- Yang, Fan. 2015. *Faked in China – Nation Branding, Counterfeit Culture, and Globalization*. Global Research Studies. Bloomington: Indiana University Press.







# LEARNING ABOUT MAKERS IN CHINA

---

中国创客调查实录 | Monique Bolli, Clément Renaud, Anaïs Bloch & Emanuele Protti

---

This chapter will introduce an experiment in fieldwork methods conducted to investigate China's fast-transforming spaces for "making" and tinkering with digital manufacturing. Through multidisciplinary workshops organized in Renens in May 2017 and in Shanghai and Shenzhen in March 2018, this experimental approach aimed to overcome issues faced by traditional participative ethnographic methods—to deconstruct and reconstruct the research object—while studying phenomena where knowledge and practices evolve locally, but also online, across cities and international networks.

From Do-It-Yourself (DIY) communities to industrial research and innovation, a redefinition of the processes of making has emerged globally under the name of the *maker movement*. Making, traditionally considered an essential means of cultural transmission and learning (Ingold 2013), has been separated since the 19th century from other cultural activities, in order to follow the structural division of industrial production. Questioning this separation, *makers* want to reconsider the act of making as an instrument for knowledge transmission and community engagement.

Around the world, various initiatives have been created to support this trend, gathering groups of stakeholders from local communities, governmental offices, universities, institutions, businesses, etc. Locally, the makers tend to meet in specific places often known under terms such as *fablabs*, *maker-spaces*, *hacker-spaces*, etc. While these words have already gained momentum (see section 2), their existence is hardly homogeneous, as their role and characteristics echo the sociocultural, political and technological settings in which they take place.

In Chinese cities, the industrial transition from low-cost to higher-margin production of services and technologies has led to major urban transformations. Here, the spaces of the makers offer an interesting sneak peek into these changes. Iconic places such as *xinchejian* in Shanghai or *x.factory* in Shenzhen have become an integral part of those cities' industrial strategy, with visits and sometimes partnerships with top officials and leading industrial actors across China and abroad.

The entanglement of discourse and projections from the different stakeholders turns the study of this phenomena into a complex problem—increased in China by the speed of urban change in recent years. In this chapter, the authors explicate



FIELD RESEARCH.  
Electronic market of Huaqiangbei, Shenzhen, 2018

their methodological attempt to consider not only the local whereabouts of specific places, but also their entanglements in larger municipal, national and global networks. The text begins by giving some context about makers in China before introducing existing theories and approaches of studying changing spaces. It continues with a detailed description of the experiment which included participatory public events, on-site multidisciplinary fieldwork and the making of a small booklet during a ten-day workshop in China. The chapter ends with a discussion of the main takeaways, learnings and shortcomings of our approach, as well as recommendations.

#### MAKERS, MAKERSPACES AND CHINA

In recent years, the cost of industry-grade tools (numerical control machining, additive manufacturing, electronic sensors or microcontrollers, etc.) has been decreasing rapidly, facilitating the access of small organizations and individuals to these resources. At the same time, the surge in online activities worldwide has made vast arrays of learning materials available for tinkering with technologies, with the central example of open-source software and electronics. This new distribution of information and tools has had major strategic implications for companies and entire industries whose development has traditionally relied on their edge in technological innovation.

Inventors, entrepreneurs, students, scholars, journalists, policy-makers... multiple groups of people have tried to define, discuss, claim and describe this growing trend. In 2011, Anderson—a famous Californian editorialist—popularized the term “maker movement”, describing how “makers” were taking advantage of these new opportunities to lead a new “industrial revolution” that would radically transform the practices of manufacturing, business and education. At its core, making was defined by Anderson as a hands-on approach in defining new economic pathways (Anderson 2012). While this definition quickly gained momentum with policy-makers and executives, epistemic communities also formed around the newly available materials and devices to pursue their interest for design and experimentations. For these communities, making was framed as a form of empowerment and resistance to consumption and mass production, where situated creativity would prevail over economic incentives (Dougherty 2016).

All over the world, vastly different practices and communities have organized—or been grouped—under the unified umbrella of a maker movement or maker culture. Diverse appellations (hackerspaces, fablabs, makerspaces, etc.) have emerged to qualify different organizational and business models, as well as goals and connections to larger (global) networks (Capdevila 2017). For the purposes of this study we will rely on the general term *makerspaces*, defined as shared spaces or workshops that loosely associate themselves with the maker movement and provide tools, tables and chairs for regular members’ meetings and/or public events.

In China, early makers positioned themselves as part of this seemingly global movement. A loose translation of the term maker, the Chinese term *chuangke* (创客), was created by China’s open-source hardware advocates to position their



FIELD RESEARCH.  
Drawings by Anaïs Bloch, Shenzhen, 2018

work within the global and national dynamic of innovation, entrepreneurship and creativity discourse (Lindtner 2015). This fairly young term was later endorsed by Chinese Prime Minister Li Keqiang in 2015 as part of the ten-year plan on industrial and economic reforms *Made in China 2025*. Once indicating a local community member, *chuangke* came to describe the figure of a young, active Chinese tech entrepreneur.

Following this announcement, makers in China were propelled to a new position of innovation leadership with the mission to reboost and diversify the national economy, both locally and abroad. Continuing on from previous plans to foster innovation and creativity through urban development (Keane 2006), the government targeted innovations coming from communities and individuals to transform China's image from "the world's factory" into an "innovation-oriented nation" (Lindtner 2017). As Wang (2016) writes, the Chinese makers inherit a double identity—or a single identity with a double activity: the entrepreneur and the activist.

In 2010–2011, makerspaces started to appear in China (Bolli 2020; Renaud 2018). Like in many other cities, these spaces were originally created by hobbyists and professionals willing to share space, tools and ideas to grow their projects. Members would usually pay a monthly or yearly fee for access and volunteer to help run the space. Regular public workshops were organized by members to share their skills, create an income and give visibility to the space.

In 2015, a large public investment policy called *Mass Innovation, Mass Entrepreneurship* (众创 *zhongchuang*) transformed the landscape of making in China (Wen 2017). Benefitting from subsidies, new spaces appeared (and sometimes disappeared) in cities all over China. Small organizations and spaces that existed prior to public intervention often faced unplanned and even difficult situations due to the rise of public interest and attention. Spaces opened and closed, people joined and left, organizations changed or disappeared. City governments in Shenzhen or Shanghai supported the emergence of Chinese public figures and companies as representatives of the global maker movement.

Beyond the maker-enthusiast, makers are now at the forefront of China's industrial strategy to position itself as a strategic hub and exporter of innovation in manufacturing, with support from large international industrial firms such as Apple or Tesla and programs like the Belt and Road Initiative. Therefore, maker-spaces are interesting places to observe and document the encounter of China's top-down policies with a vast array of local and global stakeholders.

## HOW TO STUDY CHANGES IN COMMUNITY SPACES?

### COMPLEX FIELDWORK AND MULTIDISCIPLINARITY

There are many challenges to such a study. First, China's urban and industrial development comes in all kinds of scales and varieties. The diversity of the country and its size makes any generalization pointless. Second, the pace of transformation and evolution one can witness on the ground makes traditional



FIELD RESEARCH.  
x.factory makerspace, Shenzhen, 2018

inquiries very difficult. Third, the “maker movement” stands at the crossroads of major economic and industrial interests, and therefore is subject to lots of attention. The multiple discourses, statements and actions surrounding it are motivated by incentives and intentions, which are not always easy to discriminate.

Still, studying makerspaces is a unique opportunity to observe China’s urban and industrial transformation through actual spaces created by communities—as well as interactions between people, space and state in China. As small organizations, makerspaces face significant sustainability challenges. Their existence relies on the support of members, public and private stakeholders, as well as their place in a larger socioeconomic ecosystem (Kingsley & Saunders 2016). The entanglement of the lifepaths of these organizations and their members makes tracking changes challenging, especially in short windows of time when maintaining contextualization and cultural sensitivities is already difficult. Traditional methods of ethnographic inquiry such as on-site participatory observation show their limits in the face of these multifaceted objects that exist altogether in local, national and international discourses, places and networks.

There is therefore a need to develop research methods that can apprehend fast-changing, multilayered and multisited fields of research (Marcus 2016). Researchers have been keen to rely on the participation of local stakeholders to help them grasp reality. Still, Cornwall and Jewkes (1995), who discuss the notion in the context of health research, remind us that: “‘Participation’ is rapidly becoming a catch-all concept, even a cliché. ‘Participatory’ research methods can be used not only to enable local people to seek their own solutions according to their priorities, but also to secure funding, to co-opt local people into the agendas of others or to justify short-cut research within a top-down process” (Cornwall & Jewkes 1995). In the context of makerspaces in China, we relied on our familiarity with many stakeholders (evolving from long-term involvement with the topic and local communities) to allow them to voice their ideas at several levels of the process and acknowledge their influence in the construction of the research narrative (Clark et al. 2009).

The study of complex social realities can also be improved by having experts with different backgrounds, knowledge and research specialties (Ramadier 2004). The involvement of experts from different fields, besides comprehending the different disciplinary points of view on the subject enquired, helps to disassemble and reassemble an acquired knowledge. The capacity to look at things from a different perspective helps to compare, contrast, differentiate, clarify and synthesize the complex reality analyzed. As Hine (2007) explains, interdisciplinary methods can also be problematic, by making the formulation, validation and communication of the research more difficult. Therefore, the team should be careful to preserve the disciplinary thinking of each member (Ramadier 2004).



Ultimately, this disassembly of global “assemblages” is made possible by active dynamics and exchange between the practitioners (researchers or participants). The building of strong and meaningful relationships becomes an essential—and often underconsidered—component of the research. To create boundaries and share practices through common activities becomes an important way to develop common knowledge and experience. In our case, hands-on workshops were central to exploring the craft and tools of the makers (Marshall and Rossi 2017).

Short-term and multisited research such as the example proposed in this article also have to rely on extensive local knowledge to develop a chronology of the “new worlds” in the “global cultural flow” (Appadurai 1990). Therefore, we decided to lead our research by combining short intense actions (such as workshops) and longer time spans (for literature and fieldwork). Two members of the scientific team spent several months on-site to develop networks, specific language skills and cultural sensitivity. Meanwhile, we also created specific moments to act as stepping stones for a larger understanding of our topic.

As we were dealing with objects with strong spatiotemporal constraints (and being also far from China), we decided to design the research project through the rhythm of successive events allowing us to build up the framework and the network. All the research design was made by a core multidisciplinary team of four researchers (anthropology, geography, economics) which was further extended during workshops (sociology, design, architecture, etc.). A first prefiguration workshop was held to explore and refine the methodology. Then, extensive time in the field in several cities in China (Beijing, Shanghai, Chengdu, Shenzhen, Hong Kong) was necessary to build sufficient knowledge about local circumstances and stakes. Finally, we conducted participatory workshops in two different cities to confront our observations with local stakeholders.

#### PRELIMINARY RESEARCH AND PREFIGURATION WORKSHOP

The first prefiguration workshop entitled “*How to study makerspaces?*” took place on May 18 and 19, 2017 in Renens, Switzerland. For two days the researchers were hosted at *Les Ateliers de Renens*, an old printing factory repurposed into a creative cluster hosting a makerspace, a fablab, a bio-hacklab and a coworking space. An important advantage of this location was the multiplicity of types of spaces under the same roof, as is often the case in China. It fosters a comparative perspective. The workshop brought together 15 researchers, makers, practitioners, and political and educational representatives from different backgrounds and disciplines with the goal of designing new methods, processes, protocols or tools that could support the study of makerspaces.

Most participants were postgraduates or young researchers and practitioners—a deliberate choice as most academics seem to become less prone to experimentation as their careers advance. There were no formal presentations, rather time was divided into short work sessions of discussion, field exploration of the location, hands-on prototyping or online/offline experiments. The goal for



FIELD RESEARCH.  
x.factory makerspace, Shenzhen, 2018

participants was to conceive elements or methods that could later be used in the field in China. We tested prototypes of the methods in teams. At the end of the workshop, the results were presented during a public event.

This first workshop allowed us to experiment with new ways to observe, record and map activities, changes, discourses and stakes that surrounded the space. Open questions such as “How to constitute a documentation of activities in a makerspace,” “How to co-create research that is useful for the maker communities” and “How to lead workshops as forms of investigation” were shared and discussed. Different methods (creative interviews, network mapping, comparative study across multiple spaces) were tested in small groups to identify potential challenges while collecting, discussing and interpreting the data.

These three days allowed us to gather information and approaches for the on-site workshops, which would take place ten months later in March 2018 in Shanghai and Shenzhen. Several important elements came out of these initial sessions: the importance of pre-existing connections for a constructive exchange with space tenants; a clear communication and intervention strategy in order to obtain interviews; the ability to identify the different actors present in the spaces (practitioners, educators, managers, investors, researchers, etc.) as well as the levels of interaction (makerspace, city, international, etc.); and finally, the importance of creating a final event to share collected information and widen the network.

These early findings helped to elaborate a more critical view, allowing distance and a comparative approach for later steps of the project in China. Deconstructing research practices in this context allowed us to reconstruct them while integrating the Chinese context during the second workshop.

#### THE MAPMAKERS’ WORKSHOP IN SHANGHAI AND SHENZHEN, CHINA

A popular way to explore China’s maker realities is the organization of on-site “learning experiences.”<sup>1</sup> Considered as both research and learning experiments, students and curious participants (from random enthusiasts to qualified scientists) come for short discovery sessions lasting usually a week or two, packed with visits to key locations and encounters with important figures and organizations of the maker movement. These short and intense experiences are often co-organized by Chinese and international entities whose aim is to discover and learn, as well as to potentially promote their own products and services. This common practice resonates with the propensity of members of the maker community to travel and organize events abroad as a way of meeting and interacting

1 Educational, explorative or entrepreneurial trips organized by various actors, for example: China Hardware Innovation Camp (CHIC), an educational project, initiated by École Polytechnique Fédérale de Lausanne in Switzerland; Hello Shenzhen, a bilateral residency exchange program connecting makers in the UK and China supported by the British Council; Noisebridge trips through makerspaces in China initiated by Mitch Altman, founder of Noisebridge Hackerspace in San Francisco, USA; high tours organized by x.factory makerspace in Shenzhen, China, to discover the Shenzhen ecosystem.

SHEZHEN  
SHENZHEN

07

03

WOKSHOP  
WORKSHOP

2018

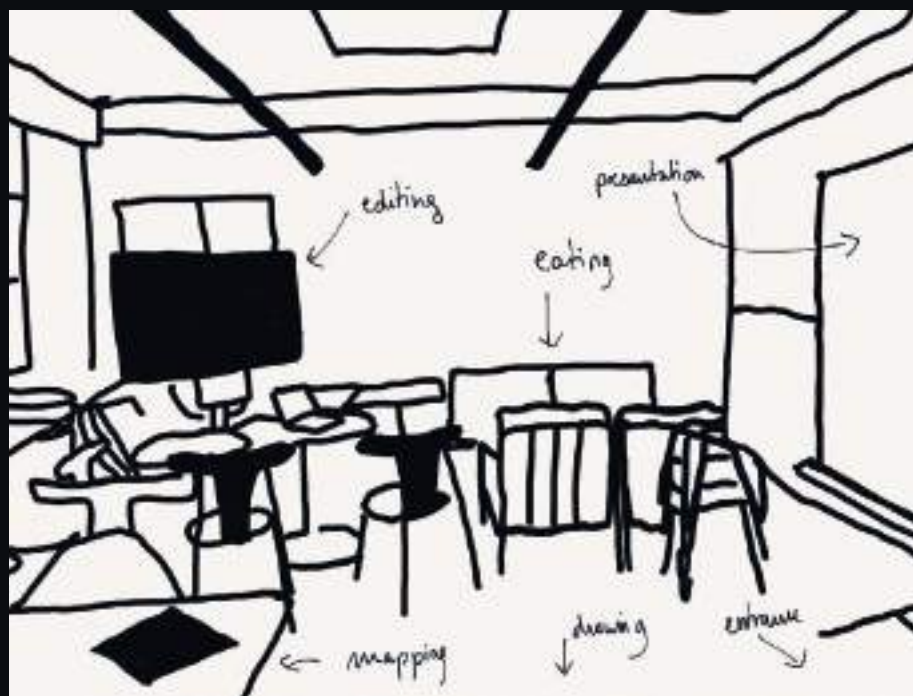

FIELD RESEARCH.  
Drawings by Anaïs Bloch, Shenzhen, 2018

with local communities. These visits were frequently mentioned in interviews, and appeared in many ways to be related to the construction of national and international narratives about maker communities in China.

To revisit these experiences, we decided to organize and conduct a ten-day on-site research session across different spaces. The *mapmaker* workshop took place from March 1 to 10, 2018 in Shanghai and Shenzhen. It was led by a scientific team consisting of a social anthropologist, an urban geographer, a designer, an architect, a professor of China's urban studies and an economist specializing in innovation in China. The participants had met during the preliminary workshop in Renens, which allowed a continuity of experience. Among the team of experts, four of the researchers had extensive experience on the topic, and of China. The two main organizers had conducted comprehensive research and were well-acquainted with active local networks. The two others (namely the designer and architect) were unacquainted with China, but were active in studying maker culture in Europe.

Following an initial phase of organization and the sharing of objectives among the different members of the group, the experience consisted of two sessions of five-day fieldwork in makerspaces (one in Shanghai, one in Shenzhen). In each city, the last day was dedicated to a free presentation event in a public space where early results of the workshop—and the whole research project—were presented and discussed with participants. To recreate an understanding of the multisited field of research, the experiment started in Shanghai—where the first makerspace in China opened in 2010—and ended in Shenzhen—where China's maker culture exports itself to the world.

In each city, the team visited an average of six to seven spaces over the course of five days. The multidisciplinary team made use of different disciplinary methods, techniques and skills to produce images, maps and drawings, as well as holding interviews and discussions with stakeholders. The collection of research material was organized strategically among the team members according to their specific skills. Each visit or interview was followed by a short debrief and exchange of views. The focus on two main constituents of the investigation—space and actors—was useful in confronting the different (disciplinary) points of view. In particular, drawing and mapping by the designer and architect proved to be very useful when carrying out later analysis about objects, settings and atmosphere in a space. Note-taking and interviewing were also invaluable in recollecting precise knowledge about actors, whereabouts and history of the organizations.

To conduct the mapping, questions with precise angles were defined beforehand: “How is the space organized and where is it located?” “What are its dimensions and common furniture?” “What type of machinery is used and how are they organized in the space?” The team decided to rely on phones and tablets for acquiring and processing information. Measurement and digital hand-drawing apps were used, as well as more traditional instruments such as laser rulers, graph/drawing paper, and a professional camera for photos and videos. Although



FIELD RESEARCH.  
X-space, Shanghai, 2018

digital tools require greater care to avoid errors, digital sketching tools allowed rapid graphic reworking and instant use of the documents—especially for the purposes of public presentations.

An important part of the work was to organize things online (Wilson & Peterson 2002). A website<sup>2</sup> acted as a repository for each event or workshop organized with shared data, pictures and text. From the first website announcement, to long-lasting discussion groups initiated during the workshop, the wealth of digital channels of communication, publication and archiving allowed the workshops to be organized smoothly. For each city, we created discussion groups<sup>3</sup> for public announcements about the sessions and discussion or link sharing. Reflecting on the popularity of messaging apps in China, multiple chat groups were instrumental in managing the logistical and practical aspects of the on-site organization, but also to create an additional participatory space for discussions and relationships—for instance with people unable to join the events. Some groups largely outlived the workshops, with active exchanges with and between local stakeholders occurring more than a year after the events, usually in order to share information and advertise events and promotions.

The public presentations in Shanghai and Shenzhen happened in partnership with local venues. While we were originally expecting the stakeholders we had already met to come, few actually took part in the events. Instead we had a diverse crowd of 20–30 people interested in *making*, with various levels of knowledge and acquaintance with the topic. Many participants were active members of organizations in their free time, shaping new ways of working and thinking and were interested in learning from the maker culture and to connect with each other and share their experiences, which also allowed the researchers to collect information on the perception and knowledge about the maker culture locally.

The afternoon of the first event was dedicated to exposing data and our early findings to the public. While researchers could fine-tune their analysis and gather feedback and expertise from audience and teammates, newcomers could discover a new field and present their insights. We compared the data collected (pictures, interview notes, drawings and maps) as well as our ideas and insights, but above all we shared the experiences gathered on-site during visits and interviews. Finally, these public events were a chance for the team members to present their personal research, the methodologies used and their results, and to broaden the spectrum of discussion. Pictures and notes were also made during the public presentations, which were documented and published on the website of the research project and shared in the WeChat groups. Rather than being limited to the direct settings, the learning provided lots of useful contextual and experiential knowledge. The goal of these sessions was to learn “*with*” the material ecosystem of interest (Ingold 2013), and therefore the last day was dedicated to binding everything together by making a small book.

2 The project’s website: [mapmakers.space](http://mapmakers.space)

3 We used Tencent WeChat, the main communication channel and network in China.

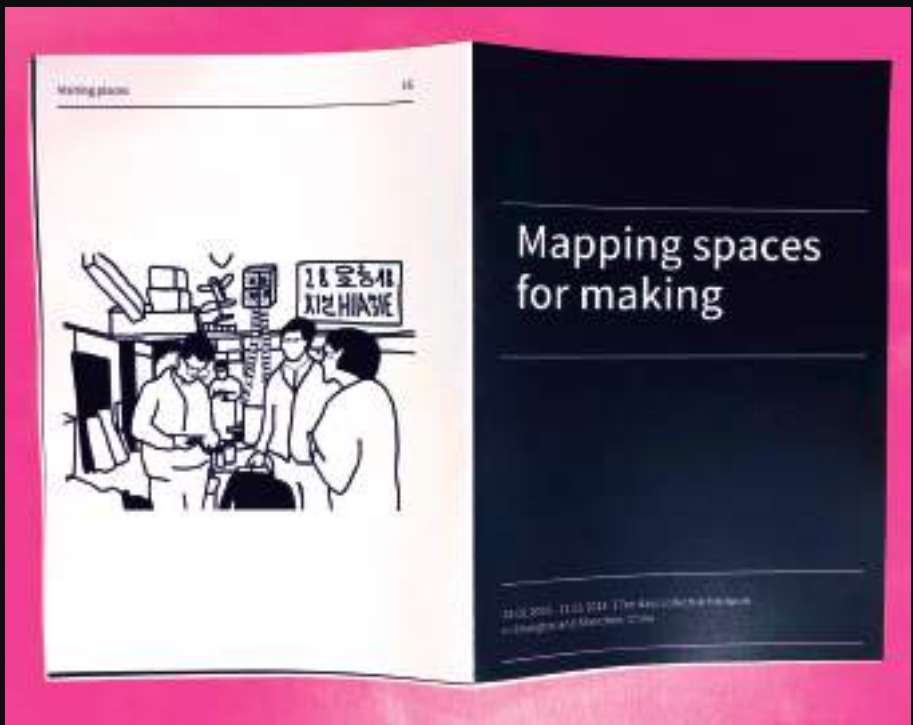

BOOKMAKING WORKSHOP.  
Shenzhen Design Center, 2018

## BINDING IT TOGETHER, MAKING A ZINE

“Learning-by-doing” is one of the foundational pillars of the discourse and practices of maker communities. Indeed, what better learning process than doing things yourself?

As our goal was to explore how things are made in China, we decided to make something with a local audience. This experience would be an opportunity to enter the practices and discussions associated with a more hands-on exchange. Makers make all kinds of objects but researchers mostly make books. Therefore, we decided to make a booklet—a zine<sup>4</sup>—in the short time span of the investigation. To better understand the legendary *Shenzhen speed*, in the city where products rise and fall in a matter of days, the team ambitiously decided to make this zine during the final day of the session. After eight days of fieldwork, we selected materials, defined a plan and produced a booklet. It was a long day and a late night, spent with computers, hammers and whiteboards in one of Shenzhen’s makerspaces.

During the whole trip, we also tried to encourage remote contributions to the zine by setting up an online writing tool. Despite receiving a few submissions, the online platform turned out to be difficult to manage. First, providing guidance, answering questions and reviewing content from distant participants generated a large communication overhead—something that had already peaked with the numerous chat groups. Second, the choice of the tool itself was not really appropriate. Git—a popular source management platform in the world of computer development—was chosen to store and accept contributions. Makers are reputedly tech-savvy enough to know about Git, but it turned out that those eager to write texts were not always those tech-savvy makers—who may prefer to code. The difficulties of the writing interface prevented it from becoming more meaningful for the publication process.

The aim of the zine was not to compile fully written analyses—scientific writing requires time to mature. The goal was to capture the raw energy that drives makers in Shenzhen by putting ourselves in similar condition—and conversationally putting together a first prototype of the present book. The zine was finalized at the Shenzhen Open Innovation Lab (SZOIL) on the night before the public event, which took place at the Shenzhen Design Center. In the morning, we produced 300 color copies of the final version of the zine at a local print shop, that would later be bound together into a few dozen zines during the afternoon. Participants from many different backgrounds began to arrive at the event venue around 2 pm. High-school students, scholars, architects, hardware designers, NGO members: a very diverse crowd was in attendance. The topic of this workshop was *Web-to-Book Binding*. After compiling and printing the pages, the last step in releasing our proto-books was to bind them together. Our team provided all the materials required for book-binding (tools, cover, stamps, wire, scissors

4 Short for magazine, a *zine* is a small-circulation self-published work usually photocopied and generally circulated within counter-culture movements.



and more), bought in the morning in the surrounding shops. After presenting the project, and after the participants presented themselves individually, the real manual work started: making the book!

Most handcraft workshops require each participant to create her/his own book following a step-by-step procedure described in a tutorial or by a teacher. For ours, we wanted to ask the question: how do we learn as a group? We selected a traditional Chinese technique of book sewing that required several complex manipulations. Despite having instructions, few of the participants had ever done any book binding previously. Instead of having each person make their own booklet from zero to end, the work was divided into tasks: assembling the pages, drilling holes, cutting the cover, measuring string, sewing the pages—and, of course, constant quality control to improve the process as the product progressed through the different stages. Each task was separated onto a different table, forming a small assembly line where everyone could change role at any time. In less than two hours, we made 31 books with lots of dedication, mistakes and laughter.

Some participants experimented for the first time sewing and hammering. Beyond the personal experience, the goal was set so every person would be able to go home with their own copy of the book—and that everyone had learnt how to make books as a group. Once all the books were produced, we closed the workshop with a talk about another handcrafted book about maker culture in the region (Poon 2018). The participants—as well as our team—were satisfied with both the group dynamic and the work achieved in such a short amount of time. The making of the book led to interesting discussions about how manual work is regarded in China, the difficulty of access to the ideas of the maker, and the difficulty of making something without prior support or education in manual work.

## DISCUSSION

The diversity of participants involved in this research, from multidisciplinary research teams to public events, made for a complex and fascinating experience that brought to light several elements for reflection in the renewal of fieldwork methods. The focus on making an actual object as a *group* provided a lot of feedback and a large amount of empirical learning in a short amount of time. The focus on real-time action (through timed workshops and events) allowed us to get a grasp on fast-changing spatial and urban resources intervening in the building of a maker culture—by shaping the experience when pressure is building as product delivery nears. This was especially suited for a study about makers, where stakeholders are usually willing to test, learn, join, try, fail and share knowledge and know-how.

Learning from experimental approaches allows for diverse opinions and ideas to exist untested first, before finding their place, or being discarded, as empirical knowledge and networks are built. One of the unique points of this experiment was the ability to lead fieldwork as a group. Multidisciplinarity existed not as a



# Mapping spaces for making

10.01.2018 - 10.02.2018 | The days creative business  
In Shanghai and Shenzhen, China

theoretical approach but as an opportunity to combine skills and approaches to maximize focus during the short timespan of the visits, interviews or events. The reliance on common goals, defined together beforehand, helped each member of the research team to focus on his/her specific craft (maps, interviews, drawings, etc.) and to benefit from the common discussions and the material produced afterwards. Another key form of complementarity was the difference in familiarity with the actual field itself—Chinese cities. Expertise and more naive takes were useful in identifying blind spots and traversing different levels of discussion and reflection.

The program initially prepared was largely adapted to the occurrences of fieldwork. In many regards, the methodology inductively emerged from the field. Still, the reliance on extensive prior on-site research allowed adaptability and protected against too much randomness in the selection of local investigations. This ad-hoc design also provoked a gap between the initial plan and its realization, i.e., the participants of the public workshops were not makers but people interested in making, the proposition of online writing largely missed its target. Online organization had a deep impact, and as such constituted an integral part of the research methods. In a short amount of time, participants of the discussion groups were able to share links, pictures and feedback.

The public events forced the researchers to explain, show and demonstrate research by creating common maps with various stakeholders. Asking questions about lifepaths and listening to personal stories helped remove the gaps, highlight the information and confirmed or disconfirmed the original sets of hypotheses. Learning with—or through the eyes of—the learners widened the scope of understanding, and helped to consolidate and share knowledge. Local users and actors were able to actively share their experiences and learn from our research during interviews, visits and public events. This active interaction enabled not only the re-framing of the research questions but also a rethinking of the outcomes of the research, involving non-academic stakeholders through specific workshops and fieldwork.

As a result of these workshops, the focus of the research project became larger and included more elements of urban and spatial mapping as well as more creative approaches (hand and iPad drawings, zine making, mapping, picture staging of objects, etc.). Also, as the main participants of the public events were not makers, the team had a great chance to learn about (and share) the perception of the maker culture from (and with) non practitioners. The participants were all gravitating, with their own interests, to these places, bringing and opening positive dialogues as well as networking happily.

Concentrating the research—based on previous fieldwork, data collection and analysis—on an intense ten days of interaction with local communities helped to create a two-sided discussion with the participants and stakeholders on the spot. At the same time, the imperative of the fieldwork led to multiple theoretical and practical multidisciplinary exchanges between the research team. Bringing



MAPPING SPACES FOR MAKING, SHANGHAI & SHENZHEN 2018 (ZINE).  
Graphic design: Anaïs Bloch & Emanuele Protti

external contributors with the research team helped prevent field fatigue and was useful in spotting questions that appeared obvious to researchers familiar with the field, but required thorough thinking.

Through all of this, human encounters appeared to be at the center of the design of this experiment. The understanding of places varied according to these encounters, as well as our capacity to grasp and evolve in the networks of makers in the main Chinese cities. While prior expertise was instrumental in the ability to enact such an experiment, relationships within and outside the research team played a central role in enabling or preventing part of the initial intentions to succeed.

## CONCLUSION

The aim of this chapter was to share a multidisciplinary learning experiment in the context of a broader research project about makerspaces in China at École Polytechnique Fédérale de Lausanne (EPFL).

Studying makerspaces in China is complex and challenging due to the rapid evolution of Chinese cities and the ephemerality of the spaces themselves. A first workshop was organized in Renens, Switzerland in May 2017 with a group of 15 researchers from different fields to explore and test multidisciplinary methodological approaches for the study of makerspaces. Based on learnings from this first event and months of field experience in China, a second workshop was organized in Shanghai and Shenzhen in March 2018. This ten-day workshop was an opportunity to revisit spaces, complete data, learn from and with stakeholders during public events in each city, dedicated to knowledge sharing and the making of a small booklet about the experiment. This on-site research was conducted as a team, with two participants from the first workshop, completing the disciplinary variety of the initial team (anthropology, geography, economics, design, architecture).

While this experiment was designed to fit the maker culture and environment, the protocol could be adapted to other contexts and projects to share and confront early findings, hypotheses and reflections with local stakeholders. These elements of the method are particularly suited to the context of complex, multifaceted objectives, as they can help to complement systematic approaches to fieldwork with the depth of direct experience.

## REFERENCES

- Anderson, C. 2012. *Makers: The New Industrial Revolution*. (1st ed). New York: Crown Business.
- Appadurai, A. 1990. "Disjuncture and Difference in the Global Cultural Economy." *Theory, Culture & Society* 7, 2–3, 295–310.
- Bolli, M. 2020. *Liminality, Ephemerality and Marginality with Impact: Makerspaces in the Chinese Urban Fabric* (Unpublished doctoral dissertation). École Polytechnique Fédérale de Lausanne, Lausanne, Switzerland.
- Capdevila, I. 2017. "5. A Typology of Localized Spaces of Collaborative



FIELD RESEARCH.  
Drawings by Anaïs Bloch, Shenzhen, 2018

- Innovation.” In *Entrepreneurial Neighbourhoods: Towards an Understanding of the Economies of Neighbourhoods and Communities*, edited by Maarten van Ham et al., 80–97. Cheltenham: Edward Elgar Publishing.
- Clark, A., C. Holland, J. Katz and S. Peace. 2009. “Learning to See: Lessons from a Participatory Observation Research Project in Public Spaces.” *International Journal of Social Research Methodology* 12, 345–360.
- Cornwall, A. and R. Jewkes. 1995. “What Is Participatory Research?” *Social Science & Medicine* 41, 1667–1676.
- Hine, C. 2007. “Multi-sited Ethnography as a Middle Range Methodology for Contemporary STS.” *Science, Technology, & Human Values*.
- Ingold, T. 2013. *Making: Anthropology, Archaeology, Art and Architecture*. London: Routledge.
- Keane, M. 2006. “From Made in China to Created in China.” *International Journal of Cultural Studies* 9, 285–296.
- Kingsley, J. and T. Saunders. 2016. *Makerspaces and the Search for Mass Innovation*. Nesta – British Council.
- Lindtner, S. 2017. “Laboratory of the Precarious: Prototyping Entrepreneurial Living in Shenzhen.” *WSQ: Women’s Studies Quarterly* 45, 287–305.
- Lindtner, S., A. Greenspan and D. Li 2015. “Designed in Shenzhen: Shanzhai Manufacturing and Maker Entrepreneurs.” *5th Decennial Aarhus Conference on Critical Alternatives* 85–96.
- Marcus, G. E. 2016. “Multi-sited Ethnography: Notes and Queries.” *Multi-Sited Ethnography*. Retrieved September 2, 2019, from taylorfrancis.com website.
- Marshall, Justin, and Catharine Rossi. 2017. “Making with China.” *Digital Culture & Society* 3 (1).
- Ramadier, T. 2004. “Transdisciplinarity and its Challenges: The Case of Urban Studies.” *Futures* 36, 423–439.
- Renaud, Clément, Valérie Fernandez, Gilles Puel, and Feng Zhen. 2018. “Urban Modes of Assemblage: The Changing Spaces of Innovation in Shanghai.” *Management International Review* 23 (3): 131–40.
- Shea, P. and G. Xin. 2018. “Makerspaces and Urban Ideology: The Institutional Shaping of Fab Labs in China and Northern Ireland.” *The Journal of Peer Production* 78–91.
- Wang, J. 2016. “The Makers Are Coming! China’s Long Tail.” In *Handbook of Cultural and Creative Industries in China*, edited by M. Keane, 43–63. Cheltenham: Edward Elgar Publishing.
- Wen, W. 2017. “Making in China: Is Maker Culture Changing China’s Creative Landscape?” *International Journal of Cultural Studies*.
- Wilson, S. and L. Peterson. 2002. “The Anthropology of Online Communities.” *Annual Review of Anthropology* 31, 1, 449–467.

[07] CHINA.AI 人工智能.中国 [07] CHINA.AI  
能.中国 [07] CHINA.AI 人工智能.中国 [07] C  
人工智能.中国 [07] CHINA.AI 人工智能.中国  
HINA.AI 人工智能.中国 [07] CHINA.AI 人工  
能.中国 [07] CHINA.AI 人工智能.中国 [07] C  
人工智能.中国 [07] CHINA.AI 人工智能.中国  
HINA.AI 人工智能.中国 [07] CHINA.AI 人工

[07] CHINA.AI 人工智能.中国 [07] CHINA.AI  
能.中国 [07] CHINA.AI 人工智能.中国 [07] C  
人工智能.中国 [07] CHINA.AI 人工智能.中国  
HINA.AI 人工智能.中国 [07] CHINA.AI 人工  
能.中国 [07] CHINA.AI 人工智能.中国 [07] C  
人工智能.中国 [07] CHINA.AI 人工智能.中国  
HINA.AI 人工智能.中国 [07] CHINA.AI 人工



SPECIAL "PARTY-BUILDING" EDITION OF THE XIMALAYA FM XIAOYA SMART SPEAKER, DEVELOPED IN PARTNERSHIP WITH THE CCP.

---

人工智能.中国 | Gabriele de Seta

---

From the second half of the 2010s, artificial intelligence has become a major hype across Chinese tech industries, venture capital investment and government policy. The BAT national champions (Baidu, Alibaba and Tencent) have invested heavily in AI research and development, opening research centers in China and abroad to attract global talent, while thousands of startups have benefited from AI hype to attract investment and reap the benefits of generous government funding. In a wave of innovation rhetoric closely resembling the previous hypes around Web 2.0 and Big Data, AI has become the most recurring buzzword in Chinese tech: besides its more predictable applications (industrial automation, self-driving cars, natural language processing and computer vision), almost everything in China—from e-commerce platforms to public utilities—is being revamped as an ostensibly “AI-powered” service. Drawing on research into the development of artificial intelligence technologies and products, this chapter charts China’s AI hype via its representation across government policy documents, industry advertisement, commercial products and popular culture. As trends and catchphrases travel between corporate boardrooms and policy think tanks to propaganda materials and music videos, the interplay between technical innovation and planned development reveals how AI is constructed, in real time, at the intersection of sociotechnical constraints and national imaginations.

## AI LOVE

In December 2017, Taiwanese–American pop singer Wang Leehom released his 16th album *A.I. Love*. Blending a mid-tempo EDM beat with autotuned vocals, the title track “A.I. Love” is a catchy play on the homophony between the AI acronym and the Chinese term for “love”—爱 *ai*. The track’s music video opens with a flyover shot of the fictional Daode Research Laboratory, where a scientist in a lab coat is activating a female android with an injection of a pink liquid.

The actor portraying the scientist is a guest of honor: Taiwanese–American venture capitalist and AI mogul Kai-Fu Lee, who in the following scene brings the now operational cyborg to Wang Leehom’s apartment. The singer and the android get married and get on with their awkward love life, which includes playing a game of *go*, watching movies, singing karaoke, reading books in bed, taking selfies and eventually zooming across a neon-lit Taipei in a sports car. Wang Leehom’s Mandarin lyrics explore the dichotomy between AI and *ai* (“Love, is just one word / but for thousands of generations, humans still don’t understand it / but A.I. can solve all our problems”) while also describing a stereotypically gendered artificial intelligence (“everyone wants a perfect lover / that gives a shoulder massage at any time”). Even when the contradiction is resolved (“artificial intelligence finally has perfected love / just don’t challenge



it at *go*”) and cyberian superiority is accepted (“no longer worry about the world’s problems / it will colonize Mars”), one question remains open: “but where do ethics go? Where do ethics go? Where?”

In its four-minute run time, “A.I. Love” encapsulates the major talking points of the hype around AI in China—computational solutionism, autonomous non-human cognition, and uncharted ethical implications. Besides the common sci-fi trope of the gendered AI, Wang Leehom’s song features a key element of Chinese AI history: *go*, an abstract strategy game invented in ancient China and notoriously more complex than chess for neural networks to master. In March 2016, the AlphaGo program developed by Google DeepMind beat Lee Seedol—the South Korean 18-time world champion—over five games of *go*. Echoing the historical chess defeat of Gary Kasparov at the algorithmic hands of DeepBlue in 1997, the AlphaGo vs. Lee match spurred the South Korean government to invest 1 trillion KRW in AI research; livestreams of the five games were speculated by more than 280 million Chinese viewers and made a deep impression on the country’s technological imaginary. As Kai-fu Lee himself writes, “Overnight, China plunged into an artificial intelligence fever. The buzz didn’t quite rival America’s reaction to Sputnik, but it lit a fire under the Chinese technology community that has been burning ever since” (2018). The importance of this quasi-Sputnik moment is confirmed by the reaction of Chinese authorities to the *go* match between AlphaGo and current world champion Ke Jie more than a year later in Wuzhen, China. Likely concerned by the implications a defeat of a Chinese *go* player by an American AI would have had on national pride (Ding 2018), government authorities forbade local websites and platforms to broadcast the match in any form, including “text commentary, photography, video streams, self-media accounts and so on” (Huang 2017). In spite of this ban—which was eventually lifted in September 2018—Chinese audiences managed to find creative ways to follow the match as it happened, either by circumventing censorship and accessing foreign platforms, or by replaying the game moves on their own *go* boards.

#### BEATING HEARTS AND THOUSAND-MILE EYES

Despite his Taiwanese family heritage and his American origins, Wang Leehom has successfully tapped into the global circulation of a transnational Chinese identity by becoming a major Mando-pop star, and this is why a track like “A.I. Love” appears, on a surface reading, to be an ecstatic paean to Chinese AI. Similar transnational connections behind the construction of national technological imaginaries are exemplarily embodied by Kai-Fu Lee. Born in Taipei in 1961, Lee emigrated to the US in 1973 and got his PhD at Carnegie Mellon fifteen years later, with a thesis on his development of the world’s first speaker-independent continuous speech recognition system. After working as a research scientist for Apple, Lee moved to Beijing in 1998, where he acted as the founding director of Microsoft Research Asia, a leading hub of global next-generation computing research; he then served as president of Google China before the company exited from the Chinese market in 2010. The author of inspirational books loved by Chinese readers and a widely followed celebrity on Chinese

天下文化 出版

# 人工智慧 來了



前Google工程師  
李開復  
王詠剛 著

social media, in 2009 Lee established Sinovation Ventures, an investment firm co-located in Beijing, Shanghai, Shenzhen, Seattle and Silicon Valley with a portfolio of more than 300 companies. Many of Lee's enterprises testify to his lifelong pursuit of innovation in artificial intelligence: Microsoft Research Asia's agenda includes the development of speech recognition, computer vision and AI; Sinovation Ventures invests heavily in machine learning and AI companies. Given his transnational background and eclectic career, it is somewhat surprising to read Lee's recent formulation of a threatening "AI race" between China and the US that would result in the supremacy of one "AI superpower" dominating the 21st century (Lee 2018).

It is undeniable that, via the bridging efforts of tech executives and investors like Kai-Fu Lee, China has become a world-leading center of AI research. According to Lee, in particular, Beijing's Zhongguancun district is today "the beating heart of China's AI movement" (2018): besides Microsoft Research Asia, the district hosts the Baidu Research lab (also co-located in Silicon Valley and Seattle) which in 2014 was the first institute set up by a Chinese tech company to explicitly focus on AI research and development, and leading AI chip design firm Cambricon. Sinovation Ventures itself, also based in Zhongguancun, established its own AI Institute in 2016. But besides this beating heart of Beijing, the geography of Chinese AI development revolves around the major urban centers where the other BAT companies are located. One after the other, the BAT companies have all opened their own AI research institutes: Tencent founded its AI Lab in 2016, co-located between Shenzhen and Seattle; one year later, Alibaba's Jack Ma inaugurated his DAMO academy, based in Beijing, Hangzhou, Singapore, Israel, San Mateo, Bellevue and Moscow. Other massive tech companies and startup unicorns also cluster around Chinese metropolitan areas: ByteDance, based in Beijing, relies on machine learning and AI to provide personalized content to users of its apps Toutiao and Douyin; Huawei, which has recently unveiled a full-stack AI portfolio and a mobile AI chip, has opened its Noah's Ark Labs in Shenzhen, Hong Kong, Dongguan, Shanghai and Xi'an; YITU Technology, based in Shanghai, is one of the global leaders in AI-powered machine vision. Other cities and provinces are following the lead of China's research hubs and channeling government funding into AI initiatives and innovation parks, building on locally available expertise and data labor (speech recognition in Hefei, optics in Wuhan, and so on). The spatial geography of AI also evidences center-periphery tensions and inequalities: for example, leading Hong Kong-based machine vision startup SenseTime has participated in a joint-venture deploying AI-powered surveillance technologies in Xinjiang province, partly realizing the government's vision of a "thousand-mile eyes" system overseeing ethnic and religious minorities in the area (Chang 2018).

#### DATA AS OIL, POLICY AS PIPELINE

The most widely used Chinese term for artificial intelligence is the direct translation *rengong zhineng* (人工智能), which encompasses a broad range of technologies including core AI technologies (such as machine learning and natural language processing) and AI-related products (such as smart speakers



TOP: Still from Xi Jinping's 2018 New Year speech.

BOTTOM: These two books about artificial intelligence appear on President Xi Jinping's bookshelf.

and recommendation systems). The hype around AI is clearly evidenced by the proliferation of *rengong zhineng* as a prefix added to commercial products and services—everything in China seems to have suddenly become AI-powered, from real estate investment to public toilet management. As briefly chronicled in the previous section, the Chinese AI industry saw rapid growth in the second half of the 2010s. It is widely argued that China’s distinct competitive advantage in the field results from four factors: its pre-existing Internet industry, a large pool of talent, a massive mobile internet market, and supportive government policies. The first three factors feed into one of the most pervasive images behind China’s AI boom: a competitive advantage on data collection, extraction and exploitation. If artificial intelligence is the new electricity—as Chinese-American computer scientist Andrew Ng provocatively puts it (Lynch 2017)—data is the oil necessary to generate it, and China is the “Saudi Arabia of Data” (Lee 2018). But massive reserves of (dubiously gathered and processed) user data are not enough to propel the Chinese AI industry to its much sought-after global lead: as in many other areas of technological innovation, the role of government policy is central. Since 2016, the Chinese government has proactively supported the development of a national AI industry through whitepapers, policy guidelines, implementation plans and “government guidance funds” (Feng 2018). These documents and stimuli directly influence global investors, Chinese companies and local governments, steering the development of the national AI industry.

When President Xi Jinping addressed the nation for his customary New Year speech in 2018, careful observers noted that his bookshelves displayed new additions to his collection, including two volumes on artificial intelligence: Pedro Domingo’s *The Master Algorithm* and Brett King’s *Augmented* (An 2018). Alongside political signaling and propaganda materials, policy documents related to AI are regularly touted in the international press as examples of the Chinese government’s enthusiastic endorsement of this technology and its aspiration to successfully lead the global AI race. But even a quick look at some of the major milestones in Chinese AI policy reveals how policymaking often oscillates between vague commitment and playing catch-up with emerging technologies with unclear future implications. In the “Outline of Medium and Long-term Plan for National Science and Technology Development (2006–2020),” the State Council identified information technologies as one of eight areas of advanced technologies to support—AI here is just one entry in a sub-list.

It was only with the “13th Five Year Plan for Developing National Strategic and Emerging Industries (2016–2020)” that the State Council explicitly identified AI as one of several emerging technologies of strategic interest and outlined five agencies tasked with AI policy development. More specific plans—mostly released during and after 2016, the “Sputnik year” for Chinese AI—connect AI development to existing policy frameworks such as the “Internet Plus” plan, the robotics industry or the recently abandoned “Made in China 2025” plan. The 2017 “Guideline on Developing Artificial Intelligence (New Generation of Artificial Intelligence Development Plan)” is perhaps the most widely quoted Chinese AI policy document, as it set the lofty goals of achieving noticeable



TOP: An augmented reality Tai Chi lesson at the *smart park* powered by Baidu's DuerOS in Haidian District, Beijing

BOTTOM: AI for endangered species protection, Intel x WWF advertisement, Beijing Capital International airport.

progress by 2020, establishing a competitive industry and comprehensive policy by 2025, and commanding a world-leading role as global innovation center by 2030. By outlining areas of industry growth, nudging technological development and channeling investment flows, policymaking shapes how Chinese AI is perceived around the world, cementing a narrative of grassroots enthusiasm and competitive advantage propelling China onto the global stage.

#### CHINA HAS DEVELOPED AN AI THAT...

Besides investor meetings, startup incubators and policy working groups, AI is increasingly present in Chinese everyday life—hidden behind app interfaces, touted by advertising and accessed as a service via public terminals or mobile devices. The most central AI product is cloud computing: BAT companies have integrated AI solutions in their cloud computing platforms (Alibaba Cloud and PAI, Baidu’s ABC–Stack, Baidu Cloud and Baidu Brain, Tencent’s Angel and AI cloud), and other companies like Huawei and iFLYTEK have developed both general AI development platforms and service-specific portfolios. Cloud computing allows third-party companies to offer AI-based services that can be accessed by networked consumer devices. Some of these services, such as AI-powered assistants, smart speakers and voice recognition, have already become integrated into everyday computing, with tech companies competing to occupy market niches like shopping assistants (Alibaba’s Ali Xiaomi and Dian Xiaomi), conversational interfaces (Baidu’s DuerOS, Huawei’s HiAssistant, Tencent’s Xiaowei, iFLYTEK’s VoiceTouch) and smart speakers (Baidu’s Raven H, Alibaba’s Tmall Genie X1, Tencent’s Ting Ting). Other services, including machine vision, logistics and autonomous driving, remain either confined to the domain of policing and surveillance (such as SenseTime’s various video analysis, feature tracking and identity verification products), under experimentation in factories and distribution centers (such as JD.com’s fully automated warehouses, Meituan’s dispatch system or Cainiao’s smart supply chain) or still in the stage of early development (such as Baidu’s Apollo, an open-source autonomous driving OS).

The public front of the Chinese AI industry is easily readable in advertising and tech demos. Artificial intelligence—often embodied by sleek cyborg figures similar to the android protagonist of the Wang Leehom video or by glowing, brain-shaped nodal networks—appears in the advertising of a large range of products, from “AI-capable” consumer electronics to “AI-powered” apps and services. Countless tech demos offered at industry conventions and tech fairs are circulated via short videos and online advertisement on social media platforms, but companies also compete for consumer attention by showcasing their AI products via installations in public spaces and flagship stores. The various examples of self-checkout stores opened across Chinese cities propagate the vision of an AI-powered “new retail” achieved by a combination of machine vision (for both face and product recognition), RFID and cashless mobile payments. Qiu Hao and Xin Xiaomeng, the two “AI news anchors” (the first male, the second female) unveiled by Xinhua News Agency between late 2018 and early 2019, are successful examples of the everyday marketization of AI: developed



AI ANCHORS QIU HAO AND XIN XIAOMENG: FROM NEW CHINA TV YOUTUBE CHANNEL.

by Xinhua in collaboration with Chinese search engine company Sogou, these AI news anchors are ultimately a speech synthesis software capable of reading news scripts combined with a realistic digital rendering of two actual Xinhua journalists, but they successfully embody China's AI aspirations for both national and international audiences. The AI hype doesn't seem limited to retail and media industries: the "AI Park" opened in Beijing's Haidian District in late 2018 is powered by the Baidu DuerOS and offers augmented reality Tai Chi lessons and unmanned shuttles while tracking its visitors with sensor-paved walkways and face recognition cameras. As AI is reduced to the visible implementation of surveillance technologies for consumer-friendly social control—epitomized by face recognition toilet paper dispensers and automated jaywalker-shaming roadside displays—everyday life becomes increasingly mediated by less visible forms of automation and computation.

### IT'S ABOUT ETHICS IN AI DEVELOPMENT

In the wake of Ke Jie's defeat by AlphaGo, China's Ministry of Science and Technology appointed companies like Baidu, Alibaba, Tencent and iFLYTEK as its "National Champions," encouraging them to apply their own expertise to the development of next generation AI products and services. Among these products, it is notable how some companies came up with their own *go* programs, bringing the gaming competition back to its home turf: Tencent's own Fine Art program defeated Ke Jie in January 2018, and Beijing Thinker Technologies' Golaxy program replicated the same feat in April 2018. But beyond the *go* craze, the Chinese AI industry has undeniably succeeded in branching out into different domains from healthcare to the military, challenging the US's technological leadership and unsettling preconceptions about Chinese innovation. As analysts warn against the massive loss of Chinese jobs potentially brought by automation, and market observers dispel myths about Chinese users not caring about personal privacy and data collection, the question of AI ethics emerges as the latest industry-wide hype. In May 2019, the Beijing Academy of Artificial Intelligence (BAAI) in collaboration with various universities and tech companies released the "Beijing AI Principles" (2019), a document detailing fifteen ethical guidelines for the development, use and governance of AI systems and products. This effort follows the first steps taken by multinational companies and international organizations in Europe and the US to lay down ethical standards for AI; at the same time, it allows China to plug its policy vision of a "human community with a shared future" via widely agreeable principles of sociotechnical *daode* (ethics). This conflation between an industry trend and a governmental keyword exemplifies the convenient alignment of different temporalities: in the Beijing AI Principles, a foreign policy concept proposed by former Chinese president Hu Jintao and championed by current president Xi Jinping (the "community of common destiny") underpins the recommendations for an ethical development of artificial intelligence technologies. After all, Wang Leehom's music video opens with a scene inside the Daode Research Laboratory, and its refrain "Where do ethics go?" finds in these efforts a tentative answer.

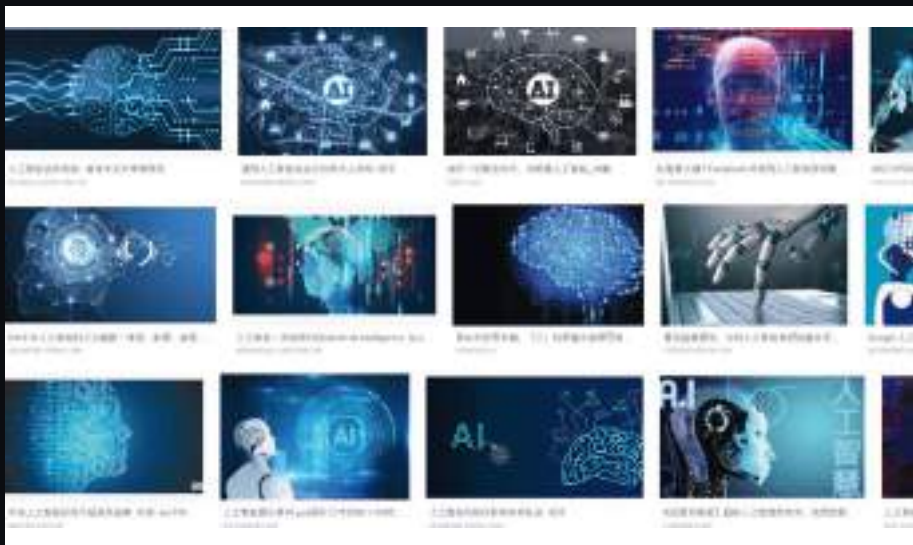

IMAGE SEARCH RESULTS FOR 人工智能 (ARTIFICIAL INTELLIGENCE) ON BAIDU (TOP), AND GOOGLE (MIDDLE AND BOTTOM), JULY 3, 2019.

## REFERENCES

- An, B. 2018. "Xi's bookshelf illustrates goal of developing AI powerhouse." Retrieved August 12, 2019, from Chinadaily.com.cn website.
- Beijing Academy of Artificial Intelligence. 2019. "Beijing AI Principles." Retrieved August 12, 2019, from Beijing Academy of Artificial Intelligence website.
- Chang, A. 2018. "Zhongyang Zhengfawei mishuzhang: Quebao 2020 shixian gonggong jiankong quanyu fugai" [Secretary General of the Committee of Political and Legal Affairs: Ensure comprehensive public surveillance coverage by 2020]. Retrieved July 1, 2019, from Sina News website.
- Ding, J. 2018. *Deciphering China's AI Dream: The Context, Components, Capabilities, and Consequences of China's Strategy to Lead the World in AI*, 1–44. Oxford: Future of Humanity Institute, University of Oxford.
- Feng, E. 2018. "China's State-owned Venture Capital Funds Battle to Make an Impact." Retrieved July 1, 2019, from *Financial Times* website.
- Huang, Z. 2017. "An epic man–against–machine tournament is taking place in China but Chinese viewers can't watch it live." Retrieved July 1, 2019, from Quartz website.
- Lee, K. 2018. *AI Superpowers: China, Silicon Valley, and the New World Order*. New York: Houghton Mifflin Harcourt.
- Lynch, S. 2017. "Andrew Ng: Why AI is the new electricity." Retrieved December 26, 2018, from The Dish website.



ARMATURES OF A NEW AUTONOMOUS URBANISM [08] 自行城市规划的新架构

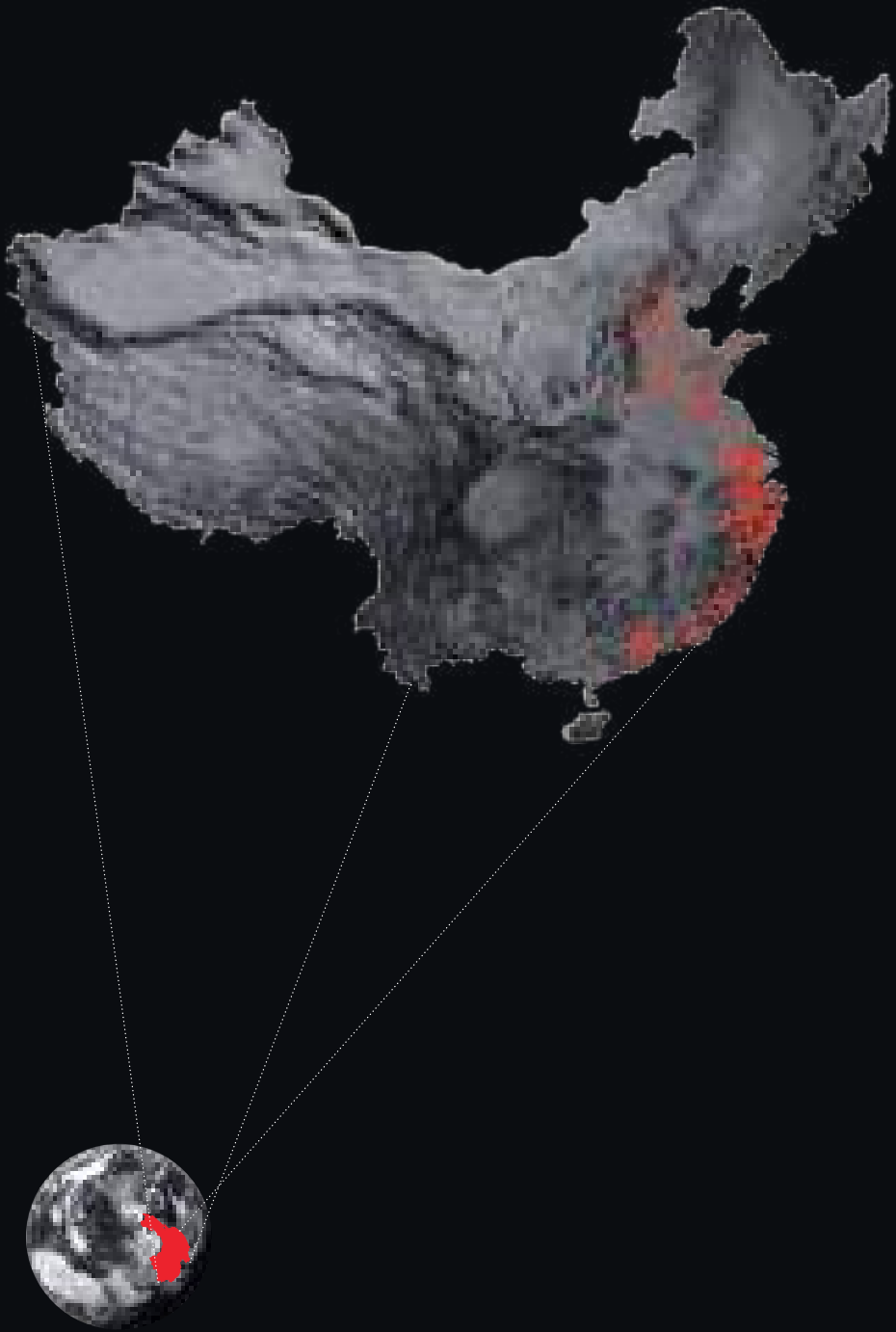

TAOBAO VILLAGES, CHINA, 2019

# THE ARMATURES OF A NEW AUTONOMOUS URBANISM

---

自行城市规划的新架构 | Jason Hilgefort & David Li

---

The recent emergence of Dispersed Infrastructures frames a moment in time when we can fundamentally reconceive of how we make, fund, and even conceptualize the form of the world around us. The technologies of moving parts which defined the 20th century city—i.e., cars and elevators—reshaped our now Constellated Cities. What then are the spatial implications of these emergent, non-city hubs for digital transactions, photovoltaics, drones, etc? If we as a society no longer require centralized systems and their subsequent governments, what is the role of the spatial practitioner in this emerging reality?

## AN AUTONOMOUS URBANISM

Cities began as a simple collection of individuals sharing common elements to each other's benefit. Over time they have slowly evolved to include mega-regional, multimodal, geographically carpeting spaces facilitated by vast infrastructural, capital, and political networks manifested by large, far-reaching governmental and corporate built forms. With the emergence of dispersed infrastructural realities, we stand at a disruptive moment—where the assumed reliance of human habitat on top-down governmental systems and intensely urbanized forms of development is very much in question.

The collective innovations of elements such as mobile phones, self-driving technologies, photovoltaic cells, drones, block chain and AI points toward a myriad of possible shared autonomies. Existing development of a *community* requires assorted pipes, wires, banks and other environmental insertions. But now we can easily obtain energy from the sky, exchange value digitally, move without roads, and much more. These technologies allow for a totally new, and simultaneously retrograde, form of civilization formation. A new form of interdependent individuality is possible.

The smart city perspective sees all these societal tools and continues to assume that a top-down system should be employed by larger powers to the benefit of all. Dispersed infrastructures allow for a total recalibration of the collective. Now that our infrastructures can *talk to each other*, an overriding framework

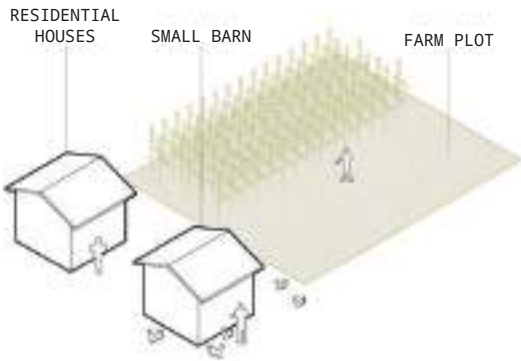

BEFORE  
2006

SMALL BARN BEING TRANSFORMED INTO  
PRODUCT PRODUCTION AND STORAGE AREA

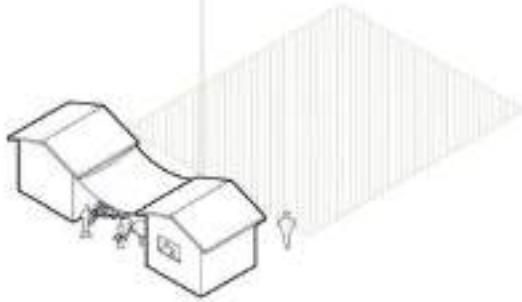

2014

BUSINESS EXPANDED.  
NEW WAREHOUSE OR PRODUCTION FACTORY

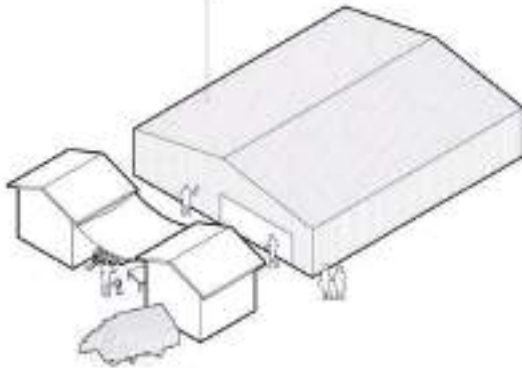

2016

is no longer necessary. These tools for an autonomous urbanism can be self-funded, self-managed, and yet all work together. The scale of such imbricated infrastructures allows for stepped funding, evolving phasing and more self-sufficient modes of *urban* development.

#### OPEN SOURCE VILLAGES

Our current reality of interconnected global capitalism has left the rural lands beyond in pursuit of more urban conceptions. Whether the vacancies of Italy, left-behind villagers in China or the ignored realities of small-town America, the challenges facing the rural have yet to be resolved. But there are indications about models for alternative futures for our rural habitats.

Taobao villages in China point to a future where rural making and craft skills pivot to link to global supply chains and permit the labor realities of the rural to demand the potentials of the urban. Looking at older formal examples such as *Citta Diffusa* outside of Venice, one can see the potential of a constellation of urbanisms linked to global supply chains. Extending upward from Venice and arching to the UK, the so-called *Blue Banana* is a series of smaller cities linked by transport and economic exchanges across Europe (Brunet 1989). Similar urban forms have existed historically in India—Calcutta to Delhi—and are often described with the term *Desakota*, first coined in regard to urban/rural forms seen in Indonesia (McGee 1991).

These forms of Constellation Cities point towards a possible new future for our scattered countryside habitats. The necessity in these places for greater logistical, ecological and economical connections to our new global reality can be seen in Dispersed Infrastructures and the potential resulting Autonomous Urbanisms.

#### DISPERSED INFRASTRUCTURES

The inventors and industries that designed and released cars and elevators upon our cities last century could not have foreseen the implications of their innovations on our environment and society. The technology companies now developing new forms of markets, movement, waste, and water and energy collection are similarly blind to the extrapolations of their works. However, test sites across the globe form a series of experimentations and case studies where one can document the realities on the ground. These spatial realities can be used to extrapolate lessons for our emergent environments.

The implications of new markets and financial exchanges can be observed in the so-called Taobao villages of China and the mobile banking hubs for M-Pesa in Kenya. The most iconic storage nodes for self-driving vehicles are in Germany, while the first drone port is currently underway in Kigali, Rwanda. The future of water-based microports is perhaps in the ancient but ever-evolving floating fishing villages of Ningde, China. The supply of fresh water from the air is being explored by companies like Watergen in communities in Israel and Morocco. Meanwhile, waterless small-scale toilet technologies are being implemented

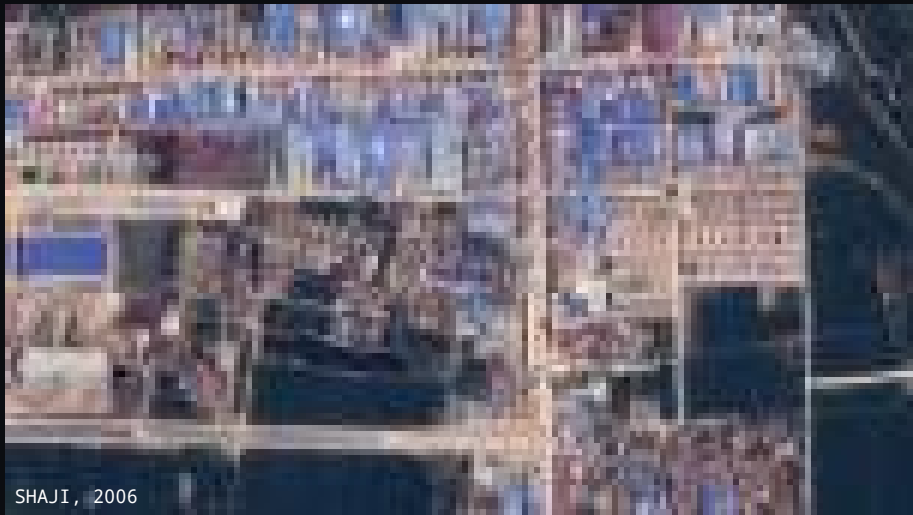

SHAJI, 2006

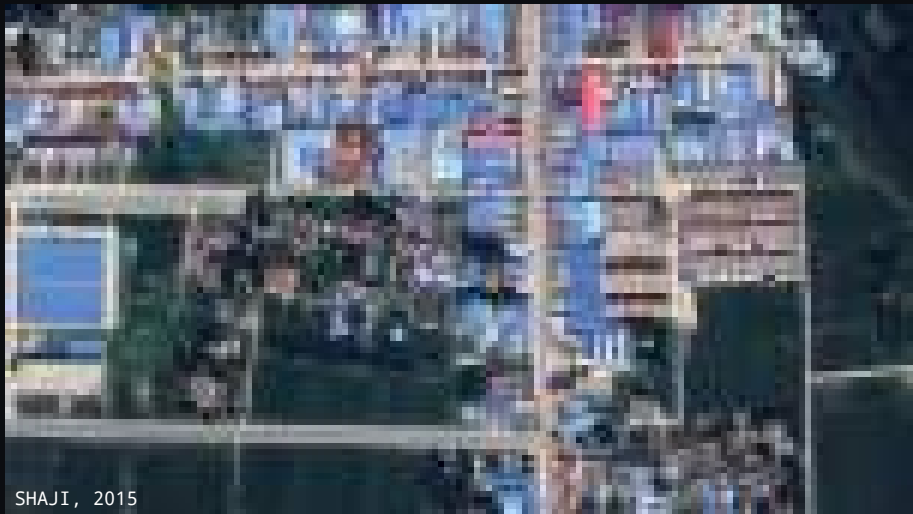

SHAJI, 2015



SHAJI, 2018

in Madagascar. New microgrid systems that mix storage, photovoltaics and small-scale wind energy generation are being tested in the dispersed island communities of the Philippines.

#### AN E-MERGING EXAMPLE

In China, digitalization brought by the Internet is one of the key drivers of economic reform. While the tremendous growth of e-commerce through Alibaba and Taobao, and the widespread use of WeChat payment, has grabbed global attention, the foundational dynamism driving such growth remains invisible. The tremendous growth of e-commerce in China would not have been possible without the dynamism of villagers to leverage the tools and technologies of digitalization for economic development and prosperity.

Shaji village (沙集镇 *shajizhen*), a small township of 50,000 in the north Jiangsu Province next to the city of Xuzhou, came into focus for Alibaba Research as it analyzed the e-commerce market in China using big data visualization in 2010. Shaji sparkled on the map as a bright dot of e-commerce activity in middle-of-nowhere rural China. The staff of Alibaba Research were puzzled, and their first reaction was to check the accuracy of the source data. The data was accurate, and the team booked the earliest possible flights to travel to this village.

As they arrived in this rural farming village in north Jiangsu, they met people young and old working in front of old computers in their e-commerce shops. These people processed orders and handled customer service from their humble houses. In the backyard of their farmhouses, people worked in makeshift factories producing flat pack furniture, packaging it to be shipped all over China. In the early evening, the villagers carried these packaged goods made in their backyard factories on DIY rickshaws produced from motorcycles, to the town's logistic center, where they awaited pick up for distribution across China.

#### THE ORIGIN STORY

The origin story of Shaji has a humble beginning. Sun Han, a Shaji native, left the village for school and worked in a coastal area, like most rural youth, in early 2000. Sun returned to Shaji on his parents' request to prepare for marriage in around 2005. While going through rounds of matchmaking, he opened up a small Taobao shop to resell mobile phone accessories sourced from friends he had made in Guangzhou. Once married, Sun took his new bride for a honeymoon in Shanghai where he discovered Ikea and the flat pack furniture that was becoming popular amongst the emerging middle class of China. He acquired a few simple Ikea pieces and brought them back to Shaji for study with two other friends. Working with local carpenters, they made their first version of hacked furniture, photographed it and put it on their Taobao shop. They sold a few in the first week and demand continued to increase. Business was booming. Very soon, they were fixing up their houses and buying new cars and the whole village was curious about how they had made their money. As the business expanded, they recruited villagers to join their operation, and the knowledge of e-commerce and the business of flat pack furniture spread. Their employees and relatives



started to open up their own e-commerce shops. With the low barrier of entry to e-commerce and the simple form of the furniture, the village flourished with rapid multiplication of shops and factories making flat pack furniture to be distributed all across China.

#### A NEW MODEL

Inspired by what they saw in Shaji, Alibaba Research worked with the Chinese Academy of Social Science (CASS) on a “Shaji model” that summarized the critical drivers of their success (CASS 2011).

1. *Bottom-up model*: unlike typical attempts at bringing e-commerce to rural areas via top-down decisions, e-commerce had been started from the bottom up by the rural residents themselves.

2. *Copy to scale*: the low barrier of entry enabled others to copy the existing business and start their own. The paper called this cell division copying with exponential growth.

3. *E-commerce markets drive industrialization*: unlike the traditional model of industrialization, by offering a considerable amount of cheap labor for the manufacturing of goods for others, the industrialization was driven by the market reality in deciding what kind of tools, equipment and technologies to adopt.

4. *A clear core group who compete and collaborate*: the core group of Shaji e-commerce were new entrepreneurs who were mostly related to each other through family ties. The multiple layers of relationships created a system of competition and collaboration that further expanded the complexity of the business ecosystem and contributed to the growth of diversification and specialization.

5. *“Presence and not interfering” governance*: the government did not try to lead the development policy or direction, and instead focused on building infrastructure such as roads, electricity and telecommunication. Also, the government was responsible for solving problems that arose from the community, such as securing land usage for the factories (changing farmland to industrial land is extremely difficult in rural China).

6. *Proper vertical markets*: the furniture market, with its vast segmentation, enabled the cell division model of scaling to specialize across different segments. Thus, a proper vertical market facilitated the cell division model of scaling in the Shaji model.

#### THE MASS FLOURISHING OF TAOBAO VILLAGES

The researchers also came up with a definition of *Taobao village* to study the phenomenon of e-commerce driven industrialization and the modernization of rural areas. The *Taobao village* is defined as an administrative area where more than 10% of the population is involved in e-commerce activities, including sales,

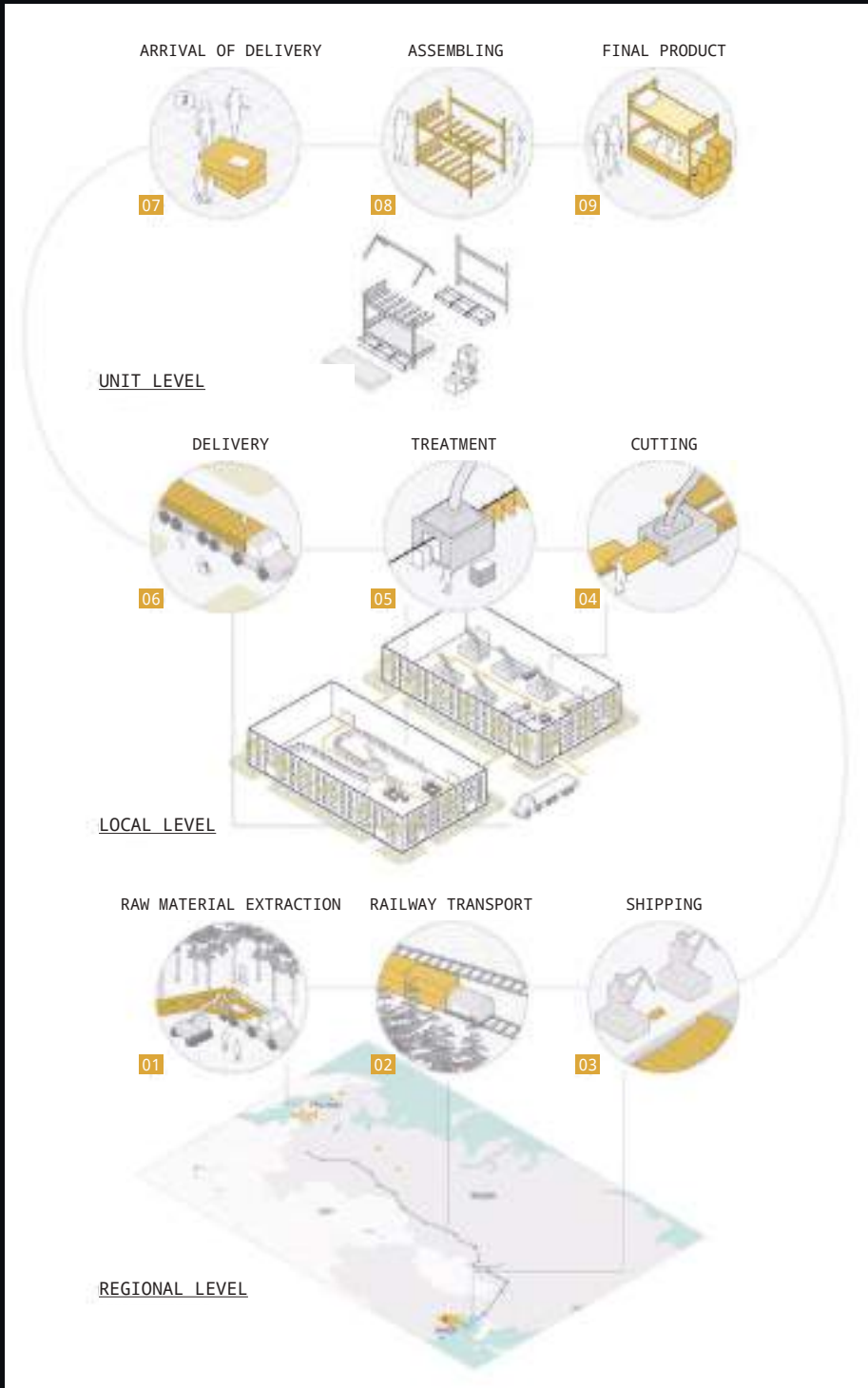

customer services, production of goods and logistics that generates more than 10 million RMB annually in e-commerce sales. When the team discovered Shaji in 2010, 37 similar villages were also discovered. As of 2018, there are 2,500 Taobao villages across China which generate hundreds of billions of RMB in revenue. Shaji village itself has grown from one e-commerce shop in 2007 to over 6,000 in 2018 that generate over 10 billion RMB.

While it's easy to read the story of Taobao villages as a poverty alleviation measure, it is, in fact, a "disruptive innovation" (Christensen 2015). The combination of Internet/e-commerce and the use of digital fabrication lowered the cost of the flat pack furniture versus the mass production and warehousing of Ikea, and made them affordable and accessible to the emerging middle class in China. The open collaboration and sharing of the system further brought down the risk and cost of new product development.

Technologies do not bring about change, they are merely tools to facilitate change in the hands of the right people. The innovative people of Shaji and the other Taobao villages quickly adopted new tools to capture opportunities. While the number of Taobao villages has grown tremendously over the past decade, there are also a large number of failed attempts. Technology transfer can bring in some initial economic growth, but it was indigenous innovations, enabled by high dynamism, that led to real sustainable long-term growth.

#### AFORMAL ARMATURES

Cities have traditionally been the centers of civilization and knowledge, but we are now at a time where one must ask yet again—what is a city? Where does a *city* stop? Cities have always been defined not merely by planners, architects, developers and governments, but often by their moving parts. Le Corbusier famously said that historic cities were made of "curved streets that are a donkey's track" and that the industrial age would allow for "long straight streets for men." If we no longer need roads, power grids, and market halls, and knowledge now flows through the air—what space remains for society? How do we create armatures within the possibilities of this new Autonomous Urbanism?

#### REFERENCES

- Brunet, Roger, and Jean-Claude Boyer. 1989. *Les Villes "européennes": rapport pour la DATAR, Délégation à l'aménagement du territoire et à l'action régionale*. Paris: Documentation française.
- CASS, and Ali Research. 2011. "沙集模式"调研报告." Beijing, China: China Academy of Social Sciences.
- Christensen, Clayton M. 2015. *The Innovator's Dilemma: When New Technologies Cause Great Firms to Fail*. Reprint. Cambridge, Mass: Harvard Business Review Press.
- McGee, T. G. 1991. "The Emergence of Desakota Regions in Asia: Expanding A Hypothesis." In *The Extended Metropolis: Settlement Transition in Asia*, 3–25. Hawaii: University of Hawaii Press.







TOP: "Time is Money, Efficiency is Life" (Chinese: "时间就是金钱, 效率就是生命") is a widespread slogan of China's economic reform. It was initially a quote from Yuan Geng made in 1981.

BOTTOM: Picture taken by the author in a factory ruin during the "2014 Bi-City Shenzhen-Hong Kong Biennale of Urbanism/Architecture: Value Factory."

# SPEED POLITICS OF DANMU

弹幕的速度政治 | Dino Ge Zhang

时间就是金钱，效率就是生命

Time is Money, Efficiency is Life.

Shenzhen speed is the epitome of what Paul Virilio calls “*dromological progress*.”<sup>1</sup> Since the 19th century, the West has long relied on dromological progress to dominate, first through a period of naval superiority during the Opium Wars then a second period of technological growth after the Second World War. For China, Shenzhen was the first dromological experiment of the Reform era after the traumatising stagnation of the Cultural Revolution.

The term “*Shenzhen speed*” was first coined to describe the speed of construction on the famous Guomao Building—“*three floors in a day*.” However, the Shenzhen of Deng Xiaoping is by no means a delayed replication of Mao’s “*catching up with the West*” but a mutated compound of both the technological vitalism of large factories, start-ups and *shanzhai* incubators, and the natural vitalism of a huge reserve army of migrant labor from the inland provinces. Academics, artists and journalists alike became entrenched in investigating labor exploitation, *shanzhai* workshops, unconditional acceleration of production and even the aesthetic rendition of outmoded and gentrified factory ruins. Mary O’Donnell (2013) reflects on Shenzhen speed through an uncanny association between speed’s pharmaceutical (speed is the street name for amphetamine) and economic metaphors: “to the extent that profit under global capitalism is a function of time, we are all on speed.” Speedy economic development brings efficiency, prosperity, consumerism and therefore happiness; amphetamine brings an adrenaline rush, mental concentration, efficiency and therefore happiness. The dromological obsession applies to both pathological and pragmatic temporality: acceleration is both an addiction and necessity for the Shenzhen model.

The missing link in explicating Shenzhen speed is crowd/traffic management which has always occupied a crucial place in China’s politics of speed. The 300,000-strong army of workers at Foxconn during its heyday remains an incomprehensible scale to even the fiercest critique of manufacturing capitalism (thus it remains a fascination). It is also a constant administrative horror for the authorities (thus the absolute necessity of supervision by a military barracks

1 From the Greek *gromos* (to race). In *Speed and Politics* (2006), Virilio proposes the term “*dromological progress*” to consider how speed has become the main driving force for new societies built around the need for technological advances to face a constant state of war.



massive wholesale of sanitary pads, please contact 5564878

assassin for hire, contact 84523

COFFIN SALE, CONTACT 484854

Fake ID, contact 7823121

Painless Abortion, contact 1222334

change your fate, contact 741165

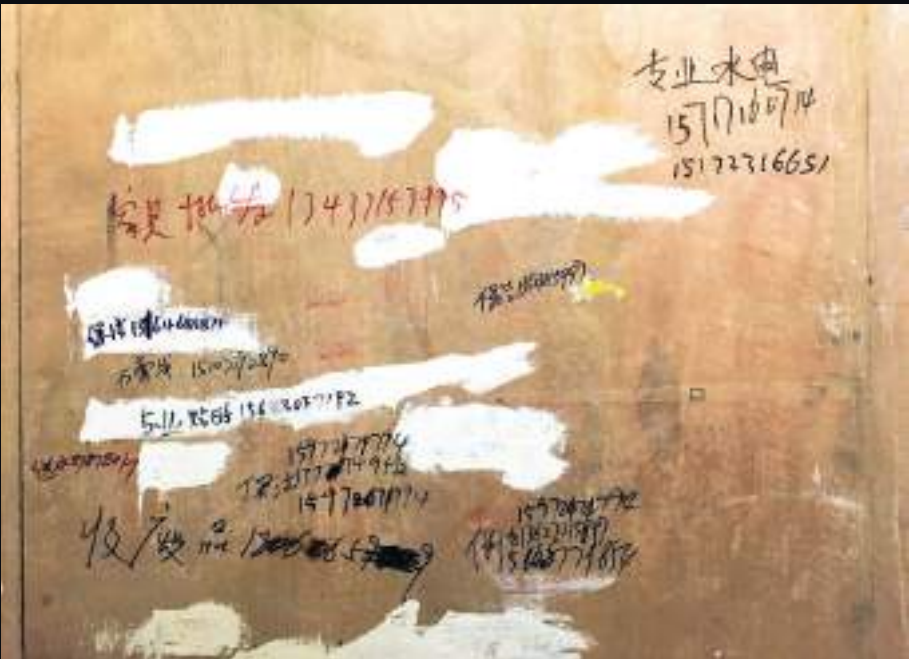

A TRANSLATION AND A LESS DENSE SIMULATION OF LOVE DEBT'S DANMU COMMENTS.

stationed nearby). The traffic of swelling crowds is used to symbolize how the Communists took power. Gradually, it became an agoraphobic image of disorder. Shenzhen speed relied upon the crowd and *liuliang* (流量, traffic), which refers to both the dense traffic of vehicles/people (the yardstick of urbanization) and Internet traffic (the basic measurement of platform capitalism). However, the marching crowds must be contained and dispersed—unapproved loitering and gathering on a square (regardless of purpose) is thus stigmatized as low *suzhi* (quality) behavior.

The Chinese obsession with *danmaku* or *danmu*<sup>2</sup> is both a literal demonstration of the dromological obsession and a digital remediation of agoraphobia. A digital interface simulating traffic and crowd, *danmu* is a “comments-over-the-video” (Li 2017) system that has profoundly influenced China’s video cultures over the past decade by enforcing a specific politics of speed and real-time. According to the Wikipedia entry (2017) on Bilibili.com,<sup>3</sup> it is “a real-time commentary subtitle system that displays user comments as streams of moving subtitles overlaid on the video playback screen.” Popularized in Japan on video platforms like Niconico Douga, it has been largely appropriated by China’s video portal sites and even in cinemas.<sup>4</sup> The term itself literally means “bullet curtain” and was originally used to describe a video game genre in which the player controls an aircraft maneuvering through barrages of massed artillery fire (e.g., *Raiden*). In more technical terms, it is a comment system that utilizes a video stream overlay to display textual comments, which can come in a variety of pixels, shapes, colors, fonts and sizes—also known as “advanced subtitles”.<sup>5</sup>

## THE MARCHING CROWD

*Danmu* should not be understood solely as comments. To treat it as an intelligible conversation or a “linguistic network” would be a mistake as its ingenuity stands not in the textual, but as an interface of performativity for speed and density. In order to understand this performativity, I will start by revisiting the roots of Chinese *danmu* videos on once popular video site Acfun.

MC Shitou’s now enshrined video *Love Debt* on Acfun is an archaeological ruin of early *danmu* carnivals, and perhaps the best demonstration of a subcultural principle that could be summed up as: “*danmu* is the actual main body (as opposed to the video itself).” The core aesthetics of MC Shitou’s video was its “vintage” aesthetic—rather than the inherent quality of his music. Despite being regularly deleted by Acfun’s administrators, the comments gradually accumulated over time—therefore becoming “vintage.” Users repeated the

2 *Danmaku* in Japanese or *danmu* in Chinese refer to the same Chinese/kanji characters (弹幕) that are pronounced differently. This essay concerns mostly the Chinese context.

3 Bilibili.com is one of the leading *danmu* video platforms in China.

4 *Danmu* was implemented in Beijing cinema, where audiences could send comments via their smartphones during the movie to entertain each other (Liao 2014).

5 Different video platforms use different protocols: Bilibili uses ECMAScript (JavaScript based) and other unspecified digital infrastructures; livestreaming platform Douyu uses Flash sockets as it has three separate servers—*danmu* servers, *danmu* verification servers, and RTMP (Real-Time Messaging Protocol) servers.



same rituals by posting the same comments on the same video to prevent them from being wiped — the act of spamming comments to bump it to the frontpage is referred as *wafen* (literally “grave digging”).

Appropriating the aesthetic of the rural and the grotesque, MC Shitou fans utilised the comments to simulate the fly-posting of illegal advertisements (often referred to as *liupixian* or psoriasis) that are omnipresent on the poles, doors and stairs in suburban and rural China. Most of the time, these words were not posted for their literal meaning but as a visual effect via its simulation of the illegal posting of handbills and graffiti—not as static texts but as *moving traffic*. If traditional comments below the online video (such as YouTube) are the “habitation” of the masses, *danmu* simulates the flow of traffic—the marching crowd. Both density and speed are crucial measurements of how iconic a video is. There must be a large quantity of comments and they must flow.

The traffic must be controlled in order to flow. First, you must impose a speed limit. Instructions sent to the browser control the speed and other properties of each comment as it is “shot through” the video from right to left. By default, shorter comments move slower and longer comments move faster. The tweaking of options and properties are an explicit metaphor for vehicular mobility: on Bilibili, viewers need to pay premium virtual currencies just to apply for the “privilege” of posting comments in different colors, fonts or movement speeds; even a basic line of white text requires verified membership.

Second, the video platform must set, educate and enforce the traffic rules. The proper operation of *danmu* as a comment culture necessitates a knowledge of what the comments are supposed to perform in specific contexts—a netiquette. For instance, Youku (founded in 2006) was one of the earliest video portals in China, originally modelled after YouTube as a generic public archive of video content. Since 2012, Youku also adopted the interface of *danmu*, introducing the interface to the mainstream audience beyond its subcultural origin. In the context of both Video-on-Demand (VoD) video platforms (e.g., Bilibili) and live-streaming video platforms (e.g., Douyu), *danmu* gradually became synonymous with the word “comment” or *pinglun*.

However, veteran participants in this subcultural scene—active on early platforms like Acfun and Bilibili—often lamented its introduction to mainstream video portals like Youku. For them, the “quality” of comments was declining drastically as the new participants no longer understood the netiquette of the pioneers. As an anonymous informant—and avid user of Acfun since 2006—said in an interview (2016):

“*Danmu* are not simply comments. As a collective performance, it requires sufficient knowledge of the memes, back stories, and video aesthetics purported by [remix] videos [that originated on Acfun].”



VIDEO OF A PIRATE STREAM OF JAPANESE DRAMA *PLEASE LOVE ME*.

In these sort of streams, viewers collectively commentate on and express admiration to the protagonists, the most mainstream social function of *danmu*.

Mainstream video portals such as Youku were able to copy the interface format but not the participatory ethics, which depend solely on the core user groups who understand and preach the netiquette. Youku does not educate its users, who are often not dedicated enough to learn and participate in the technical and sociocultural knowledge—a specific netiquette—that proliferated on Acfun and Bilibili.

#### AESTHETICIZATION OF COMMENT CULTURE

In the language of interface, common perception assumes the discreteness of digital objects as they take shape on the screen. In other words, the video window and the comment window/section are separate spaces. According to video theorist Andreas Treske (2013), this arrangement reflects our historical understanding and usage of the video as a one-way broadcast. The interactivity of the comment system is therefore an “added layer.”

Alexander R. Galloway (2006; 2012) uses the game *World of Warcraft* as an example to discuss the separation between diegetic (the “immersive” 3D virtual world) and non-diegetic spaces (the user interface such as the skill bar, inventory, and so forth). If we suppose the video as the center stage or the diegetic space (the coherent narrative), comments are—from the perspective of the viewer—a feedback (the fragmented, inconsistent, instant responses) and therefore the non-diegetic space. The entry of messages into the frame totally obscures the distinction. By layering video and comments, *danmu* rejects the transparency of the conventional interface with its discrete and immutable objects. As An Tairan (2016) writes:

“At any given time, the scene may be overlaid with multiple ‘bullets,’ or comments, scrolling across the screen. The line between the content of the exhibitionists and comments of spectators is ultimately blurred. The viewer and the actor, the articulable and the visible, the word and the image, the subject and the object, literally become one (53).”

*Danmu* aims at becoming an integral part of the video, contesting it and possibly reversing the relation between the video and comment as the center and edge. It does not merely facilitate socialization of the online video but enforces an *aestheticization of comment culture*. Commentators are actors and performers in the most literal sense—“in” the video. Comments are not adjuncts, but the essential constituents of the video, its “actual main body” according to the subcultural principle. They are therefore not simply textual, they can be graphical, animated and even moving pixelated images (composed or coded as texts)—they convey a unique sense of aesthetic while being social.

#### REALTIMENESS: FROM VOD TO LIVESTREAMING VIDEO

As an interface, *danmu* manifests the politics of real-time on different video platforms. The regime of real-time or real-timeness is not an endless optimization toward immediacy but depends on the sociotechnological specificity of the platform. Real-timeness stands “at the intersection of real-time processing



SCREENSHOT CAPTURED ON DOUYU CELEBRITY CHUANGGE'S (串哥) CHANNEL DURING WHICH HE ASKED HIS VIEWERS TO PRESS 1 TO TOAST WITH HIM. "1111", "6666", "23333" and "hhhhh" are all ways to express a similar meaning to "LOL" or "LMAO".

and experience” (Weltevrede et al. 2014, 129). The operativity of real–timeness needs to be understood within each specific infrastructure. For instance, the social and aesthetic experience of real–timeness is very different in VoD and livestreaming video.

In the case of VoD, the social interface of *danmu* helps construct a sense of “virtual liveness” (Li 2017)—virtual because while the video is not live, the comments appear in real–time and in relation to each other. On the VoD platform Bilibili, the interface enables “a sense of live communication” or “pseudo–simultaneity”—having an argument with someone on *danmu* is “like quarrelling with a ghost” (Li 2017, 249). The two “quarrelling” comments are sent from different times (hours, days or weeks apart) but they occupy adjacent temporality within the timeline of the video. From the perspective of the third viewer, they are arguing in “real–time”—an illusion created by the synchronization of comments with the online video. In this case, commentators collectively contribute to the performance of video commentary and make the video feel “alive.”

In the case of livestreaming video, the interface of *danmu* has different implications. For instance, the livestreaming platform Douyu’s interface displays comments at the top of the video. However, the chat messages will “flow” across the screen in full–screen mode, instead of having a separate column. Given the limited screen space of mobile devices, the interface of *danmu* affords both a full screen video and a whole view of the comments. In the case of VoD, *danmu* comments are carefully composed and aligned, both individually and collectively. A strong netiquette turns these online acts into a very elaborate socio–aesthetic interaction, a sometimes almost artistic performance on the video surface. In the case of livestreams, however, full liveness in a way helps *vandalize* this coherent sense of aesthetics. For some of the *danmu* early adopters, full liveness can be undesirable as it banalizes and vulgarizes the flashy displays of *danmu* comments. Previously, comments were accumulated according to a collectively understood netiquette specific to the video platform and celebrated videos. Live reactions to livestreams no longer possess these qualities. The accessibility and popularity of livestreaming video has gradually taken over the technical elitism bestowed by the frequent (re)visitors and “worshippers” of the “enshrined” videos, such as MC mentioned earlier.

#### AGORAPHOBIA: CROWD AND SQUARE

As livestreamer Xima said in my interview with him (2016), “*danmu* on livestreaming platforms are for the “masses” (群众 *qunzhong*) who are mindless mobs or crowds.” This metaphor of crowds become crucial in understanding the effect of *danmu* on livestreaming platforms like Douyu. Apart from their immediacy, livestreaming platforms also accentuate the live performance through the contagious elation of temporal and virtual co–presence (viewers in the chatroom and the broadcaster in the livestreaming video). As Yves Citton (2017) writes, “the joint attention characteristics of live performances brings about “CROWD” EFFECTS, as it encourages unpredictable contagions of mood that spread directly from a spectator to his neighbors (102, emphasis in original).” The thrill



The image is a screenshot of a Twitch stream. The central focus is a saxophone player, known as 'Epic Sax Guy', performing a piece of music. The player is wearing a white shirt and is captured in a dynamic pose, blowing into the saxophone. The background is dark, and the lighting is focused on the player. Overlaid on the video is a large, dense chat window with numerous messages in various colors (white, yellow, red, blue). The chat messages are a mix of English and Chinese text, including phrases like '600', '10个小时的瓜生', '我选曹芳', and '曹孟德'. The chat is positioned in the foreground, partially obscuring the video. The overall scene depicts a popular live-streaming event where a specific piece of music has become a viral phenomenon.

SCREENSHOT TAKEN OF A TEN-HOUR VIDEO OF "EPIC SAX GUY" ON REPEAT, WHICH OVER TIME HAS BECOME A VIRTUAL "SHRINE" FOR VIEWERS TO REVISIT AND POST PRAYERS AND JOKES ON, AMONG OTHER RITUALS.

of participating in a popular channel is comparable to that of the “joyful elation of the Mexican wave” (Ibid, 102). In Christina Xu’s words (2019), it is “a viscerally social experience, like an opening night crowd at a movie theatre that you can summon any time.” Contrary to VoD, to summon crowds on livestreaming platforms, one has to be there on time. There is a qualitative difference between Li’s (2017) “virtual liveness” and the full liveness of being there in the shared spatio-temporality of the livestreaming channel.

On a popular channel on Douyu, comments flow fast across the screen in enormous quantity. It is thus impossible to keep up with every message. The alternative way to spectate, as viewers are already accustomed to, is to “zoom out” (or even “space out” at times) and view the “bullet screen” as a *whole*, instead of attentively reading individual comments. If the livestreaming channel is occupied by thousands of viewers, it is impossible to comprehend all the messages at a glance. It is easy to see this as an information overload that even defeats the original purpose or ideal of the “social” or dialogic experience of online chat rooms. Alternatively, we can focus on its aesthetic quality: *danmu* simulates the density of crowds. This imagery of crowds is quite consistent with how viewers on Douyu refer to each other as *shuiyou* or “water friends,” which comes from the meaning of ephemeral and anonymous fellowship between viewers in the literal flow.

Zooming out, instead of focusing on reading individual comments, we can observe crowds coalescing and dispersing in real-time. The sheer amount of comments overwhelms and relegates the online video in the background. Paul Virilio (1977) is particularly wary of the “inorganic mass” of the proletarian horde — the mob. He writes:

“It [the mob] means giving rhythm to the mobile mass’s trajectory through vulgar stimulation, a polemical symphony, transmitted far and wide, from one to the other, polyphonic and multicolored like the road signals and traffic directions... Reading implies time for reflection, a slowing down that destroy the mass’s *dynamic efficiency* (30–31).”

From the perspective of Chinese censors, *danmu* represents, or perhaps literally embodies, the uncontrolled and unfiltered masses. Livestreaming especially is the perfect embodiment of this “dynamic efficiency.” The circulation of the messaging masses must be curtailed just as protesting crowds must be under “traffic control.” Coincidentally, Virilio himself quotes Japan—the birthplace of *danmaku*—as an example of “habitable circulation.” The kinetic nature of protesting crowds pushed for the ban on loitering and the ban on gathering in Japan during the height of revolutionary fervor in the late 60s and 70s. China has implemented similar bans in the reform era since the 90s. Dai Jinhua’s essay (1999) on the shifting meanings of square or “plaza” also confirms the simultaneous desire and fear of this “dynamic efficiency” in post-Reform China. As Dai explains, the square or plaza was never a neutral term as it used to symbolize “the people, a colossus collective that ablates away class and individual



differences” but gradually it became synonymous with malls and high rises. Naming high rises and malls “plazas” is a nomenclature imported from the closest “Asian dragons” (Hong Kong and Taiwan). In mainland China, “plaza” became a symbol of consumer capitalism. In conjunction with this shifting meaning of the square, the crowd, which used to gather on squares and march, is now seen as a potential threat. Crowds, unless orderly, organized or approved officially, are thus dismissed negatively as indecent in the post–Reform era. This distrust continues on the Internet. As Geert Lovink (2011) writes:

“This basic rule of how crowds gather, described by mass psychologists, is also operational on the Internet, as if the masses want to celebrate their own presence by demonstrating their sheer quantity... the swelling and density of crowds seems unstoppable (51).”

As *danmu* dominates the majority of video platforms, its regulation is already on the official agenda. Major livestreaming platforms now dedicate hundreds, sometimes thousands, of administrators to monitor livestreaming channels in real–time. The fear is not that comments may contain vocal critiques of the government. Messages are usually filtered on the client side before they are even sent, using frequently updated lists of blacklisted words. The more plausible motivation is the utmost distrust of the swelling crowd inherited from the general policing strategy in post–Reform China.

*Danmu is the visual effect of an assembly and affective flow of a marching crowd.* During sensitive periods such as anniversaries or important political events, Bilibili simply shuts down its *danmu* interface entirely.<sup>6</sup> It is not that they do not trust their own real–time censorship, but preventing the crowd from entering the “virtual square” of online videos/streams is always the safest bet. Given the huge cost of maintaining an army of real–time administrators and constantly updating monitoring algorithms, the goal of novel technologies is not just surveillance but actively pushing for a “healthy” public space of an orderly flowing highway, as opposed to a crowded public square of “polemical symphony.”

## REFERENCES

- An, T. 2016. “The Third Voyeurism.” *Masks the Journal O:NIX*, 47–54.
- Citton, Y. 2017. *The Ecology of Attention*. Cambridge, UK: Polity Press.
- Dai, J. 1999. “Exposure and Concealment: The nomenclature of Plaza.”  
Retrieved from [article.netor.cn](http://article.netor.cn) website.
- Galloway, A. 2012. *The Interface Effect*. Cambridge, UK: Polity Press.
- Galloway, A. R. 2006. *Gaming: Essays on Algorithmic Culture*. Minneapolis: University of Minnesota Press.
- Li, J. 2017. “The Interface Affect of a Contact Zone: Danmaku on Video–Streaming Platforms.” *Asiascape: Digital Asia*, 4, 233–256.
- Liao, R. 2014. “*Danmu* So Popular On China’s Online Video Sites That It Enters

6 In 2019, it was shut down from May 29 to June 6.



- The Cinema.” Retrieved from technode.com website.
- Lovink, G. 2011. *Networks Without a Cause*. Cambridge, UK: Polity Press.
- O’Donnell, M. 2013. “On Shenzhen Speed.” Retrieved from shenzhennoted.com website.
- Treske, A. 2013. *The Inner Life of Video Spheres*. Amsterdam: Institute of Network Cultures.
- Virilio, P. 1977 [2006]. *Speed and Politics*. Los Angeles, CA: Semiotext(e).
- Xu, C. 2019. “Bullet Time.” Retrieved from logicmag.io website.
- Weltevrede, E., Helmond, A., and Gerlitz, C. 2014. “The Politics of Real-time: A Device Perspective on Social Media Platforms and Search Engines.” *Theory Culture & Society*, 31 (6), 125–150.







RED-BRAISED PIG TAILS

# FUTURE RECIPES

---

未来食谱 | Xiaowei R. Wang

---

## RED-BRAISED PIG TAILS

Pig tail is a recent delicacy in China. Its texture is a complex journey through a range of sensations: satisfyingly chewy, melt-in-your-mouth fatty, and surprisingly crunchy, a pig tail is a condensation of all our favorite pork parts. There are many ways to prepare this cut of pork, but we find that red-braised is the most delicious, highlighting the tenderness of the fatty parts while also softening some of the tougher portions, like the tail's tip.

Tails were once considered common, but under the National Five Year Plan To Improve Pork in 2019, all tails were eliminated from Chinese bred pork. The National Five Year Plan To Improve Pork arose from pork industry consolidation and the introduction of advanced technologies in industrial pork farming, like AI and computer vision. A rising middle class in China demanded more cheap pork as a sign of prosperity. The government understood that food security and meeting food demands would lead to political stability. As a result, they consolidated China's small pork producers and encouraged industrialized farming under the National Five Year Plan To Improve Pork, which would leverage blockchain (to track provenance), genetic engineering, AI and computer vision to increase pork production while cutting costs.

Labor intensive, small-scale pork farming was restricted to heritage breed pigs and a maximum of 50 animals, as human farmers had restrictions on the level of efficiency in which they could watch over their pigs. Heritage breeds also caused issues with the rest of the production line: a diversity of breeds meant differently sized pigs and different ratios of fat to lean meat which resulted in non-standardized slaughtering, pork quality grading and pricing. As a result, China's pork industry followed in America's footsteps, where heritage breeds were for the large part eliminated and replaced with three major breeds, Yorkshire, Duroc and Landrace pigs.

As the pigs became standardized, computer vision models became more accurate, since cameras could quickly and easily identify registration marks branded on the pig's body, without incorporating new training data about obscure heritage breeds. The African Swine Fever scare in 2019 underscored the urgency of the National Five Year Plan To Improve Pork, to eliminate all small pork producers and focus on making a modern, hygienic pork industry.

Given pigs' susceptibility to disease, sources of contamination were decreased and removed entirely. One step along the process occurs during transport, where stressed pigs will bite each other's tails off while in tight quarters. In 2020, He Zuyong's pork lab at Sun Yatsen University in Guangdong pioneered a novel



technique for cloning gene-edited pigs. Part of the lab's work included gene editing pigs to take out their tails, preventing injury during transport, as well as optimizing and standardizing the pig for computer vision, in case the tail might obscure any registration marks.

There remain a few heritage pig producers in China, however. As of 2023, there are a handful of breeders in Guizhou as well as Guangdong. Such pigs are highly coveted, fetching up to 100,000 RMB. Each part of the pig is used, given the status of such pigs. The tail especially is prized, as a whole, unbitten tail is proof of heritage status. For special celebrations, this recipe for red-braised pig tail is sure to impress any banquet guest.



RED-BRAISED PIG TAILS (SPICES)

## RED-BRAISED PIG TAILS (RECIPE)

### INGREDIENTS:

½-inch stick of licorice  
 1 tbsp of ginger, minced finely  
 2 cloves of garlic, minced finely  
 ½ stick of Chinese cinnamon (cassia bark)  
 1 tbsp green Szechuan peppercorns  
 3 stars of anise  
 1 tbsp of sugar  
 1 bay leaf  
 1 cup of soy sauce  
 Oil  
 1 pig tail  
 2 eggs

### GARNISH:

Cilantro  
 Scallions

1. First, make the eggs (for ludan, or soy eggs). Boil for 7 minutes and 30 seconds. Remove from heat and immediately place in a cooling ice bath. Peel, set aside.
2. Fill a large wok with water and bring to a boil. Place the pig tail in the boiling water and poach for one minute. Remove the scum that floats at the top of the water. Remove pig tail and set aside.
3. Empty the water, making sure to dry the wok. In the dry wok, pour some oil. Place the tail into the wok, along with ½ a tablespoon of sugar. Turn the heat to medium to caramelize the tail on both sides. Remove the tail once the exterior has browned.
4. In the wok, keep the oil at medium. Add the minced garlic and ginger. Stir for a few minutes, until ginger and garlic become fragrant.
5. Place the oil, ginger and garlic into a clay pot. Add the pig tail, the two peeled eggs and the rest of the spices: cinnamon, licorice, Szechuan peppercorn, anise and bayleaf. Add the other ½ tablespoon of sugar and soy sauce. Place clay pot on stove and cover.
6. Simmer at medium until slightly bubbling, then turn heat to a low simmer for up to 2 hours. The longer you simmer, the more flavorful the meat and eggs will become.
7. Remove tail and eggs from heat, plate and garnish with scallions and cilantro.

Noodle Number

区块面

Place noodle strands flat and measure length of each.  
Make note of length

A  5 in

B  3 in

C  7 in

D  4 in

Take noodle A and link it to noodle B

Take measurement of noodle A and multiply it by noodle B to get z.  
Then find x where  $z + x = 0$

Multiply x by the next noodle, C to get a new product, y.  
Then find x where  $y + x = 0$

Repeat until all strands have been incorporated.

For example:

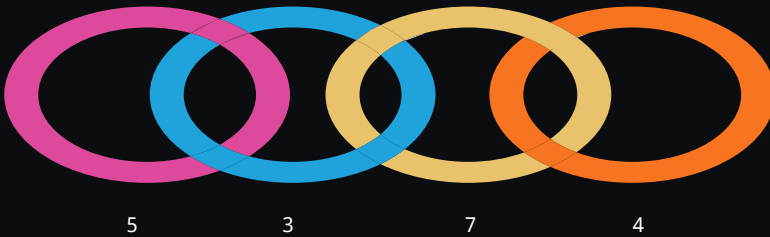

$$5 * 3 = 15$$

$$15 + x = 0$$

$$x = -15$$

$$-15 * 7 = -105$$

$$-105 + x = 0$$

$$x = 105$$

Noodle  
Number: -420

$$105 * 4 = 420$$

$$420 + x = 0$$

$$x = -420$$

## BLOCKCHAIN NOODLES

China is home to some of the biggest cryptocurrency and blockchain firms. Companies like Binance and Bitmain were founded in China and continue to operate within the country so long as regulation allows.

Starting in the late 2010s, the government has encouraged the growth of blockchain within China. As a form of “immutable storage,” blockchain allows for a decentralized, tamper-resistant ledger. Due to its tamper-resistant nature, records cannot be falsified, which is ideal for a range of industries from food safety to payment records.

Blockchain’s status as a cutting-edge technology in the late 2010s also made it a marketing buzzword in addition to utilitarian technology. Food especially became a way to make money off the blockchain. Red wine from Great Wall, tracked on the blockchain to prove authenticity and provenance, fetched hundreds of RMB. Fish, pork and chicken were all tracked on the blockchain as part of poverty alleviation projects in rural China, designed to increase the profit margins of small farmers. One project, GoGoChicken, stored the information of each free-range chicken on a private blockchain, with each chicken’s weight, date slaughtered and number of steps taken in the pasture on the blockchain. These chickens could be purchased by wealthy Shanghaiites for the steep price of 200 RMB per chicken.

Such blockchain food projects are still targeted towards the wealthy 1% of people who can afford such food, with only a small amount of extra earnings trickling down towards impoverished, rural farmers. Blockchain noodles are a *shanzhai*-style people’s blockchain, first formulated by a farmer in Guizhou, whose wife owned a noodle stand. The wife kept hearing the word “blockchain” from her WeChat feed, and decided to investigate for herself. Through the village’s poverty alleviation fund, she set up an Ethereum mining rig for herself, using cheap wind power and a used GPU that her daughter brought back from the city.

As one of the first Ethereum miners in town, she began advertising her blockchain noodles: you’ll like the taste of them or your ETH back! Each noodle is carefully measured and then strung onto another noodle, link by link. A set of mathematical computations are done to all the links in a process similar to the blockchain hashing system. At the end, a single number, the Noodle Number, results from the noodle chain and is put on the noodle bowl. When the buyer pays for the noodles, the Noodle Number is included as a data payload in the transaction.

The farmer’s wife profited heavily off her blockchain noodles and received massive amounts of media attention, including a visit from Changpeng Zhao, CEO of Binance who declared she had the tastiest noodles in China. In 2025, after opening a successful blockchain noodle chain, she open sourced her recipe for blockchain noodles.

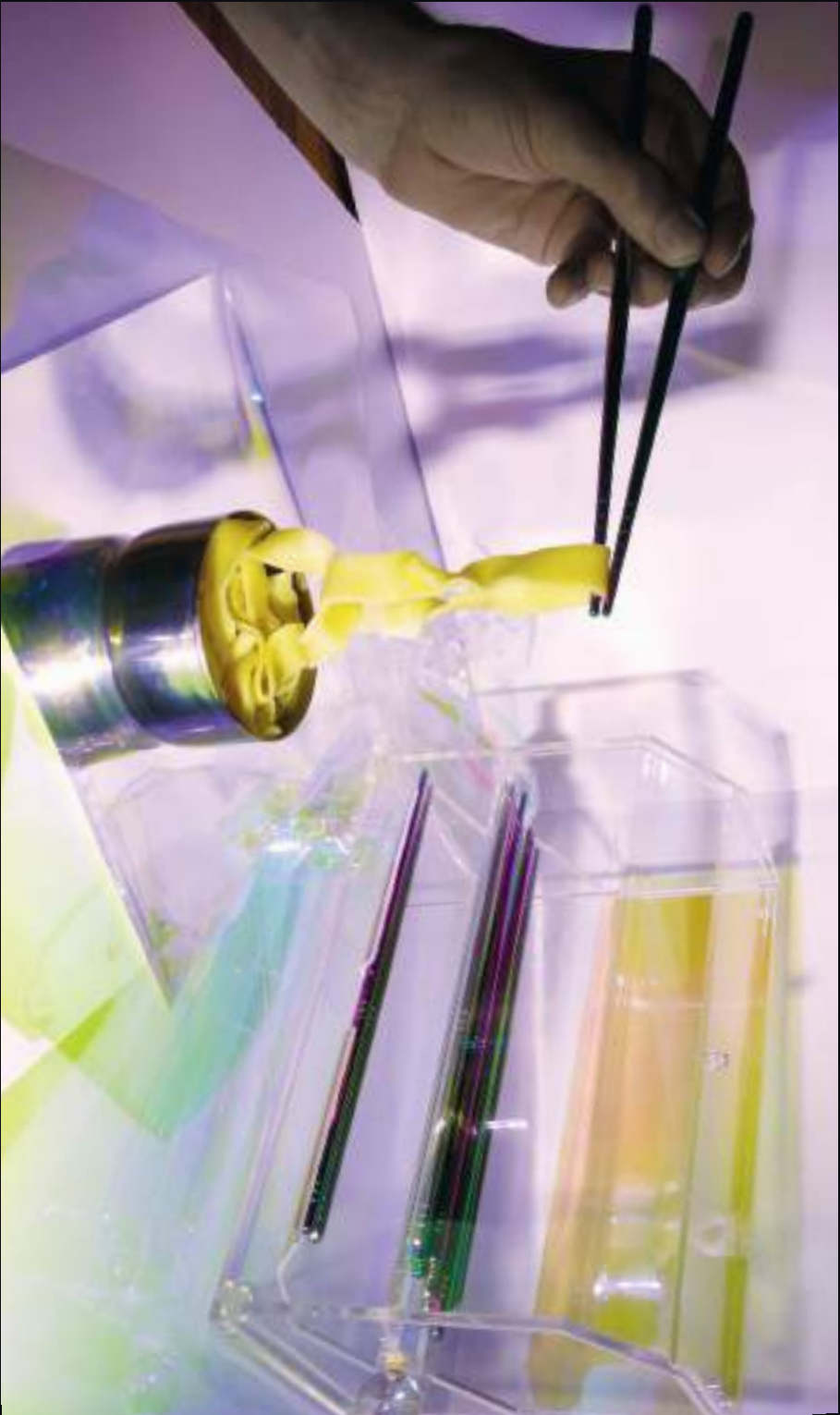

## BLOCKCHAIN NOODLES (RECIPE)

### INGREDIENTS:

White flour  
Semolina flour  
Water  
Salt  
Vegetable oil  
Rice flour

### FOR THE SAUCE:

Chili oil (to make your own, see below recipe)  
Soy sauce  
Black vinegar  
Cilantro  
Green onion

### TO MAKE THE NOODLES:

1. Combine white flour, semolina flour, salt and water in suitable proportions. A rule of thumb is half semolina and half white flour—the semolina has a higher gluten content and will add stretchiness, while the white flour adds structural strength to the noodles. For approximately 4 full-sized servings of noodles, use  $1\frac{1}{2}$  cups semolina and  $1\frac{1}{2}$  cups white flour. Add 1 teaspoon of salt for every 3 cups of flour. Combine the dry ingredients in a large bowl. Slowly add warm water to the dry ingredients until it forms a wet dough. The dough should not be dry, but will not stick to the bowl when moved.
2. Knead dough for 8 minutes. Let rest for 15 minutes, covered, to prevent the dough from drying out.
3. Divide dough into small 1 inch balls, about 50 grams each. Roll out each ball lightly so it forms a small oval shape. Don't make this oval shape too thin—it should still be about  $\frac{1}{4}$  inch thick.
4. Oil the top and bottom of the oval shaped dough and repeat the process of rolling and oiling for each small ball. Set aside, cover. Let the oval shaped dough pieces rest for up to 1 hour.
5. After 1 hour, take one of the oval shaped pieces and roll out thinly on a floured surface. Dust both sides with rice flour. Fold the thin dough in the center, and slice into noodle sized strips (about  $\frac{1}{4}$  inch wide). Dust with more rice flour and stretch the noodles slightly before setting aside on a sheet pan. Link each noodle together, forming a chain. Repeat this process for each of the oval shaped dough pieces.
6. For each noodle chain, note the length of each strand. Follow the Noodle Number diagram to get the Noodle Number. Note this Noodle Number down to put on the bowl.



BLOCKCHAIN NOODLES

7. Noodles can be stored for three days in the fridge. When cooking, boil water and place noodles into the hot water. Noodles only take a few minutes to cook in boiling water—be careful not to overcook.

TO MAKE THE CHILI OIL:

1. In a small pan, simmer a cup of oil with star anise, cassia bark and a small piece of ginger. Simmer for up to 2 hours to infuse the oil.

2. In a separate, stainless steel or heat-proof bowl, place chili flakes (use a Szechuan blend of chili flakes, such as Facing Heaven chilis). After the oil has been infused, turn the heat up high to get the oil very hot. Pour the hot oil over the bowl of chili flakes to crisp the chili flakes slightly. The oil might spatter, so be careful. If the oil bubbles up on the sides, this means the temperature was correct.

3. Let the oil cool.

4. To make the noodle sauce, combine soy sauce, vinegar and chili oil to taste. Top with green onions and cilantro.

5. Make sure to dress the noodles immediately before serving, not too far in advance or noodles will become soggy.

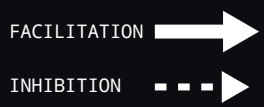
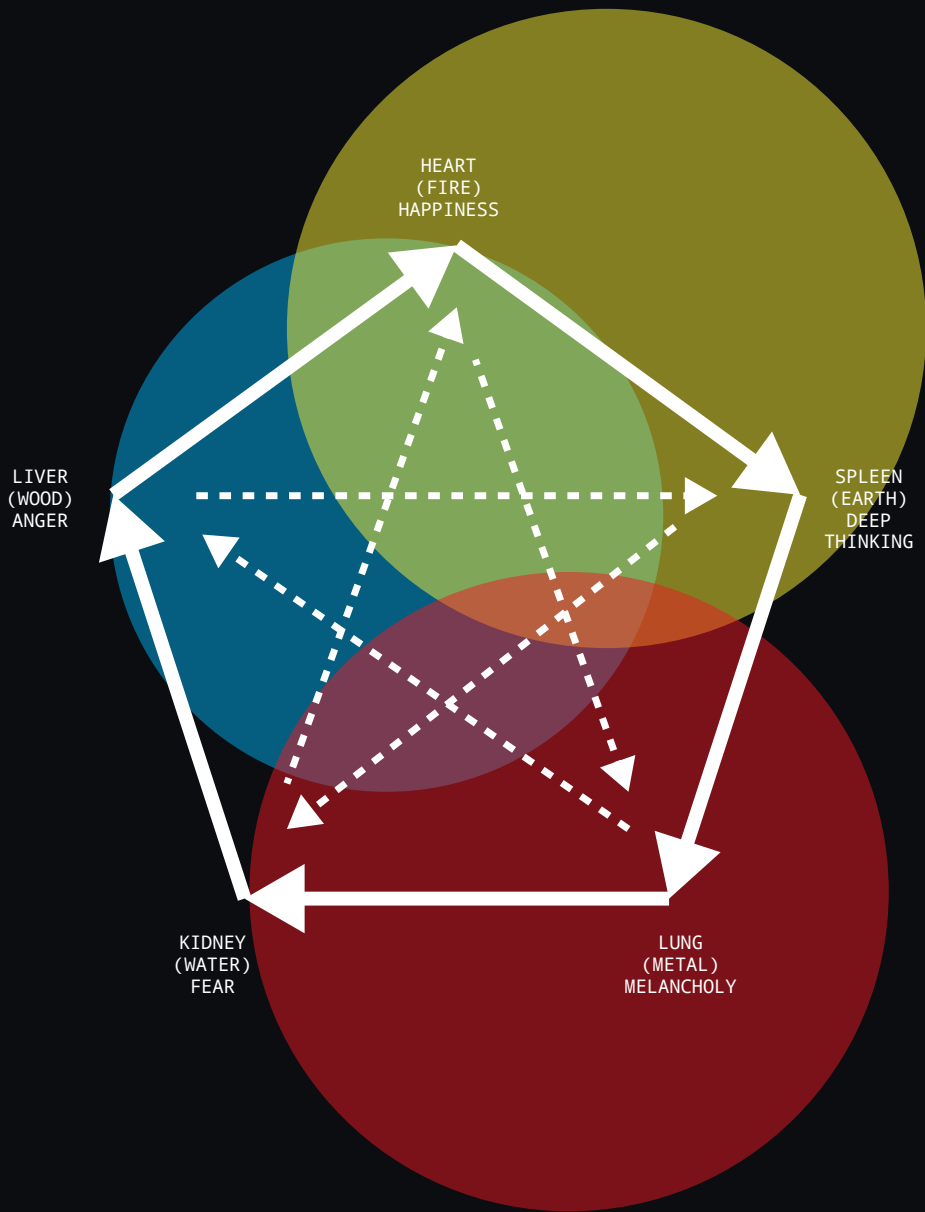

## A.I. PORRIDGE

In both the 1980s and 2020s, researchers suffered an “AI winter,” where funding and public interest in artificial intelligence was low. While companies and CEOs in the West had promised self-driving cars and fully sentient machines by 2020, neural networks used in AI were unable to deliver, with the specificity of training data limiting what an AI model could be used for. Neural networks were only capable of doing single-use tasks such as identifying people in photos, but were unable to scale to other purposes. Despite the attempt to develop “artificial general intelligence,” political and popular support for such endeavors was low, decreasing funding from private and public sectors significantly.

In the midst of this AI winter, a group of Chinese scientists and researchers at the joint Tsinghua–Alibaba AI lab took up the task of generalizing AI models, taking their cue from Chinese medicine. In Western medicine, the most important organ is the brain and all life stems from the brain and mental thinking. In Chinese medicine, there are eleven vital organs and this list does not include the brain. Within these eleven vital organs is the subcategory of five zang, or key organs (heart, liver, lungs, spleen, kidney). Brain functions are scattered throughout the body, and brain function itself is considered a holistic function rather than isolated to a single organ. Emotions such as anger, deep thinking, melancholy and fear are governed by the liver, spleen, lungs and kidney. The dynamics of the body in Chinese medicine have been compared to systems in chaos theory, or hybrid dynamic systems (see Sakatani, Kaoru. “Concept of Mind and Brain in Traditional Chinese Medicine.” *Data Science Journal*, vol. 6, 2007, doi:10.2481/dsj.6.s220.), where the function of each organ is more important than the structure.

Researchers managed to create a pre-trained neural network with electrical inputs and outputs from a combination of artificial and human organs. This hybrid machine was able to perform broader tasks without further training data, but was still not fully sentient. Scientists believe further development is needed into the concepts of creativity and language to fully understand where other parts of the body’s creative and language functions reside. Yet the ability of the machine to extend its thinking was the first breakthrough in a long, icy AI winter.

The system did not have access to typical conduits for *qi* (the defining force in Chinese medicine), such as hair, skin or muscle, to send to the machine–meat hybrid. In order to nourish this system of organs and neural nets, it had to be constantly fed tonifying food: foods to nourish the vital organs in the system.

This porridge was developed by researchers to nourish and tonify the system, but can be used as a nourishing and tonifying system for the human body as well. It’s quick and easy to make. You can use a pressure cooker, an Instant Pot or a rice cooker with a porridge setting.



AI PORRIDGE

## A.I. PORRIDGE (RECIPE)

### INGREDIENTS:

½ cup quinoa

½ cup amaranth

Roasted pumpkin seeds

1 tbsp fat of your choice (butter, oil, pork lard)

Maple syrup for sweetening

Sticky rice (glutinous rice)

Water

1. Make the porridge by combining the glutinous rice with water in a ratio of 1:5 (for example, 1 cup rice to 5 cups water). If using the stovetop, set heat on medium until mixture boils, then turn to low. Otherwise, use the porridge setting on your rice cooker.

2. While the porridge is cooking, make the popped quinoa and amaranth for the porridge. This process is similar to making popcorn. However, do not use oil—use a dry pot. On the stovetop, heat a large, deep pot on high for a few minutes. The pot should be deep since the amaranth and quinoa will jump during popping, and this will prevent amaranth from popping out of the pan. After a few minutes, place a few grains of amaranth in the pot to test if the base is hot enough. If they pop immediately, the pot is at the correct temperature. Discard the test amaranth. Add enough amaranth to cover the bottom of the pot, turn heat to low and allow the amaranth to pop, while shaking the pot so the grains move around. Not all grains will pop, so once the popping starts to slow, remove from heat. Pour the popped amaranth into a sieve to sift out the popped grains and discard the unpopped ones.

3. Follow the above process for quinoa, taking special care to shake the pot while the quinoa grains are popping so that they do not burn. Combine the popped quinoa and amaranth and set aside.

4. Once the rice in the porridge has become soft enough for your liking, place into a bowl. Mix a teaspoon of quinoa and amaranth mixture with one cup of porridge. Add the fat (a pat of butter), and top with maple syrup and pumpkin seeds.







# CONCLUSION

REALTIME set out to describe and analyze the multiple shapes of China's urban and technological transformation. The book illustrates the diversity of practices evolving from common origins (e.g., the Internet, urban development, mobile telephony, e-commerce) in light of the country's density, scale and temporality.

The administration of writing and the planning of cities have been marked by important disruptions, while exhibiting noticeable historical continuity. The case of Shenzhen highlights the permanent adaptation to immediate constraints, resulting in the development of a new planning model and discourse to be reproduced in urban contexts elsewhere. Standardization efforts for 5G mobile telephony further illustrate the ambition, speed and scale at which Chinese companies and the government plot technological trajectories domestically and abroad. In spite of different visual representations, ideologies of AI show striking resemblances on both sides of the Pacific.

In their own way, *shanzhai* mobile phones and *danmu* comments attest to the uniquely creative technological practices crafted in China. The ethnographic account of Shenzhen's Huaqiang area describes the intricate relationships between the emergence of digital technology and urban transformation. The case of Taobao villages shows that new spatial and economic organizations exist and prosper on the fringes of larger technological systems. These examples remind us of the central importance of human agency in the hybridization of technology and space, even when hardly visible.

Considering the multiple scales and locations of urban transformations raises significant methodological difficulties for the researcher. On-hand approaches borrowed from maker cultures provide a rich inspiration to overcome these challenges and integrate findings and viewpoints from diverse communities. Fiction may eventually help us to nurture a sensory (and culinary) relationship with the future of technology.

More than reaching definitive statements about China, REALTIME constitutes a modest attempt at capturing the pace, scale and depth of the country's complex reality. The book gathers different views and perspectives with the hope of casting a different light on the changes occurring not only within China, but across the world.

The extension of the practices and phenomena observed here, and their correlation to changes in natural and sociopolitical ecosystems, is yet to be explored further. How are these real-time transformations reshaping the human condition? What sort of new physical and conceptual spaces are required to describe and analyze them? And furthermore, how can such spaces exist beyond actual scientific and national boundaries?

# CREDITS

---

## [01] MAKING DIGITAL CHINA

---

- p.16 Public Domain
- p.18 Source: Patent US2613795A "Chinese typewriter" by Lin Yutang, 14/10/52.  
Public Domain (patent expired)
- p.20 (CC-BY-2.0) Robert Scoble
- p.22 Source: Paris, BnF, Manuscrits orientaux.  
Public Domain
- p.24 Source: *Science*, 12 Oct 1973, Vol. 182, Issue 4108, pp. 134-140  
© Science
- p.26 Top: © People's Daily  
Bottom: © UPI
- p.28 (CC-BY-2.0) Z Jason
- p.30 Top: (CC BY-SA 3.0) 余华峰  
Bottom: (CC BY 3.0) 唐明亮
- p.32 © Liu Xiangfu
- p.34 CCTV © 2016
- p.36 © Tencent

---

## [02] PLANNING: FROM MODEL TO MODULES

---

- p.40 Source: Nancy Shatzman Steinhardt, *Chinese Imperial City Planning*, University of Hawai'i Press; New edition (April 30, 1999)
- p.42 Source: Nancy Shatzman Steinhardt, *Chinese Imperial City Planning*, University of Hawai'i Press; New edition (April 30, 1999)
- p.44 Source: Wu, Hung. 2005. *Remaking Beijing: Tiananmen Square and the Creation of a Political Space*. Chicago: The University of Chicago Press.
- p.46 Public Domain
- p.48 Public Domain
- p.50 Source, top: Shenzhen Comprehensive Development Draft Plan, 2007-2020  
Source, bottom: Zacharias, J., and Y. Tang. 2010. "Restructuring and Repositioning Shenzhen, China's New Mega City." *Progress in Planning* 73: 209-249.
- p.52 Source: 可可KekeTV ©
- p.54 Google Earth Engine  
Source: Nick Van Mead, "The Great Sprawl of China: Timelapse Images Reveal 30-year Growth of Cities." *The Guardian*, March 21, 2017.  
Top: © Dennis de Bel  
Bottom: © SeanPavonePhoto
- p.56 © Dennis de Bel
- p.58 © Dennis de Bel

---

## [03] PRODUCING STANDARDIZATION: CHINESE BLOCKS IN NETWORKS

---

- p.62 (CC-BY-2.0) DISNOVATION.ORG
  - p.64 Source: "Well Under Way." (2018, Oct 27). *The Economist*, 429, 89.
  - p.66 Source: Woetzel, Jonathan, et al. (2019). *China and the World: Inside the Dynamics of a Changing Relationship*. McKinsey Global Institute.
  - p.68 Source: Meng et al. (2018) based on the UIBE GVC indexes derived from the ADB 2018 ICIO table.
  - p.70 Source: *The New York Times*. 2018. "How China Took Over Your TV" November 18, 2018.
  - p.72 Source: Woetzel, Jonathan, et al. (2019). *China and the World: Inside the Dynamics of a Changing Relationship*. McKinsey Global Institute.
  - p.74 Source: "Welcome to Silicon Delta; Innovation." (2017, Apr 08). *The Economist*, 423, 9.
  - p.76 Source: Fomalhaut Techno Solutions
  - p.78 Source: Steve VanPuyvelde and Randy Thompson, ShopJimmy.com (NY Times)
  - p.80 (CC-BY-2.0) DISNOVATION.ORG
  - p.82 (CC BY-SA 2.0) Maersk Line
  - p.84 (CC-BY-2.0) DISNOVATION.ORG
-

# 图片版权名单

---

## [04] SHANZHAI ARCHEOLOGY

---

p.88-108 (CC-BY-2.0) DISNOVATION.ORG  
p.88 Top: Public Domain  
Bottom: © Victoria and Albert Museum, London

---

## [05] GHOSTS OF SHENZHEN

---

This text was made possible by the invaluable support of many great individuals and the Mondrian Fund NL, 33 Space, Handshake 302, Institute For Provocation Beijing.

p.112-124 © Dennis de Bel

---

## [06] LEARNING ABOUT MAKERS IN CHINA

---

This study was conducted with the support of the SNFS for the project "Makerspaces in China" (2016-2020) at École Polytechnique Fédérale de Lausanne (EPFL).

p.128, 132, 136, 140, 146, 150, 152 © Anaïs Bloch  
p.130, 134, 138, 142, 144, 148 © Monique Bolli

---

## [07] CHINA.AI

---

p.156 Source: "红色云"助你党课随身听 by 膜包不膜蛤 posted on 8月 31, 2018  
© China Digital Times  
p.158 © "A.I. Love" MV by Wang Leehom © 2017 Hong Sheng Culture, Inc.  
p.160 © Global Views - Commonwealth Publishing Group  
p.162 Top: © CGTN  
Bottom: CITIC press  
p.164 Top: © Xinhua news  
Bottom: © Gabriele de Seta  
p.166 Xinhua news anchors  
p.168 Screenshot Google & Baidu results by Gabriele de Seta

---

## [08] THE AFORMAL ARMATURES OF A NEW AUTONOMOUS URBANISM

---

p.172-180 © Jason Hilgefert & David Li

---

## [09] SPEED POLITICS OF DANMU

---

p.184 Top: (CC-BY-SA-4.0) H2NCH2COOH  
p.184 Bottom: © Dino Ge Zhang  
p.186-188 © Dino Ge Zhang

---

## [10] FUTURE RECIPES

---

p.202-214 © Xiaowei Wang

---

# BIOS

---

CLÉMENT RENAUD is a technologist, scientist and artist exploring new digital spaces and representations in China and worldwide. He is a research collaborator at the College of Humanities at EPFL, and a research associate at the Institute of Complex Systems (IXXI) at ENS de Lyon.

---

FLORENCE GRAEZER BIDEAU is Senior Scientist at the College of Humanities, EPFL, Visiting Professor at the Politecnico di Torino since 2015 and Associated Researcher at the China Room Research Group and South China-Torino Collaboration Lab since 2016. Her domains of expertise are the anthropology of East Asia, critical heritage studies and urban studies. She is the principal investigator of the "Makerspaces, politics, and communities of innovation in contemporary China" project, financed by the Swiss National Science Foundation between 2016 and 2019.

---

MARC LAPERROUZA is scientist and lecturer at the College of Humanities, EPFL and at HEC, University of Lausanne. His domain of expertise is economic development with a focus on China and emerging markets. He is co-investigator of the "Makerspaces, politics, and communities of innovation in contemporary China" project, financed by the Swiss National Science Foundation between 2016 and 2019.

---

MARIA ROSZKOWSKA is an artist, designer and co-founder of the DISNOVATION.ORG working group. From 2010 she conducted research with EnsadLab Paris, before joining Intégral Ruedi Baur, a cultural design studio based in Paris. She designed and coordinated "Don't Brand My Public Space!", a 3 year research project on the issue of application of branding strategies by cities. In 2015 she edited "The Pirate Book", an anthology on media piracy.

---

DISNOVATION.ORG is a working group based in Paris, founded by Nicolas Maigret and Maria Roszkowska. Existing at the intersection of contemporary art, research and hacking, the collective develops situations of disruption, speculation, and debate in order to question dominant techno-positivist ideologies, and to stimulate post-growth narratives. They edited "The Pirate Book", an anthology on media piracy and their research includes artworks, curation and publications. In 2018, they received a Design Trust Grant (Hong Kong) for a research project into China's Shanzhai culture. They are currently visiting researchers at the University of California, Irvine.

---

DENNIS DE BEL is a hands-on artistic researcher, educator and radio amateur. His practice oscillates between various configurations focusing on collectively exploring hardware, wetware and various waveforms. In 2017 he co-founded Varia, a physical space for developing collective approaches toward everyday technology based in Rotterdam. De Bel holds an MA from the Piet Zwart Institute (NL) and most recently participated in the artist in residency program of the Institute for Provocation in Beijing (2018). [dennisdebel.nl](http://dennisdebel.nl)

---

MONIQUE BOLLI is a social anthropologist specializing in Asian Studies. She is currently finalizing her PhD at EPFL on the politics of innovation in urban China, more specifically on the maker movement in Shanghai, Shenzhen, Beijing and Addis Ababa. Prior to joining EPFL, she worked at the International Cooperation Division of the Embassy of Switzerland in China on policy dialogue for poverty reduction, Public-Private Partnerships for Development (PPDP) and trilateral cooperation.

---

# 作者简介

---

ANAÏS BLOCH is an artist, researcher, and educator. After obtaining a bachelor's degree in Product Design (University of Arts and Design in Lausanne - ECAL), she studied her master's in Material Culture in Anthropology (University College London - UCL). Her work explores the boundaries between anthropological research methods, art and design.

---

EMANUELE PROTTI is an architect and PhD candidate in Architecture History and Design at Politecnico di Torino. He works inside the Future Urban Legacy Lab at Politecnico di Torino along with personal research on the phenomenon of Urban Manufacturing, temporary architecture and adaptive reuse. Since 2014, after studying in Barcelona and São Paulo he has collaborated with different professional realities such as Carlo Ratti Associati, Plateau Collaboratif, and UdA Marcante-Testa. In 2016 in collaboration with Plateau Collaboratif he won the international competition for the redevelopment of the industrial sector of Pasubio in Parma.

---

GABRIELE DE SETA is a media anthropologist. He holds a PhD in Sociology from the Hong Kong Polytechnic University, was a Postdoctoral Fellow at the Institute of Ethnology, Academia Sinica in Taipei, and is currently a Postdoctoral Researcher at the University of Bergen. His research work, grounded in ethnographic engagement across multiple sites, focuses on digital media practices and vernacular creativity in China. He is also interested in experimental music scenes, internet art, and collaborative intersections between anthropology and art practice. More information is available on his website paranom.asia.

---

JASON HILGEFORT is an urbanist/architect and founder of Land+Civilization Compositions, Aformal Academy, and The Institute for Autonomous Urbanism; he is a Lecturer in Urban Design at Hong Kong University and is currently executing his PhD at RMIT.

---

DAVID LI has been contributing to open source software since 1990. He is a member of the Free Software Foundation, a contributor to Apache projects and board director of ObjectWeb. In 2010 he co-founded XinCheJian, the first hackerspace in China to promote hacker/maker culture and open source hardware. In 2011 he co-founded Hacked Matter, a research hub on the maker movement and open innovation. In 2015 he co-founded Maker Collider, a platform to develop next generation IoT from the maker community. He is also the executive director of Shenzhen Open Innovation Lab which facilitates the collaboration between global smart hardware entrepreneurs and Shenzhen Open Innovation ecosystem.

---

DINO GE ZHANG is a media anthropologist. You can find his work at anthropos.live.

---

XIAOWEI WANG is an artist, engineer and researcher based between the two Bay Areas. They research technology in rural areas, with a focus on food systems and the importance of landscape in a digital world.

---

# IMPRESSUM

---

REALTIME: MAKING DIGITAL CHINA

---

## EDITORS

Clément Renaud, EPFL  
Florence Graezer Bideau, EPFL  
Marc Laperrouza, EPFL

## GRAPHIC DESIGN

Maria Roszkowska, DISNOVATION.ORG

## AUTHORS

Clément Renaud, EPFL Lausanne, CH  
Florence Graezer Bideau, EPFL Lausanne, CH  
Marc Laperrouza, EPFL Lausanne, CH  
Monique Bolli, EPFL Lausanne, CH  
Emanuele Protti, Polytechnico de Torino, IT  
Anaïs Bloch, HEAD Geneva, CH  
Maria Roszkowska, DISNOVATION.ORG  
Nicolas Maigret, DISNOVATION.ORG  
Dennis de Bel, Willem De Kooning Academy, Rotterdam, NL  
Gabriele de Seta, Academia Sinica, Taipei, TW  
Jason Hilgefert, Hong Kong University / LCC, HK  
David Li, SZOIL, Shenzhen CN  
Dino Ge Zhang, RMIT University, Melbourne, AU  
Xiaowei R. Wang, Researcher & Designer, San Francisco, US

## COPY-EDITING

Rik Godwin and Jo Nicoud-Garden

## CREDITS

PURR © 2020

This book was made with the support of the SNFS for the project "Makerspaces in China" (2016-2019) and the Swiss Institute of Technology at Ecole Polytechnique Fédérale de Lausanne (EPFL).

We are very grateful to all the people who supported the project formally or informally, from close or afar. Our thanks go in particular to the maker communities in Chengdu, Shanghai and Shenzhen for making along, to Swissnex China for sponsoring a number of events, to Lucas Giossi for his editorial support and to the College of Humanities at EPFL for hosting the project.

---





REALTIME (实时)

*NOUN*

THE FEELING THAT OCCURS WHEN CHANGES AROUND APPEAR VERY FAST, LOUD AND REAL—NOT ONLY WITHIN CHINA, BUT ACROSS THE ENTIRE WORLD.

