

Coupling superconducting magnet and refrigerator thermal-hydraulic models for nuclear fusion applications

*Original*

Coupling superconducting magnet and refrigerator thermal-hydraulic models for nuclear fusion applications / Bonifetto, R.; Brighenti, A.; Savoldi, L.; Zanino, R.. - In: IOP CONFERENCE SERIES: MATERIALS SCIENCE AND ENGINEERING. - ISSN 1757-8981. - STAMPA. - 502:(2019), p. 012130. (Intervento presentato al convegno 27th International Cryogenics Engineering Conference and International Cryogenic Materials Conference 2018, ICEC-ICMC 2018 tenutosi a Oxford (United Kingdom) nel September 3 - 7, 2018) [10.1088/1757-899X/502/1/012130].

*Availability:*

This version is available at: 11583/2785234 since: 2020-01-26T03:34:52Z

*Publisher:*

Institute of Physics Publishing

*Published*

DOI:10.1088/1757-899X/502/1/012130

*Terms of use:*

This article is made available under terms and conditions as specified in the corresponding bibliographic description in the repository

*Publisher copyright*

IOP postprint/Author's Accepted Manuscript

"This is the accepted manuscript version of an article accepted for publication in IOP CONFERENCE SERIES: MATERIALS SCIENCE AND ENGINEERING. IOP Publishing Ltd is not responsible for any errors or omissions in this version of the manuscript or any version derived from it. The Version of Record is available online at <http://dx.doi.org/10.1088/1757-899X/502/1/012130>

(Article begins on next page)

PAPER • OPEN ACCESS

## Coupling superconducting magnet and refrigerator thermal-hydraulic models for nuclear fusion applications

To cite this article: R Bonifetto *et al* 2019 *IOP Conf. Ser.: Mater. Sci. Eng.* **502** 012130

View the [article online](#) for updates and enhancements.



**IOP | ebooks™**

Bringing you innovative digital publishing with leading voices to create your essential collection of books in STEM research.

Start exploring the collection - download the first chapter of every title for free.

# Coupling superconducting magnet and refrigerator thermal-hydraulic models for nuclear fusion applications

R Bonifetto<sup>1</sup>, A Brighenti<sup>1</sup>, L Savoldi<sup>1</sup> and R Zanino<sup>1,2</sup>

<sup>1</sup> NEMO Group, Dipartimento Energia, Politecnico di Torino, Italy

<sup>2</sup> Corresponding author. E-mail: [roberto.zanino@polito.it](mailto:roberto.zanino@polito.it)

**Abstract.** Helium refrigerators will provide the needed cooling power to the superconducting magnets of future magnetic fusion reactors, e.g. ITER, JT-60SA, EU DEMO. Reliable simulation tools are required to model the magnets-refrigerator coupling, in order to cope with feedbacks affecting the overall system dynamics. Here we couple the 4C code for the analysis of thermal-hydraulic transients in superconducting magnets with a refrigerator model developed in Modelica. The results of the new tool are compared with experimental data from the first phase of an ITER CSMC cool-down, from 300 K to 80 K.

## 1. Introduction

Historically, models for magnets, e.g. [1], [2], [3], and models for refrigerators, e.g. [4], [5], [6], have been developed separately in the nuclear fusion community.

The 4C code [7] has followed a similar pattern, as it was originally developed to simulate thermal-hydraulic transients in superconducting (SC) magnets, including their cooling circuits, up to the saturated liquid He (LHe) bath used e.g. in ITER to smooth the thermal load from the magnets to the refrigerator, which is pulsed in view of the pulsed operation intrinsic of a tokamak reactor. However, a few years ago the development of a model for the refrigerator was started, and some preliminary but encouraging results were presented at different conferences [8], [9].

This traditional approach of separating two strictly coupled systems on the one hand simplifies in a significant way the problem from the computational point of view, but on the other it does not allow to include in the models some important feedback effects, see figure 1. For instance, if we consider a typical cool-down (CD), a general constraint applied to the maximum rate of decrease of the inlet helium temperature is that it cannot be too fast and in particular not so fast to give rise to temperature differences inside the magnet at any time larger than, say, 50 K in ITER [10], so that conditions monitored on the magnets in principle affect the operation of the refrigerator. On the other hand, the simulation of the effects of the abovementioned pulsed heat load on the refrigerator clearly also requires a model which includes both the latter and the magnets where the pulsed heat load is coming from, and the development of suitable control strategies for, e.g., the smoothing of the heat load to the refrigerator [11] requires the models of the refrigerator and that of the magnets to be tightly coupled.

In this paper we present the coupled model and apply it to the simulation of an ITER Central Solenoid (CS) Mode Coil (CSMC) CD from 300 K to 80 K, comparing the results with experimental data.

## 2. Model description

The model implements a transient description of the coupled magnets and refrigerator system as shown in figure 2.



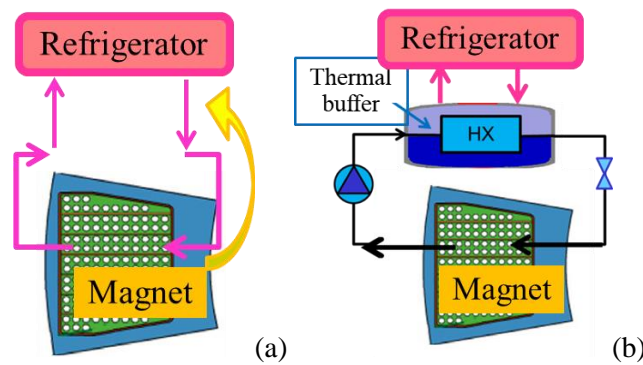

**Figure 1.** (a) Typical operation during magnet CD: the maximum allowable rate of decrease of the temperature at the magnet inlet driven by the refrigerator depends on the maximum temperature difference on the magnet, which is limited by structural constraints. (b) Typical operation during plasma pulses: a saturated LHe bath is used as a thermal buffer to smooth the heat load from the magnets to the refrigerator.

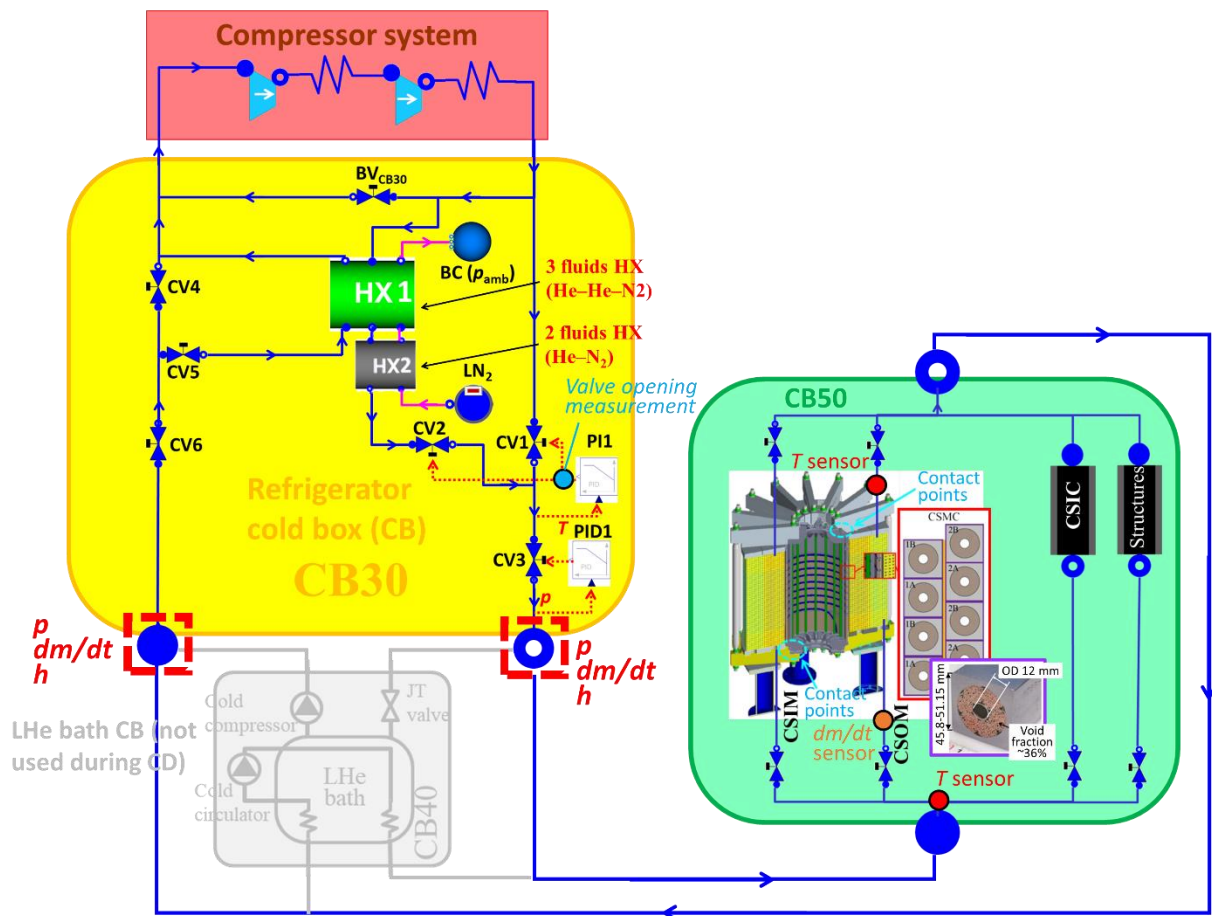

**Figure 2.** Sketch of the CSMC and refrigerator coupled model, developed here for the analysis of a typical CSMC CD. (The CB40 cold box, containing the saturated LHe bath/buffer, is not used during the CD, but is shown here nevertheless for the sake of completeness.)

The CSMC [12] is layer-wound two-in-hand, with 36 cable-in-conduit conductors (CICC) arranged in 18 layers: 10 layers in the inner module (IM) and the remaining 8 layers in the outer module (OM). It may host in its bore, as in the case analysed in this paper, a single-layer insert coil (IC). The IC (the CSIC tested in 2015 [13], in the case at hand) supporting structures are also included in the model by

selected 2D cuts and their cooling channel. Radiative/conductive heat transfer with the environment is neglected. The details of the model can be found in [14].

The refrigerator model implements the Collins cycle, representative of most refrigerators adopted for the cooling of SC magnets in fusion reactors. It includes a two-stage, inter- and post-cooled compressor system, and the refrigerator cold box (CB) CB30. The latter contains a bypass valve, several control valves (CV), one two- and one three-fluid heat exchangers, a Proportional-Integral (PI) controller of the temperature and a Proportional-Integral-Differential (PID) controller of the pressure, acting on CV3, both at the outlet of CB30/inlet of the CSMC, as well as inlet and outlet manifolds providing the needed LN2 flow.

While all automatic controls have been implemented in the model, manual control actions are not infrequent during the CSMC CD and may constitute a principle problem for the simulation. Here, e.g., all manual valve openings, which have been recorded, are prescribed in input in the simulation, but not all manual control actions have been recorded.

Finally, at the interface between CB30 and the cold box CB50 (dashed square nodes in figure 2), which contains the CSMC, the CSIC, and the structures, two equations are defined:

- $p$ , an “effort-type” variable [15], is prescribed to be the same (on both sides of each interface);
- the algebraic sum of the  $dm/dt$  (a “flow-type” variable [15], positive when entering the interface) must be equal to zero at each interface, in order to satisfy the mass conservation.

The third interface variable, i.e. enthalpy  $h$  (related to  $p$  and temperature  $T$ ), is a “stream-type” variable [15], which is advected from the upstream to the downstream CB.

### 3. Comparison of the 4C magnet and refrigerator model results with experimental data from a CSMC cool-down from 300 K to 80 K

We present here the results of the magnet and refrigerator coupled model for the first phase of the CSMC CD, i.e. from room temperature to 80 K. (The second phase of the CD requires to extend the model of figure 2, including turbines and the JT valve; this further development is currently ongoing.)

Although the magnet model includes the whole CSMC and CSIC, in the presentation of the output of the code we will focus on the CS Outer Module (CSOM), as the longer cooling channels make it more interesting considering that hot-spots could consequently be more likely to arise during the CD.

All refrigerator components in figure 2 are characterized as prescribed in the specs, except an ad-hoc pressure drop estimation adopted for the circuit piping, when detailed datasheets were not available.

One of the most important items in the transient analysed here is the evolution of the opening of the control valves CV1 and CV2, which is shown in figure 3 (CV4 and CV5 are 50% open and CV6 is 100% open during the entire first phase of the CD shown here). Unfortunately, as indicated in the figure by the 🖱️ symbols, the operation of these valves during the actual CD was not fully automatic, but the operator intervened at some instants manually on CV1. Luckily enough, the corresponding opening evolution was recorded (as opposed to the case of the manual intervention on other valves during the same transient – see below), so that we can use this information here, prescribing an adequate (envelope) approximation of the actual evolution as input to the model. (Note that we do not follow all the details /spikes of the actual evolution, because the simplified, lumped parameters model of the heat exchangers neglecting the solids thermal capacity cannot cope with the dynamic response during very fast transients, like a very quick opening and closing of the valve [8].)

The computed evolution of the He temperature at the CSMC inlet ( $T_{in}$ ) and at the CSOM outlet ( $T_{out}$ ) are compared in figure 4 with the measured data.

The discrepancy on  $T_{in}$  between computed and measured is  $\sim 5$  K for the whole transient, whereas  $T_{out}$  is computed within  $\pm 8$  K of the measured value. Considering that the same error bar characterizes the  $T_{out}$  obtained using the measured  $T_{in}$  evolution as boundary condition, see again figure 4, this confirms the accuracy of the refrigerator model. As far as the first phase of the transient is concerned, the experimental  $T_{out}$  suddenly drops of few K in the very first hours, while the computed evolution remains at the initial value until  $\sim 30$  h (close to the heat transit time in the whole magnet). The experimental anticipated decrease can be attributed to the radiative/conductive heat transfer with

the cryostat, providing an additional cooling path not accounted for in the model. This results in an overestimation of the  $T_{out}$  during the first ~50 h.

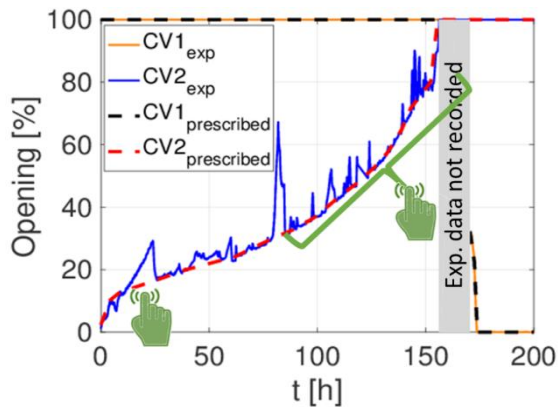

**Figure 3.** Evolution of the opening of the control valves CV1 and CV2, as resulting from a combination of automatic and manual (👉 symbols) controls.

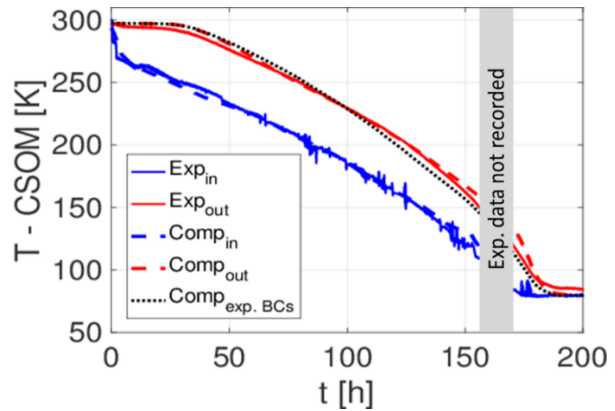

**Figure 4.** Comparison between computed and measured evolution of the He temperature at the inlet of the CSMC and at the outlet of the CSOM. The evolution of the He temperature at the outlet of the CSOM, computed in [14] using experimental boundary conditions at the CSMC boundary instead of the present coupled model, is also shown for reference (dotted line).

The computed evolution of the He  $dm/dt$  at the CSOM inlet is compared in figure 5 with the measured one. The agreement is good, with the measured  $dm/dt$  overestimated by a few g/s (i.e., with an error  $\sim 10\%$ ), until at ~60 h the first manual intervention occurs on the CSOM outlet valve, whose gradually increasing opening, aimed at improving the cooling, was however not recorded. That manual intervention was thus not included in the simulation (where the valve opening is kept constant), so that the computed  $dm/dt$  for  $t > \sim 60$  h underestimates the measured one, until the end of the transient.

The last result of the new coupled model that we present here is the quantity based on which the maximum rate of decrease of  $T_{in}$  is controlled, i.e., the maximum temperature difference across the whole CSMC, see figure 6.

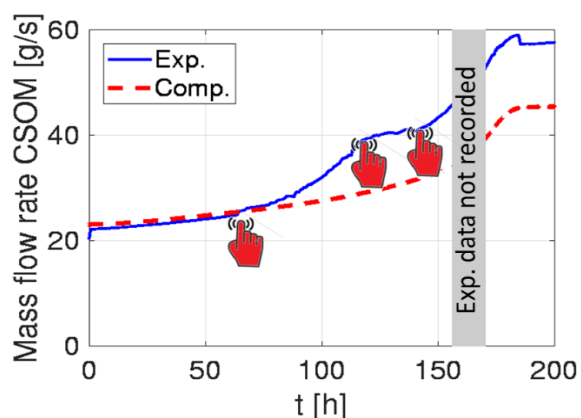

**Figure 5.** Comparison between computed and measured evolution of the He  $dm/dt$  at the inlet of the CSOM. The red symbols (👉) identify the times of manual intervention on the CSOM outlet valve, whose opening was not recorded.

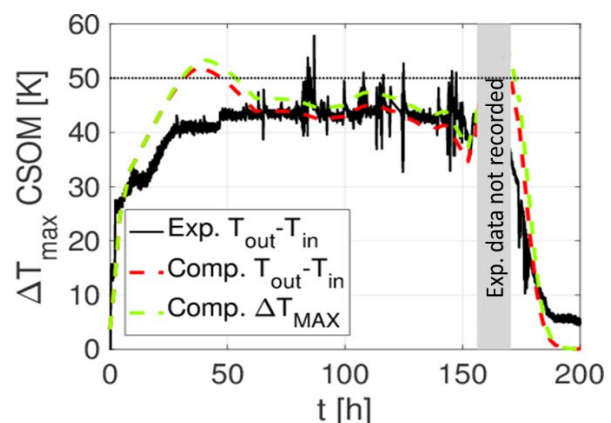

**Figure 6.** Comparison between computed and measured evolution of the maximum temperature difference across the whole CSMC.

It is seen that, whereas there is a good agreement between simulation and measurement in the central part of the transient, there is some discrepancy both at  $t < 50$  h and for  $t > 150$  h. The former should mainly be due to having neglected radiative/conductive heat transfer with the environment, as mentioned above, whereas the discrepancy for  $t > 150$  h should be mainly due to the abovementioned discrepancy in  $dm/dt$ , see figure 5, due in turn to manual interventions not included in the model.

For the very last phase of the transient, i.e.  $t > 180$  h, it is noted that, whereas in the experiment there is always a non-negligible temperature difference across the CSMC, in the simulation this difference disappears. This could be due again to having neglected radiative/conductive heat transfer with the environment, including any background heat load on the CSMC.

#### 4. Conclusions and perspective

A coupled magnet and refrigerator model has been developed inside the 4C code.

The results of a simulation of the ITER CSMC cool-down (CD) from 300 K to 80 K demonstrate the accuracy of the simplified refrigerator model included in the novel coupled model.

In perspective we plan to address the second CD phase, between 80 K and 4 K, validating the model against CSMC data. At that time, the model should be ready to be reliably applied to the development of suitable automatic operation strategies of modern tokamaks, including not only the CD, but also issues like the design of suitable smoothing strategies of the pulsed heat load from the superconducting magnets to the refrigerator.

#### 5. References

- [1] [www.alphysica.com](http://www.alphysica.com)
- [2] <https://supermagnet.sourceforge.io>
- [3] Peng N, Liu L Q, Serio L, Xiong L Y and Zhang L 2009 Thermo-hydraulic analysis of the gradual cool-down to 80 K of the ITER toroidal field coil *Cryogenics* **49** 402-6.
- [4] Maekawa R, Ooba K, Nobutoki M and Mito T 2005 Dynamic simulation of the helium refrigerator/liquefier for LHD *Cryogenics* **45** 199-211.
- [5] Deschildre C, Barraud A, Bonnay P, Briend P, Girard A, Poncet J M, Roussel P and Sequeira S E 2008 Dynamic simulation of an helium refrigerator *Advances in Cryogenic Engineering* **53** 475-82.
- [6] Bradu B, Gayet P and Niculescu S 2009 A process and control simulator for large scale cryogenic plants *Control Engineering Practice* **17** 1388-97.
- [7] Savoldi Richard L, Casella F, Fiori B and Zanino R 2010 The 4C Code for the Cryogenic Circuit Conductor and Coil modeling in ITER *Cryogenics* **50** 167-76.
- [8] Bonifetto R, Kawano K, Savoldi L, Tancredi A and Zanino R 2017 Development and test of a Modelica dynamic model of the ITER CSMC He refrigerator *presented at Cryogenic Engineering Conference* (Madison, USA).
- [9] Bonifetto R, Savoldi L, Tancredi A and Zanino R 2017 Development and test of a dynamic model of the ITER CSMC He refrigerator Part II: from 80 K to 4 K *presented at Chats on Applied Superconductivity* (Sendai, Japan).
- [10] 2009 TF Coils and Structures *ITER Design Description Document*.
- [11] Froio A, Bonifetto R, Carli S, Quartararo A, Savoldi L and Zanino R 2016 Design and optimization of Artificial Neural Networks for the modelling of superconducting magnets operation in tokamak fusion reactors *Journal of Computational Physics* **321** 476-91.
- [12] Tsuji H et al 2001 Progress of the ITER central solenoid model coil program *Nucl. Fusion* **41** 645-51.
- [13] Martovetsky N et al 2016 ITER central solenoid insert test results *IEEE Trans. Appl. Supercond.* **26** 4200605.
- [14] Bonifetto R, Brighenti A, Isono T, Martovetsky N, Kawano K, Savoldi L and Zanino R, 2017 Analysis of the cooldown of the ITER central solenoid model coil and insert coil *Supercond. Sci. Technol* **30** 015015.
- [15] Mattsson S, Elmqvist H and Otter M 1998 Physical systems modeling with Modelica *Control Engineering Practice* **6** 501-10.