

H2S Removal with Sorbent Obtained from Sewage Sludges

Original

H2S Removal with Sorbent Obtained from Sewage Sludges / Papurello, Davide; Lanzini, Andrea; Bressan, Maurizio; Santarelli, Massimo. - In: PROCESSES. - ISSN 2227-9717. - ELETTRONICO. - 8:(2020), pp. 130-141.
[10.3390/pr8020130]

Availability:

This version is available at: 11583/2783472 since: 2020-01-21T14:20:03Z

Publisher:

MDPI

Published

DOI:10.3390/pr8020130

Terms of use:

This article is made available under terms and conditions as specified in the corresponding bibliographic description in the repository

Publisher copyright

(Article begins on next page)

Case Report

H₂S Removal with Sorbent Obtained from Sewage Sludges

Davide Papurello ^{1,2,*}, Andrea Lanzini ^{1,2}, Maurizio Bressan ² and Massimo Santarelli ²

¹ Energy Center, Politecnico di Torino, Via Paolo Borsellino 38/16, 10138 Turin, Italy; andrea.lanzini@polito.it

² Department of Energy (DENERG), Politecnico di Torino, Corso Duca degli Abruzzi, 24, 10129 Turin, Italy; maurizio.bressan@polito.it (M.B.); massimo.santarelli@polito.it (M.S.)

* Correspondence: davide.papurello@polito.it

Received: 20 December 2019; Accepted: 14 January 2020; Published: 21 January 2020

Abstract: Biochar obtained from sewage sludges are adopted for biogas cleaning. Sewage sludges are treated considering temperature, dwell time, activating agent, heating, and flow rate. The best performances achieved are registered considering the char produced at 400 °C using CO₂ as an activating agent with a dwell time of 2 h. The adsorption capacity for the biogas cleaning CH₄/CO₂/H₂S (20 ppm(v)) increased from 1.3 mg/g to 5.9 mg/g with the bed height. Future research with chemical activation processes will be made to improve the adsorption capacity achieved to produce cheaper sorbents than commercial ones.

Keywords: biogas; solid sorbent production; H₂S removal; sewage sludge

1. Introduction

Biogas could be an interesting choice for the sustainable energy generation system [1]. Biogas produced from organic waste treatment, such as from wastewater production sites, contains several trace compounds. Trace compounds detected belong mainly on sulphur, chlorine, aromatic, and terpene compounds [2–4]. Direct and indirect combustion of biogas, as well as its upgrading to biomethane, usually require a gas cleaning section for the sulphur abatement [5–7]. Among several techniques used for sulphur compound removal, such as iron chloride precipitation, metal oxide adsorption, membrane permeation, chemical absorption, and biological methods [1,8,9], adsorption onto activated carbons is considered safe, reliable, efficient and sustainable. Sustainability is a function of the starting material [10,11]. A circular economy is an ever-green approach used for material and energy-saving [12]. Materials from products at the end of their life can be adopted to be reinserted in the biomass cycle [13].

Porosity and surface chemistry, coupled to operating conditions (relative humidity, H₂S concentration, O₂ concentration, presence of other contaminants in biogas stream, and temperature) are the main characteristics that involve the gas cleaning mechanisms [14–22].

In this paper, activated carbons are obtained from the pyrogassification of sewage sludges in a wastewater treatment site. Activated carbons optimal condition are achieved at 400 °C using CO₂ as an activating agent with a dwell time of 2 h. This work would like to prove how the circular economy approach is feasible for biogas cleaning. H₂S is removed with a dependency on adsorption capacity with dwell time and bed length. The main goal of this paper is to design a low cost and low-temperature gas cleaning section.

2. Material Methods

2.1. Char Production Test Bench

Sewage sludges were received from the wastewater treatment plant of Settimo T.se (SMAT spa, Turin, Italy). This sample was obtained using a centrifuge and a drying section to achieve a dry fraction around 95% weight. For the char production used for the gas cleaning purposes, a thermal treatment test bench is needed, see Figure 1. The sewage sludge quantity fixed for each thermal treatment was around 150 ± 5 g. All samples were accomplished in triplicate. The sewage sludge was inserted in a cartridge loaded in the middle of the cylindrical electric oven (500We, C.I.T.T. Italy).

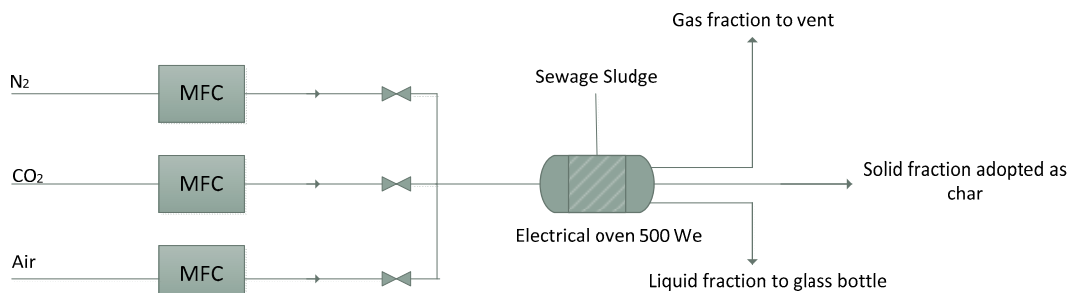

Figure 1. Test rig adopted for the experimental campaign.

The electric power management of the oven has been accomplished using a PID (proportional–integral–derivative controller), Horst temperature regulator model HT MC1 (Lorsch, Germany). The temperature was fixed in an interval range from 200 to 600 °C. These low-temperature values were selected to simulate a direct coupling with SOFC engine gas exhausts, see [10,23,24]. The operating temperature was communicated through a thermocouple (k-thermocouple, Tersid, Milan, Italy). This thermocouple was connected to the regulator and placed to the surface of the tubular reactor inside the oven. The regulator was able to set the desired heating rate and residence time of the process. The gas employed during the physical activation was carbon dioxide (as activating agents). Carbon dioxide was chosen to simulate the coupling between the char production test-rig and SOFCs engine exhausts, mainly composed by carbon dioxide [10,11,24]. The activation step is required to improve the number of active sites. Specific surface and microscopic volume increased, as reported elsewhere [25,26]. Among outputs of physical activation, from temperature higher than 300 °C an oily and a gaseous fraction were generated during the process. The oily fraction was separated and collected in containers through a glass condenser.

2.2. H₂S Adsorption Capacity Test Bench

A biogas mixture was simulated using methane and carbon dioxide. Hydrogen sulphide is added to this mixture considering a cylinder tank of methane with 1000 ppm(v) of H₂S (Praxair Siad, Bergamo, Italy). The chars produced after the thermal activation step were used as sorbent material for the hydrogen sulphide removal. The test bench described below was used to measure the adsorption capacity of such material. All the gas streams were regulated by specific mass flow controllers (MFC), manufactured by Bronkhorst (EL-FLOW, AK Ruurlo, NL). Around 49.5 ± 3.5 g of activated sewage sludge was placed in a glass reactor, tube (25 mm i.d.) with Teflon fittings. The filter had an external diameter of 3 cm, while it was filled up to 10 cm height [27]. At the base of the reactor, a gauze layer was inserted to sustain the filter avoiding issues to the gas analyzer.

H₂S adsorption test was performed in a lab-scale experimental set-up (Figures 2 and 3 and Table 1).

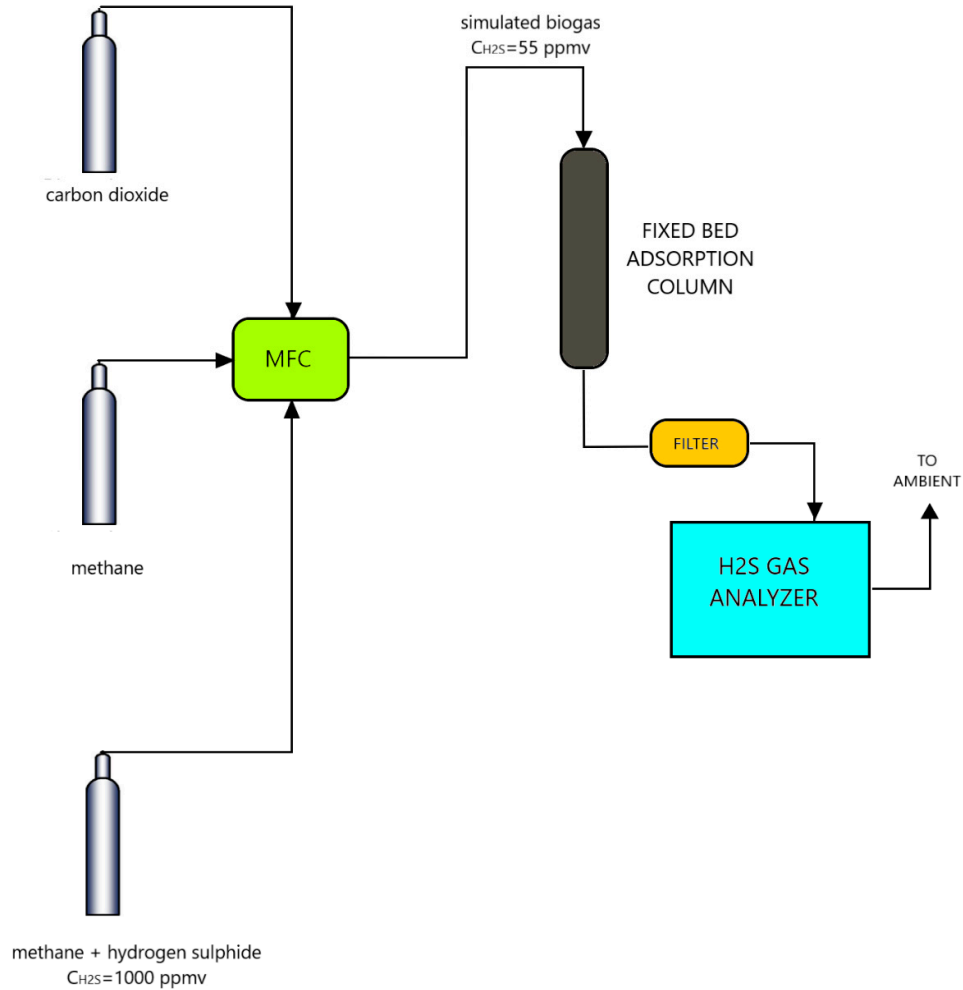

Figure 2. Hydrogen sulphide adsorption experimental set-up.

Table 1. Flow rates used for experimental dynamic adsorption tests.

Carbon Dioxide (NmL/min)	73
Methane (NmL/min)	100
Methane + 1000 ppm(v) H₂S (NmL/min)	10
Total (NmL/min)	183
H₂S Concentration (ppm(v))	55

MECCOS iTR/eTR gas analyser (Siegrist, Karlsruhe, Germany) was used to detect hydrogen sulphide concentration at the outlet of the experimental fixed-bed adsorption column, with output signal obtained by the electrochemical sensor. The sensor could work from 0 to 200 ppm(v). The error of measurement increased linearly from zero to 20 ppm(v) at full scale. The sensor had flow limits between 500 NmL/min and 1000 NmL/min. All the experiments were done considering this flow range. The sensor calibration checked the value of the measured H₂S level, and it was used also to find the signal delay. Air was necessary for sensor cleaning at the end of the tests.

Since large oscillations were shown during the tests, the breakthrough time for adsorption removal capacity calculation was standardly fixed as the time corresponding to the first value of detected concentrations higher than the concentration of breakthrough (Sampling Frequency 1 Hz).

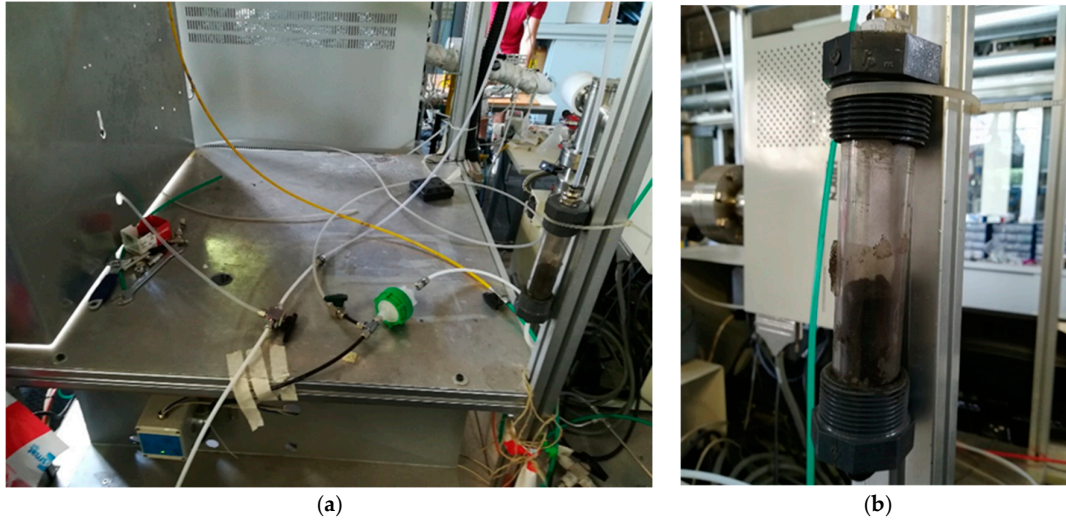

Figure 3. Experimental set-up used in the laboratory. (a) gas cleaning set-up; (b) detail of filter section.

2.3. Adsorption Capacity Calculation

Hydrogen sulphide adsorption capacity (mg/g) was calculated with the following formula:

$$\frac{x}{M} = \frac{Q \cdot MW}{w \cdot V_M} \cdot \left[c_0 \cdot t_s - \int_0^{t_s} c(t) dt \right] \quad (1)$$

where:

- Q = total inlet flow rate (m³/s)
- w = mass charge of the column (g)
- MW = molecular weight of Hydrogen Sulphide (34 g/mol)
- V_M = molar volume (22.4 L/mol)
- c(t) = outlet H₂S concentration (ppm(v))
- c₀ = inlet H₂S concentration (ppm(v))
- t_s = time corresponding to breakthrough concentration (s)

Experiments were repeated twice to verify the results and the reproducibility of the tests.

2.4. Compositional Analysis—Chemical Characterization

Samples were further characterized in terms of chemical composition using energy-dispersive X-ray spectroscopy (EDS, EDX or EDXS). FEI Inspect, (Philips 525 M) coupled with (SW9100 EDAX) was adopted to characterize sorbent samples. This is an analytical technique for the elemental analysis of the sample, which relies on the interaction of some source of X-ray excitation and the considered sample. The chemical composition can be very useful to understand how the surface impregnation affects the adsorption dynamics, the adsorbent interaction with contaminant molecules and the adsorption capacity itself. EDS compositional analysis was performed for S0, ST400_1h_CO₂, ST400_2h_CO₂, ST600_2h_CO₂. To be noticed that S0 means sample as received, while ST400_1h was referred to 400 °C operating temperature, and the reported time was referred to the duration of the activation process with the activating agent (CO₂). It is important to underline a certain irregularity and heterogeneity on the surface, due to the presence of different compounds not well distributed. This has been confirmed by changing the EDS area several times and obtaining different composition results since in some areas deposits of relatively high dimensioned agglomerates were found (Tables 2 and 3). Anyway, the results referred to a mean of three representative areas giving the same global elemental composition (i.e., areas in which carbon-to-oxygen ratio was similar).

Table 2. Energy-dispersive X-ray spectroscopy (EDS) elemental composition.

	%C	%O	Si (mg/g)	Fe (mg/g)	Al (mg/g)	Ca (mg/g)	Mg (mg/g)	S (mg/g)	K (mg/g)
S0	51	42	13	14	10	11	4	7	2
ST400_1h_CO ₂	51	40	25	23	16	19	7	4	3
ST400_2h_CO ₂	34	41	58	82	34	39	14	10	5
ST600_2h_CO ₂	36	37	62	88	37	52	16	9	7

Table 3. Porous structure.

Sample Label	S _{BET} (m ² /g)	S _{t-plot ext} (m ² /g)	V _{pores (d<1.308 nm)} (cm ³ /g)	V _{pores (d<44.9 nm)} (cm ³ /g)	S _{tot,pores} (m ² /g)
S0	0.323	0.377	0.00002	0.00122	0.111
ST400_1h_CO ₂	2.655	3.270	0.00038	0.01386	2.064
ST400_2h_CO ₂	3.289	3.822	0.00024	0.01913	3.485
ST6002hN ₂	4.825	4.901	0.00094	0.04263	3.52

In Table 2 mean values of EDS elemental composition are shown. Despite heterogeneity and uncertainties described before, the main points to be considered are the following:

- Carbon content was reduced when the sample was activated for 2 h with carbon dioxide. This result confirmed doubts on 1 h of activation procedure efficacy and explains worse performance of these samples. The elemental composition of the 1 h activated sample was very similar to the as-received sample.
- The specific content of other elements increased increasing the operating temperature for 2 h.
- Iron content increased more than six times for activated samples. This increase may play a role in hydrogen sulphide removal, as well as the increase in the presence of Calcium. This latter aspect is related to the alkalinity of the sample.

The exhausted sample of ST400_2h_CO₂ after the hydrogen sulphide removal test showed slightly higher concentrations of sulphur compared to the starting sample. This may be an indication of hydrogen sulphide removal through catalytic oxidation and deposition of elemental sulphur.

The samples are mainly mesoporous, while micro-porosity has not been detected (Figure 4). Adsorption/Desorption curves present strong hysteresis and are likely to belong to II-III typology of mesoporous materials with multi-layer adsorption).

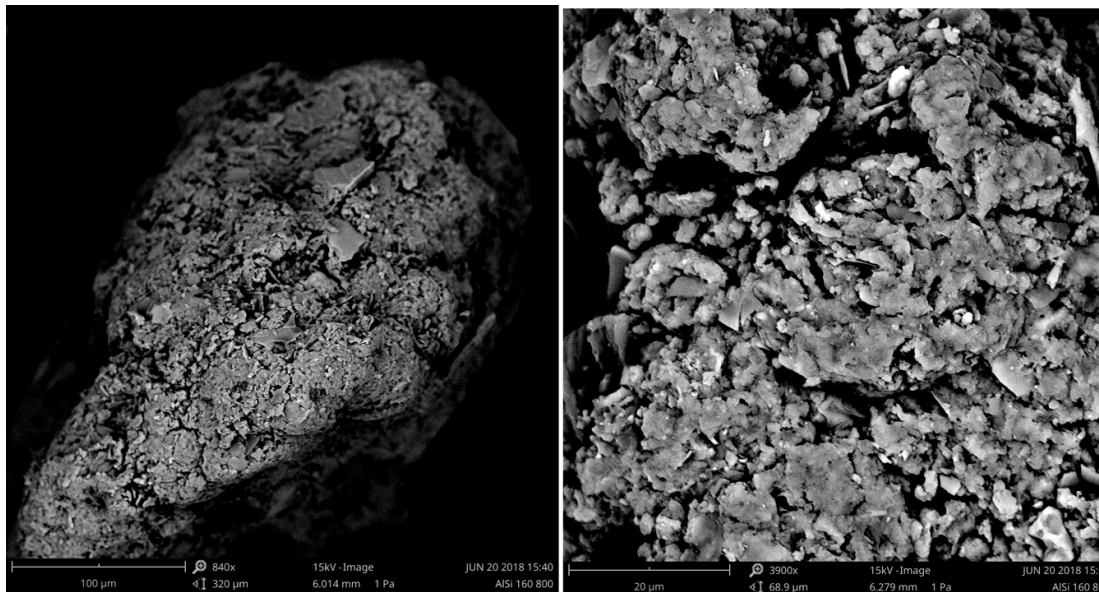
**Figure 4.** ST400_2h_CO₂ SEM Image.

A BET surface area of 3.3 m²/g was detected for ST400_2h_CO₂ sample. This value, even if slightly lower, is comparable with some literature results [28]. In this article, catalytic oxidation is proposed as the prevalent hydrogen sulphide removal phenomenon. This may demonstrate that the physical adsorption on micro-pores with a monolayer could not be the only important phenomenon. In particular Iron content is suitable to demonstrate the chemisorption of hydrogen sulfide through a low porosity gas cleaning filter.

In Figure 5, the mass yield results are reported considering dwell time of 1 and 2 h with activation temperature that ranged from 200 °C to 600 °C. The mass yield passed from roughly 99% to 65% when the temperature passed from 200 °C to 400 °C. The optimal condition was settled to 400 °C and 2 h. This was due to the higher characteristic registered. In Tables 2 and 3 are registered higher specific surface and a higher concentration of alkali metals, such as potassium and alkaline earth metals, such as calcium. These elements, extensively studied in literature are important for the sulphur compounds removal [29,30]. At 600 °C, the activated sample was also tested obtaining better performances, but it was not considered. The main topic in this paper is to design a low cost and low-temperature gas cleaning section; 600 °C is a higher temperature difficult to reach in gas exhausts.

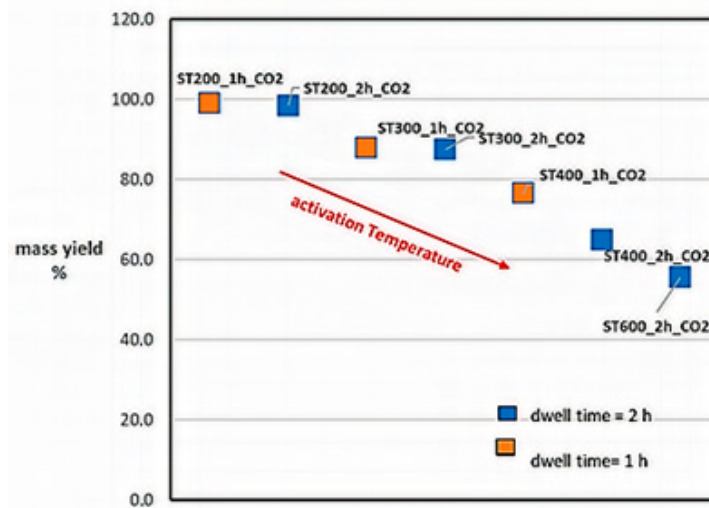

Figure 5. Mass yield vs. activation temperature and dwell time.

3. Results

3.1. Influence of Activation Temperature and Dwell Time on Sulphur Adsorption Capacity

Sulphur adsorption capacity is evaluated using a biogas mixture (CH₄/CO₂ = 1.5) with an H₂S concentration of 20 ppm(v). A treated and as received samples are considered. Dry sewage sludge was also tested as received. Poor performance for this sample is registered. This can be related to the lower specific surface, porosity and elemental composition compared to char activated in temperature (400 °C for more than 1 h).

As described before, different temperatures (200–300–400 °C) and dwell times (1–2 h) were fixed for carbon dioxide activation of the sewage sludge. The bed height is 5 cm. In Figures 6 and 7 breakthrough curves for activated samples with carbon dioxide, with one-hour dwell time at 200–300–400 °C are shown. Higher temperature-activated samples show higher breakthrough times.

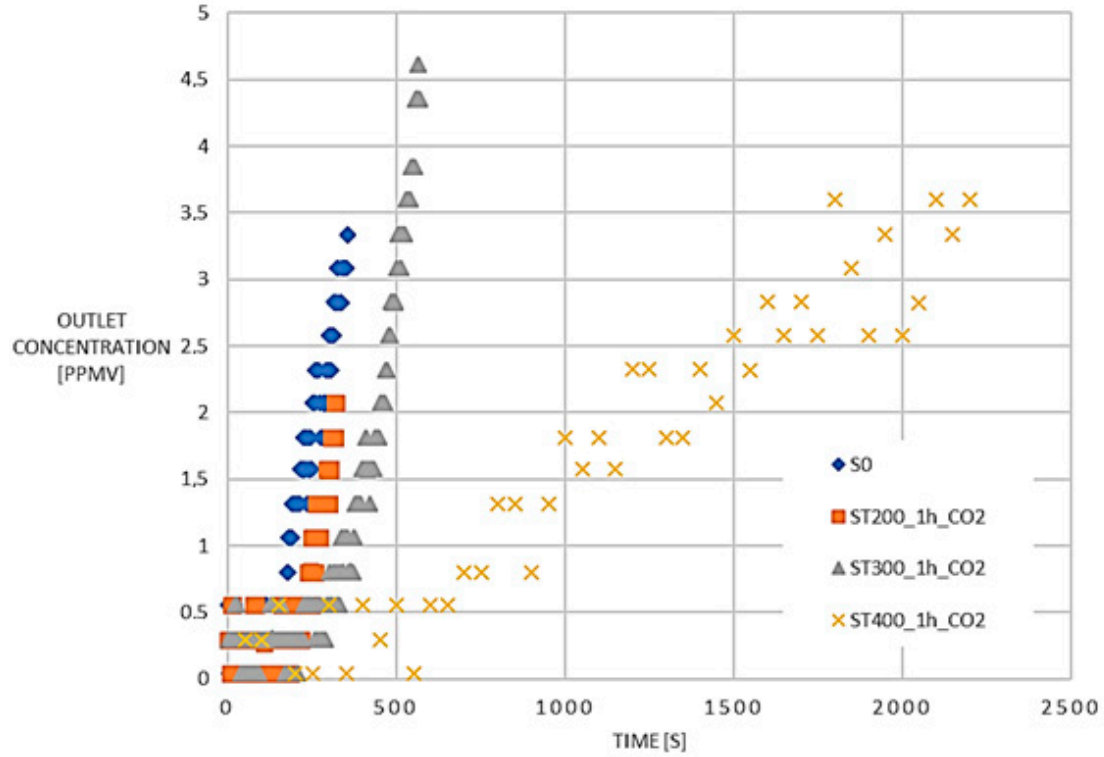

Figure 6. Comparison of the breakthrough curves for carbon dioxide activated samples, dwell time 1 h.

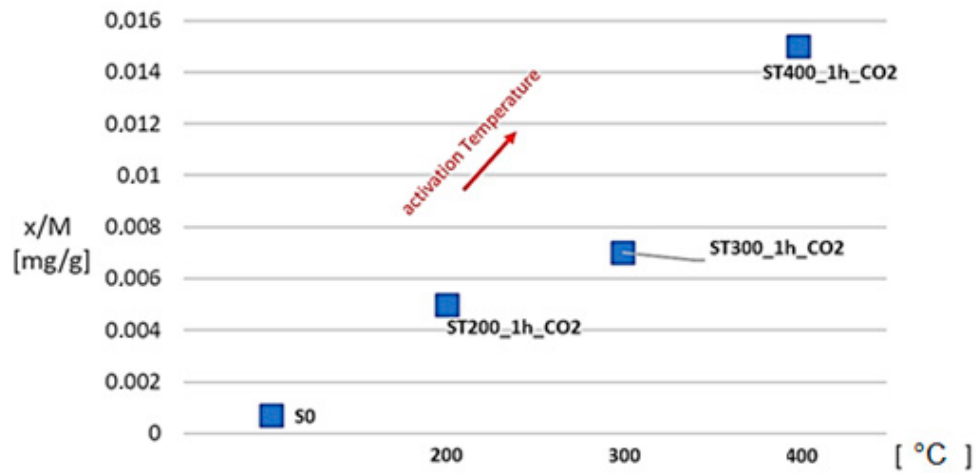

Figure 7. H₂S breakthrough removal capacity results for carbon dioxide activated samples (dwell time = 1 h, breakthrough concentration 1 ppm(v)).

However, very modest removal capacity values were registered even for the 400 °C treated sample. The higher adsorption capacity is registered for this latter value. The activation method was improved increasing the dwell time inside the reactor, from one to two hours. The adsorption capacity increased from 0.015 mg/g to 2.2 mg/g using a longer dwell time, see Figure 8 and Table 4.

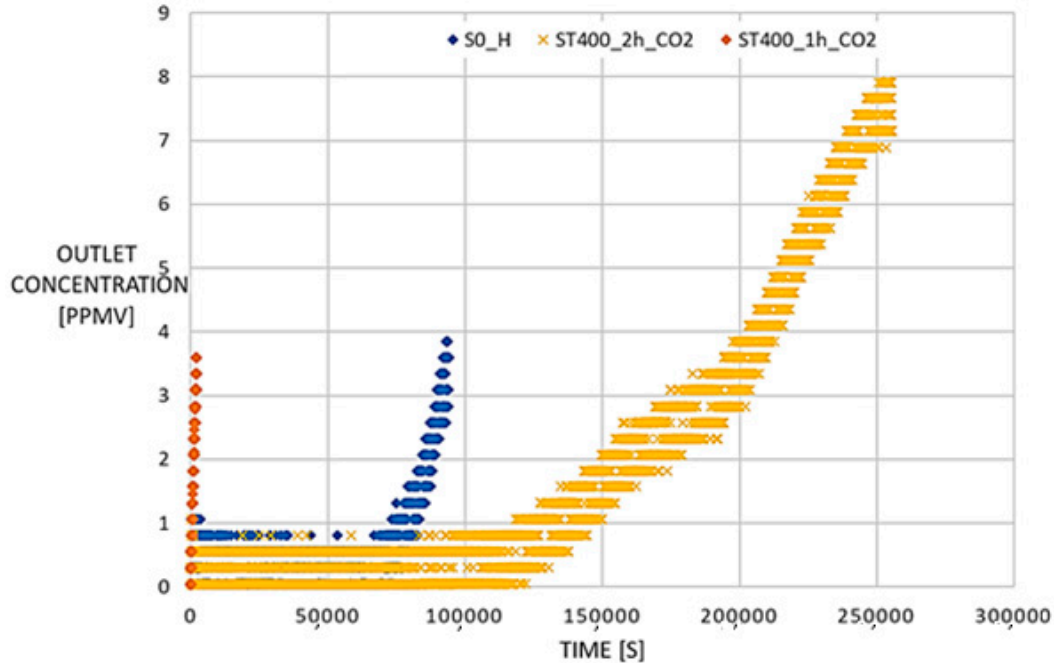

Figure 8. ST400_2h_CO₂ breakthrough curve, the effect of activation dwell time.

It is necessary to observe that this very high improvement in removal performances may be related to the non-optimal conditions of activation (heat losses from the furnace, granulometry, real heating rate transient). These last conditions can affect the sorbent activation, increasing the dwell time there is a reduction of such influence.

3.2. Influence of Bed Height on Sulphur Adsorption Capacity

The as-received sample was tested increasing the filter section length. The improvement on the adsorption capacity value is achieved, as reported in the table below. H₂S removal capacity was also tested for ST400_2h_CO₂ sample to have the confirmation of the positive effect of the length increase. Removal capacities for different bed lengths are shown as follows:

Table 4. Comparison between H₂S removal capacity varying bed length.

	Bed Height (cm)	Mass (g)	x/M (mg/g)	Cbt (ppmv)
s0	5	20	0.0007	1
s0_higher length	8	50	0.0066	1
ST400_1h_CO ₂	5	20	0.015	1
ST400_2h_CO ₂ _a	2.5	10	1.3	3
ST400_2h_CO ₂ _b	5	20	2.2	3
ST400_2h_CO ₂ _c	8	40	5.9	3

The importance of both bed length and activation procedure is shown.

For the activated sample ST400_2h_CO₂ bed height effect was investigated too, with three different configurations (L_t = 2.5 cm, L_t = 5 cm, L_t = 8 cm). A breakthrough concentration of 3 ppm(v) was chosen to compare the results. These results show an increase in the adsorption capacity of almost one order of magnitude compared to the lowest bed length. The maximum adsorption capacity is around 5.9 mg/g for the H₂S removal of 20 ppm(v) in a simulated biogas mixture (Figure 9). This result is due to the specific surface increasing and concentration of alkali and alkaline earth metals, as demonstrated in literature [31–33]. These results highlight how the adsorption capacity is

dependent from the bed height. This capacity being weighted on sorbent loaded in the filter is a specific function. There is no dependency on mass loaded but there is a strong relationship on the aspect ratio of the filter. In fact, as reported elsewhere the ratio between the diameter and the bed length of the filter needs to reach a threshold value.

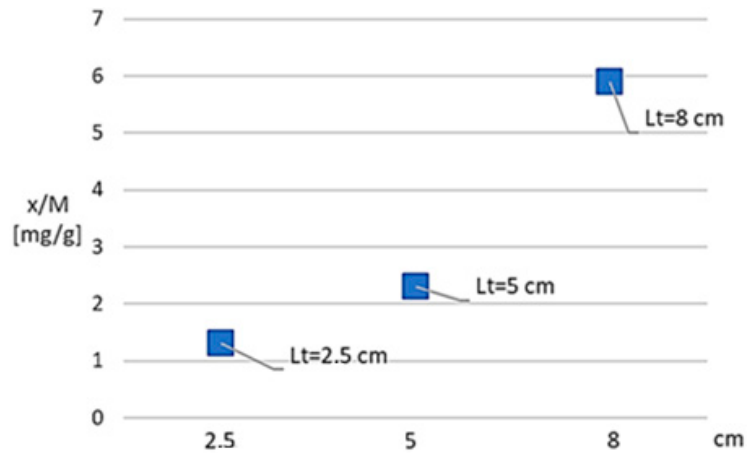

Figure 9. Comparison of x/M results with different bed lengths for the carbon dioxide activated sample ST400_2h_CO₂.

Results reported below (Table 5) show the goodness of repetitions with a deviation of results not higher than 7%.

Table 5. Results from test repetitions and mean value.

Test Number	bt (s)	x/M (mg/g) $\pm \sigma$
1	179,570	2.265 \pm 0.091
2	174,820	2.205 \pm 0.102
3	176,770	2.230 \pm 0.11
mean value	-	2.234 \pm 0.101

4. Conclusions

This study highlighted the potential offered to utilize sewage sludges as precursor materials for adsorbent production. Promising results have been obtained for the hydrogen sulfide adsorption from a simulated biogas stream. It has been demonstrated how the pyrolysis process represents an effective way to valorize a waste into a feedstock for the manufacturing of activated sorbent. The pyrolysis could be considered an encouraging alternative to tackle the urgent issue represented by the sewage sludges disposal [34,35]. Sulphur adsorption capacity achieved from treated sewage sludges at 400 °C with 2 h of dwell time showed interesting results comparable with other solid sorbents. Being a waste, the thermal recovery of such material is interesting. Moreover, the possibility to recover other by-products as bio-fuels from sewage sludge treatments is another interesting topic to be investigated in the future. Solid content is reduced around 60% and the disposal as special waste should further investigate, even if the biogas cleaning is achieved with economic and environmental benefits. Future works also will be related to the chemical impregnation processes to improve chemical properties ensuring chemisorption mechanisms for the sulphur removal. A technical and economic evaluation is needed for optimal low-cost gas cleaning designing.

Author Contributions: Conceptualization and supervision, D.P., A.L., M.B.; Data curation, D.P.; Funding acquisition, M.S., A.L.; Investigation, D.P., A.L.; Methodology, D.P., A.L., M.B., and M.S. All authors have read and agreed to the published version of the manuscript.

Funding: This work is a part of project BIOGAS4ENERGY which is carried out by Politecnico di Torino and other Italian partners (FONDO EUROPEO DI SVILUPPO REGIONALE P.O.R. 2007–2013).

Conflicts of Interest: The authors declare no conflict of interest.

Nomenclature

c(t)	outlet H ₂ S concentration (ppm(v))
c ₀	inlet H ₂ S concentration (ppm(v))
C _{bt}	breakthrough concentration time
EDS	Energy Dispersive X-ray Spectrometry
H ₂ S	Hydrogen Sulphide
S ₀	means sample as received, while ST400_1h is referred to 400 °C operating temperature, and the reported time is referred to the duration of activation process with the activating agent (CO ₂).
MFC	Mass Flow Controller
MW	the molecular weight of Hydrogen Sulphide (34 g/mol)
Q	total inlet flow rate (m ³ /s)
S ₀	sample as received
SOFC	Solid Oxide Fuel Cell
ST xx (400)_t (1h)_(CO ₂)	the sample treated in xx °C (Temperature), for 1 h (time) with carbon dioxide (activating agent)
t _s	a time corresponding to breakthrough concentration (s)
VM	molar volume (22.4 L/mol)
w	a mass charge of the column (g)
We	electrical watt
x/M	adsorption capacity (mg/g)

References

1. Abatzoglou, N.; Boivin, S. A review of biogas purification processes. *Biofuels Bioprod. Biorefin.* **2009**, *6*, 42–71. doi:10.1002/bbb.117.
2. Papurello, D.; Boschetti, A.; Silvestri, S.; Khomenko, I.; Biasioli, F. Real-Time monitoring of removal of trace compounds with PTR-MS: Biochar experimental investigation. *Renew. Energy* **2018**, *125*. doi:10.1016/j.renene.2018.02.122.
3. Rasi, S.; Veijanen, A.; Rintala, J. Trace compounds of biogas from different biogas production plants. *Energy* **2007**, *32*, 1375–1380. doi:10.1016/j.energy.2006.10.018.
4. Rasi, S.; Seppälä, M.; Rintala, J. Organic silicon compounds in biogases produced from grass silage, grass and maize in laboratory batch assays. *Energy* **2013**. doi:10.1016/j.energy.2013.01.015.
5. de Arespacochaga, N.; Valderrama, C.; Mesa, C.; Bouchy, L.; Cortina, J.L. Biogas deep clean-Up based on adsorption technologies for Solid Oxide Fuel Cell applications. *Chem. Eng. J.* **2014**, *255*, 593–603. doi:10.1016/j.cej.2014.06.072.
6. Kuo, J.; Dow, J. Biogas production from anaerobic digestion of food waste and relevant air quality implications. *J. Air Waste Manag. Assoc.* **2017**, *67*, 1000–1011. doi:10.1080/10962247.2017.1316326.
7. Kupecki, J.; Papurello, D.; Lanzini, A.; Naumovich, Y.; Motylinski, K.; Blesznowski, M.; Santarelli, M. Numerical model of planar anode supported solid oxide fuel cell fed with fuel containing H₂S operated in direct internal reforming mode (DIR-SOFC). *Appl. Energy* **2018**, *230*, 1573–1584. doi:10.1016/j.apenergy.2018.09.092.
8. Awe, O.W.; Zhao, Y.; Nzihou, A.; Minh, D.P.; Lyczko, N. A Review of Biogas Utilisation, Purification and Upgrading Technologies. *Waste Biomass Valoriz.* **2017**. doi:10.1007/s12649-016-9826-4.
9. Ryckebosch, E.; Drouillon, M.; Vervaeren, H. Techniques for transformation of biogas to biomethane. *Biomass Bioenergy* **2011**, *35*, 1633–1645. doi:10.1016/j.biombioe.2011.02.033.
10. Santarelli, M.; Briesemeister, L.; Gandiglio, M.; Herrmann, S.; Kuczynski, P.; Kupecki, J.; Vega, L.F. Carbon recovery and re-Utilization (CRR) from the exhaust of a solid oxide fuel cell (SOFC): Analysis through a proof-Of-Concept. *J. CO₂ Util.* **2017**, *18*. doi:10.1016/j.jcou.2017.01.014.

11. Bona, D.; Papurello, D.; Flaim, G.; Cerasino, L.; Biasioli, F.; Silvestri, S. Management of Digestate and Exhausts from Solid Oxide Fuel Cells Produced in the Dry Anaerobic Digestion Pilot Plant: Microalgae Cultivation Approach. *Waste Biomass Valoriz.* **2020**, *1*–16. doi:10.1007/s12649-019-00931-3.
12. Kacprzak, M.; Neczaj, E.; Fijałkowski, K.; Grobelak, A.; Grosser, A.; Worwag, M.; Rorat, A.; Almás, Á.R.; Singh, B.R.; Brattebø, H. Sewage sludge disposal strategies for sustainable development. *Environ. Res.* **2017**, *156*, 39–46. doi:10.1016/j.envres.2017.03.010.
13. Geissdoerfer, M.; Savaget, P.; Bocken, N.M.P.; Hultink, E.J. The Circular Economy-A new sustainability paradigm? *J. Clean. Prod.* **2017**, *143*, 757–768. doi:10.1016/j.jclepro.2016.12.048.
14. Papurello, D.; Lanzini, A.; Ferrero, D.; Smeacetto, F.; Leone, P.; Biasioli, F.; Santarelli, M. Covapors influence on activated carbon filter performance removal from a biogenous fuel suitable for SOFC application using a rapid and online tool. In Proceedings of the 5th European Fuel Cell Piero Lunghi Conference, Rome, Italy, 11–13 December 2013.
15. Papurello, D.; Tomasi, L.; Silvestri, S.; Santarelli, M. Evaluation of the Wheeler-Jonas parameters for biogas trace compounds removal with activated carbons. *Fuel Process. Technol.* **2016**, *152*, 93–101. doi:10.1016/j.fuproc.2016.06.006.
16. Seredych, M.; Bandosz, T.J. Desulfurization of Digester Gas on Catalytic Carbonaceous Adsorbents: Complexity of Interactions between the Surface and Components of the Gaseous Mixture. *Ind. Eng. Chem. Res.* **2006**, *45*, 3658–3665. doi:10.1021/ie051388f.
17. Wood, G.O. A review of the effects of covapors on adsorption rate coefficients of organic vapors adsorbed onto activated carbon from flowing gases. *Carbon* **2002**, *40*, 685–694. doi:10.1016/S0008-6223(01)00185-3.
18. Wood, G.O.; Snyder, J.L. Estimating service lives of organic vapor cartridges III: multiple vapors at all humidities. *J. Occup. Environ. Hyg.* **2007**, *4*, 363–374. doi:10.1080/15459620701277468.
19. Papurello, D.; Gandiglio, M.; Kafashan, J.; Lanzini, A. Biogas Purification: A Comparison of Adsorption Wood-Derived Char Using Isotherm Equations. *Processes* **2019**, *7*, 774. doi:10.3390/pr7100774.
20. Peluso, A.; Gargiulo, N.; Aprea, P.; Pepe, F.; Caputo, D. Nanoporous Materials as H₂S Adsorbents for Biogas Purification: A Review. *Sep. Purif. Rev.* **2019**, *48*, 78–89. doi:10.1080/15422119.2018.1476978.
21. Rahman, A.; Habib, S.; Rahman, M.; Sajib, M.S.J.; Yousuf, A. A novel multi-Phase treatment scheme for odorous rubber effluent. *Environ. Technol. (U.K.)* **2019**, *0*, 1–7. doi:10.1080/09593330.2019.1668965.
22. Surra, E.; Costa Nogueira, M.; Bernardo, M.; Lapa, N.; Esteves, I.; Fonseca, I. New adsorbents from maize cob wastes and anaerobic digestate for H₂S removal from biogas. *Waste Manag.* **2019**, *94*, 136–145. doi:10.1016/j.wasman.2019.05.048.
23. Papurello, D.; Lanzini, A.; Tognana, L.; Silvestri, S.; Santarelli, M. Waste to energy: Exploitation of biogas from organic waste in a 500 W solid oxide fuel cell (SOFC) stack. *Energy* **2015**, *85*, 145–158. doi:10.1016/j.energy.2015.03.093.
24. Papurello, D.; Silvestri, S.; Tomasi, L.; Belcari, I.; Biasioli, F.; Santarelli, M. Biowaste for SOFCs. *Energy Procedia* **2016**, *101*, 424–431. doi:10.1016/j.egypro.2016.11.054.
25. Coppola, G.; Papurello, D. Biogas Cleaning: Activated Carbon Regeneration for H₂S Removal. *Clean Technol.* **2018**, *1*, 40–57. doi:10.3390/cleantechnol1010004.
26. Papurello, D.; Santarelli, M.; Fiorilli, S. Physical Activation of Waste-Derived Materials for Biogas Cleaning. *Energies* **2018**, *11*, 2338. doi:10.3390/en11092338.
27. Gabelman, A. Adsorption Basics: Part 1. *Am. Inst. Chem. Eng. (AIChE)* **2017**, *113*, 48–53.
28. Yuan, W.; Bandosz, T.J. Removal of hydrogen sulfide from biogas on sludge-Derived adsorbents. *Fuel* **2007**, *86*, 2736–2746. doi:10.1016/j.fuel.2007.03.012.
29. Marchelli, F.; Cordioli, E.; Patuzzi, F.; Sisani, E.; Barelli, L.; Baratieri, M.; Arato, E.; Bosio, B. Biomass and Bioenergy Experimental study on H₂S adsorption on gasification char under different operative conditions. *Biomass Bioenergy* **2019**, 106–116. doi:10.1016/j.biombioe.2019.05.003.
30. Papurello, D.; Tomasi, L.; Silvestri, S.; Belcari, I.; Santarelli, M.; Smeacetto, F.; Biasioli, F. Biogas trace compound removal with ashes using proton transfer reaction time-of-flight mass spectrometry as innovative detection tool. *Fuel Process. Technol.* **2016**, *145*, 62–75. doi:10.1016/j.fuproc.2016.01.028.
31. Finocchio, E.; Montanari, T.; Garuti, G.; Pistarino, C.; Federici, F.; Cugino, M.; Busca, G. Purification of biogases from siloxanes by adsorption: On the regenerability of activated carbon sorbents. *Energy Fuels* **2009**. doi:10.1021/ef900356n.
32. Lombardi, L.; Costa, G.; Spagnuolo, R. Accelerated carbonation of wood combustion ash for CO₂ removal from gaseous streams and storage in solid form. *Environ. Sci. Pollut. Res.* **2018**, *25*, 1–11.

33. Wu, H.; Zhu, Y.; Bian, S.; Ko, J.H.; Li, S.; Xu, Q. H₂S adsorption by municipal solid waste incineration (MSWI) fly ash with heavy metals immobilization. *Chemosphere* **2018**, *195*, 40–47. doi:10.1016/j.chemosphere.2017.12.068.
34. Andersen, A. *Disposal and Recycling Routes for Sewage Sludge Part 1-Sludge Use Acceptance Report*; European Communities: Luxembourg, 2001; ISBN 92-894-1798-6.
35. Bonfiglioli, L.; Bianchini, A.; Pellegrini, M.; Saccani, C. *Sewage Sludge: Characteristics and Recovery Options*; Università di Bologna: Bologna, Italy, 2017.



© 2020 by the authors. Licensee MDPI, Basel, Switzerland. This article is an open access article distributed under the terms and conditions of the Creative Commons Attribution (CC BY) license (<http://creativecommons.org/licenses/by/4.0/>).