

Controlling perfluoropolyalkylether rearrangements at the surface of photocured networks

Original

Controlling perfluoropolyalkylether rearrangements at the surface of photocured networks / Trusiano, Giuseppe; Vitale, Alessandra; Rizzello, Melania; Bonneaud, Céline; Joly-Duhamel, Christine; Friesen, Chadron M.; Bongiovanni, ROBERTA MARIA. - In: EUROPEAN POLYMER JOURNAL. - ISSN 0014-3057. - ELETTRONICO. - 121:109285(2019), pp. 1-9. [10.1016/j.eurpolymj.2019.109285]

Availability:

This version is available at: 11583/2761852 since: 2019-10-21T09:49:50Z

Publisher:

Elsevier

Published

DOI:10.1016/j.eurpolymj.2019.109285

Terms of use:

This article is made available under terms and conditions as specified in the corresponding bibliographic description in the repository

Publisher copyright

Elsevier postprint/Author's Accepted Manuscript

© 2019. This manuscript version is made available under the CC-BY-NC-ND 4.0 license
<http://creativecommons.org/licenses/by-nc-nd/4.0/>. The final authenticated version is available online at:
<http://dx.doi.org/10.1016/j.eurpolymj.2019.109285>

(Article begins on next page)

Controlling perfluoropolyalkylether rearrangements at the surface of photocured networks

Giuseppe Trusiano,^{†,} Alessandra Vitale,^{†,*} Melania Rizzello,[†] Céline Bonneaud,[‡] Christine Joly-Duhamel,[‡] Chadron M. Friesen,[§] Roberta Bongiovanni[†]*

[†] Politecnico di Torino, Department of Applied Science and Technology, Corso Duca degli
Abruzzi 24, 10129, Torino, Italy

[‡] Ecole Nationale Supérieure de Chimie de Montpellier, Institut Charles Gerhardt, UMR5253-
CNRS, 8 Rue de l'Ecole Normale, 34296 Montpellier Cedex 5, France

[§] Trinity Western University, Department of Chemistry, 7600 Glover Road, V2Y 1Y1, Langley
BC, Canada

KEYWORDS: Surface rearrangements; Perfluoropolyalkylethers; UV-curing; Wettability
control; Hydrophobic polymers.

ABSTRACT

Perfluoropolyalkylether (PFPAE) reactive macromers can be used in very low concentration (≤ 2 wt.%) as efficient surface modifying agents of epoxy resins to obtain hydrophobic photocured copolymers. However, the hydrophobicity achieved thanks to the spontaneous migration of the PFPAE chains to the free surface could be dramatically lost due to environmentally induced rearrangements of the fluorinated segments, even though they are chemically bonded to the polymer matrix. To preserve the coating performances of the photocured copolymers when exposed to various environments, different approaches have been investigated. In particular, to hinder the mobility of the fluorinated chains, the length of the fluorinated comonomer chain, the epoxy matrix stiffness, and the functional PFPAE end-groups have been tuned. Such strategies are demonstrated to inhibit or completely suppress the surface reconstruction of the copolymers when exposed to different surrounding environments (e.g., immersion in water or oil), allowing to obtain photocured films with a long-term and constant reduced surface energy of ≈ 20 mN/m.

INTRODUCTION

The performance of polymeric materials in many application fields relies on their surface properties, including wettability, adhesion, friction, paintability, hardness, appearance (e.g., gloss) and biocompatibility.[1] The control of the surface composition and structure of the materials, and their interaction with the environment are thus essential for developing high-performance polymers. In order to impart the desired surface properties to polymeric films, an extensively applied strategy is the introduction of a small amount of specific low surface energy

additives that are able to spontaneously locate preferentially at the air/polymer interface, self-segregating towards the less polar surface during film formation.[2–5] This strategy has also been demonstrated to be successful for controlling the surface of polymers cured by photoinduced reactions.[6–9] Radiation curing is very interesting as, when multifunctional monomers are used, it provides a facile and rapid method for the synthesis of crosslinked polymer networks at room temperature, without solvents, and within very short conversion times. As a matter of fact, by the addition of a reactive additive characterized by a low surface energy (generally fluorinated or siloxane monomers) to a photocurable formulation, the migration of the modifier to the free surface can occur in order to thermodynamically minimize the total energy of the system. This leads to a spontaneous surface enrichment of the low surface energy component, which becomes chemically bonded to the polymer matrix after photo-induced polymerization and crosslinking, avoiding the issues of possible leaching or depletion of the additive. The spontaneous surface segregation of low surface energy comonomers can thus be exploited to produce well-controlled copolymer surfaces in a reliable, low-cost and easy way, giving rise to materials characterized by improved hydrophobicity, adhesive, easy-to-clean and antifouling properties.[10–13]

Perfluoropolyalkylethers (PFPAEs) with specific photoreactive end-groups are attractive low surface energy components to modify the surface properties of photocured polymers via the spontaneous surface segregation approach.[7,14–16] PFPAEs are based on structural units such as $-(CF_2O)-$, $-(CF_2CF_2O)-$, $-(CF_2CF_2CF_2O)-$ and $-(CF(CF_3)CF_2O)-$, and CF_3O- , C_2F_5O- , C_3F_7O- and $COFC_2F_4-$ as terminal groups, depending on the synthesis route.[17] They represent a special class of fluoropolymers with outstanding properties: low glass transition temperature, high chemical and thermal inertness, low surface energy and refractive index, low adhesion and

friction, excellent ageing and flame resistance, good protection against corrosion, environmental pollution, weather aggression and graffiti.[14,18–21] Interestingly, PFPAEs can be used as non-toxic alternative to the long perfluoroalkyl chains presently banned in many countries.[22,23] In a recent work,[24] the authors have demonstrated that a low amount (i.e., 2 wt.%) of PFPAE macromers can be introduced in UV-curable epoxy systems to selectively modify the copolymer surface. In this way, hydrophobic photocured copolymers with a surface energy as low as 17 mN/m can be obtained by exploiting the spontaneous surface segregation of the fluorinated comonomer.[25]

However, polymer surfaces are known to be quite dynamic and can rapidly rearrange or exchange with the bulk components upon contact with a different surrounding environment; this phenomenon is especially evident with PFPAE systems, due to their high chain mobility. Such environmentally induced reorganization of chain segments occurs to minimize the interfacial free energy: the tendency is the exposure of hydrophobic moieties to a non-polar environment (e.g., air) and hydrophilic moieties to a polar environment (e.g., water). The surface rearrangement of polymer films has been investigated for different systems,[26–32] and is an important factor in reduced material performance as it may lead to substantial changes in its properties. Maintaining long-term low surface energy in the film, thus preventing the reconstruction of the surface, is critical when designing surface polymers for practical application. Considering that polymeric films are very often in contact with polluted air or liquids (e.g., for biomedical applications and coatings for outdoor), it may be critical to control the surface rearrangements and to know how reliable a material is concerning its surface functionality, upon routine handling.

The aim of this work is to control the environmentally induced rearrangements of PFPAE chains in a photocured epoxy matrix, in order to produce copolymers showing stable hydrophobic

surfaces. The wetting behavior (evaluated by contact angle measurements) and the surface morphology and phase-separation (investigated by atomic force microscopy) of copolymer systems, when exposed to a polar or a non-polar liquid, can be tuned following different approaches, which allow to control the fluorinated dangling chains reorganization on the surface. A first strategy focuses on the modification of the stiffness of the PFPAE additive and of the epoxydic matrix, in terms of length of the fluorinated chain and matrix glass transition temperature. Another method is based on the modification of the PFPAE comonomer functionality. In fact, through an appropriate choice of their functional end-group, the fluorinated comonomers can interact in different ways with the epoxy resin when the photoinduced cationic polymerization occurs, resulting in different packing structures and thus different fluorinated chains distances within the photocured network.[33] Applying one of these strategies, the environmentally induced surface rearrangements are well-controlled, allowing to obtain photocured films with low and constant surface energy (≈ 20 mN/m), when exposed to air, water or oil.

MATERIALS AND METHODS

Synthesis of the fluorinated alcohols and epoxide

Materials

The oligo(HFPO) acyl fluoride was synthesized using cesium fluoride (from Sigma Aldrich, Canada) as initiator, tetraethylene glycol dimethyl ether (from Sigma Aldrich, Canada) and HFE 7100 (from 3M™ Novec™, USA) as solvents, and hexafluoropropylene oxide (generously supplied by Chemours™, USA) as monomer.

Epibromohydrin, potassium *tert*-butoxide (*t*-BuOK), *tert*-butanol (*t*-BuOH) and all other chemicals were purchased from Sigma Aldrich (Canada).

Procedure

The higher molecular weight oligo(HFPO) methylene alcohol (HFPO₁₀-MA) was kindly provided by E. I. du Pont de Nemours and Company (USA).

The lower molecular weight oligo(HFPO) methylene alcohols (HFPO₅-MA) was synthesized as described in a recent work,[24] according to a modified procedure previously reported.¹⁹[34]

Scheme 1. Scheme of the epoxidation reaction of oligo(HFPO) methylene alcohol HFPO₁₀-MA, leading to HFPO₁₀-MEpo monomer.

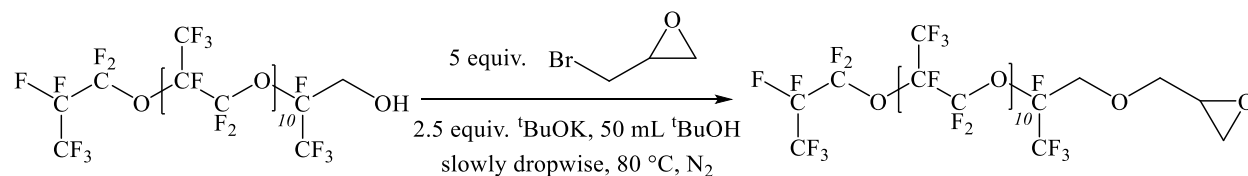

The fluorinated monoepoxy monomer HFPO₁₀-MEpo was synthesized starting from the PFP AE monoalcohol by an epoxidation reaction, as reported in Scheme 1, adapting a previously published synthetic route.[35] HFPO₁₀-MA, $M_n = 2200$ g/mol (22 g, 10 mmol), and epibromohydrin (0.685 g, 5 mmol, 5 equiv.) were added to a 500 mL 3-necked round-bottomed flask. A solution of *t*-BuOK (2.804 g, 25 mmol, 2.5 equiv.) and *t*-BuOH (50 mL) was introduced into an addition funnel and added dropwise at 80 °C to the HFPO₁₀-MA/epibromohydrin mixture under continuous stirring. The reaction was followed by gas chromatography–mass spectrometry (GC–MS) by checking the conversion of the alcohol fragment ($m/z = 131$ g/mol ⁺CF(CF₃)CH₂OH) into the corresponding epoxide ($m/z = 57$ g/mol ⁺CH₂(O)CH). The reaction was complete after 30 minutes. Then, the mixture was cooled down to room temperature and the

fluorinated phase was washed with water and acetone. The mixture was dissolved in HFE 7100, dried over MgSO₄, filtrated and concentrated under vacuum, collecting a clear orange oil, which was purified by flash chromatography (from 10:90 to 80:20 ethyl acetate:pentane) obtaining a 30% isolated yield of the pure product. The structure of the PFP AE monomer was confirmed by nuclear magnetic resonance (NMR), GC–MS, and matrix assisted laser desorption ionization time-of-flight mass spectrometry (MALDI–TOF–MS) (see Supporting Information, Figure S1-S7).

¹H-NMR (400 MHz, benzene-*d*₆ capillary, 25 °C) δ = 4.07 (*t*, -CF(CF₃)-CH_aH_bO-, 1H), 3.95 (*m*, -CF(CF₃)-CH_aH_bO-, 1H), 3.77 (*d*, -CH_cH_dCH(O)CH₂-, 1H), 3.28 (*q*, -CH_cH_dCH(O)CH₂, 1H), 2.91 (*s*, -CH_e(O)CH₂, 1H), 2.53 (*t*, -CH(O)CH_fH_g, 1H), 2.35 (*s*, -CH(O)CH_fH_g, 1H).

¹³C-NMR (101 MHz, benzene-*d*₆, 25 °C) δ = 122.11-101.00 (*m*, -CF₃ and CF₂ of repeat unit), 72.70 (*s*, -CH₂CH(O)CH₂), 67.91 (*d*, -CF(CF₃)CH₂OCH₂CH(O)CH₂), 49.35 (*s*, -CH₂CH(O)CH₂), 41.66 (*s*, -CH₂CH(O)CH₂).

¹⁹F-NMR (376.5 MHz, benzene-*d*₆, 25 °C) δ = -146.16 (*q*, CF(CF₃) of repeat unit), -134.95 (*m*, ω CF(CF₃)), -131.68 (*s*, α CF₂), -86.66 to -80.98 (CF₃ and CF₂ of repeat unit).

GC–MS (EI) fragmentation: m/z = CH₂OH⁺ (31 m/z), CH₂(O)CH⁺ (57 m/z), CF₃⁺ (69 m/z), C₂F₄⁺ (100 m/z), C₂F₅⁺ (119 m/z), C₂F₄CH₂OH⁺ (131 m/z), C₃F₅O⁺ (147 m/z), C₃F₆⁺ (150 m/z), CH₂CHOCH₂CF(CF₃)⁺ (157 m/z), C₃F₇⁺ (169 m/z).

Photoinduced polymerization

Materials

The epoxy resins used in this work were 1,6-hexanediol diglycidyl ether (HDGE, Grilonit[®] RV 1812 by EMS, Switzerland) and 3,4-epoxycyclohexylmethyl 3,4-epoxycyclohexanecarboxylate (CE, by Sigma-Aldrich, Italy).

A series of blends were prepared by addition to the HDGE resin of PFP AE alcohols, HFPO_n-MA (n = 5 and 10), and PFP AE epoxide, HFPO₁₀-MEpo, synthesized on purpose for the work as reported above. The fluorinated alcohol with higher molecular weight (i.e., HFPO₁₀-MA) was also added to a 1:1 HDGE:CE blend (expressed in weight fraction).

Triphenylsulfonium hexafluoroantimonate salts, 50 wt% in propylene carbonate, purchased from Sigma Aldrich (Italy), was used as cationic photoinitiator.

Procedure

Photocurable formulations were prepared by adding to a diepoxide resin (i.e., HDGE monomer or 1:1 HDGE:CE blend) 2 wt% of a fluorinated additive (i.e., HFPO₁₀-MA, HFPO₅-MA or HFPO₁₀-MEpo) and 2 wt% of the photoinitiator. The UV-sensitive mixtures were coated onto a glass substrate, using a wire-wound applicator, and then irradiated by means of a high-pressure mercury arc lamp Dymax ECE, using a light intensity of 150 mW/cm² for 5 minutes. Samples with different thickness, going from 100 μm to 300 μm, were prepared.

After irradiation, the samples were stored for at least 24 h at room temperature before properties evaluation, to allow a complete dark postcuring reaction, typical of cationic process.

Polymer characterization

Static contact angle measurements were performed with a FTA 1000C instrument, equipped with a video camera and image analyzer, at room temperature with the sessile drop technique. Three

to five measurements were performed on each sample and the values averaged. The probe liquids were water and hexadecane, whose surface tension are 72.1 mN/m and 28.1 mN/m, respectively. The photocured copolymeric films prepared on glass substrates were immersed in a liquid (water or hexadecane) for a specific period of time. Then the surface of the film was carefully cleaned using a soft tissue to remove the excess of liquid and gently blown by an air flow to avoid contamination from the paper. Immediately after, the contact angle was measured; therefore, values were recorded after different immersion periods. The immersion tests were stopped when a steady minimum contact angle value was attained. After it, the films were exposed to air at room temperature (RT) to dry and the contact angles were again periodically measured until a constant value was reached. Also for the wettability study after immersion, three to five measurements were performed on each sample: the mean value and the error were determined. The surface energy was calculated by the Owens-Wendt geometric mean method.[36]

Differential scanning calorimetry (DSC) thermograms were recorded using a Mettler Toledo DSC1 STARe System in the temperatures ranging from $-60\text{ }^{\circ}\text{C}$ to $150\text{ }^{\circ}\text{C}$ using a heat/cool/heat method at a heating and cooling scanning rate of $10\text{ }^{\circ}\text{C}/\text{min}$, under nitrogen flux. The glass transition temperature (T_g) was determined using the midpoint of the heat capacity jump on the second heating cycle thermogram.

Atomic force microscopy (AFM) experiments were performed using a Bruker Innova instrument. Film surface morphology and surface phase images were collected in tapping mode with RTESPA-300 (Bruker) probes. Data treatment and presentation were realized with the help of Gwyddion Software. Root-mean-squared surface roughness (S_q) was evaluated from AFM surface morphology images with scan sizes of $5 \times 5\text{ }\mu\text{m}^2$; the average domains size was

evaluated from AFM surface phase images with scan sizes of $5 \times 5 \mu\text{m}^2$. For each sample at least three scans were made on different parts of the films.

In order to study the change in morphology of the copolymers in the presence of water, the photocured films were immersed in water for 24 h at RT, then their surface was carefully dried with a soft tissue and a gentle air flow, and AFM analyses were performed immediately after.

RESULTS AND DISCUSSION

It is well-known that the incorporation of fluorinated additives to a polymer makes its surface energy γ significantly low, leading to lower wettability and poorer adhesion properties. In a previous work [24] on photocured epoxy polymers based on HDGE, we have demonstrated how the addition of a low amount of a PFPAE comonomer can significantly decrease the wettability of the system. The surface energy was in fact found to be reduced from 42 to 17 mN/m by addition of a PFPAE monofunctional alcohol, which was covalently linked to the epoxy matrix by chain transfer reaction.[25,37] These results suggest the presence of fluorinated chains at the free surface, in agreement with a spontaneous surface segregation of the lower surface energy component, which has migrated towards the less polar surface (i.e., the one exposed to air).[7,8,24]

The surface segregation of the PFPAE additive was confirmed by chemical composition analysis, in particular FT-IR ATR and XPS, as reported in [24],[38], and [39]. In a HDGE + 2 wt% HFPO10-MA film, the theoretical F concentration should be 1.4 wt%, while a concentration of 64.5 wt% was detected on the air surface. This result indicates that most of the fluorinated comonomer is located in the outermost layer of the crosslinked network. [24]

However, because of the high mobility of the PFPAE chains (which show a $T_g < -50\text{ }^\circ\text{C}$) and the absence of crystallinity of the matrix, surface rearrangements of polymer chains occur. In fact, although the polymer film is formed by a crosslinked network, free volume and chain dynamics can allow a polymer reconstruction at the surface.[37] Water-induced surface rearrangements have been previously reported for several other polymeric systems.[31,40,41] These rearrangements can occur very rapidly and have been attributed to different phenomena: hydration and swelling, resulting in the emergence of a swollen layer at the surface, or re-orientation of the polymer segments, backbone, or pendant groups.[42,43] These surface rearrangements clearly take place in the photocured HDGE + 2wt% HFPO₁₀-MA systems, as shown in Figure 1. When the copolymeric film is kept in contact with water, the hydrophobicity strongly decreases, almost reaching the contact angle value of the neat epoxy resin (i.e., $\theta = 64^\circ$). Due to the movements of the fluorinated chains towards the bulk of the polymer film, polar segments and groups are left in contact with the polar liquid, causing a drop off in hydrophobicity of the cured film. Also when the fluorinated cured copolymer is subjected to a non-polar liquid (in this work hexadecane) a notable decrease of the hydrophobicity can be observed (Figure 1). Also in this case, the water contact angle values of HDGE + 2 wt% HFPO₁₀-MA system, after 48 h of immersion, become very close to those owned by the neat epoxydic matrix without fluorine. Thus, the originally hydrophobic fluorinated cured film, when exposed to different liquid environments (immersion in water or in hydrocarbon), can undergo a significant surface reconstruction and become hydrophilic in a couple of days. In fact, the fluorinated chains on the cured film surface have enough molecular mobility to self-orient, being forced toward the bulk of the material. Such retraction of the fluorinated chains in the presence of a liquid leaves the

more hydrophilic moieties of the copolymer network (i.e., the non-fluorinated matrix) on the free surface and hence reduces the hydrophobic character of the film.

Figure 1 also shows that, once the cured films are air dried at RT, the contact angle considerably increases again, reaching approximately the contact angle value of the film stored in air, without previous immersion in a liquid. After re-exposing the film to air (and eventually subjecting it to an annealing treatment), the original surface properties are re-established: there is thus a recovery of the hydrophobicity, thanks to a re-orientation of the fluorinated chains toward the free surface. This behavior is reported in the literature, and defined as “flip-flop” phenomenon.[7] For the system under investigation, the fluorinated chains re-orientation during the air drying is a relatively fast process, especially for the cured films previously immersed in hexadecane. Nevertheless, the rearrangement process is not completely reversible, even after long drying, and a loss of about 10° in contact angle value can be observed (Figure 1). This effect could be due to retention or entrapment of water in the film, or a permanent damage of the polymer network.

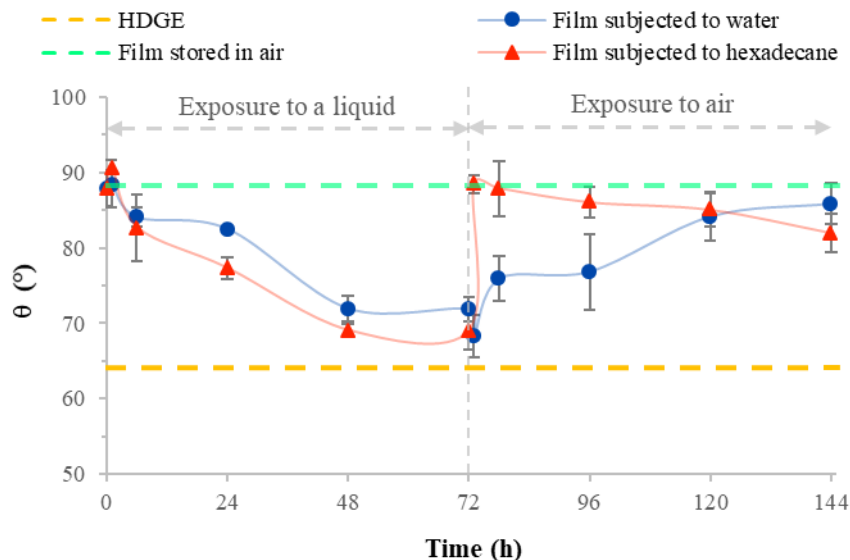

Figure 1. Static water contact angle (θ) of HDGE + 2wt% HFPO₁₀-MA as a function of the immersion time in water or hexadecane, and during the following drying at RT.

In order to better investigate the surface segregation behavior of the PFP AE comonomer and the occurring changes at the free surface due to dynamics of the polymer system, the surface morphology of the cured HDGE + 2wt% HFPO₁₀-MA films was investigated by AFM. As shown in Figure 2a, the addition of the fluoroalcohol has a remarkable effect on the copolymer surface structure, suggesting that between the PFP AE and the epoxy chains there is a clear phase separation at submicrometric level. This produces a morphology consisting of polydisperse spherical fluorinated domains, with an average size of 226 nm (Figure 2a), immersed in a continuous matrix. Accordingly, such structure produces an increase in surface roughness that reaches almost 21 nm ($S_q = 20.6$ nm), while HDGE photocured homopolymer films have a surface roughness S_q of 1.4 nm. The submicrometric surface phase separation is also confirmed by the fact that the cured copolymer films are completely transparent.

HDGE + 2wt% HFPO₁₀-MA films were then immersed in water for 24 h and subsequently analyzed by AFM. Figure 2b confirms that the water exposition causes a severe surface rearrangement of the PFP AE chains. After the immersion, no noticeable fluorinated domains can be seen on the copolymer surface, which is much smoother than before the immersion. The surface roughness is in fact strongly reduced by the contact with water ($S_q = 4.5$ nm).

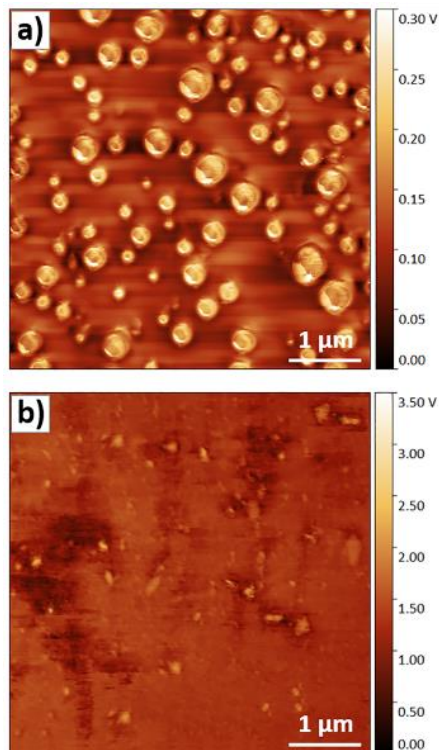

Figure 2. Surface morphology of the cured HDGE + 2wt% HFPO₁₀-MA films: tapping mode AFM $5 \times 5 \mu\text{m}^2$ phase images of a dry film (a) and of a film after 24 h immersion in water (b).

Therefore, water contact angle analysis and AFM study demonstrate that when the copolymeric photocured films are in air environment, the hydrophobic PFPAE chains are exposed on the free surface, while when the films are immersed in a liquid, a dramatic surface reorganization occurs, leading to an enforced orientation of the fluorinated chains toward the bulk and thus an exposure of the hydrophilic epoxy matrix on the outermost surface. This phenomenon is an important drawback for the application of the copolymeric films, as their surface properties can dramatically change only by exposure to different environments. Therefore, different strategies to control the PFPAE surface rearrangements and/or hinder them were developed, and each of them is discussed in a separate section below.

Variation of the length of the PFPAE comonomer chain

As first approach to try to control the copolymer surface rearrangements induced by the environment, a shorter PFPAE alcohol (i.e., HFPO₅-MA) is employed, in order to reduce the mobility of the fluorinated dangling chains and prevent their re-orientation when exposed to a liquid.

No adverse effects in terms of water contact angle of the dry film are observed by using a shorter fluorinated surface modifier, compared to the longer fluorinated alcohol performance, for the same HFPO_n-MA concentration.[24] The water contact angle values are in fact 93° and 88° for the photocured HDGE + 2wt% HFPO₅-MA and HDGE + 2wt% HFPO₁₀-MA copolymer, respectively. Even better, as shown in Figure 3, the reduction of the molecular mobility, attributable to the shorter and more rigid chains of HFPO₅-MA, leads to an excellent result for the cured films subjected to water for 3 days. The re-orientation of the fluorinated segments is hence almost completely suppressed, as indicated by the reduction of only around 10° of the water contact angle value. An exceptional behavior can be observed also in case of immersion of the copolymeric films in hexadecane, as their hydrophobicity decreases of only few degrees compared to the analogous dry films (Figure 3).

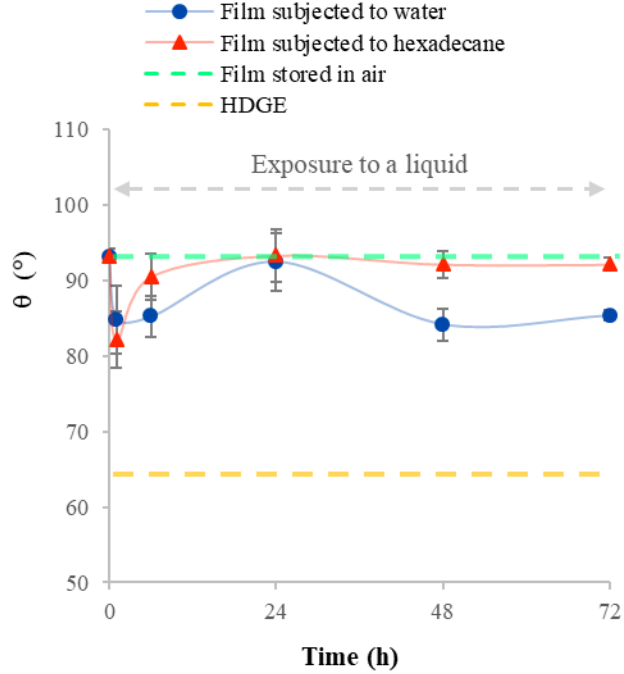

Figure 3. Static water contact angle (θ) of HDGE + 2wt% HFPO₅-MA as a function of the immersion time in water or hexadecane.

These results can be better understood observing the AFM surface morphologies of the HDGE + 2wt% HFPO₅-MA dry and wet films (Figure 4). Comparing Figure 4a and Figure 2a, a slightly different morphology is obtained when HFPO₅-MA is used as surface modifier (instead of HFPO₁₀-MA). In this case, the fluorinated domains have an average diameter of 215 nm and seem to be more uniformly distributed. This is probably due to the higher compatibility with HDGE matrix of the shorter HFPO₅-MA, compared to the higher molecular weight HFPO₁₀-MA (which contains more fluorine). AFM analysis of HDGE + 2wt% HFPO₅-MA films after 24 h immersion in water (Figure 4b) reveals a significant size reduction of the fluorinated domains, compared to the dry samples (Figure 4a). However, even if becoming very small, the phase-separated domains preserve a spherical shape and a regular dense distribution on the polymer surface. Moreover, surface roughness strongly decreases with water immersion: $S_q = 5.1$ nm for

the wet sample, while $S_q = 10.5$ nm for the dry sample. However, although the surface of the HDGE + 2wt% HFPO₅-MA copolymer films is subjected to a partial reconstruction after water immersion, their performance results to be approximately the same of that shown by dry samples, as confirmed by contact angle measurements (Figure 3).

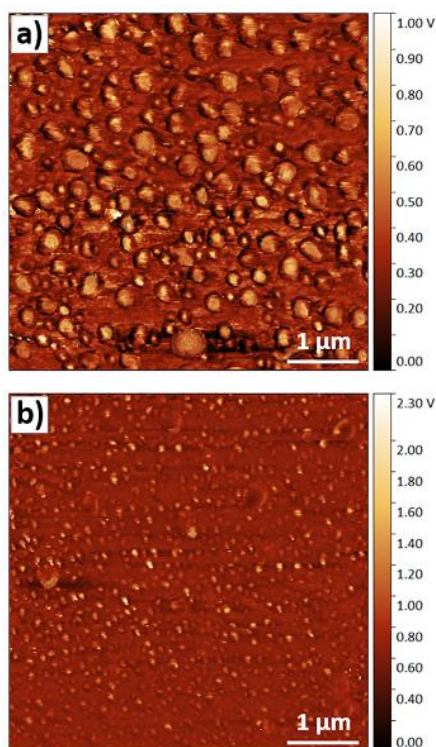

Figure 4. Surface morphology of the cured HDGE + 2wt% HFPO₅-MA films: tapping mode AFM $5 \times 5 \mu\text{m}^2$ phase images of a dry film (a) and of a film after 24 h immersion in water (b).

Therefore, the use of a shorter and less mobile fluorinated surface modifier is proved to be a successful strategy to hinder the surface reconstruction, because it allows to achieve similar performances in terms of water static contact angle, without suffering of a pronounced re-orientation of the fluorinated segments when exposed to different environments.

Increasing the stiffness of the epoxy matrix

The epoxy resin used for the copolymers previously described (i.e., HDGE) is quite flexible (being its T_g far below RT, Figure 5): this allows fluorinated chains movements and thus surface reconstructions when the PFPAAE alcohol HFPO₁₀-MA is added as surface modifier (Figure 1). As another strategy to prevent the fluorinated comonomer chains rearrangement induced by exposure to liquids, the tuning of the matrix stiffness has been investigated. In fact, the use of a matrix with a high T_g can be expected to limit the fluorinated dangling chains mobility by surrounding them rigidly. Accordingly, a series of photocurable resins was taken into account to replace HDGE. CE resin is commonly used in cationic polymerizations, and after crosslinking exhibits a very stiff structure, as confirmed by its high T_g of 187 °C (Figure 5). In this work, a mildly rigid 1:1 HDGE:CE blend, showing a T_g above the RT and below 100 °C ($T_g = 81$ °C, Figure 5), was chosen.

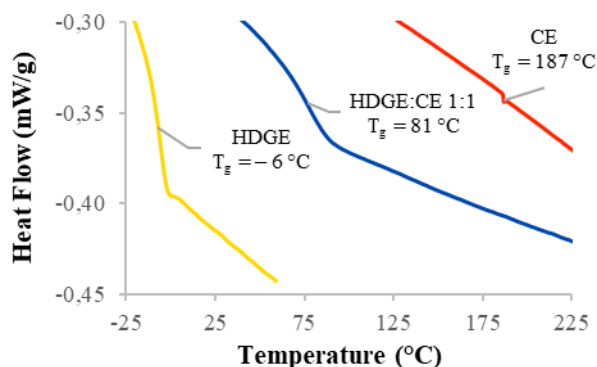

Figure 5. DSC thermograms of the photocured epoxy resins HDGE and CE respectively and their 1:1 HDGE:CE blend.

Photocured 1:1 HDGE:CE copolymer is hydrophilic with a water contact angle ($\theta = 61^\circ$) comparable with that of pure HDGE. Consequently, HDGE + 2wt% HFPO₁₀-MA and 1:1

HDGE:CE + 2wt% HFPO₁₀-MA films show similar wettabilities: $\theta = 88^\circ$ and $\theta = 93^\circ$, respectively. As shown in Figure 6, using 1:1 HDGE:CE blend as matrix, the HFPO₁₀-MA chains mobility is fully inhibited when the cured copolymeric films are exposed to water, and no decrease in water contact angle value can be observed after 3 days of immersion. Furthermore, when the photocured films are subjected to hexadecane, their contact angle value is quite stable, fluctuating around the contact angle of the dry film stored in air. The observed slight increase of the water contact angle can be explained with a little swelling of hexadecane from the outermost copolymer layer.

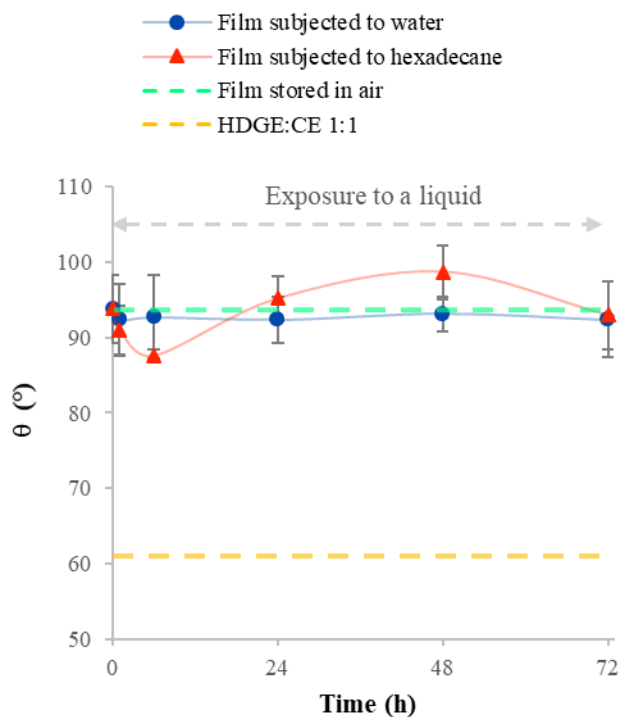

Figure 6. Static water contact angle (θ) of 1:1 HDGE:CE + 2wt% HFPO₁₀-MA as a function of the immersion time in water or hexadecane.

From the AFM analysis of 1:1 HDGE:CE + 2wt% HFPO₁₀-MA dry films (Figure 7a), a significant difference in morphology can be noted, compared to HDGE + 2wt% HFPO₁₀-MA

films (Figure 2a): in the former case, no phase separation is detected and a much smoother surface is obtained ($S_q = 0.9$ nm). Due the absence of fluorinated phase segregation into submicrometric domains, it seems that the fluorinated comonomer shows a better compatibility with 1:1 HDGE:CE blend than with pure HDGE monomer. Moreover, when 1:1 HDGE:CE + 2wt% HFPO₁₀-MA films are immersed in water for 24 h (Figure 7b), the surface morphology does not change and nearly the same surface roughness is shown ($S_q = 0.8$ nm).

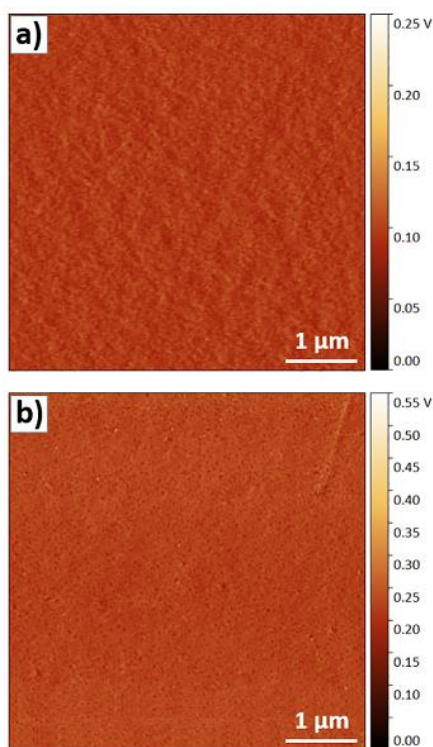

Figure 7. Surface morphology of the cured 1:1 HDGE:CE + 2wt% HFPO₁₀-MA films: tapping mode AFM $5 \times 5 \mu\text{m}^2$ phase images of a dry film (a) and of a film after 24 h immersion in water (b).

When 1:1 HDGE:CE is used as epoxy matrix, the mobility of the PFPAE chains is suppressed because the fluorinated comonomer is surrounded by a stiff network, and therefore the surface

reconstruction is minimized. Accordingly, as contact angle measurements have also demonstrated, the surface features of 1:1 HDGE:CE + 2wt% HFPO₁₀-MA photocured films are independent on their immersion in both polar and non-polar liquids.

Change of the functionality of the PFPAE comonomer

In order to contrast the decrease in hydrophobicity induced by the rearrangements of the low surface energy additive when exposed to an external environment, it is also possible to modify the fluorinated comonomer functionality. In this way, a different network structure could be obtained during the cationic photopolymerization of the system. Therefore, HFPO₁₀-MA was appropriately modified by reaction with epibromohydrin, obtaining a PFPAE monoepoxy monomer (HFPO₁₀-MEpo), as described in Scheme 1, able to participate in the photoinduced cationic copolymerization.

The photocured HDGE + 2wt% HFPO₁₀-MEpo films are found to be hydrophobic, since their static water contact angle is above 90° ($\theta = 95^\circ$). As can be seen in Figure 8, after 3 days of immersion in water, the wettability of the copolymer does not change. Similar performances are shown when the cured films are subjected to hexadecane; but in this case, surprisingly, the water contact angle value increases of around 10°. This behavior could be due to the hexadecane diffusion into the epoxy matrix outermost layers and thus the formation of a shallow lipophilic wetted layer. Such layer could further improve the already hydrophobic character of the HDGE + 2wt% HFPO₁₀-MEpo films.

Therefore, when the PFPAE epoxy comonomer is used, the fluorinated surface segregation layer sustains hydrophobicity even upon the immersion of the film in a polar or apolar liquid.

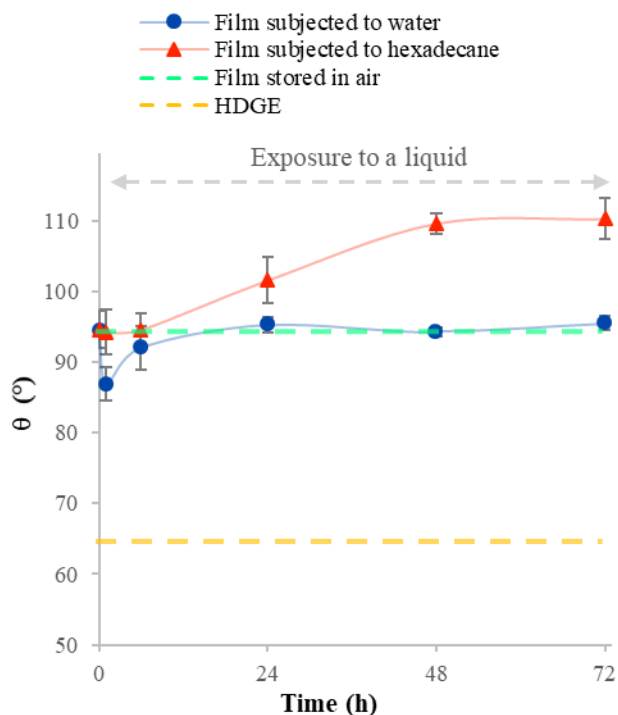

Figure 8. Static water contact angle (θ) of HDGE + 2wt% HFPO10-MEpo as a function of the immersion time in water or hexadecane.

As for the dry HDGE + 2wt% HFPO₁₀-MA films, also the AFM phase images of the HDGE + 2wt% HFPO₁₀-MEpo films stored in air (Figure 9a) indicate a remarkable phase separation at submicrometric level, characterized by roughly spherical shaped fluorinated domains. The domains average size (diameter = 226 nm) and surface roughness ($S_q = 20.6$ nm) are very similar to those observed when HFPO₁₀-MA is used as fluorinated additive. In fact, the hydrophobic properties granted to the photocured epoxy copolymer by the two different PFPPE modifiers, alcohol- and epoxy-functionalized, result to be similar.

However, significant differences emerge when the fluoroalcohol is replaced by the fluoroepoxide in the photocured films subjected to water. After 24 h of immersion, while the fluorinated alcohol chains suffer a severe surface reconstruction (Figure 2b) and, consequently, a dramatic

reduction of hydrophobicity happens, when HFPO₁₀-MEpo is used, after the exposure to water, no changes in water wettability occur. Even if a reduction of the surface roughness ($S_q = 4.5$ nm) and of the size of the fluorinated domains can be observed (Figure 9b), a considerable fluorinated chain reorganization does not take place. Therefore, the numerous remaining fluorinated domains segregated at the free surface still perform their function of low surface energy constituents, leading to advanced hydrophobic properties even when the films are exposed for long times to different environments.

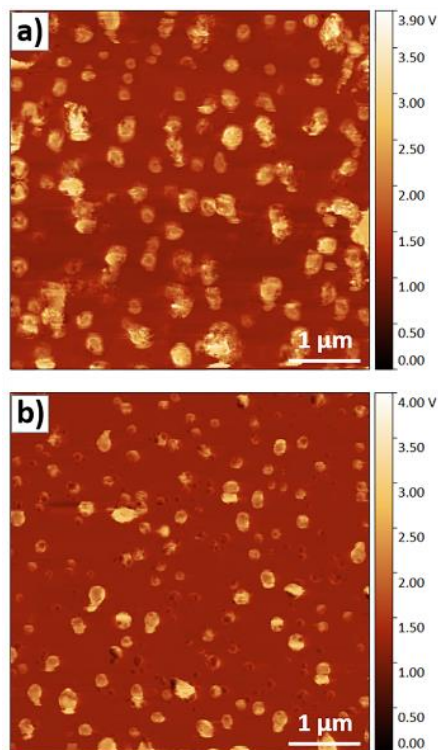

Figure 9. Surface morphology of the cured HDGE + 2wt% HFPO₁₀-MEpo: tapping mode AFM $5 \times 5 \mu\text{m}^2$ phase images of a dry film (a) and of a film after 24 h immersion in water (b).

To fully understand the different rearrangement behavior of the fluorinated chains when a monoalcohol or a monoepoxide comonomer is used, it is necessary to consider how the PFP AE

modifiers, functionalized with different end-groups, participate to the photoinduced cationic polymerization, and how they bond to the copolymer network structure that is formed. In fact, although all the investigated copolymeric films show high degrees of final conversion (see Fourier Transform-Infra Red spectroscopy analyses reported in the Supporting Information), different polymerization and crosslinking mechanisms can provide different molecular architectures. As shown in Scheme 2a, as a cationic mechanism applies in the curing of epoxy resins, a fluoroalcohol R_f-OH (e.g., HFPO_n-MA) can act as chain transfer agent involving the hydroxyl groups.[25,37] The fluoroalcohol is then covalently linked to the network and the fluorinated dangling moieties R_f are at the end of each terminated copolymer chain. Whereas, HFPO₁₀-MEpo participates to the propagation step via ring opening cationic polymerization (Scheme 2b). In this case, each R_f segment is part of the growing chain: therefore, along the same chain, once terminated, there could be one or more dangling fluorinated chains at a certain distance from each other.

Consequently, these two mechanisms lead to different positioning of the PFP AE dangling chains and their interchain distance, and different packing structure of the copolymer chains. Based on these assumptions, in the HDGE + 2wt% HFPO₁₀-MA copolymer, fluorinated segments always terminate chains and only one fluorinated segment is present as end-group of each terminated chain. This makes the PFP AE segments highly mobile, leading to a deep surface reconstruction. On the contrary, in the HDGE + 2wt% HFPO₁₀-MEpo copolymer, the fluorinated dangling chains are part of the network, more packed, and closer to each other, which limits their mobility and suppress the surface rearrangement. The different molecular architectures, obtained when HFPO_n-MA or HFPO_n-MEpo is used as fluorinated additive, are illustrated in Figure 10.

Scheme 2. Chain transfer mechanism in the photoinduced ring-opening polymerization of epoxides by fluorinated alcohols R_f -OH (a); propagation mechanism in the photoinduced ring opening cationic polymerization of epoxides by fluorinated epoxides (b). R_f stands for the oligo(HFPO) chain.

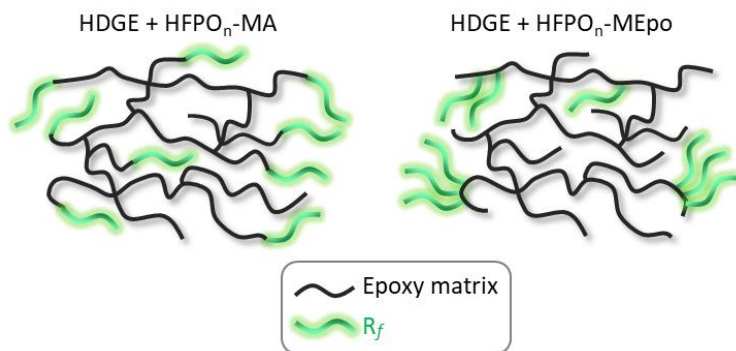
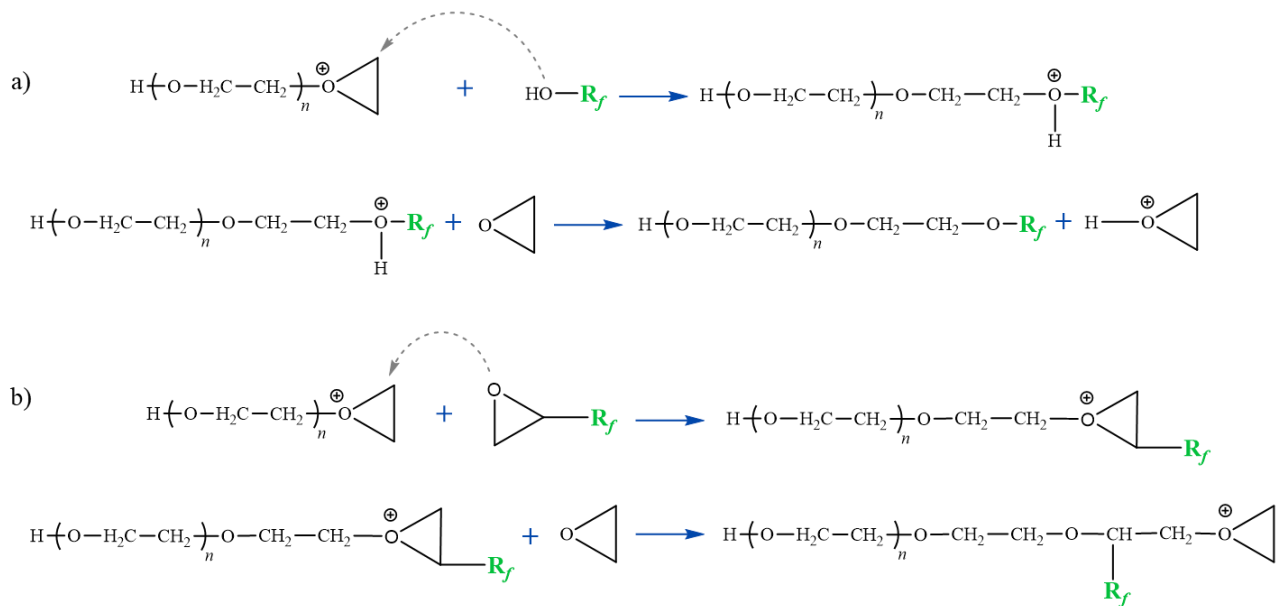

Figure 10. Scheme of the molecular architecture of cured HDGE + HFPO_n-MA and HDGE + HFPO_n-MEpo. R_f stands for the oligo(HFPO) chain.

Table 1. Static contact angle (θ) and surface energy (γ), divided in its dispersive (γ^d) and polar (γ^p) components, on the air side of HDGE, 1:1 HDGE:CE, HDGE + 2 wt% HFPO₁₀-MA, HDGE + 2 wt% HFPO₅-MA, 1:1 HDGE:CE + 2 wt% HFPO₁₀-MA, and HDGE + 2 wt% HFPO₁₀-MEpo, before and after 72 h of immersion in water.

(Co)polymer	Film state	$\theta_{\text{water}} (^{\circ})$	Surface energy (mN/m)		
			γ^d	γ^p	γ
HDGE	dry	64	27	15	42
1:1 HDGE:CE	dry	61	27	16	43
HDGE + 2 wt% HFPO ₁₀ -MA	dry	88	13	4	17
	72 h in water	72	18	15	33
HDGE + 2 wt% HFPO ₅ -MA	dry	93	13	6	19
	72 h in water	85	14	9	23
1:1 HDGE:CE + 2 wt% HFPO ₁₀ -MA	dry	93	14	9	23
	72 h in water	92	18	4	22
HDGE+ 2 wt% HFPO ₁₀ -MEpo	dry	95	17	4	21
	72 h in water	95	14	4	19

To summarize, surface energy values of all the investigated copolymer films, in the dry state and after 72 h of immersion in water, are collected in Table 1. As can be clearly noted, the surface energy strongly decreases in the presence of fluorinated comonomers, reaching values as low as 17 mN/m for the HDGE + 2wt% HFPO₁₀-MA system. However, when such copolymer is immersed in water, its surface energy doubles ($\gamma = 33$ mN/m), due to the surface rearrangements of the mobile PFPAE chains. Different strategies are demonstrated to hinder or completely suppress the surface rearrangements, namely the modification of the fluorinated alcohol chain length and its functionality, and the tuning of the stiffness of the epoxy matrix. Thus, the surface energy of the wet copolymer films is kept lower than 23 mN/m. It is important to notice that controlling the surface reorganization is essential to maintain the surface characteristics and high

performance of the material through its whole life-cycle, even when it is exposed to different environments.

CONCLUSIONS

Low surface energy photocured copolymers were produced through cationic UV-curing technique using epoxy systems in the presence of newly synthesized monofunctional PFP AE additives. Thanks to the surface segregation of the fluorinated comonomer, which spontaneously migrates towards the less polar surface before and during the photocuring process, a selective surface modification is induced, leading to a low surface energy film in a simple and effective way. However, the copolymer surface properties can be lost and recovered over time due to PFP AE chains reorganizations when the polymer surfaces are subjected to different environments (e.g., polluted air, immersion in water or oil-based solutions). Various strategies have been investigated to control the environmentally induced rearrangements of the fluorinated dangling chains. From a physical point of view of the surface reconstruction mechanism, the shortening of the fluorinated chains and the matrix stiffening have led to a minimization of the PFP AE segments mobility and, therefore, to a surface rearrangement inhibition. Considering the chemical aspects that underlie the PFP AE chains reorganization phenomenon, it was possible to change the way in which the fluorinated comonomers react and take part to the forming network during cationic photopolymerization by changing their functional end-group. Using an epoxy functionality for the PFP AE comonomer led to a remarkable reduction in the fluorinated chains mobility. Therefore, in this work, it was demonstrated that different successful strategies can be applied to low surface energy fluorinated photocured copolymers to preserve their advanced

surface performances by controlling the environmentally induced rearrangements of PFPPE chains.

ASSOCIATED CONTENT

Supporting Information. The Supporting Information is available free of charge.

Characterization of HFPO₁₀-MEpo monomer; FT-IR study of the photopolymerization reaction.

AUTHOR INFORMATION

Corresponding Authors

* E-mail: giuseppe.trusiano@polito.it (G.T.).

* E-mail: alessandra.vitale@polito.it (A.V.).

ACKNOWLEDGMENT

This research project has received funding from the European Union's Horizon 2020 research and innovation program under grant agreement No. 690917 – PhotoFluo, and from the Natural Sciences and Engineering Research Council of Canada (NSERC), Discovery Grants Program RGPIN-2015-05513.

REFERENCES

- [1] F. Garbassi, M. Morra, E. Ochiello., Polymer surfaces: from physics to technology, *Polym. Int.* 36 (1995) 1–300. doi:10.1016/j.avsg.2011.12.015.
- [2] D.R. Iyengar, S.M. Perutz, C.-A. Dai, C.K. Ober, E.J. Kramer, Surface Segregation Studies of Fluorine-Containing Diblock Copolymers, *Macromolecules.* 29 (1996) 1229–1234. doi:10.1021/ma950544z.
- [3] S.J. Ebbens, J.P.S. Badyal, Surface Enrichment of Fluorochemical-Doped Polypropylene Films, *Langmuir.* 17 (2001) 4050–4055. doi:10.1021/la010081s.
- [4] J.A. Gardella, C.M. Mahoney, Determination of oligomeric chain length distributions at surfaces using ToF-SIMS: Segregation effects and polymer properties, *Appl. Surf. Sci.* 231–232 (2004) 293–288. doi:10.1016/j.apsusc.2004.03.061.
- [5] X. Zeng, Y. Ma, Y. Wang, Enhancing the low surface energy properties of polymer films with a dangling shell of fluorinated block-copolymer, *Appl. Surf. Sci.* 338 (2015) 190–196. doi:10.1016/j.apsusc.2015.02.134.
- [6] B. Ameduri, R. Bongiovanni, G. Malucelli, A. Pollicino, A. Priola, New fluorinated acrylic monomers for the surface modification of UV-curable systems, *J. Polym. Sci. A. Polym. Chem.* 37 (1999) 77–87. doi:10.1002/(sici)1099-0518(19990101)37:1<77::aid-pola9>3.0.co;2-0.
- [7] A. Vitale, R. Bongiovanni, B. Ameduri, Fluorinated oligomers and polymers in photopolymerization, *Chem. Rev.* 115 (2015) 8836–8866. doi:10.1021/acs.chemrev.5b00120.
- [8] A. Vitale, S. Touzeau, F. Sun, R. Bongiovanni, Compositional Gradients in Siloxane Copolymers by Photocontrolled Surface Segregation, *Macromolecules.* 51 (2018) 4023–

4031. doi:10.1021/acs.macromol.8b00339.
- [9] J.C.J. Yarbrough, J.J.P. Rolland, J.J.M. DeSimone, M.E. Callow, J.A. Finlay, J.A. Callow, Contact angle analysis, surface dynamics, and biofouling characteristics of cross-linkable, random perfluoropolyether-based graft terpolymers, *Macromolecules*. 39 (2006) 2521–2528. doi:10.1021/ma0524777.
- [10] D. Chandler, Interfaces and the driving force of hydrophobic assembly, *Nature*. (2005) 640–647. doi:10.1038/nature04162.
- [11] K. Liu, L. Jiang, Bio-Inspired Self-Cleaning Surfaces, *Annu. Rev. Mater. Res.* 42 (2012) 231–263. doi:10.1146/annurev-matsci-070511-155046.
- [12] A.G. Nurioglu, A.C.C. Esteves, G. De With, Non-toxic, non-biocide-release antifouling coatings based on molecular structure design for marine applications, *J. Mater. Chem. B*. (2015) 6547–6570. doi:10.1039/c5tb00232j.
- [13] Y. Zhang, F. Karasu, C. Rocco, L.G.J. van der Ven, R.A.T.M. van Benthem, X. Allonas, C. Croutxé-Barghorn, A.C.C. Esteves, G. de With, PDMS-based self-replenishing coatings, *Polymer (Guildf)*. 107 (2016) 249–262. doi:10.1016/j.polymer.2016.11.026.
- [14] C.M. Friesen, B. Améduri, Outstanding telechelic perfluoropolyalkylethers and applications therefrom, *Prog. Polym. Sci.* 81 (2018) 238–280. doi:10.1016/j.progpolymsci.2018.01.005.
- [15] A. Vitale, A. Priola, C. Tonelli, R. Bongiovanni, Nanoheterogeneous networks by photopolymerization of perfluoropolyethers and acrylic co-monomers, *Polym. Int.* 62 (2013) 1395–1401. doi:10.1002/pi.4436.
- [16] C. Bonneaud, M. Decostanzi, J. Burgess, G. Trusiano, T. Burgess, R.M. Bongiovanni, C. Joly-Duhamel, C.M.C.M. Friesen, Synthesis of α,β -unsaturated esters of

- perfluoropolyalkylethers (PFPAEs) based on hexafluoropropylene oxide units for photopolymerization, *RSC Adv.* 8 (2018) 32664–32671. doi:10.1039/c8ra06354k.
- [17] D.W. Smith, S.T. Iacono, S.S. Iyer, *Handbook of Fluoropolymer Science and Technology*, 2014.
- [18] R. Bongiovanni, A. Medici, A. Zompatori, S. Garavaglia, C. Tonelli, Perfluoropolyether polymers by UV curing: Design, synthesis and characterization, *Polym. Int.* 61 (2012) 65–73. doi:10.1002/pi.3149.
- [19] R. Bongiovanni, A. Nelson, A. Vitale, E. Bernardi, Ultra-thin films based on random copolymers containing perfluoropolyether side chains, *Thin Solid Films.* 520 (2012) 5627–5632. doi:10.1016/j.tsf.2012.04.021.
- [20] A. Vitale, S. Merlo, G. Rizza, G. Melilli, M. Sangermano, UV curing of perfluoropolyether oligomers containing graphene nanosheets to enhance water-vapor barrier properties, *Macromol. Chem. Phys.* 215 (2014) 1588–1592. doi:10.1002/macp.201400225.
- [21] A. Vitale, A. Pollicino, E. Bernardi, R. Bongiovanni, Ultrathin perfluoropolyether coatings for silicon wafers: A XPS study, *Prog. Org. Coatings.* 78 (2015) 480–487. doi:10.1016/j.porgcoat.2014.06.014.
- [22] Z. Wang, J.C. Dewitt, C.P. Higgins, I.T. Cousins, A Never-Ending Story of Per- and Polyfluoroalkyl Substances (PFASs)?, *Environ. Sci. Technol.* 51 (2017) 2508–2518. doi:10.1021/acs.est.6b04806.
- [23] G. Malinverno, G. Pantini, J. Bootman, Safety evaluation of perfluoropolyethers, liquid polymers used in barrier creams and other skin-care products, *Food Chem. Toxicol.* 34 (1996) 693–650. doi:10.1016/0278-6915(96)00023-3.

- [24] G. Trusiano, M. Rizzello, A. Vitale, J. Burgess, C.M. Friesen, C. Joly-Duhamel, R.M. Bongiovanni, Modification of photocurable epoxides by new perfluoropolyalkylether alcohols for obtaining self-cleaning coatings, *Prog. Org. Coatings*. 132 (2019) 257–263. doi:10.1016/j.porgcoat.2019.02.043.
- [25] M. Sangermano, R. Bongiovanni, A. Priola, D. Pospiech, Fluorinated alcohols as surface-active agents in cationic photopolymerization of epoxy monomers, *J. Polym. Sci. Part A Polym. Chem.* 43 (2005) 4144–4150. doi:10.1002/pola.20865.
- [26] A.C.C. Esteves, K. Lyakhova, L.G.J. Van Der Ven, R.A.T.M. Van Benthem, G. De With, Surface segregation of low surface energy polymeric dangling chains in a cross-linked polymer network investigated by a combined experimental-simulation approach, *Macromolecules*. 46 (2013) 1993–2002. doi:10.1021/ma302236w.
- [27] A.C.C. Esteves, I.D. Gunbas, J.M. Van Riel, B.A.J. Noordover, G. De With, R.A.T.M. Van Benthem, Time-resolved surface rearrangements of polymer films monitored by dynamic recovery contact angle (DRCA), *RSC Adv.* 4 (2014) 20094–20101. doi:10.1039/c4ra01329h.
- [28] J.L. Yagüe, K.K. Gleason, Enhanced cross-linked density by annealing on fluorinated polymers synthesized via initiated chemical vapor deposition to prevent surface reconstruction, *Macromolecules*. 46 (2013) 6548–6554. doi:10.1021/ma4010633.
- [29] H. Tan, J. Li, M. Guo, R. Du, X. Xie, Y. Zhong, Q. Fu, Phase behavior and hydrogen bonding in biomembrane mimicing polyurethanes with long side chain fluorinated alkyl phosphatidylcholine polar head groups attached to hard block, *Polymer (Guildf)*. 45 (2005) 1495–1502. doi:10.1016/j.polymer.2005.06.032.
- [30] P. Game, D. Sage, J.P. Chapel, Surface mobility of polyurethane networks containing

- fluorinated amphiphilic reactive additives, *Macromolecules*. 35 (2002) 917–923.
doi:10.1021/ma001988k.
- [31] J.K. Pike, T. Ho, K.J. Wynne, Water-induced surface rearrangements of poly(dimethylsiloxane-urea-urethane) segmented block copolymers, *Chem. Mater.* 8 (1996) 856–860. doi:10.1021/cm9504596.
- [32] D.R. Iyengar, S.M. Perutz, C.-A. Dai, C.K. Ober, E.J. Kramer, Surface Segregation Studies of Fluorine-Containing Diblock Copolymers †, *Macromolecules*. (1996).
doi:10.1021/ma950544z.
- [33] Y. Wang, J. Knapp, A. Legere, J. Raney, L. Li, Effect of end-groups on simultaneous oleophobicity/hydrophilicity and anti-fogging performance of nanometer-thick perfluoropolyethers (PFPEs), *RSC Adv.* 5 (2015) 30570–30576. doi:10.1039/c5ra04483a.
- [34] J.L. Howell, N. Lu, C.M. Friesen, New derivatives of poly-hexafluoropropylene oxide from the corresponding alcohol, *J. Fluor. Chem.* 126 (2005) 281–288.
doi:10.1016/j.jfluchem.2004.09.020.
- [35] S. Turri, M. Scicchitano, C. Tonelli, End Group Chemistry of Fluoro-Oligomers: Highly Selective Syntheses of Diepoxy, Diallyl, and Tetraol Derivatives, *J. Polym. Sci. Part A Polym. Chem.* 34 (1996) 3263–3275.
- [36] S. Wu, *Polymer interface and adhesion*, M. Dekker. (1982). doi:10.1201/9780203742860.
- [37] J. V. Crivello, S. Liu, Photoinitiated cationic polymerization of epoxy alcohol monomers, *J. Polym. Sci. Part A Polym. Chem.* 38 (2000) 389–401. doi:10.1002/(SICI)1099-0518(20000201)38:3<389::AID-POLA1>3.0.CO;2-G.
- [38] R. Bongiovanni, G. Beamson, A. Mamo, A. Priola, A. Recca, C. Tonelli, High resolution XPS investigation of photocured films containing perfluoropolyether acrylates, *Polymer*

- (Guildf). 41 (2000) 409–414.
- [39] R. Bongiovanni, G. Malucelli, V. Lombardi, A. Priola, V. Siracusa, C. Tonelli, A. Di Meo, Surface properties of methacrylic copolymers containing a perfluoropolyether structure, *Polymer (Guildf)*. 42 (2001) 2299–2305. doi:10.1016/S0032-3861(00)00557-7.
- [40] Y. Tezuka, T. Ono, K. Imai, Environmentally induced macromolecular rearrangement on the surface of polyurethane-polysiloxane graft copolymers, *J. Colloid Interface Sci.* 136 (1990) 408–414. doi:10.1007/BF00170621.
- [41] S.H. Lee, E. Ruckenstein, Surface restructuring of polymers, *J. Colloid Interface Sci.* 120 (1987) 529–536. doi:10.1016/0021-9797(87)90380-8.
- [42] J. Howarter, J. Youngblood, Self-Cleaning and Anti-Fog Surfaces via Stimuli-Responsive Polymer Brushes, *Adv. Mater.* 19 (2007) 3838–3843. doi:10.1002/adma.200700156.
- [43] J.A. Howarter, J.P. Youngblood, Self-cleaning and next generation anti-fog surfaces and coatings, *Macromol. Rapid Commun.* 29 (2008) 455–466. doi:10.1002/marc.200700733.

TABLE OF CONTENTS GRAPHIC FOR SUBMISSIONS

