

Towards the Design of an Impedance-Controlled HD-sEMG Amplifier: A Feasibility Study

*Original*

Towards the Design of an Impedance-Controlled HD-sEMG Amplifier: A Feasibility Study / Cerone, G.L., Gazzoni, M.. - ELETTRONICO. - (2019). (EMB Conference 2019 Berlin (Germany) 23-27 July 2019) [10.1109/EMBC.2019.8857410].

*Availability:*

This version is available at: 11583/2756257 since: 2019-09-29T22:59:49Z

*Publisher:*

IEEE

*Published*

DOI:10.1109/EMBC.2019.8857410

*Terms of use:*

This article is made available under terms and conditions as specified in the corresponding bibliographic description in the repository

*Publisher copyright*

IEEE postprint/Author's Accepted Manuscript

©2019 IEEE. Personal use of this material is permitted. Permission from IEEE must be obtained for all other uses, in any current or future media, including reprinting/republishing this material for advertising or promotional purposes, creating new collecting works, for resale or lists, or reuse of any copyrighted component of this work in other works.

(Article begins on next page)

# Towards the Design of an Impedance-Controlled HD-sEMG Amplifier: A Feasibility Study

Giacinto Luigi Cerone, *Member, IEEE*, and Marco Gazzoni

**Abstract**— The use of multiple surface EMG electrodes (High-Density surface EMG – HD-sEMG) allows the extraction of anatomical and physiological information either at the muscle or at the motor unit level with applications in several fields ranging from clinical neurophysiology to the control of prosthetic devices. These applications need to acquire monopolar sEMG signals free from power line interference arising from the capacitive coupling between the subject, the acquisition system and the power line. The aim of this work is to provide a common mode analysis of the detection system used to collect monopolar sEMG signals, characterizing different configuration of the reference electrodes leading to different behaviors in terms of immunity to the power line interference. Based on the experimental results, a new impedance-controlled HD-sEMG signal amplifier is proposed and discussed.

## I. INTRODUCTION

Surface Electromyography (sEMG) is the electrophysiological technique used to analyze the electrical signal generated during a muscle contraction and detected by means of electrodes placed over the skin. The use of multiple sEMG electrodes (High-Density surface EMG – HD-sEMG) allows the extraction of anatomical and physiological information either at the muscle and at the motor unit level [1] with applications in several fields ranging from clinical neurophysiology to the control of prosthetic devices [2], [3]. HD-sEMG signals are usually detected with a monopolar configuration since it preserves all the information contained in the signal generated by the motor units within the detection volume, including the end-of fiber effect [4], [5]. The monopolar detection technique consists into the signal acquisition using one or more exploring electrodes and one reference electrode.

Fig. 1 shows a typical setup for the detection of HD-sEMG signals using a grid of electrodes placed over the skin under the muscle. The monopolar reference electrode is used as a common voltage reference for the detection of sEMG signals while the ground reference electrode is used to lower the common mode voltage on the subject's skin. The  $A_1$ - $A_n$  amplifiers are usually three-electrodes bio-potential amplifiers having an instrumentation amplifier as a front-end circuit [6].

The non-invasive neuromuscular system assessment, especially at the motor unit level, requires the acquisition of good quality signals, free of power line interference, (e.g. caused by parasitic capacitive coupling with the power line) [4]. Different offline processing techniques have been proposed to remove the residual power line interference collected by the sEMG amplifier [7], [8].

## HD-sEMG Monopolar Detection

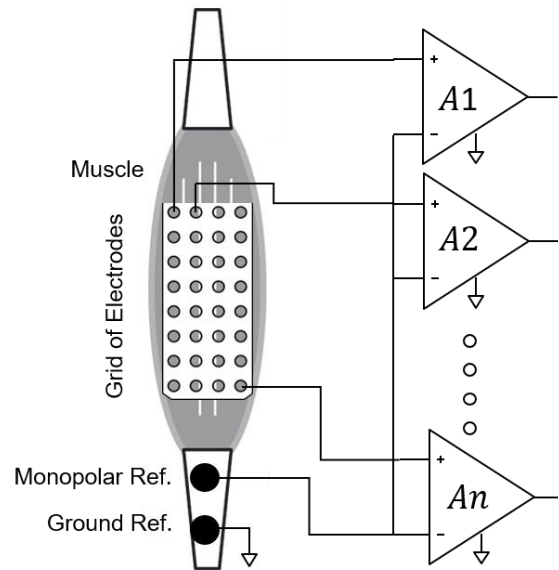

Figure 1. Monopolar detection of HD-sEMG signals using a grid of surface electrodes placed over the muscle of interest. Two electrodes are used as monopolar and ground reference respectively. The  $A_1$ - $A_n$  amplifiers are usually three-electrodes bio-potential amplifiers having an instrumentation amplifier as a front-end circuit.

Due to the high number of electrodes positioned on the same muscle, exploring electrodes used in HD-sEMG are usually small in size ( $<20 \text{ mm}^2$ ). Consequently, a high impedance at the electrode-skin interface results, thus influencing the power line interference rejection characteristics of the amplifier.

The aim of this work is to: (1) give a common mode analysis of the detection system used to collect monopolar sEMG signals; (2) experimentally characterize different configurations of the reference electrodes allowing the minimization of the power line interference collected by the front-end amplifier; (3) demonstrating the feasibility of an impedance-controlled bio-potential amplifier for the detection of monopolar sEMG signals in HD-sEMG applications. A first, preliminary, block diagram of such device will be proposed.

\*Research supported by the bank foundation Compagnia di San Paolo. G.L. Cerone and M. Gazzoni are with Laboratory for Engineering of the Neuromuscular System (LISiN), Department of Electronics and

Telecommunications, Politecnico di Torino, Torino, Italy (corresponding author to: giacintoluigi.cerone@polito.it).

## II. MONOPOLAR DETECTION OF SEMG SIGNALS

### A. Common Mode Analysis

Fig. 2a illustrates the capacitive coupling between a ground referred power line source ( $V_{PL}$ ) and a subject. The  $C_1$  (0.5 pF – 5 pF) and  $C_2$  (5 pF – 500 pF) stray capacitances [9]–[13] model the capacitive coupling between the subject and the power line active phase and ground respectively. Considering the body as a low impedance path, the common mode voltage ( $V_C'$ ) due to the power line interference on the subject's skin can range between hundreds of milli-Volts (RMS) to tens of Volts (RMS). Fig. 2b shows the Thevenin equivalent circuit of the subject-power line capacitive coupling where:

$$C_{eq} = \frac{C_1 C_2}{C_1 + C_2}, \quad V_{eq} = V_{PL} \quad (1)$$

Such a circuit represents the common mode voltage at the input of the electrode-amplifier system used to collect sEMG signals. The overall system is composed of the subject, the electrodes and the bio-potential amplifier. The complete electrical model used to study power line interference is represented by the circuit shown in Fig. 2c.

$R_i$  represents the input impedance (modeled as purely resistive for simplicity) of the bio-potential amplifier and  $Z_{e1}$  is the impedance at the electrode-skin interface where sEMG signals are collected (exploring electrode).  $Z_{r1}$  and  $Z_{r2}$  are the electrode-skin impedances of the monopolar and amplifier ground references respectively.  $C_p$  represents the stray capacitance between the amplifier's reference and the power line ground. It is present if, as usual, the system is floating with respect to ground (e.g. if it is battery powered).

The electrode represented by  $Z_{r2}$  is commonly used to reduce the common mode voltage at the amplifier's input ( $V_C$ ). Considering the  $Z_{r2}$  impedance purely resistive ( $Z_{r2}=R_{r2}$ ), as in the case of Ag/AgCl electrodes usually used to detect sEMG signals, the amplitude of the common mode voltage  $V_C$  is given by:

$$|V_C| = V_{eq} \frac{2\pi f R_{r2} C'_{eq}}{\sqrt{1 + (2\pi f R_{r2} C'_{eq})^2}}, \quad C'_{eq} = \frac{(C_1 + C_2) C_p}{(C_1 + C_2 + C_p)} \quad (2)$$

The common mode input voltage  $V_C$  is transformed into a differential one depending on the amplifier's CMRR, the input impedance and the electrode-skin impedance unbalance between the exploring and the monopolar reference electrodes ( $Z_{e1} - Z_{r1}$ ) as in (3) [6], [14], [15].

The electrode-skin impedance unbalance  $Z_{e1} - Z_{r1}$  is particularly relevant in the case of HD-sEMG recordings, where small exploring electrodes (diameter < 5 mm) are used to collect signals by means of grid or array of electrodes, resulting in an electrode-skin impedance from tens to several hundreds of kilo-Ohms [16], [17].

The output referred power line interference  $V_{ORPL}$  is given by:

$$V_{ORPL} = A_d |V_C| \left( \frac{1}{CMRR} + \frac{|Z_{e1} - Z_{r1}|}{R_i} \right) \quad (3)$$

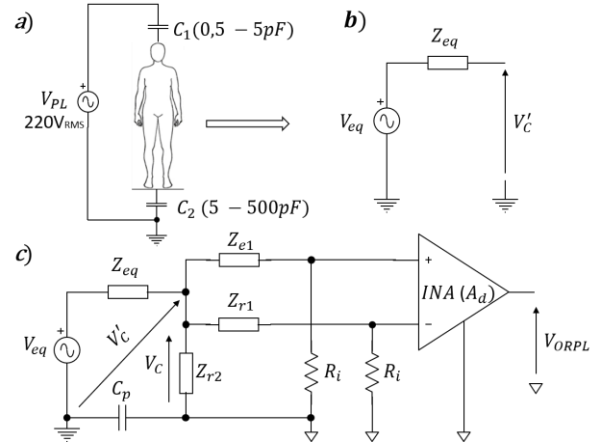

Figure 2. a) Capacitive coupling between a ground referred power line source ( $V_{PL}$ ) and a subject. b) Thevenin equivalent circuit of the power line-subject capacitive coupling. c) Circuit model showing the coupling between a common mode voltage source, the electrodes system and the sEMG amplifier.  $Z_{e1}$ ,  $Z_{r1}$  and  $Z_{r2}$  are the impedances, considered purely resistive in the sEMG band, of the exploring, monopolar reference and ground reference electrodes respectively.

$A_d$  is the total amplification of the bio-potential amplifier and CMRR is its Common Mode Rejection Ratio.

It is possible to observe that  $V_{ORPL}$  can be reduced by (1) attenuating the common mode input voltage  $V_C$ ; (2) using a biopotential amplifier with adequate CMRR and a high input impedance and (3) controlling the impedance unbalance between the monopolar reference and the exploring electrodes ( $Z_{e1} - Z_{r1}$ ).

The reduction of the common mode input voltage  $V_C$  can be achieved lowering the  $Z_{r2}$  impedance or the value of the stray capacitance  $C_p$  (e.g. using a battery powered acquisition system). The first can result be achieved by increasing the size of the reference electrode but this solution is limited by geometrical factors related to the encumbrance of the reference electrode. On the other hand, the value of the  $C_p$  capacitance is difficult to control and depends on the environmental conditions where the signal acquisition is carried out (e.g. the distance between the amplifier and the power line source).

The following section describes the experimental setup used to demonstrate that controlling the impedance unbalance between the monopolar reference and the exploring electrodes and choosing a high CMRR instrumentation amplifier could greatly reduce the power line interference, resulting in an improvement of the signal quality for HD-sEMG recordings.

### B. Experimental Setup Description

The experimental setup was designed to measure the input-referred power line interference for different configurations of the reference electrodes.

The following three different electrode configurations were considered:

- Standard Ag/AgCl electrodes (Kendall Arbo, 24 mm diameter) used either for monopolar and ground references and for sEMG detection (Setup 1);
- Ag/AgCl electrodes (Kendall Arbo, 24 mm diameter) used for monopolar and ground references and a 5 mm

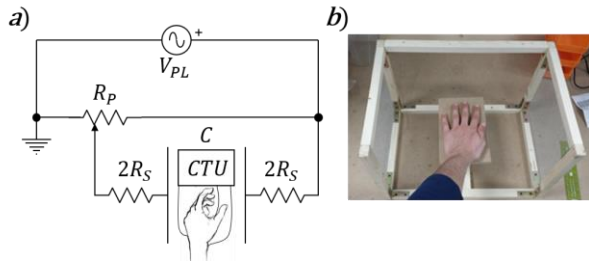

Figure 3. Electric field generator used to measure the power line interference in different configurations of the reference electrodes. a) Block diagram of the electric field generator. Two couple of 8.2 M $\Omega$  resistors ( $2R_S$ ) were connected in series to the capacitor C in order to limit the current flowing into the circuit. The  $R_P$  (1 M $\Omega$ ) potentiometer was used to adjust the electric field inside the capacitor (having a capacitance of 1.6 pF). b) The capacitor C, built with metallic meshes and a wooden structure, is depicted.

diameter Ag exploring electrode used for the detection of HD-sEMG [18] (Setup 2);

- The previous configuration was repeated matching the impedance unbalance between the monopolar and the detection electrodes by means of a potentiometer placed in series with the monopolar reference as described in the following (Setup 3).

Monopolar sEMG signals were collected from the Abductor Pollicis Brevis muscle of a healthy subject (Male, Age 26) and the monopolar and ground reference electrodes were placed on the wrist condyles.

The study was performed following the principles outlined in the Helsinki Declaration of 1975, as revised in 2000. Informed consent was obtained from the subject after providing detailed explanation of the study procedures.

In order to guarantee the repeatability of the measurements and compare the results obtained using different electrode configurations, a 50 Hz adjustable electric field generator was built (Fig. 3).

Fig. 3a shows the block diagram of the electric field generator connected to a 220 V<sub>RMS</sub> power line source ( $V_{PL}$ ). The amplifier and the subject's hand with the sEMG electrodes were placed into the constant electric field generated inside the capacitor C. Such capacitor was built using two parallel metal meshes and a wood structure (Fig. 3b). The measured capacitance C was 1.6 pF. Two 8.2 M $\Omega$  resistors ( $R_S$ ) were connected in series to the capacitor C in order to limit the current flowing into the circuit in the unwanted case the subject touches the capacitor parallel plates. The  $R_P$  (1 M $\Omega$ ) potentiometer was used to adjust the electric field inside the capacitor. For each electrode configuration, the input-referred power line interference was measured for three different electric field intensities of 74 V/m, 300 V/m, and 500 V/m respectively.

Signals have been detected using a classic three-electrode sEMG amplifier developed at LISiN, having the INA333 (Texas Instruments, USA) instrumentation amplifier as a front-end, a passband filter between 10 Hz and 500 Hz and a total in-band gain of 60 dB. The acquisition circuit has a 100 dB CMRR and approximately 1 G $\Omega$  input impedance at 50Hz.

TABLE I. MEASURED ELECTRODE-SKIN IMPEDANCES (50Hz)

	$ Z_{e1} $ (k $\Omega$ )	$ Z_{r1} $ (k $\Omega$ )	$ \Delta Z $ (k $\Omega$ )
Setup 1	11.9	14.9	3.0
Setup 2	157.6	14.9	142.7
Setup 3 (after matching)	157.6	149.8	7.8

The circuit was battery powered and a  $\pm 9$  V dual power supply was fed using a DC/DC Converter (Traco Power, Baar, Switzerland).

Signals were acquired using a PC-powered, floating, digital oscilloscope (Pico Scope 2300, Cambridge, UK).

For each experimental condition, the electrode-skin impedance of each electrode was measured in order to estimate the  $|Z_{e1} - Z_{r1}|$  unbalance.

The impedance measurements were carried out by using an impedance meter, designed at LISiN. This instrument injects current through the impedance under estimation and measures the resulting voltage ( $V_V$ ). A sinusoidal input voltage signal  $V_I$ , provided by an internal oscillator with adjustable frequency and amplitude, is converted into a proportional current.  $V_I$  and the voltage drop across the impedance  $V_V$  are simultaneously acquired using a NI-DAQ USB-6210 acquisition board (National Instruments, Texas, USA) with 16-bit resolution and a sampling frequency of 10 kHz.

The impedance amplitude at a given frequency is calculated by the ratio  $V_V/V_I$ . All the measurements were carried out at 50 Hz.

### III. RESULTS AND DISCUSSION

Table I shows the measured electrode-skin impedances at 50 Hz ( $|Z_{e1}|$  and  $|Z_{r1}|$ ) for three different electrode configurations.

Fig. 4 shows the measured input-referred power line interference for the three electrode configurations described above and three electric field intensities.

It is possible to observe that matching the impedance unbalance between the monopolar reference and the exploring

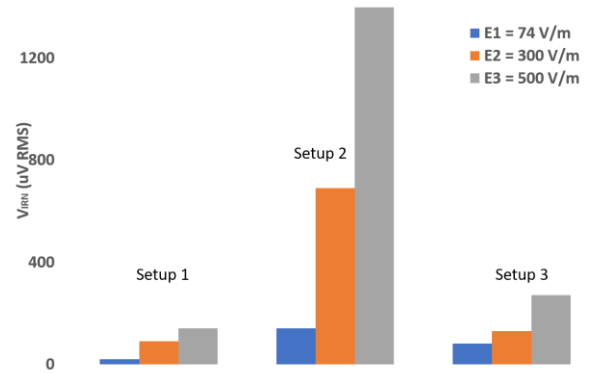

Figure 4. Measured input-referred power line interference ( $\mu$ V<sub>RMS</sub>) for three electrode configurations and electric field intensities of 74 V/m, 300 V/m and 500 V/m respectively. When the input impedances were matched (Setup 3) the power line interference results similar to the one obtained when three big electrodes are used for the monopolar sEMG acquisition (Setup 1).

electrodes (Setup 3) greatly reduces, as expected, the input-referred power line interference. The residual power line interference can be explained by the non-zero common mode voltage at the input of the system and the non-infinite CMRR of the sEMG amplifier.

This result is consistent among different amplitudes of the input-referred common mode voltage as demonstrated by varying the electric field potential in which the subject and the detection systems are immersed.

It is important to note that the electrode configuration of the Setup 1 is not feasible in the case of HD-sEMG detection because of the size of the exploring electrodes. Consequently, a monopolar bio-signal amplifier able to match the impedance unbalance between the monopolar reference and the exploring electrodes would increase the amplifier immunity to 50 Hz interference due to the capacitive coupling between the subject and the power line source.

Fig. 5 shows a preliminary block diagram of such amplifier integrating an impedance meter and an impedance matching circuit. The design and implementation of such amplifier will be the subject of future work. It is evident that this type of amplifier, needs the integration of an impedance meter and an impedance matching circuit, resulting more cumbersome and expensive than a classical bio-signal amplifier for sEMG detection. Nevertheless, the cost or the encumbrance of additional circuitry can be compensated in the case of HD-sEMG acquisitions, where tens or hundreds of channels are required. In this case, these factors would become negligible with respect to the number of components needed to design and implement hundreds of sEMG amplifiers.

#### IV. CONCLUSIONS

This paper provided a common mode analysis of the detection system used to collect monopolar sEMG signals. Different configuration of the reference electrodes leading to different behaviors in terms of immunity to the power line interference have been experimentally characterized. Results showed that a monopolar HD-sEMG amplifier having the possibility to actively match the input impedance unbalance between active and reference electrodes would be indicated to reduce the problem of power line interference. A new impedance-controlled HD-sEMG signal amplifier has been proposed and discussed.

#### ACKNOWLEDGMENT

Authors wish to thank Davide Mastrapasqua for the assistance in the experimental setup preparation.

#### REFERENCES

- [1] A. Holobar, D. Farina, M. Gazzoni, R. Merletti, and D. Zazula, "Estimating motor unit discharge patterns from high-density surface electromyogram," *Clin. Neurophysiol.*, 2009.
- [2] M. J. Zwarts and D. F. Stegeman, "Multichannel surface EMG: basic aspects and clinical utility.," *Muscle Nerve*, vol. 28, no. 1, pp. 1–17, 2003.
- [3] G. Drost, D. F. Stegeman, B. G. M. van Engelen, and M. J. Zwarts, "Clinical applications of high-density surface EMG: A systematic review," *J. Electromyogr. Kinesiol.*, vol. 16, no. 6, pp. 586–602, 2006.
- [4] R. Merletti, A. Botter, A. Troiano, E. Merlo, and M. A. Minetto, "Technology and instrumentation for detection and conditioning of the surface electromyographic signal: State of the art," *Clinical*

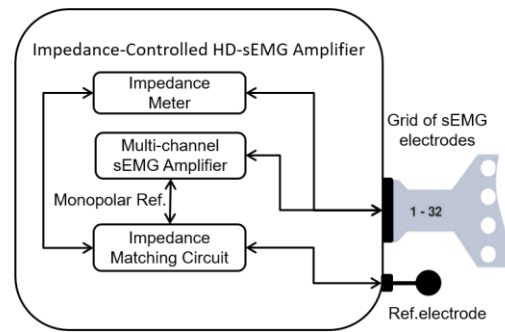

Figure 4. Block diagram of the proposed impedance-controlled HD-sEMG amplifier. A number of sEMG amplifiers allow the detection and conditioning of sEMG signals collected by means of grids or arrays of electrodes. The impedance meter measures the electrode-skin impedance unbalance between the exploring and the monopolar reference electrode and drives an impedance matching circuit forcing the monopolar reference electrode to have an impedance similar to that of the exploring electrodes, thus reducing the power line interference due to the electrode impedance unbalance.

- [5] H. J. Hermens, B. Freriks, C. Disselhorst-Klug, and G. Rau, "Development of recommendations for SEMG sensors and sensor placement procedures," *J. Electromyogr. Kinesiol.*, 2000.
- [6] B. B. Winter and J. G. Webster, "Reduction of Interference Due to Common Mode Voltage in Biopotential Amplifiers," *IEEE Trans. Biomed. Eng.*, 1983.
- [7] A. Botter and T. M. Vieira, "Filtered virtual reference: A new method for the reduction of power line interference with minimal distortion of monopolar surface EMG," *IEEE Trans. Biomed. Eng.*, 2015.
- [8] D. T. Mewett, K. J. Reynolds, and H. Nazeran, "Reducing power line interference in digitised electromyogram recordings by spectrum interpolation," *Med. Biol. Eng. Comput.*, 2004.
- [9] M. Haberman, A. Cassino, and E. Spinelli, "Estimation of stray coupling capacitances in biopotential measurements," *Med. Biol. Eng. Comput.*, 2011.
- [10] C. Aliau-Bonet and R. Pallas-Areny, "A novel method to estimate body capacitance to ground at mid frequencies," *IEEE Trans. Instrum. Meas.*, 2013.
- [11] R. Pallas-Areny and J. Colominas, "Simple, fast method for patient body capacitance and power-line electric interference measurement," *Med. Biol. Eng. Comput.*, vol. 29, no. 5, pp. 561–563, 1991.
- [12] M. F. Chimeno and R. Pallàs-Areny, "A comprehensive model for power line interference in biopotential measurements," *IEEE Trans. Instrum. Meas.*, 2000.
- [13] A. C. Metting van Rijn, A. Peper, and C. A. Grimbergen, "High-quality recording of bioelectric events - Part 1 Interference reduction, theory and practice," *Medical & Biological Engineering & Computing*, 1990.
- [14] J. C. Huhta and J. G. Webster, "60-Hz Interference in Electrocardiography," *IEEE Trans. Biomed. Eng.*, 1973.
- [15] J. G. Webster, "Reducing motion artifacts and interference in biopotential recording.," *IEEE Trans. Biomed. Eng.*, vol. 31, no. 12, pp. 823–826, 1984.
- [16] P. Cattarello and R. Merletti, "Characterization of dry and wet Electrode-Skin interfaces on different skin treatments for HDsEMG," in *2016 IEEE International Symposium on Medical Measurements and Applications, MeMeA 2016 - Proceedings*, 2016.
- [17] G. Piervigili, F. Petracca, and R. Merletti, "A new method to assess skin treatments for lowering the impedance and noise of individual gelled Ag-AgCl electrodes," *Physiol. Meas.*, 2014.
- [18] R. Merletti, D. Farina, and M. Gazzoni, "The linear electrode array: A useful tool with many applications," *J. Electromyogr. Kinesiol.*, vol. 13, no. 1, pp. 37–47, 2003.